

Assembly Instructions

Caution: You must read this before you process

Please look underneath Table top for hardware packs

TABLE

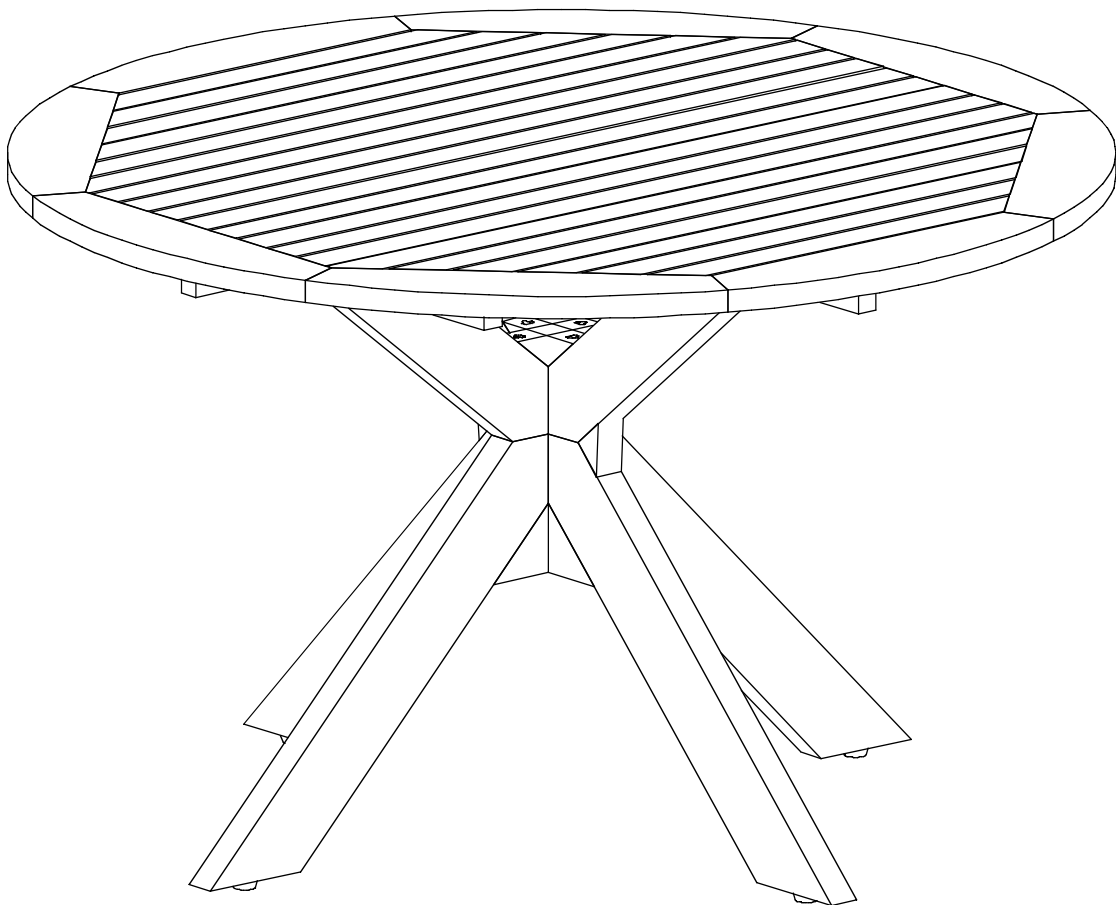

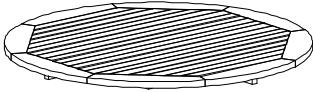
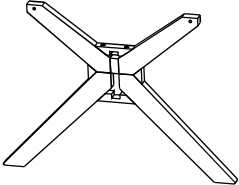
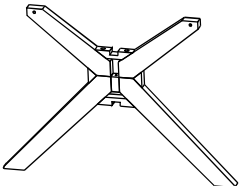

CAUTION : This Table is NOT a TOY.
Keep your child / children at bay during the assembly process.
When moving the Table and to prevent any possible damage, two adults are needed to execute this action.

Parts List

Label	Picture	Description	QTY
A		Table Top	1
B		First Leg Frame (with Leveler)	1
C		Second Leg Frame (with Leveler)	1

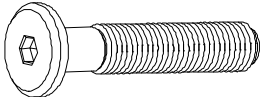
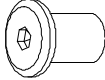
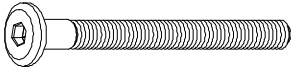
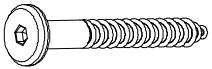
Hardware

Label	Picture	Description	QTY
①		Short Bolts (M8x55mm)	5
②		Sleeve Nut (M8x20mm)	5
③		Long Bolts (M6x90mm)	2
④		Screw (M7x45mm)	9
⑤		Allen key	2
⑥		Iron washer	5

Assembly Preparation

Before Beginning Assembly:

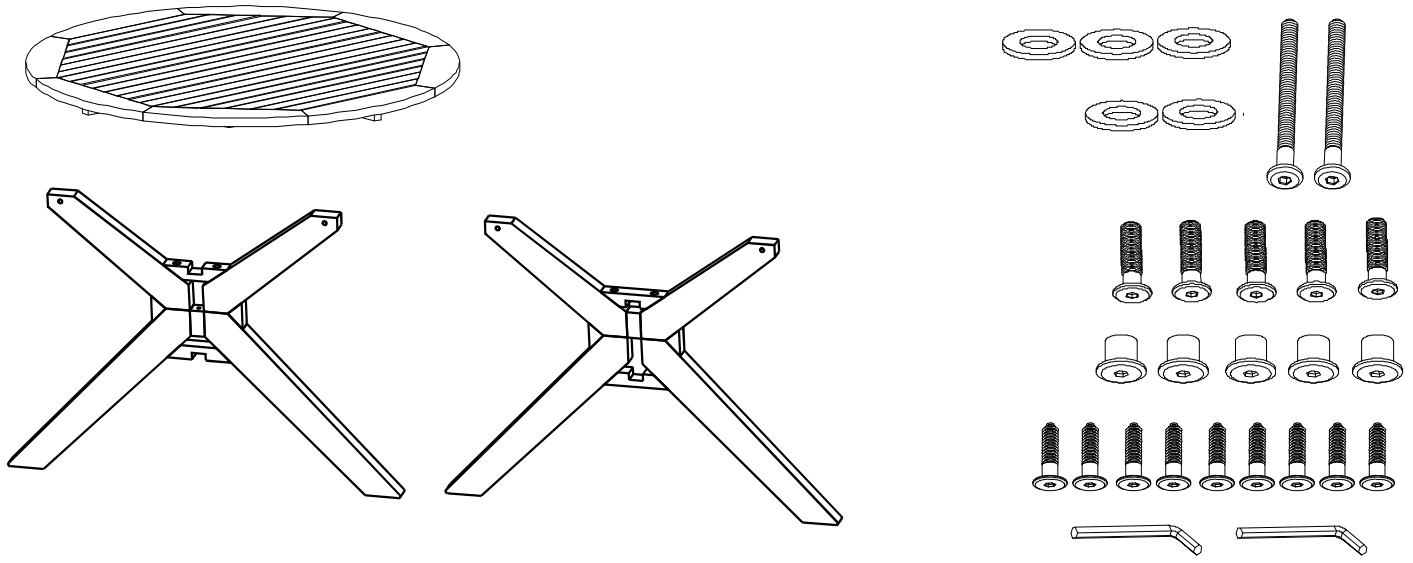

- Read instructions, cover to cover-



- Have 2 adults on hand for assembly-



- Do not assemble on flooring or carpet-



- Assemble on a clean non-marring surface (packing foam)-



- Save all packaging until finished-

Assembly Steps

Overview

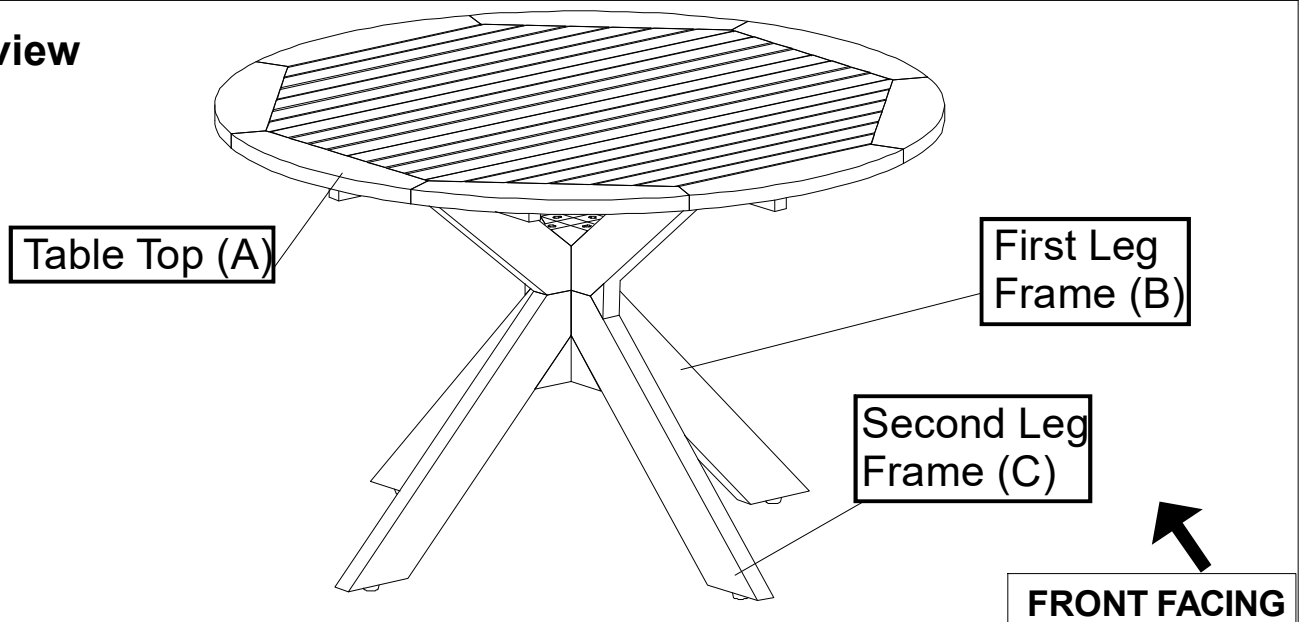

This Table has multiple parts and may require up to 30 minutes to assemble. To give you an overview, the above picture is provided to help you put the various parts into perspective. Please read through the instructions below to familiarise yourself with the parts and steps before assembly.

Step 1

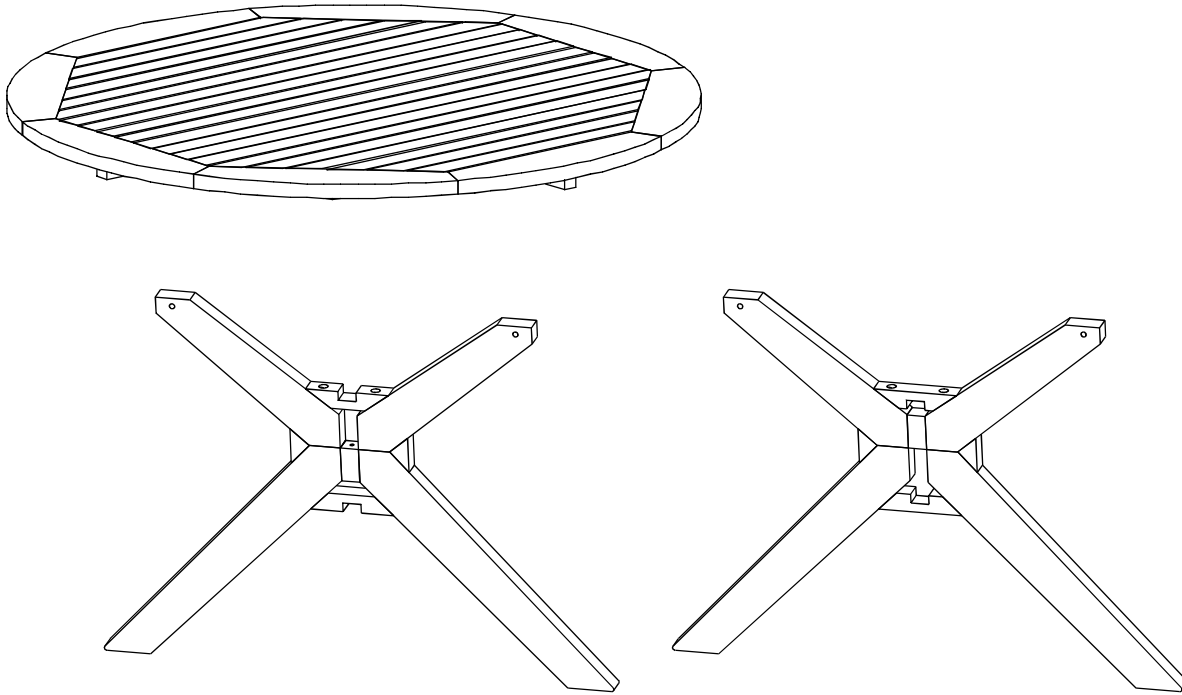

Unpack and place all parts on a clean, non-marring surface.

Step 2

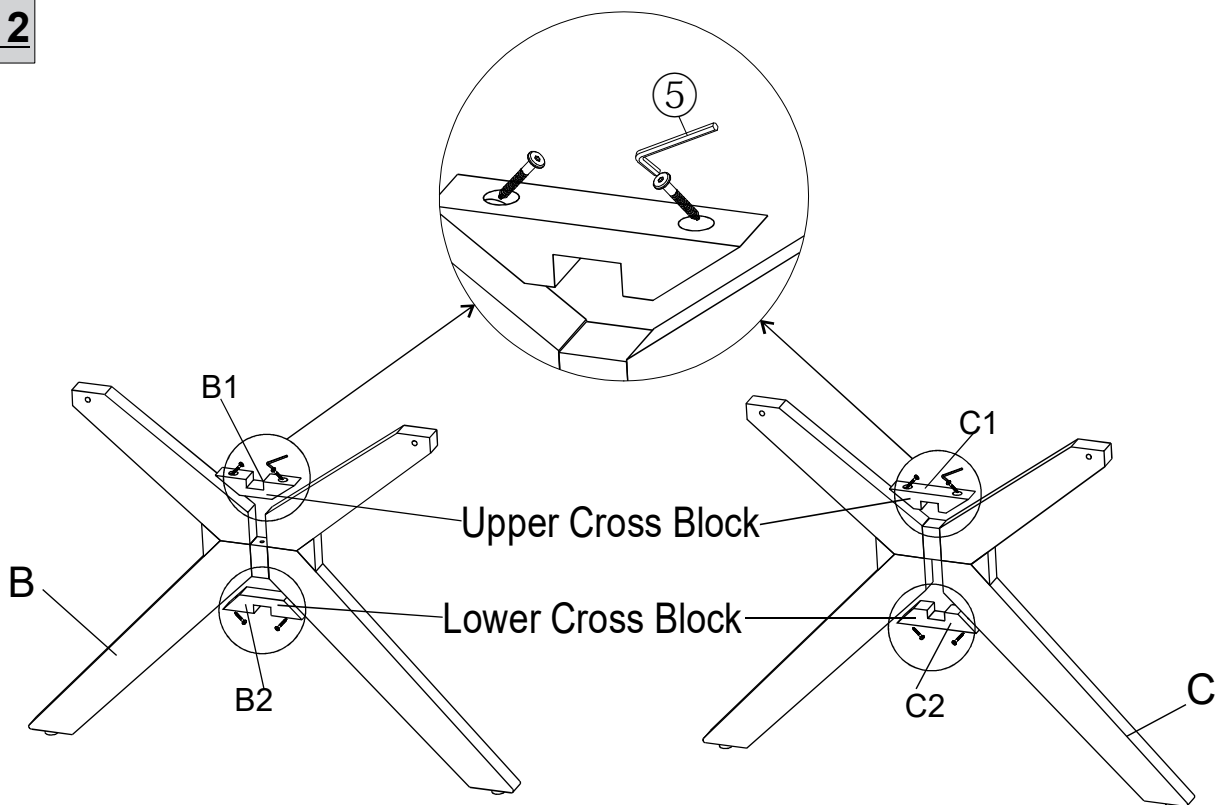

Use the Allen key (⑤) to unscrew the 8 Screws, the 2 Upper Cross Blocks (B1, C1) and the 2 Lower Cross Blocks (B2, C2) on the 2 Leg Frames (B,C). Then, **put the screws in the trash** and continue to step 3
Note: The Upper Cross Blocks and Lower Cross Blocks are labelled B1, C1, B2, C2 for easy recognition. Please note to use them correctly in the next steps.

Step 3

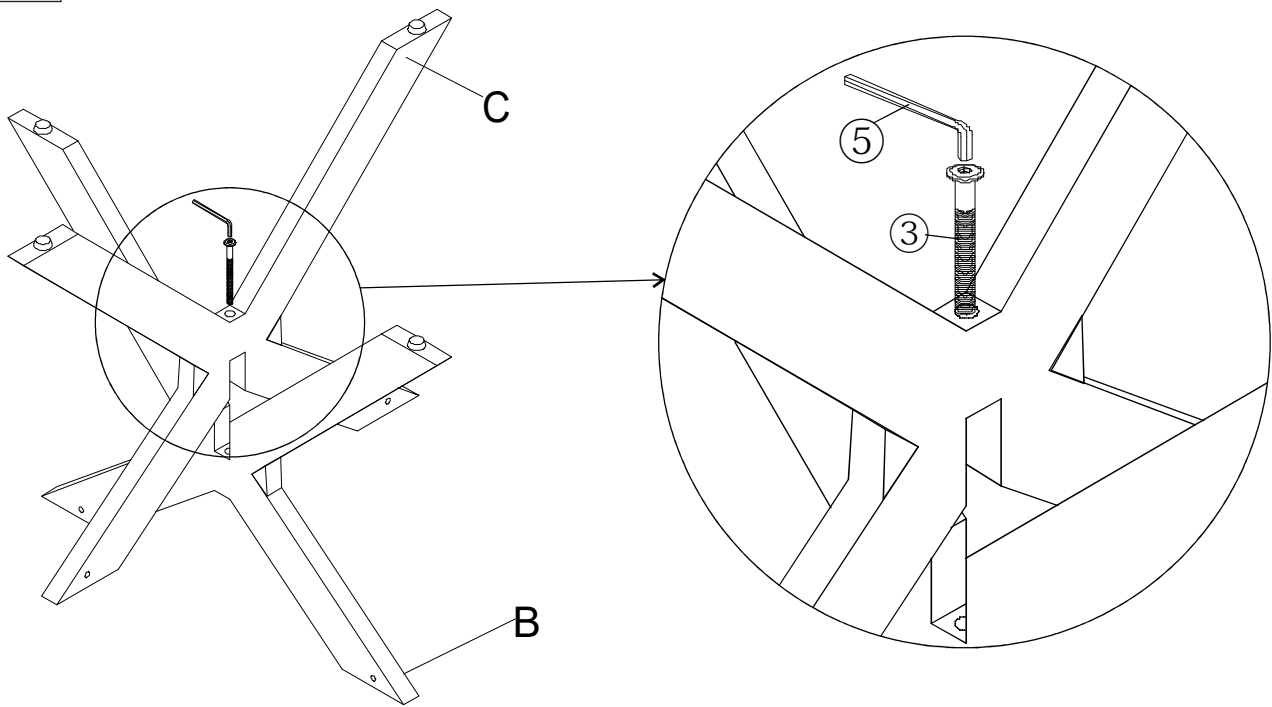

With the assistance of your partner, position the First Leg Frame (B) to the Second Leg Frame (C) as shown in the above picture.

Secure the First Leg Frame (B) to the Second Leg Frame (C) by using a Long Bolt (③) and the Allen Key (⑤).

**Note: In this step, the legs with the levelers will be upside down
Do not fully tighten the Bolts at this time.**

Step 4

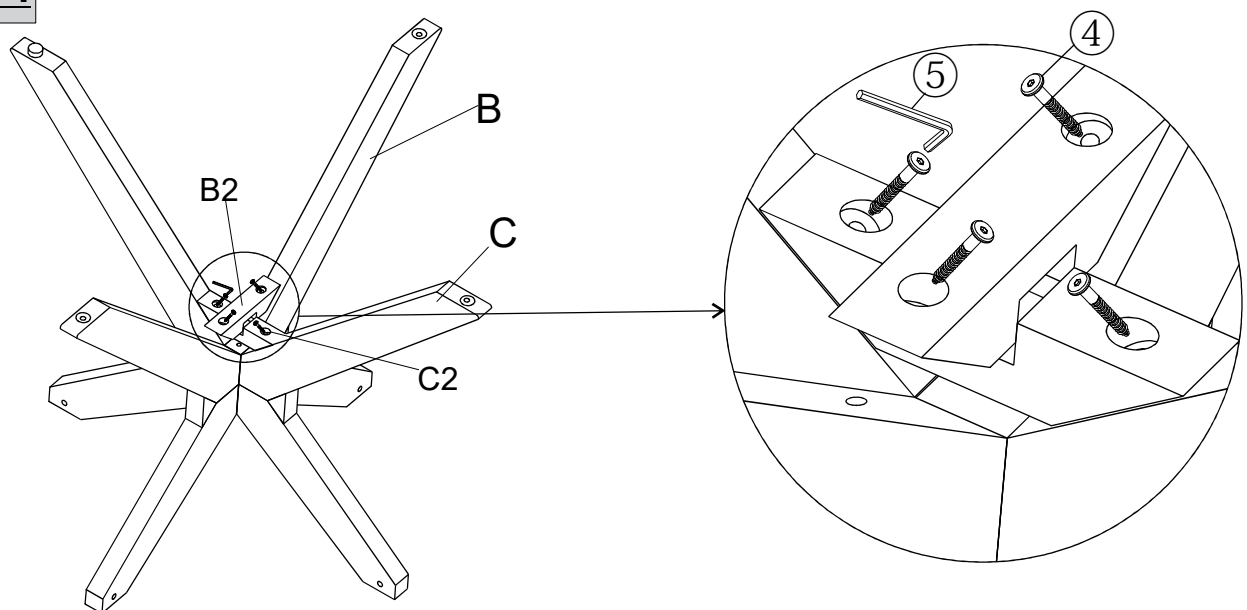

Use Screws (④) and the Allen key (⑤) to attach the Lower Cross Blocks (B2, C2) in step 2 onto the Leg Frames in step 3 as shown in the above picture.

Do not fully tighten the Screws at this time.

Step 5

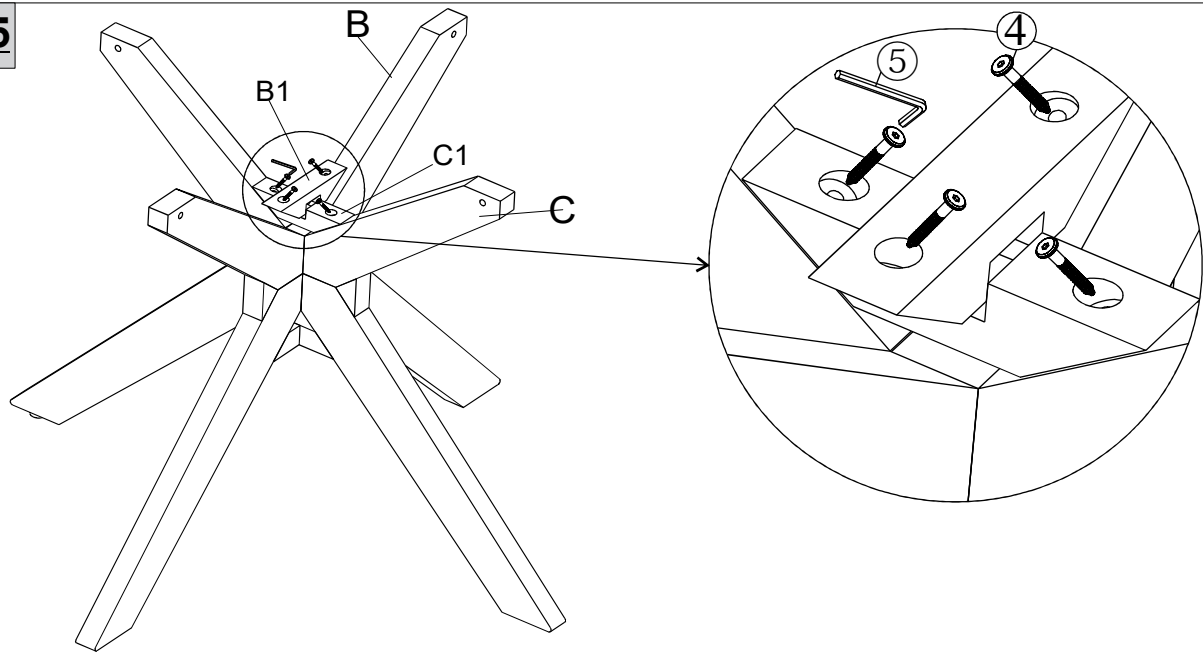

With the assistance of your adult partner, turn the assemble in step 4 180 degrees.

Repeat the same process from step 4 to secure the Upper Cross Blocks (B1, C1) from step 2 with the Leg Frames (B,C)

Do not fully tighten the Screws at this time.

Step 6

STEP 6.1

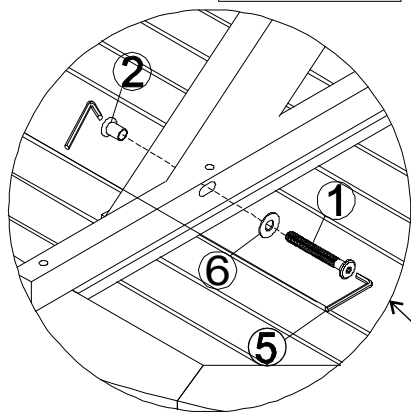

STEP 6.2

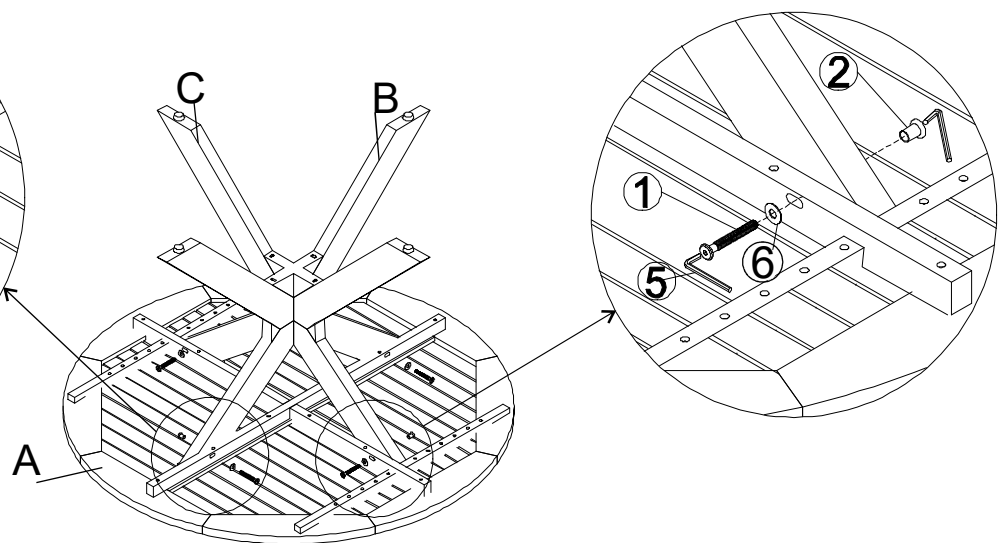

Place the Table top (A) with its underside skywards onto a clean, soft surface to avoid any scratches or possible damage to the product.

Position the assemble from step 5 onto the Table Top (A)

6.1) Using 2 Short Bolts (①), 2 Sleeve Nuts (②), 2 Iron Washers (⑥) and the Allen Key (⑤) connect the middle support bar of the Table Top (A) and the Leg Frame (B & C).

6.2) Using 2 Short Bolts(①), 2 Sleeve Nuts (②), 2 Iron Washers (⑥) and the Allen Key (⑤) connect the side support bar of the Table Top(A) and the Leg Frame (B & C).

Note: In this step, the legs with levelers will be upside down





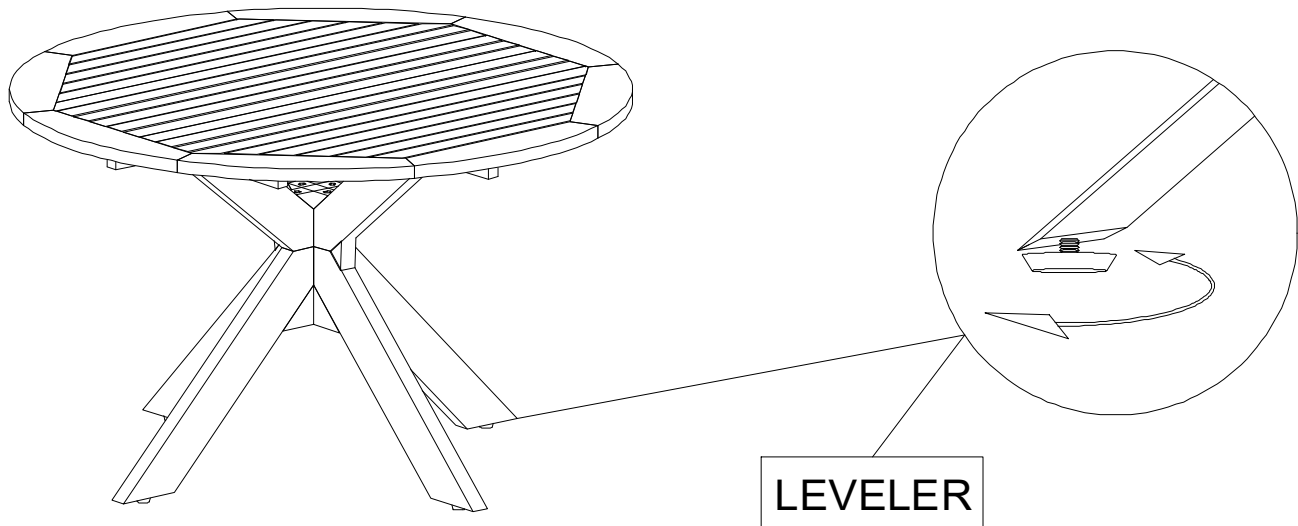



Do not fully tighten the Bolts at this time.

Step 7



With assistance from your adult partner, turn the Table back to its normal upright position.
EXERT pressure, floorwards, onto the Table.
This pressure will help the Legs and Table Top reach alignment at all joints.
Check for wobbles.
In a sequential manner, gradually tighten all Screws and Bolts until evenly secured.
Inspect the Table and make sure all parts are adequately connected.
Your Table is ready for use.
This Table can only be used on a flat, level surface.

Care & Maintenance

-  ● Do not put hot items directly on furniture surface
-  ● Do not clean furniture with harsh cleansers or polish.
-  ● To obtain the longest lifespan of your outdoor products, minimizing exposure to direct sunlight is recommended.
-  ● Children should not climb or jump on the furniture.
-  ● Do not write on furniture without a padded barrier to protect the surface.
-  ● To obtain the longest lifespan of your outdoor products , avoid extended and lengthy exposure to rain, snow, and direct sunshine. Whenever possible cover the product and /or place under patio or awnings.
-  ● Not for commercial use. For residential use only .
-  ● Stains may be removed with mild soap solution and damp cloth.

-  ● Dust and pick-up spills using a clean, non-colored, lint-free cloth .