

Pure & Easy



# **ASSEMBLY INSTRUCTIONS**

FTPLSS-4152 FTPLSS-0150  
FTPLSS-4153 FTPLSS-0151

TZAB-V1

# NOTICE

IMPORTANT, RETAIN FOR FUTURE REFERENCE: READ CAREFULLY  
WICHTIG, FÜR SPÄTERE NACHSCHLAGE AUFBEWAHREN: SORGFÄLTIG LESEN  
IMPORTANTE, GUARDAR PARA REFERENCIA FUTURA: LEER ATENTAMENTE  
IMPORTANTE, CONSERVARE PER RIFERIMENTI FUTURI: LEGGERE ATTENTAMENTE  
IMPORTANT, À CONSERVER POUR RÉFÉRENCE FUTURE : LIRE ATTENTIVEMENT

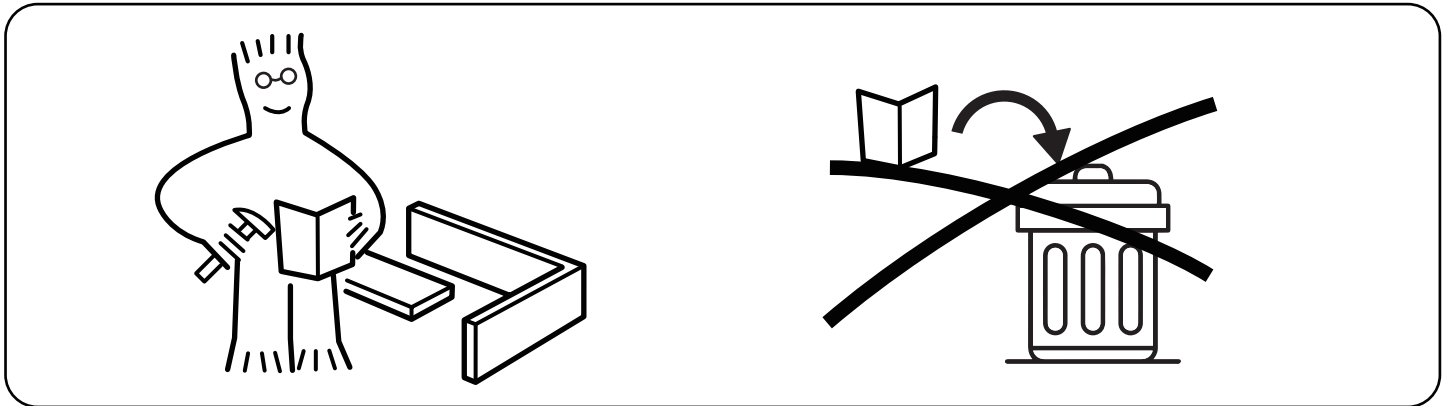

Assemble on a flat and solid surface. To avoid the unstable surface affecting the overall frame stability during installation.

Montieren Sie auf einer ebenen und festen Oberfläche. Um zu verhindern, dass eine unebene Oberfläche während der Montage die Gesamtrahmen-Stabilität beeinträchtigt.

Ensamblar en una superficie plana y sólida. Afin d'éviter que la surface inégale n'affecte la stabilité générale du cadre lors de l'installation.

Assemblare su una superficie piana e solida. Per evitare che una superficie irregolare influisca sulla stabilità complessiva della struttura durante l'installazione.

Assembler sur une surface plate et solide. Para evitar que la instalación en una superficie irregular afecte la estabilidad general del marco.

Professional installation is highly recommended.  
Eine professionelle Installation wird dringend empfohlen.  
Une installation professionnelle est fortement recommandée.  
Si raccomanda vivamente l'installazione professionale.  
Se recomienda altamente la instalación profesional.



Periodically Check That All Components Are Tightly Secured.  
Überprüfen Sie Regelmäßig, Dass Alle Komponenten Fest Gesichert Sind.  
Vérifiez Périodiquement Que Tous Les Composants Sont Bien Fixés.  
Controllare Periodicamente Che Tutti I Componenti Siano Ben Fissati.  
Verifique Periódicamente Que Todos Los Componentes Estén Bien Asegurados.



It is recommended that multiple people assemble this product.  
Es wird empfohlen, dass mehrere Personen dieses Produkt zusammenbauen.  
Il est recommandé que plusieurs personnes assemblent ce produit.  
Si raccomanda che più persone assemblino questo prodotto.  
Se recomienda que varias personas ensambren este producto.

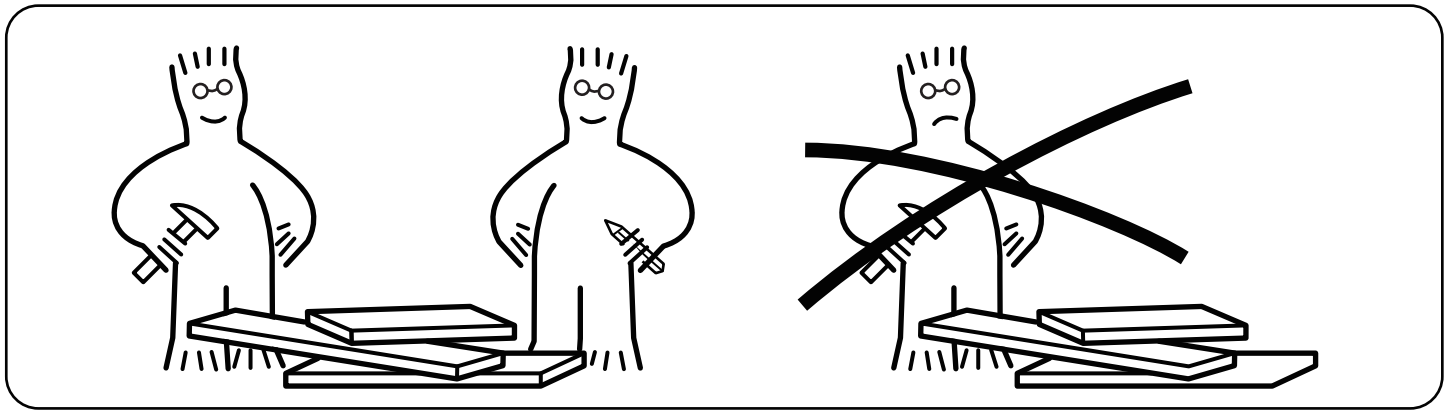







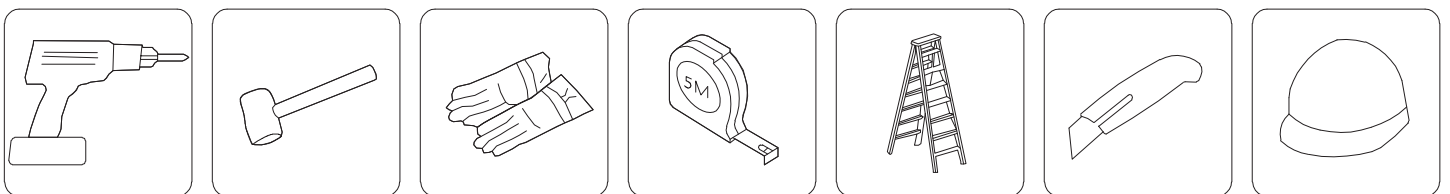









Please contact us if parts of your furniture are missing.  
Bitte kontaktieren Sie uns, wenn Teile Ihrer Möbel fehlen.  
Por favor contáctenos si faltan piezas de sus muebles.  
Si prega di contattarci se mancano parti dei vostri mobili.  
Veuillez nous contacter si des pièces de vos meubles manquent.

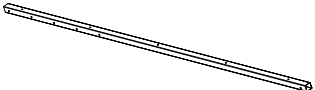

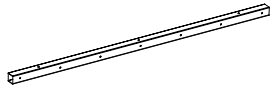

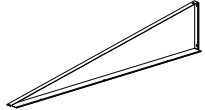
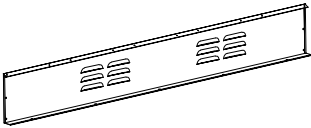
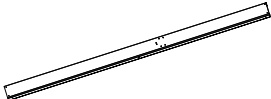

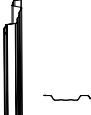

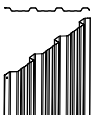

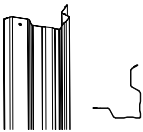
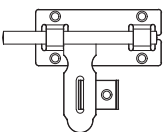
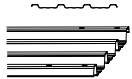
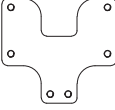

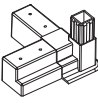

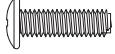
Please have the following auxiliary tools ready:  
Bitte halten Sie die folgenden Hilfswerkzeuge bereit:  
Veuillez préparer les outils auxiliaires suivants :  
Si prega di preparare i seguenti strumenti ausiliari:  
Por favor, tenga listos los siguientes herramientas auxiliares:

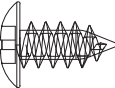
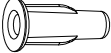

# PARTS

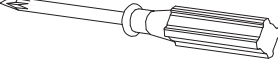
Item no. Nr. N° d'article Articolo No. Artículo No.	Reference Image Referenzbild Image de référence Immagine di riferimento Imagen de referencia	Qty. Menge Qté. Qtà Cant.	Item no. Nr. N° d'article Articolo No. Artículo No.	Reference Image Referenzbild Image de référence Immagine di riferimento Imagen de referencia	Qty. Menge Qté. Qtà Cant.
1		X1	17L		X1
2		X2	17R		X1
3		X1	19		X2
5		X4	20		X2
6		X1	21		X2
7		X2	21L		X1
8		X1	21R		X1
9		X1	22		X1
15		X2	W1		X2
16		X1	W3		X9

Item no. Nr. N° d'article Articolo No. Artículo No.	Reference Image Referenzbild Image de référence Immagine di riferimento Imagen de referencia	Qty. Menge Qté. Qtà Cant.	Item no. Nr. N° d'article Articolo No. Artículo No.	Reference Image Referenzbild Image de référence Immagine di riferimento Imagen de referencia	Qty. Menge Qté. Qtà Cant.
W7		X4	S2		X1
W12		X5	S3		X1
M1		X2	S4	 ST4X10mm	X159
C		X4	S6	 M4X8mm	X42
F		X4	S6A		X5
F4		X4	S7		X41
F7		X44	S8	 ST5X16mm	X4
F8		X34	S9		X4
F9		X2	S12		X1
S1		X1	S15		X1

# EXPLODED VIEW

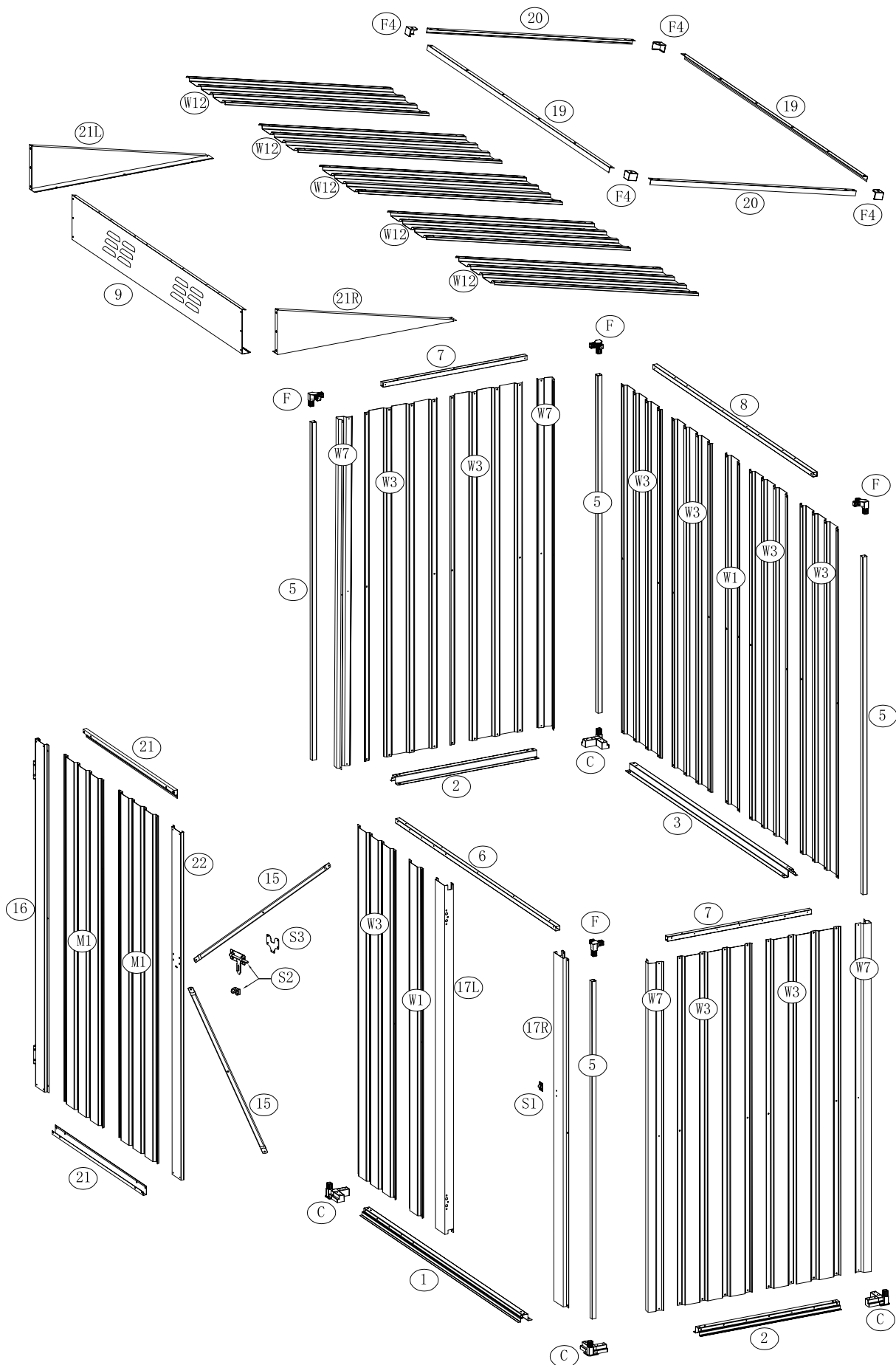

# ASSEMBLY

# 1



① 1pc



② 2pcs



③ 1pc



Ⓢ 4pcs



Ⓢ 4 16pcs

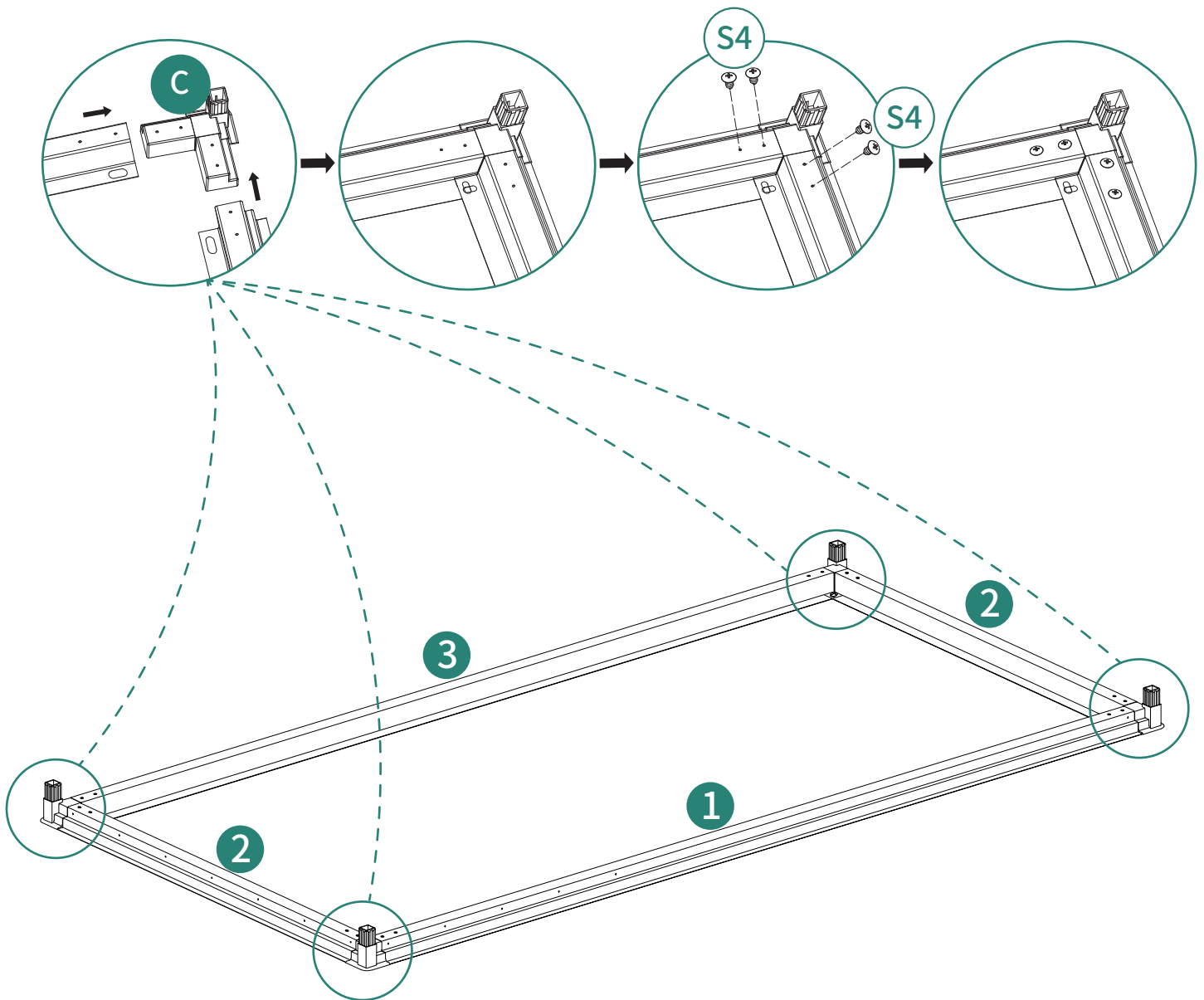

2

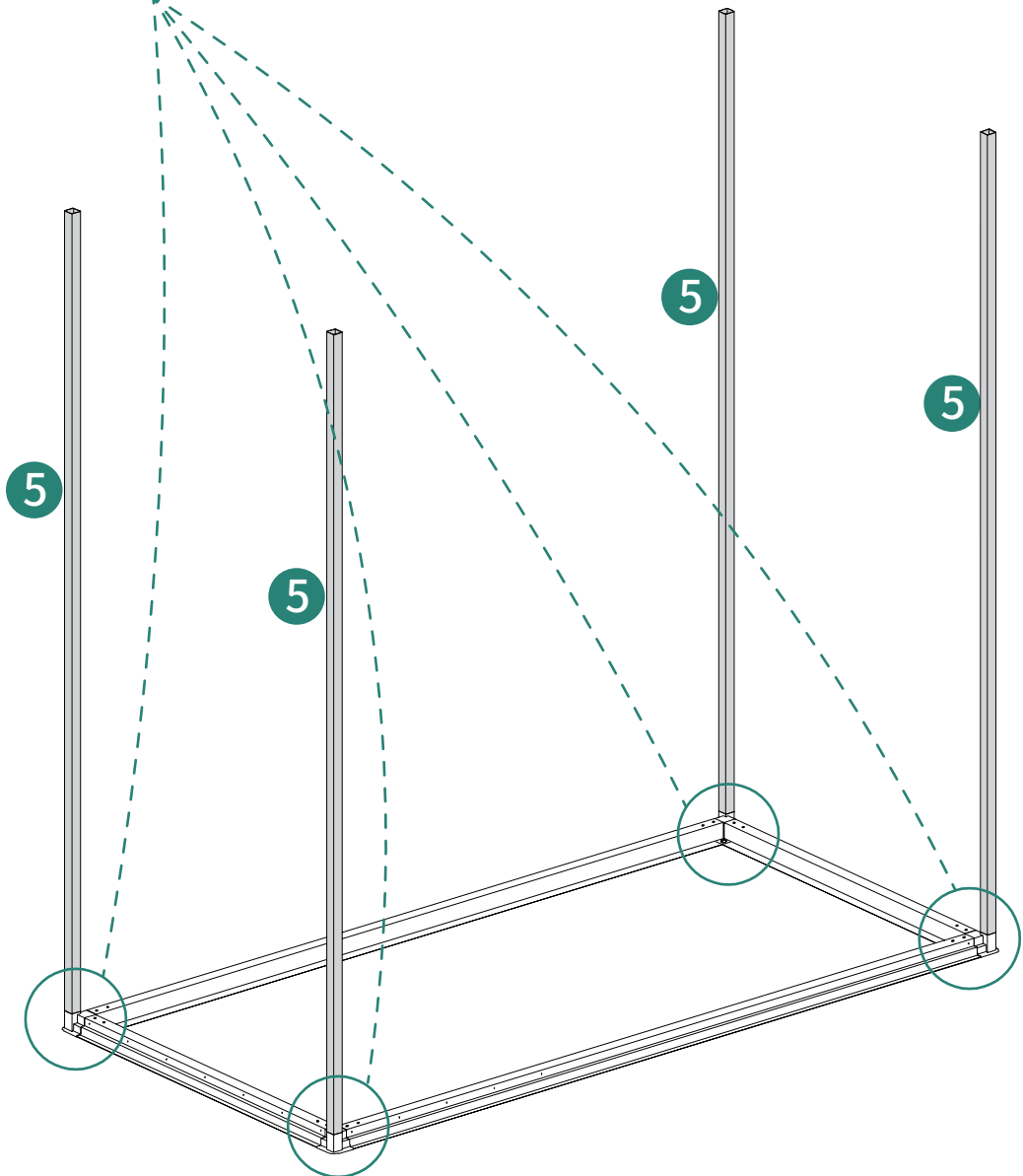
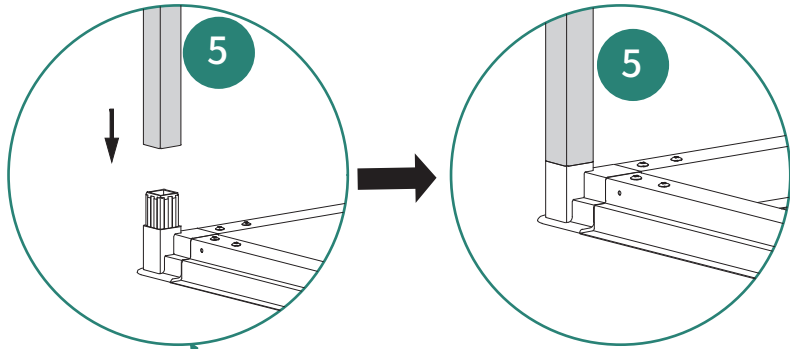
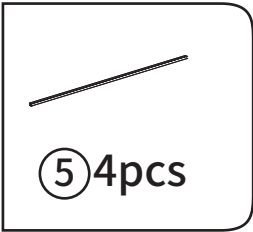

# 3



⑥ 1pc



⑦ 2pcs



⑧ 1pc



ⓕ 4pcs



Ⓢ4 8pcs

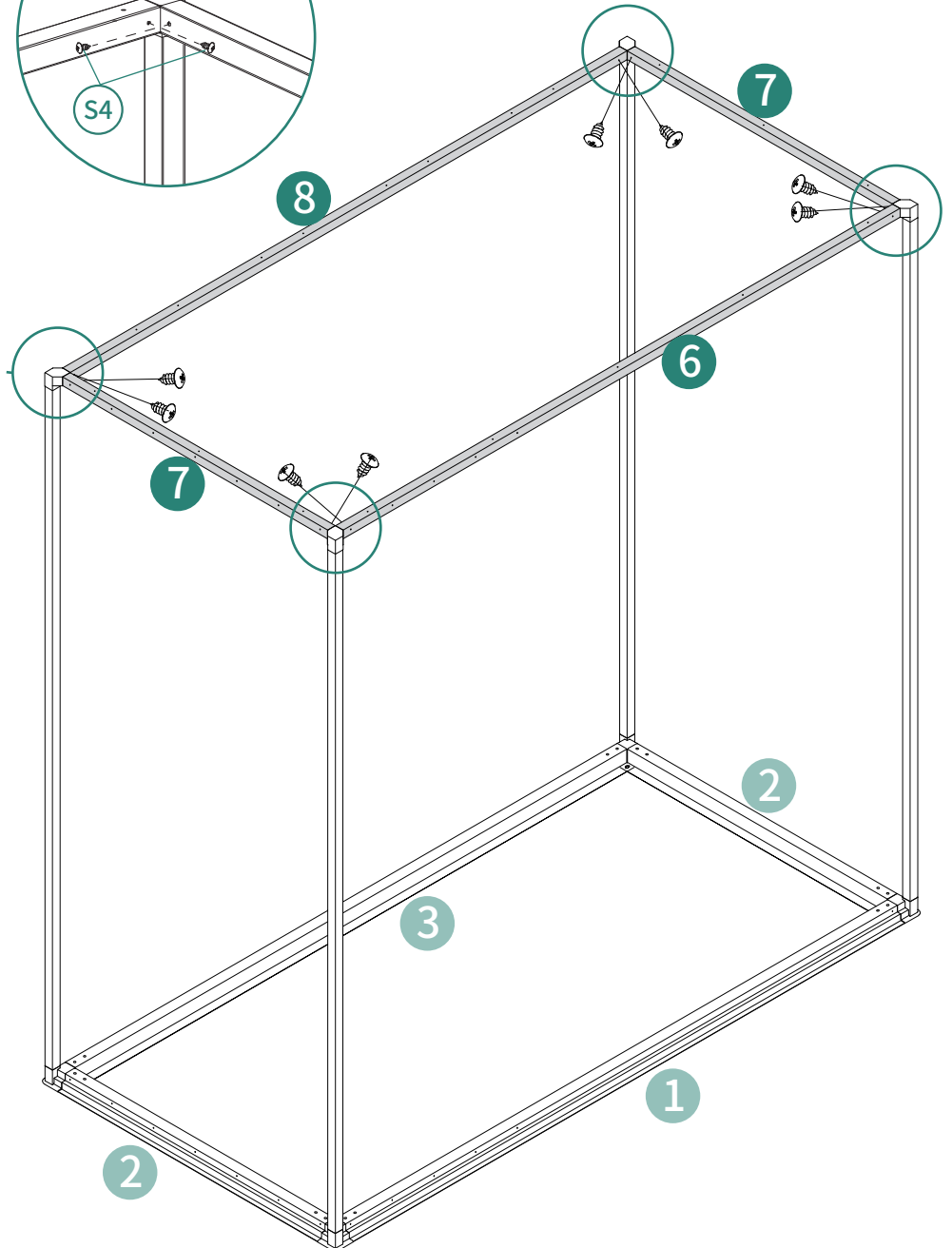
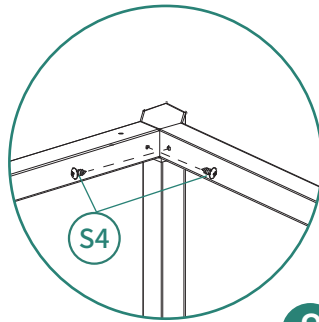
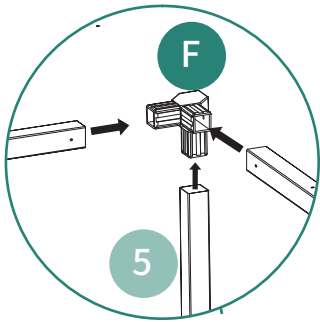

# 4



W3 4pcs



S4 20pcs



S6 2pcs



S7 2pcs

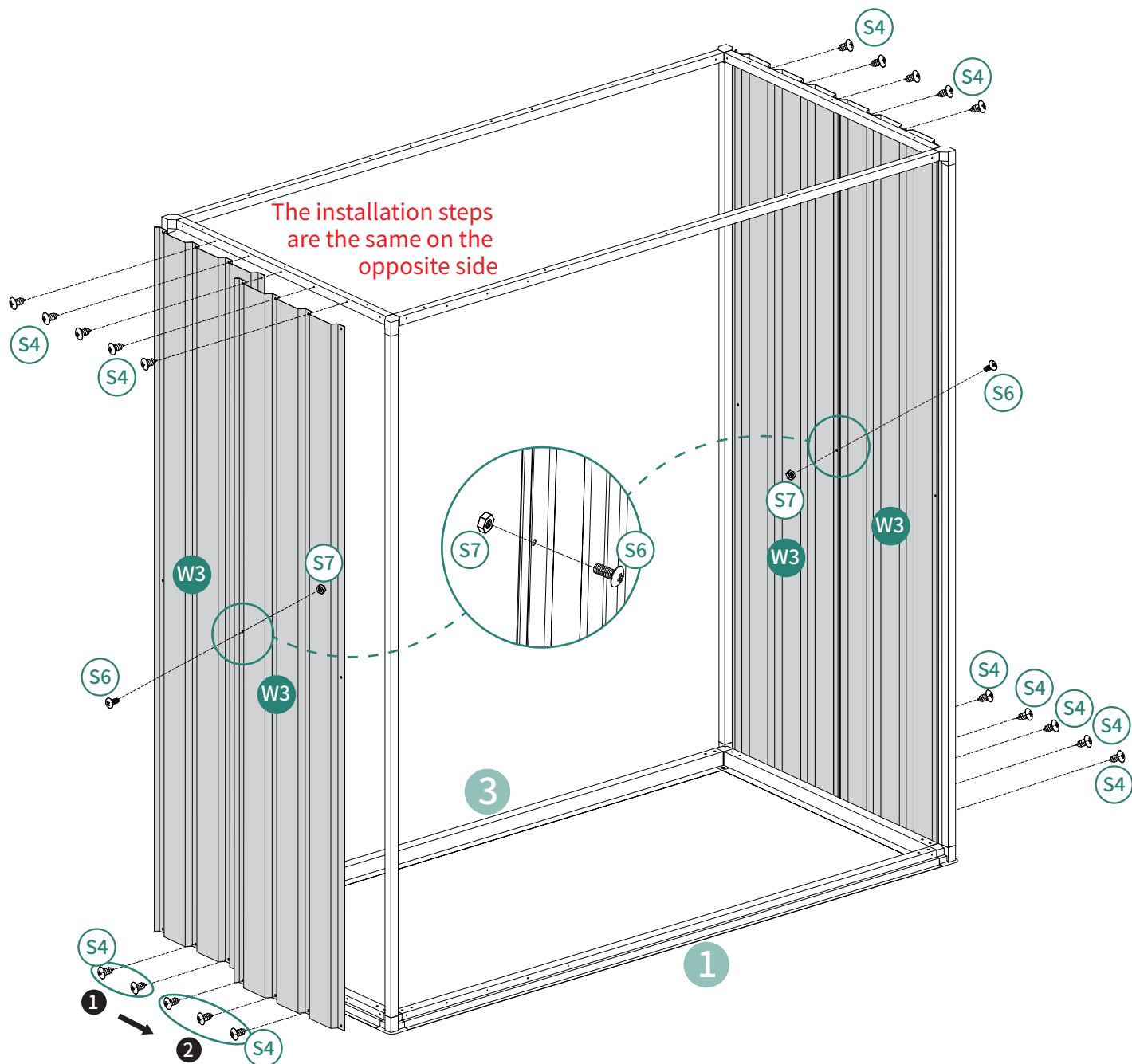

Fasten the screws according to the numerical order.  
Befestigen Sie die Schrauben der numerischen Reihenfolge nach.  
Serrez les vis selon l'ordre numérique.  
Fissa le viti secondo l'ordine numerico.  
Apriete los tornillos de acuerdo con el orden numérico.

# 5



W7 4pcs



S4 8pcs



S6 4pcs



S7 4pcs

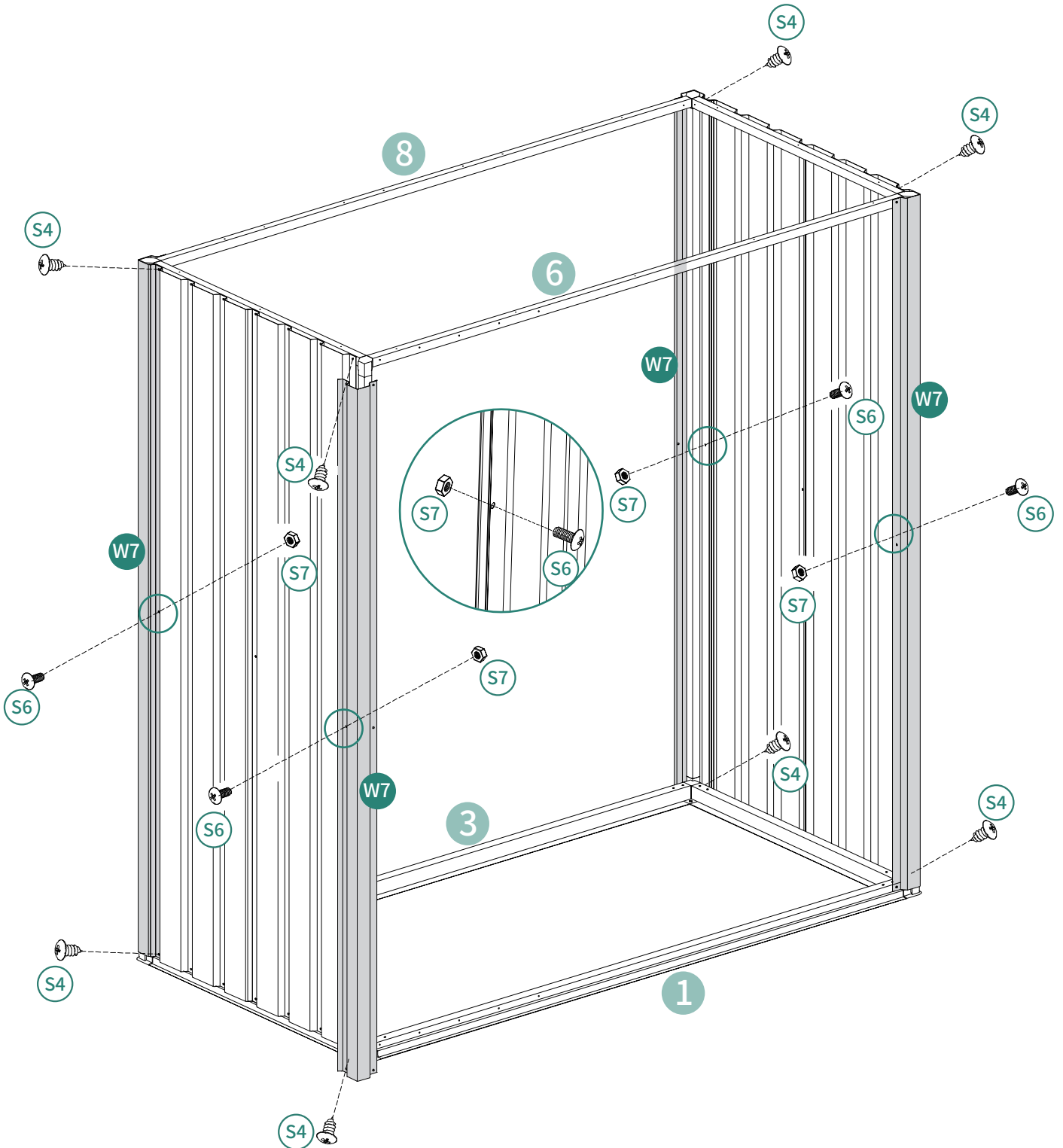

# 6



W1 1pc

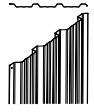

W3 4pcs



S4 28pcs



S6 6pcs



S7 6pcs

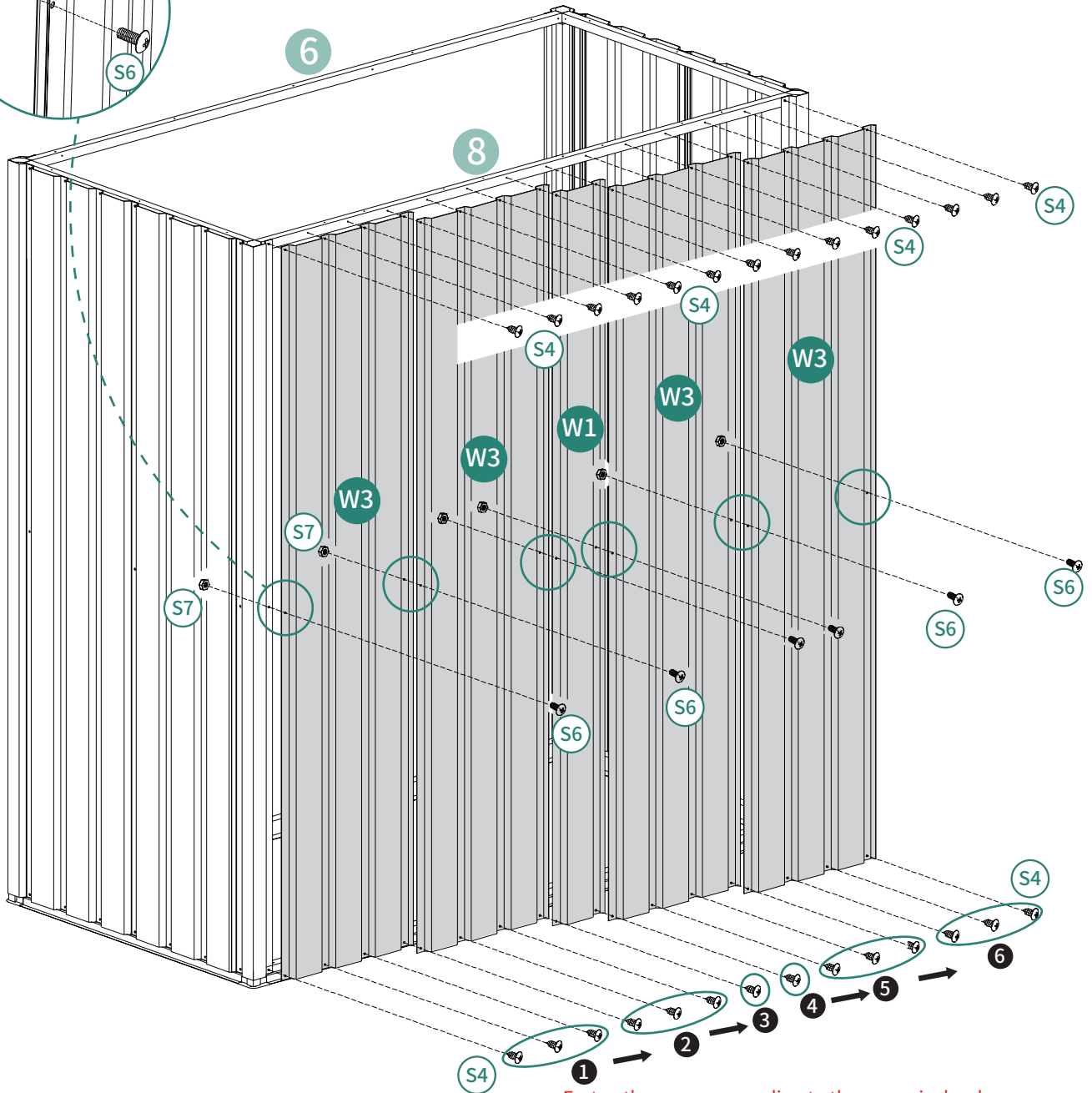
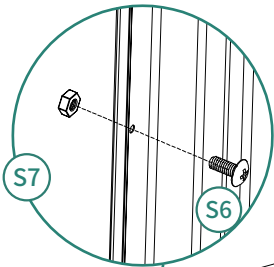

Fasten the screws according to the numerical order.  
Befestigen Sie die Schrauben der numerischen Reihenfolge nach.  
Serrez les vis selon l'ordre numérique.  
Fissa le viti secondo l'ordine numerico.  
Apriete los tornillos de acuerdo con el orden numerico.

7



W3 1pc



S4 6pcs



S6 1pc



S7 1pc

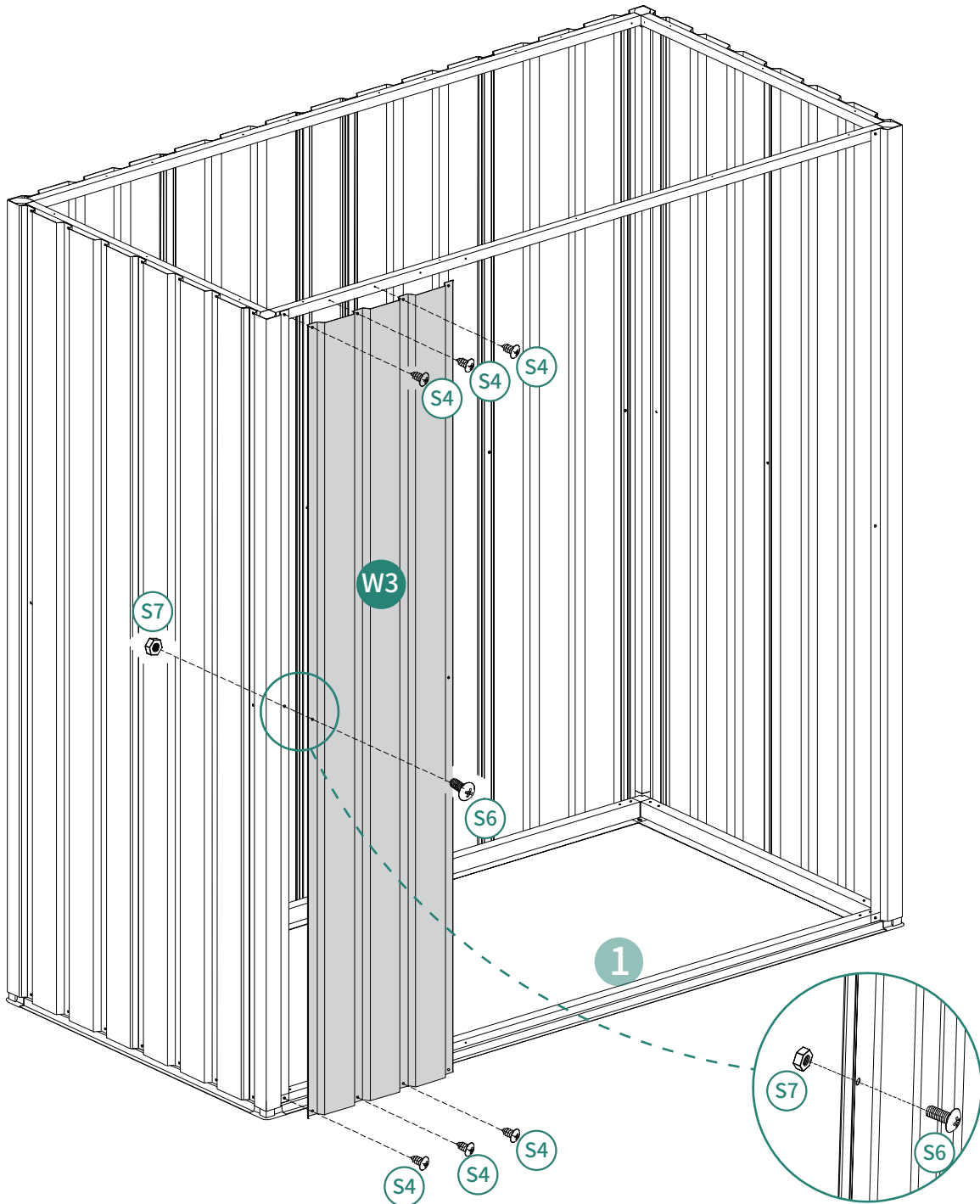

8

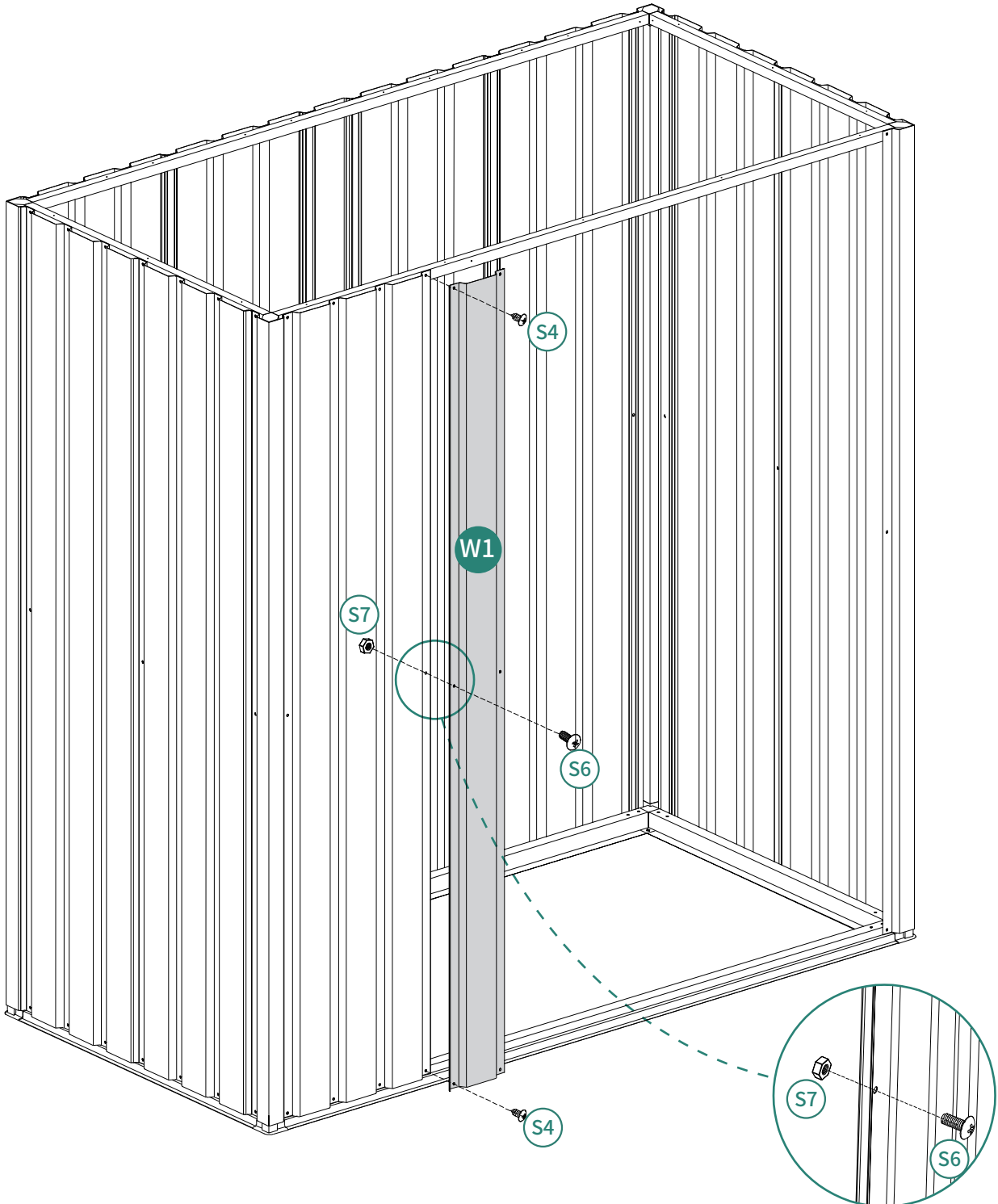

# 9



17L 1pc

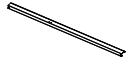

17R 1pc



S1 1pc



S4 8pcs





S6 4pcs

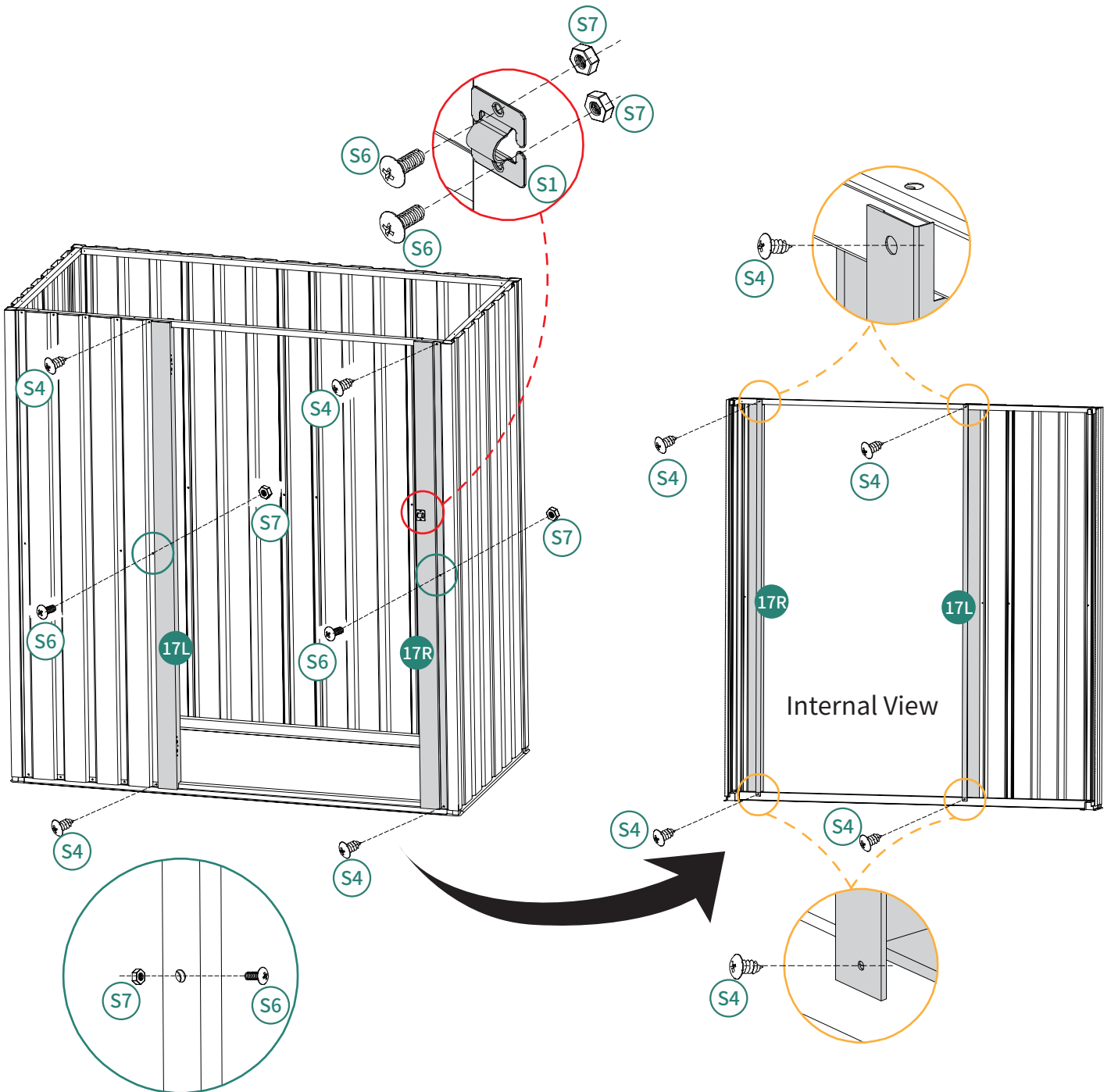

S7 4pcs



**10**

		
21L 1pc	21R 1pc	S4 6pcs

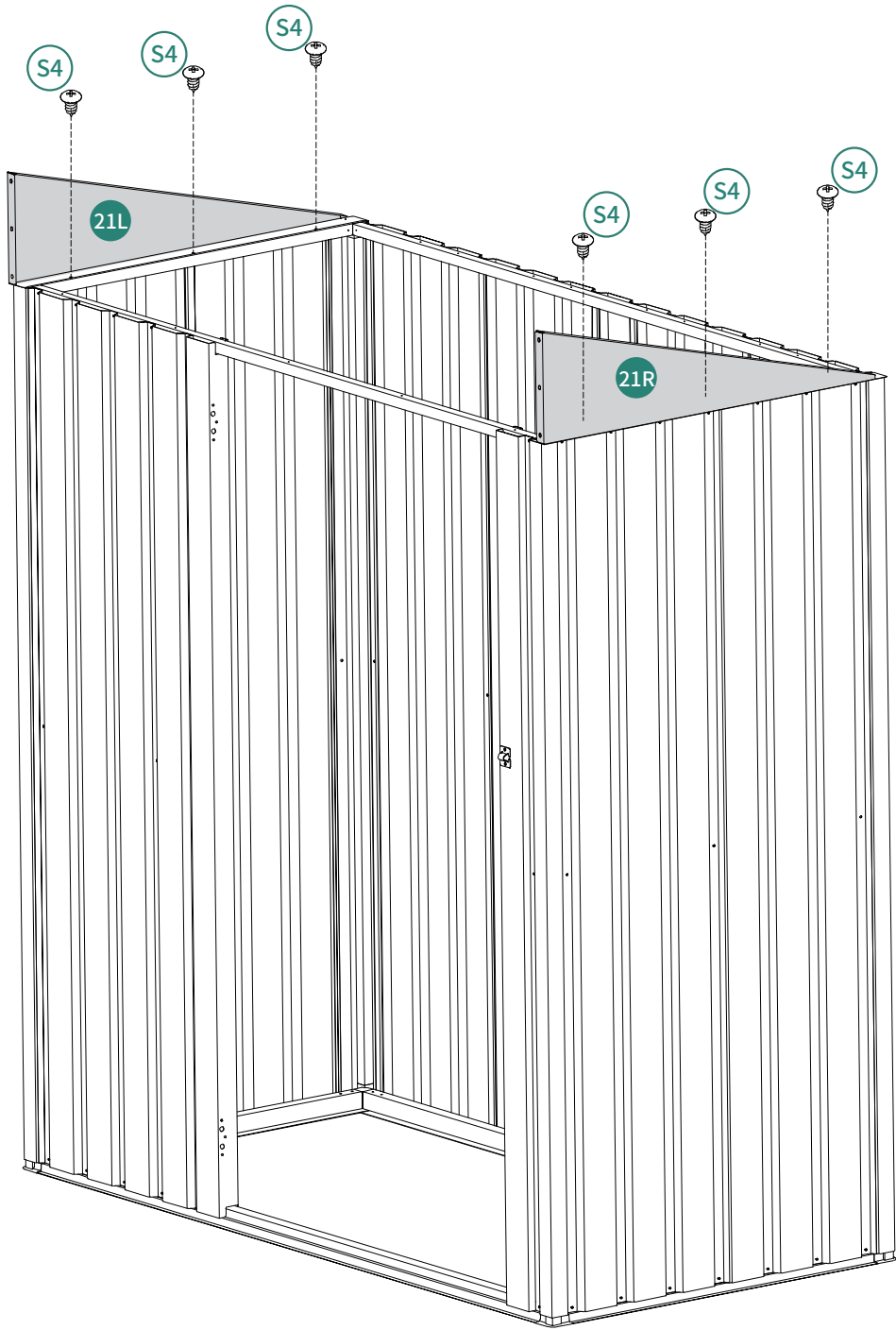

11



9 1pc



S4 5pcs



S6 6pcs



S7 6pcs

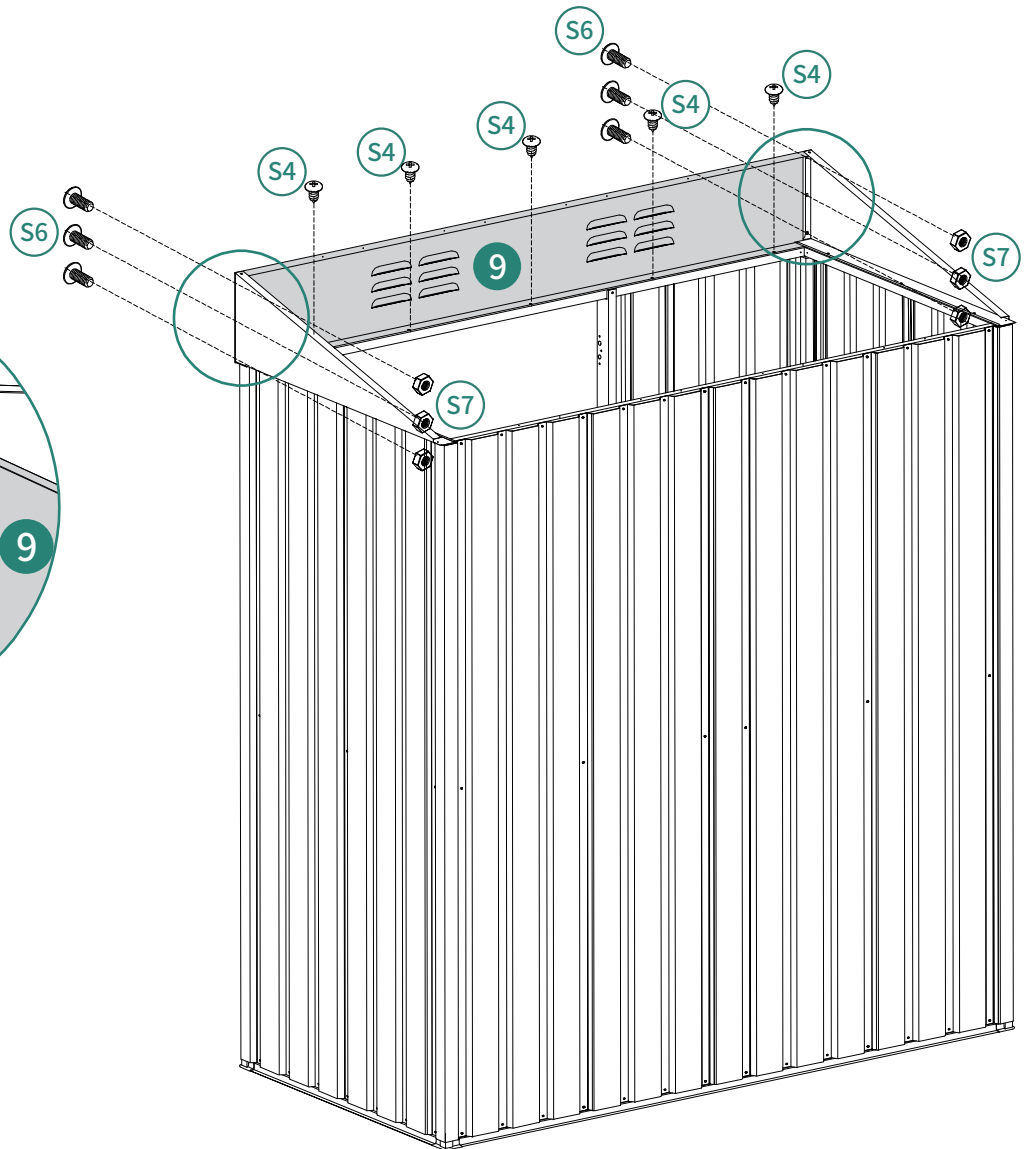
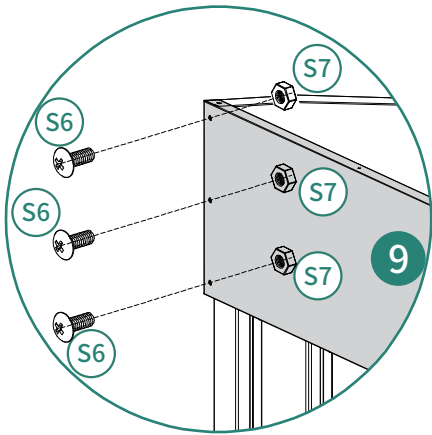

# 12

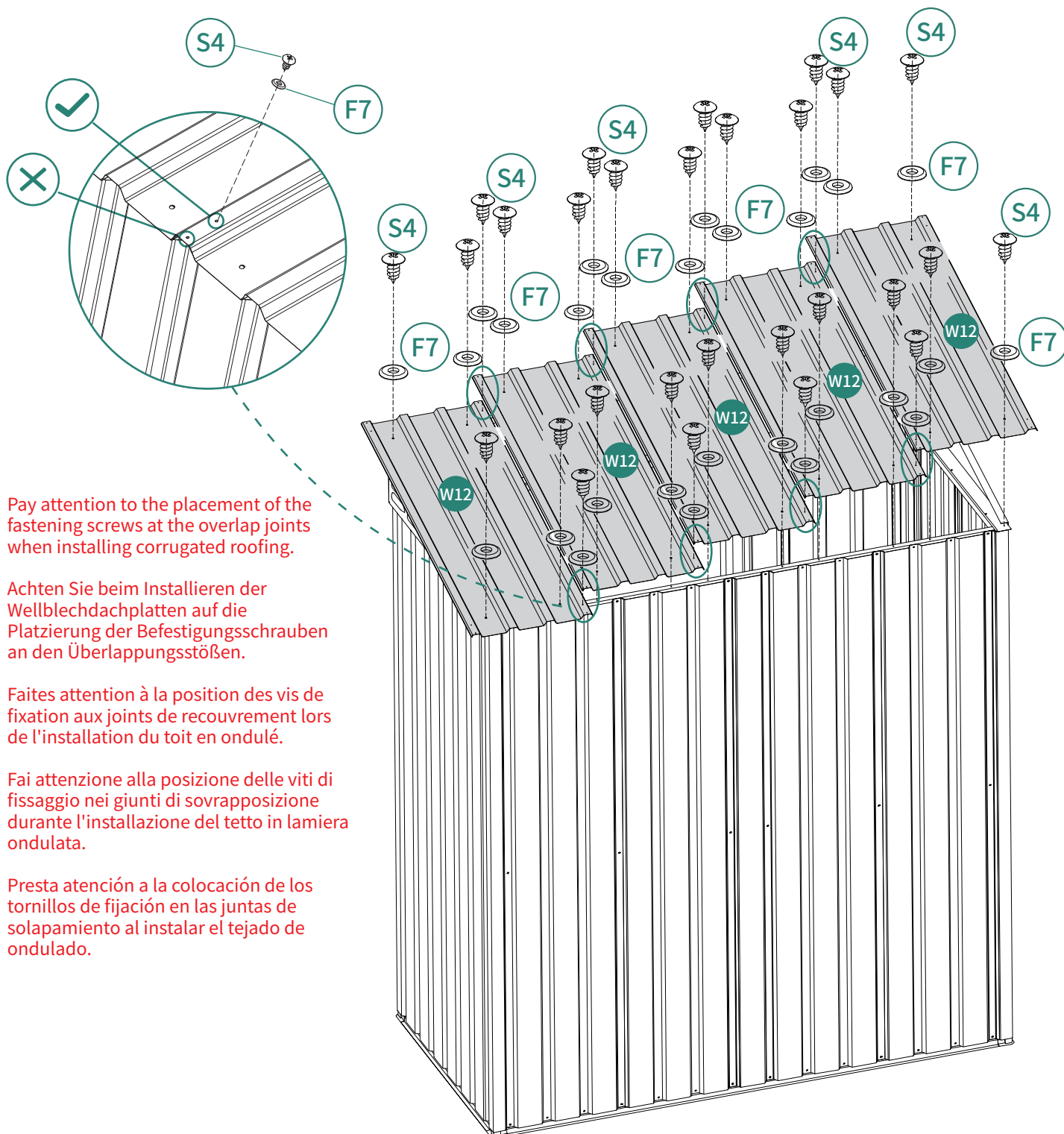

Pay attention to the placement of the fastening screws at the overlap joints when installing corrugated roofing.

Achten Sie beim Installieren der Wellblechdachplatten auf die Platzierung der Befestigungsschrauben an den Überlappungsstößen.

Faites attention à la position des vis de fixation aux joints de recouvrement lors de l'installation du toit en ondulé.

Fai attenzione alla posizione delle viti di fissaggio nei giunti di sovrapposizione durante l'installazione del tetto in lamiera ondulata.

Presta atención a la colocación de los tornillos de fijación en las juntas de solapamiento al instalar el tejado de ondulado.

# 13



20 2pcs



S4 4pcs



F7 4pcs

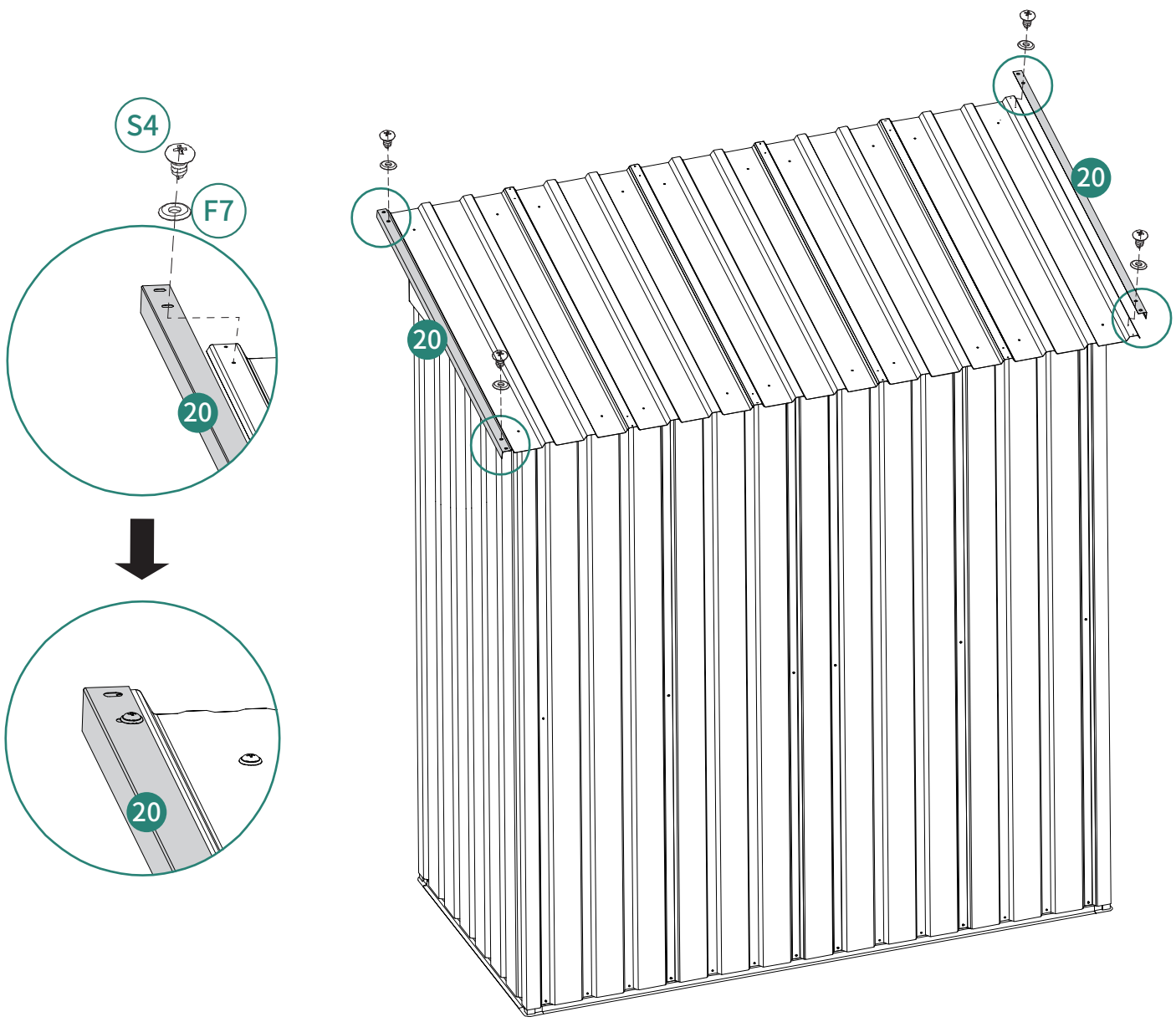

# 14



①9 2pcs



①4 8pcs



①8 4pcs



①4 4pcs



①7 12pcs

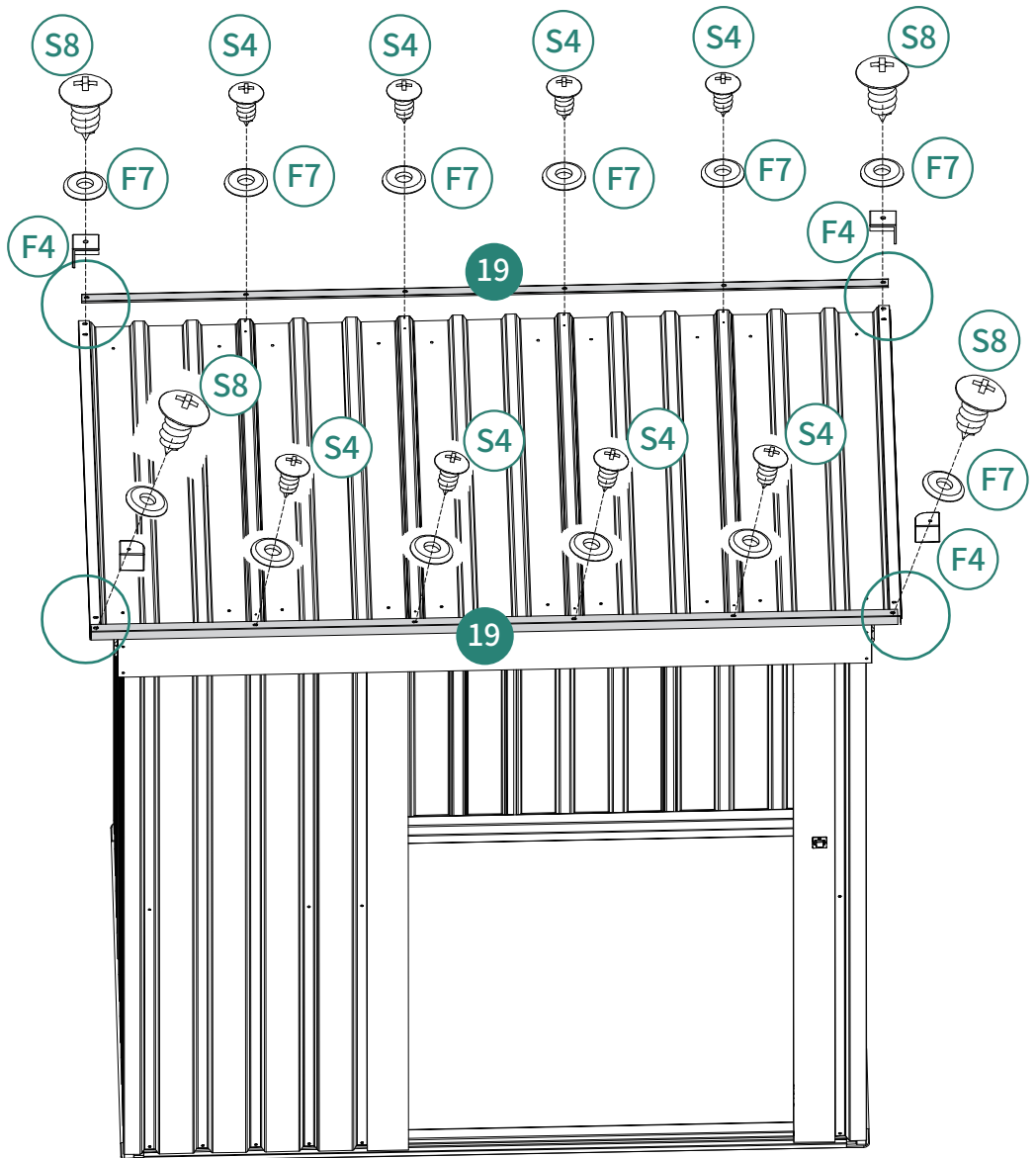
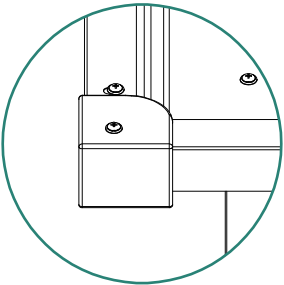
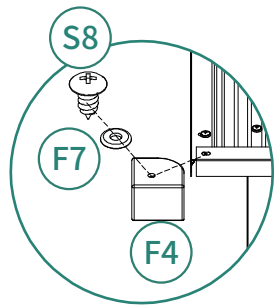

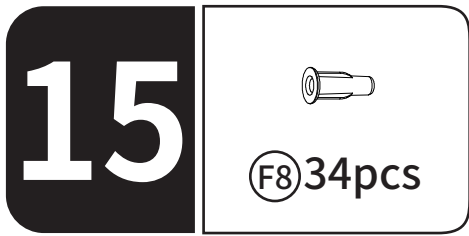

After fixing the screws, there will be some exposed screw parts on the component. Please use the provided plastic protective covers to protect the exposed screw parts, to avoid scratches during use.

Nachdem die Schrauben befestigt sind, werden einige Schraubenteile am Bauteil sichtbar sein. Bitte verwenden Sie die bereitgestellten Kunststoffschutzabdeckungen, um die freiliegenden Schraubenteile zu schützen und Kratzer während der Benutzung zu vermeiden.

Après avoir fixé les vis, certaines parties des vis seront exposées sur le composant. Veuillez utiliser les protections en plastique fournies pour protéger les parties exposées des vis, afin d'éviter les rayures pendant l'utilisation.

Dopo aver fissato le viti, ci saranno alcune parti delle viti esposte sul componente. Si prega di utilizzare le coperture protettive in plastica fornite per proteggere le parti esposte delle viti, per evitare graffi durante l'uso.

Después de fijar los tornillos, habrá algunas partes expuestas de los tornillos en el componente. Por favor, utilice las cubiertas protectoras de plástico proporcionadas para proteger las partes expuestas de los tornillos y evitar rasguños durante el uso.

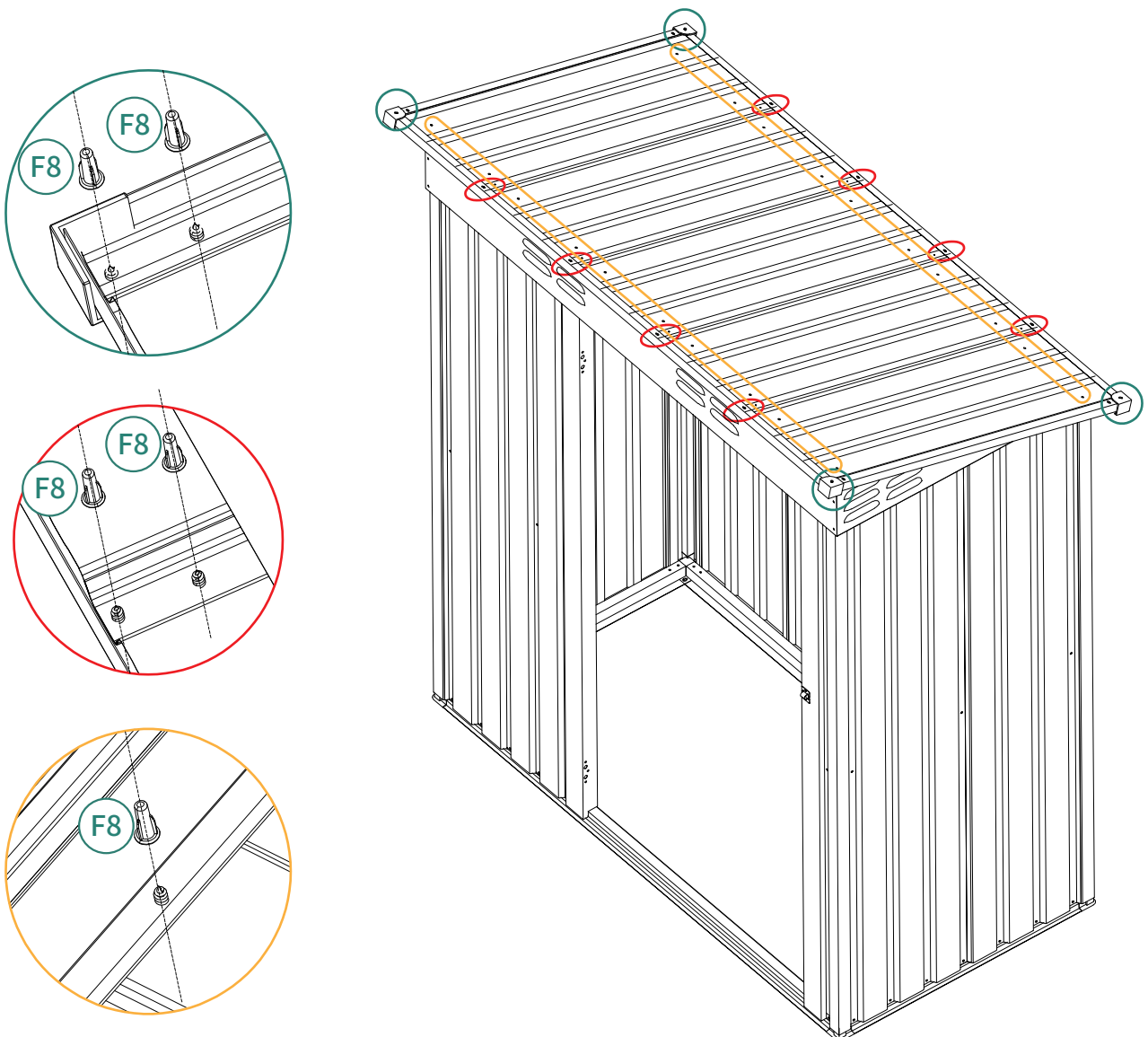

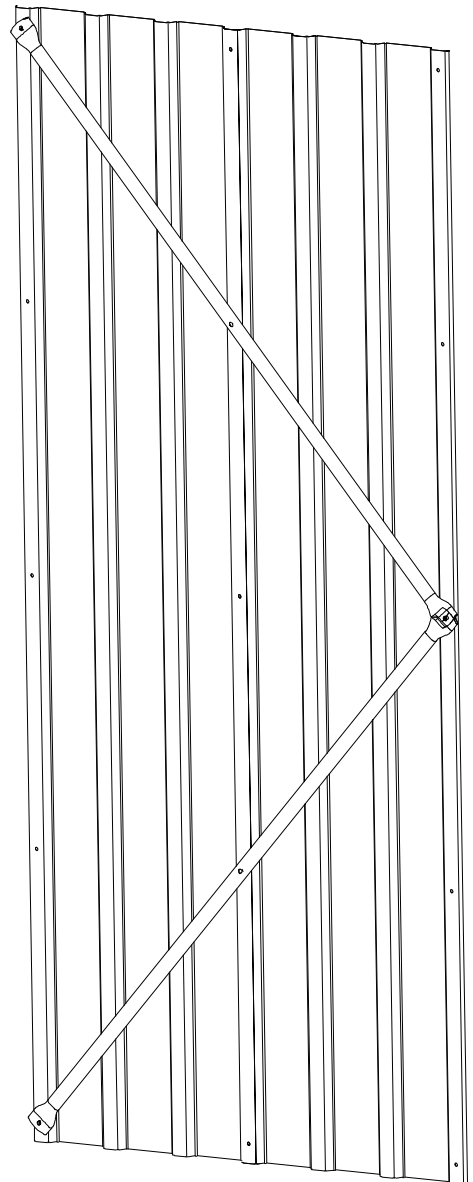
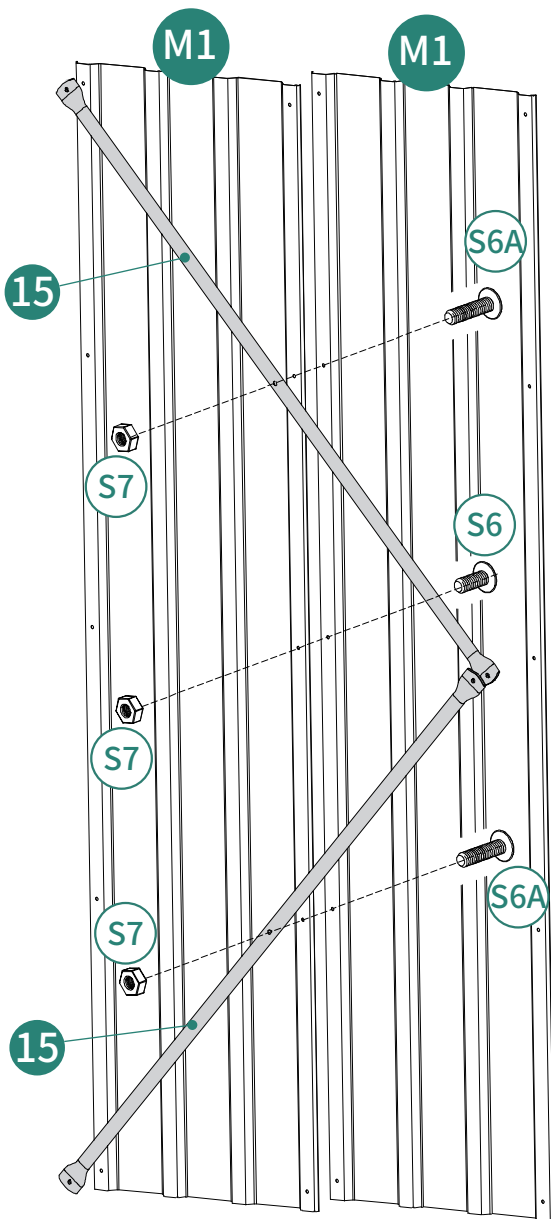

# 16

-  M1 2pcs
-  15 2pcs
-  S6 1pcs
-  S6A 2pcs
-  S7 3pcs





# 18

   
S6 6pcs    S7 6pcs

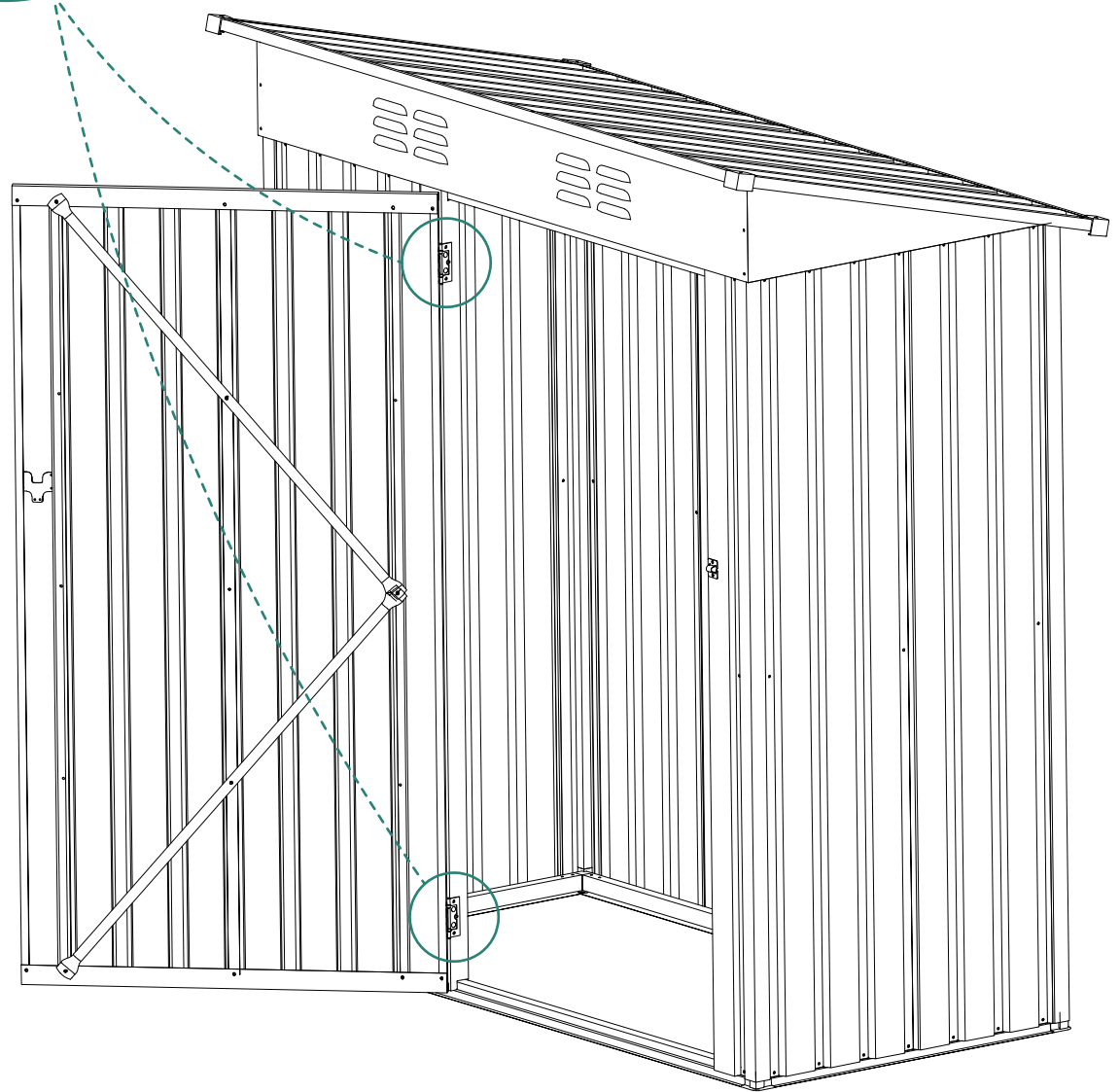
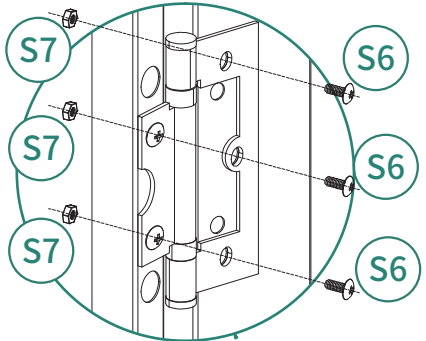

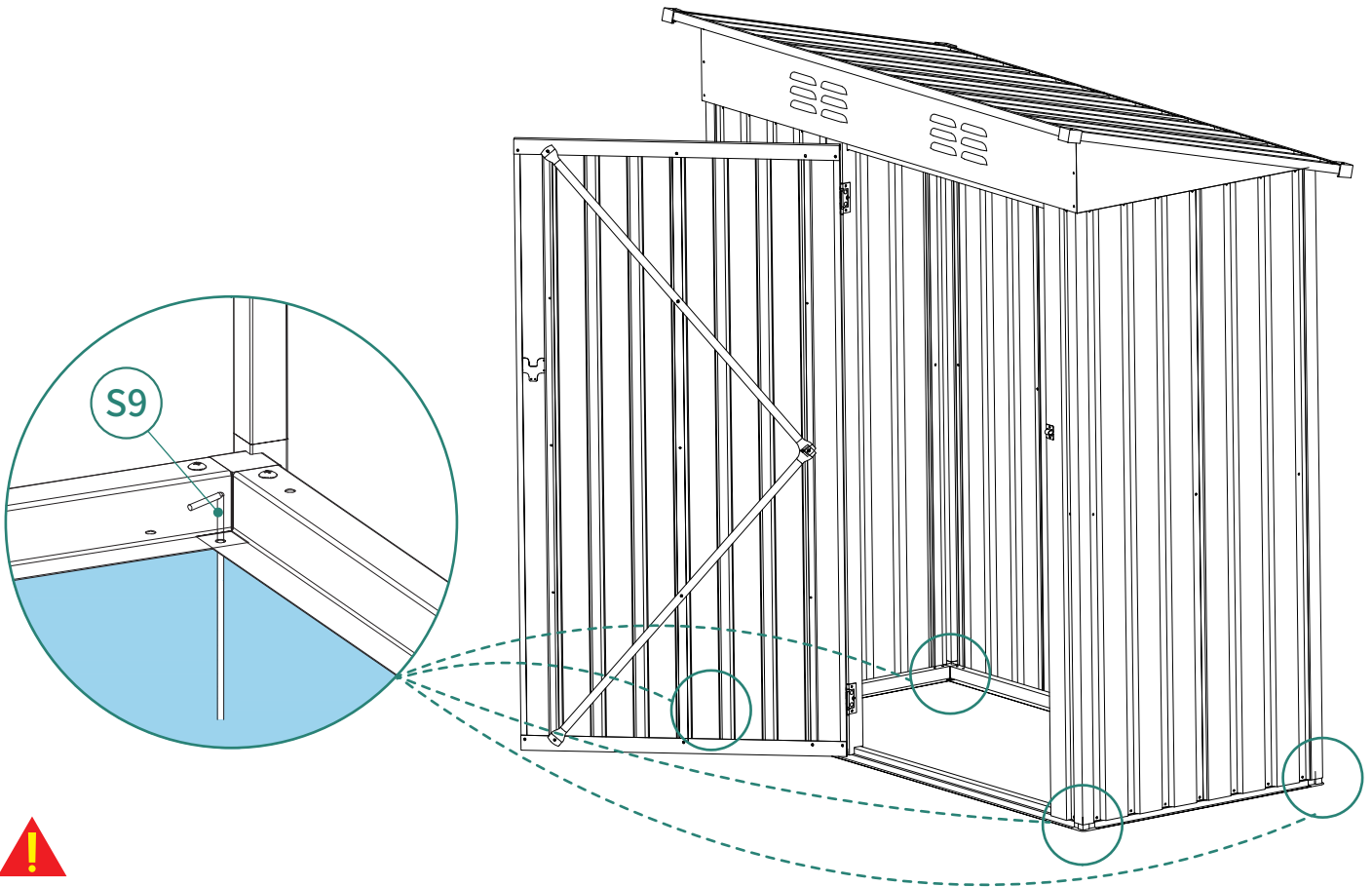

To improve the wind resistance, please be sure to complete this installation step. If expansion bolts or ground stakes are not installed, strong winds may cause the tool shed to collapse. Expansion bolts are crucial for the stability on concrete surfaces, and ground stakes are used for grassy areas. The accessory package includes the ground stake components, but the expansion bolts are not included.

Um die Windbeständigkeit zu verbessern, stellen Sie bitte sicher, dass Sie diesen Installationsschritt abschließen. Wenn Expansionsbolzen oder Bodenanker nicht installiert sind, können starke Winde den Geräteschuppen zum Einsturz bringen. Expansionsbolzen sind entscheidend für die Stabilität auf Betonflächen, und Bodenanker werden für grasbewachsene Bereiche verwendet. Das Zubehörpaket enthält die Bodenankerkomponenten, aber die Expansionsbolzen sind nicht enthalten.

Pour améliorer la résistance au vent, assurez-vous de compléter cette étape d'installation. Si les boulons d'expansion ou les piquets de sol ne sont pas installés, des vents forts peuvent provoquer l'effondrement de l'abri de jardin. Les boulons d'expansion sont cruciaux pour la stabilité sur les surfaces en béton, et les piquets de sol sont utilisés pour les zones herbeuses. Le paquet d'accessoires comprend les composants des piquets de sol, mais les boulons d'expansion ne sont pas inclus.

Per migliorare la resistenza al vento, assicurarsi di completare questo passaggio di installazione. Se i bulloni di espansione o i picchetti non sono installati, i venti forti possono causare il crollo del capanno degli attrezzi. I bulloni di espansione sono cruciali per la stabilità su superfici in cemento, e i picchetti sono usati per le aree erbose. Il pacchetto accessori include i componenti dei picchetti, ma i bulloni di espansione non sono inclusi.

Para mejorar la resistencia al viento, asegúrese de completar este paso de instalación. Si no se instalan los pernos de expansión o las estacas de tierra, los vientos fuertes pueden causar el colapso del cobertizo de herramientas. Los pernos de expansión son cruciales para la estabilidad en superficies de concreto, y las estacas de tierra se utilizan para áreas con césped. El paquete de accesorios incluye los componentes de las estacas de tierra, pero no se incluyen los pernos de expansión.

20

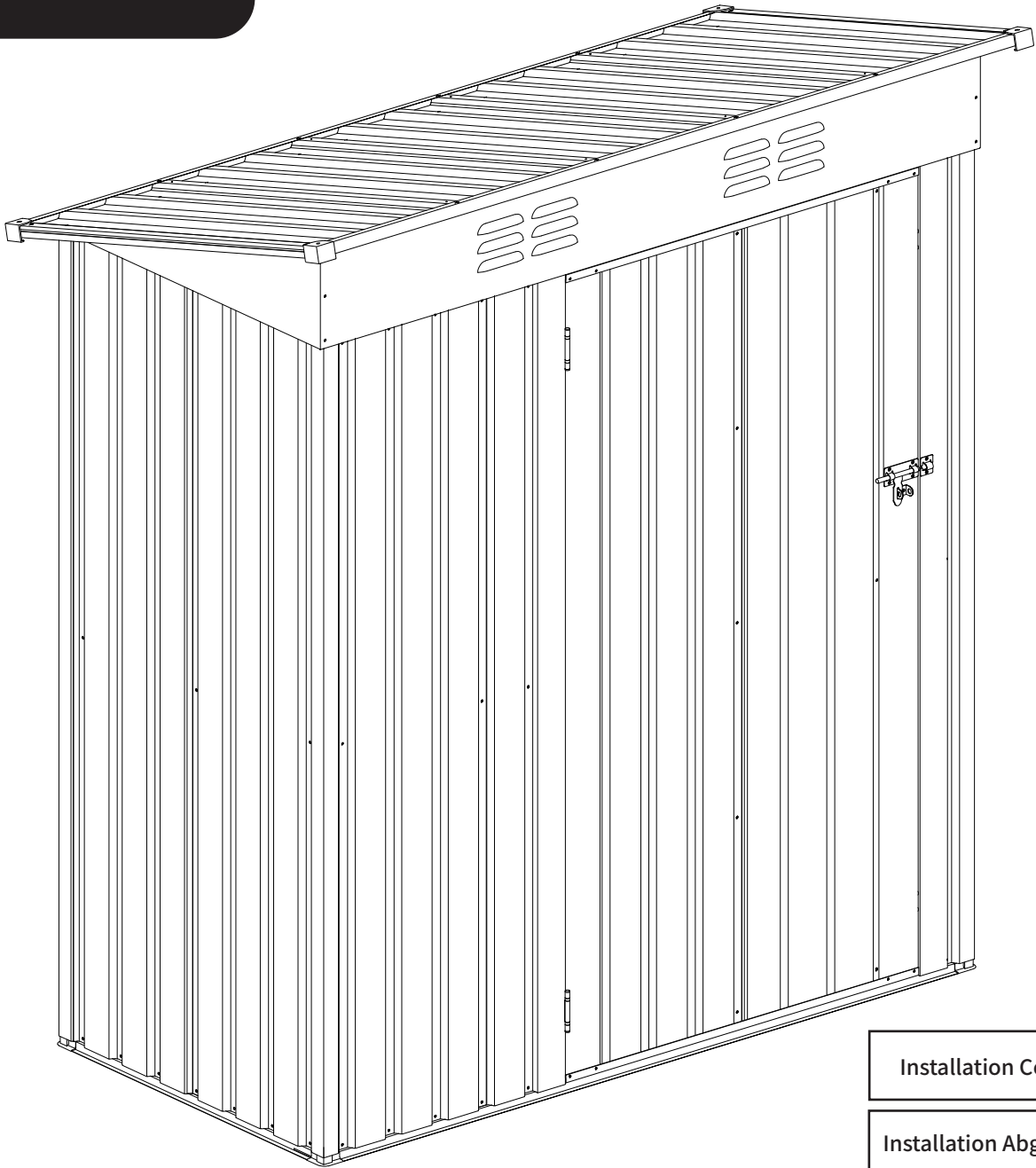

Installation Completed

Installation Abgeschlossen

Installation Complétée

Installazione Completata

Instalación Completada

# HELP CENTER



Inquiry



Assembly issue



Missing parts

If you encounter any difficulties during assembly, please contact us.

Wenn Sie während der Montage auf Schwierigkeiten stoßen, kontaktieren Sie uns bitte.

Si vous rencontrez des difficultés lors du montage, veuillez nous contacter.

Se incontri difficoltà durante il montaggio, ti preghiamo di contattarci.

Si encuentras alguna dificultad durante el ensamblaje, por favor contáctanos.

# DISCLAIMER

Manufacturer and seller expressly disclaim any and all liability for personal injury, property damage or loss, whether direct, indirect, or incidental, resulting from the incorrect attachment, improper use, inadequate maintenance, unapproved modification, or neglect of this product.

Der Hersteller und Verkäufer lehnen ausdrücklich jegliche Haftung für Personenschäden, Sachschäden oder Verluste ab, egal ob direkt, indirekt oder zufällig, die durch falsche Anbringung, unsachgemäßen Gebrauch, unzureichende Wartung, nicht genehmigte Änderungen oder Vernachlässigung dieses Produkts entstehen.

El fabricante y vendedor renuncian expresamente a toda responsabilidad por lesiones personales, daños materiales o pérdidas, ya sean directos, indirectos o incidentales, derivados de la incorrecta colocación, uso inadecuado, mantenimiento insuficiente, modificación no aprobada o negligencia de este producto.

Il produttore e il venditore declinano espressamente ogni responsabilità per lesioni personali, danni materiali o perdite, dirette, indirette o incidentali, derivanti dall'errato fissaggio, uso improprio, manutenzione inadeguata, modifica non autorizzata o negligenza di questo prodotto. Le fabricant et le vendeur déclinent expressément toute responsabilité en cas de blessures corporelles, de dommages matériels ou de pertes, qu'ils soient directs, indirects ou accessoires, résultant de la fixation incorrecte, de l'utilisation inappropriée, de l'entretien insuffisant, de la modification non approuvée ou de la négligence de ce produit.