

Assembly Instructions

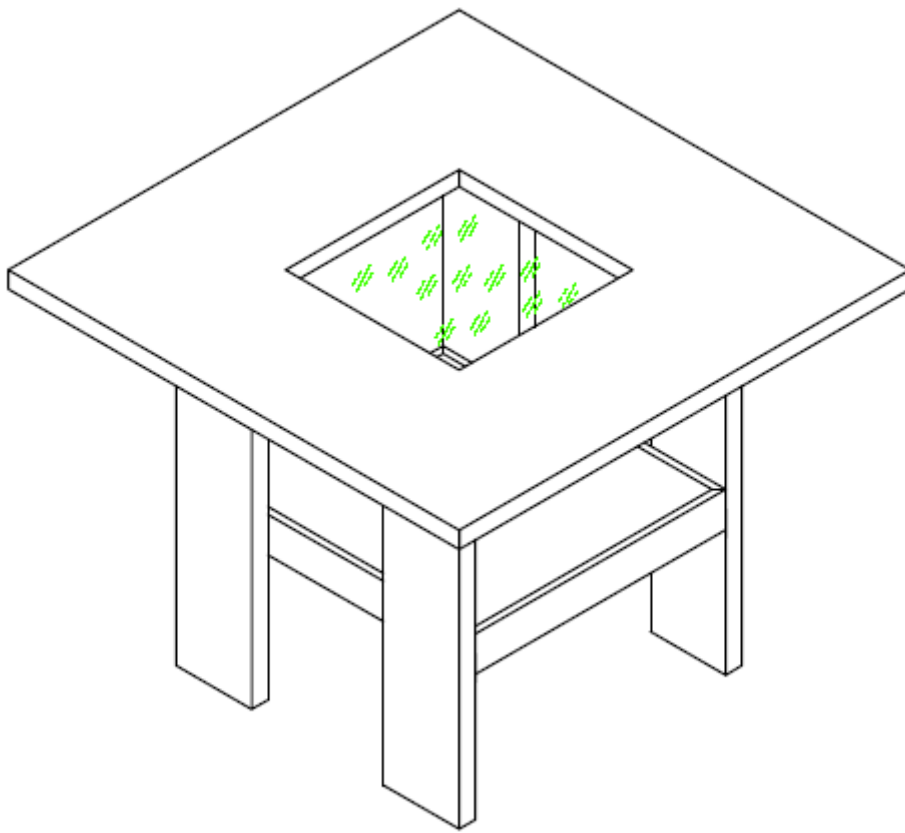

ASSEMBLY RATING

The Assembly Rating is a 5-point system that shows the degree of effort needed in assembling a specific product (with 1 being easy and 5 being difficult). For some products, two persons are recommended.

EASY



DIFFICULT

Tools Required for Assembly:

Allen Wrench



(Included)

Phillips Screwdriver



(Not Included)



2 PERSONS RECOMMENDED

ASSEMBLY & CARE ADVICE

FOR YOUR FURNITURE TO LAST, CORRECT ASSEMBLY AND PROPER MAINTENANCE ARE NECESSARY. PLEASE FOLLOW THE INFORMATION PROVIDED BELOW TO FULLY ENJOY YOUR FURNITURE.

BASIC ASSEMBLY TECHNIQUES

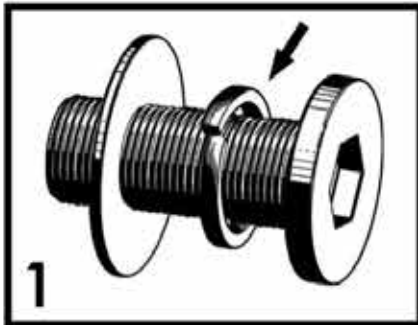

1 When lock or spring washer is used in an assembly, please make sure the lock or spring washer is placed between the larger flat washer and the head of the screw or bolt.

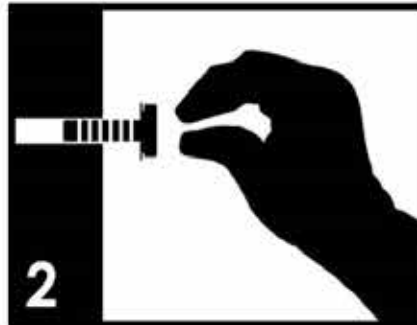

2 Position each part correctly and insert screws or bolts into their respective holes by hand tighten or using the proper hand tool. Only tighten when step is completed or when instructed to do so.



3 Use cardboard or carpet area when assembling furniture to prevent scratches. Make sure the furniture rests on a flat and level surface with each leg evenly touching the floor.

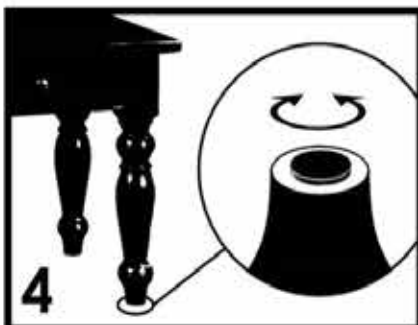

4 Some furniture comes with height adjustment knobs underneath each leg. To lower or to raise each leg, you need to turn clockwise or counterclockwise, respectively.

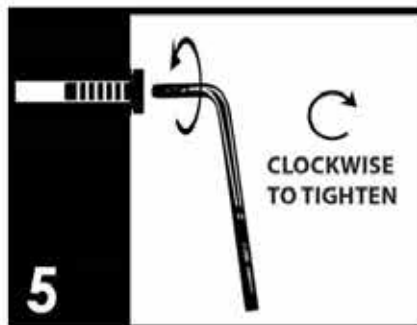

5 Make sure all parts are properly aligned, then use the appropriate hand tool to completely tighten the bolts or screws. Do not use power tools and do not overtighten.



6 Save the instructions and store the Allen wrench or any supplied tool for later maintenance. After two weeks, check and tighten any loose hardware and repeat again every six months thereafter.

IT IS THE USER'S RESPONSIBILITY TO MAINTAIN THE FURNITURE. THE HARDWARE MAY LOOSEN OVER TIME AND MAY CAUSE THE FURNITURE TO BE WOBBLY AND UNABLE TO SUPPORT ITS INTENDED WEIGHT CAPACITY. THIS MAY LEAD TO COLLAPSE AND MAY CAUSE SERIOUS INJURY.



FAILURE TO FOLLOW THE GUIDELINES ABOVE MAY RESULT IN INJURY AND/OR PROPERTY DAMAGE.



Before you begin, please read Page 3 of "Assembly and Care Advice".

And remember, do not tighten until each step is completed or instructed.

MD

Parts List



#1 x 1 pc
Table Top

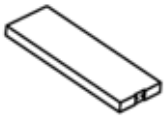

#2 x 4 pcs
Leg



#3 x 1pc
Shelf

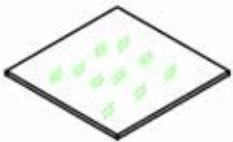

#4 x 1 pc
Glass Top

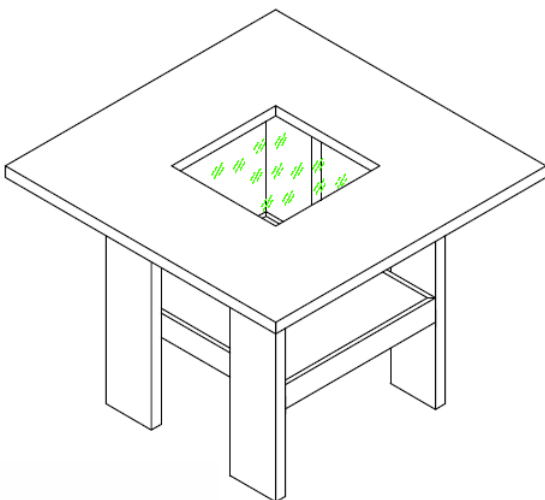

Hardware List



#A x 8 pcs
Bolt 5/16"x7/8"

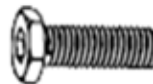

#B x 8 pcs
Bolt 5/16"x7/8"



#C x 8 pcs
Bolt 5/16"x1-1/4"



#D x 16 pcs
Flat Washer



#E x 16 pcs
Lock Washer



#F x 1 pc
Allen Wrench



#G x 4 pcs
Bracket



Due to the size and/or weight of this product, it is highly recommended that the assembly should be done near the area of its intended location. Make sure you have enough space to move around during the assembly. ALWAYS have at least two people to help with transporting and assembling the product to avoid any potential injury and/or damage.



#1

#A x 8 pcs
#G x 4 pcs

Turn right (clockwise) to tighten

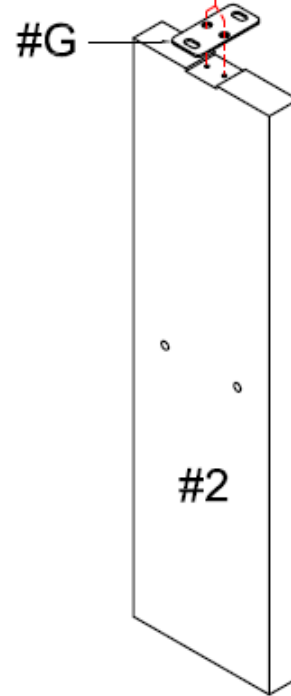
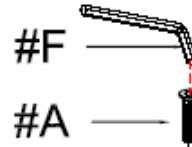

X4

- I. Align the bracket (#G) with the pre-drilled holes of the leg (#2).
- II. Secure the brackets (#G) using the Allen wrench (#F) to tighten the 4 bolts (#A) to lock them with the leg (#2).
- III. Repeat the process above for the remaining 3 legs.



#2

- I. Align the shelf (#3) with the pre-drilled holes of the 4 legs (#2).
- II. Prepare 8 bolt assemblies by inserting FIRST the lock washer (#E) onto the bolt (#C) and then the flat washer (#D) onto the SAME bolt (#C), in that order.
- III. Insert the bolt assemblies through the holes of the shelf (#3) and secure those bolts using the Allen wrench (#F) to lock them with the 4 legs (#2).

#C x 8 pcs
#D x 8 pcs
#E x 8 pcs

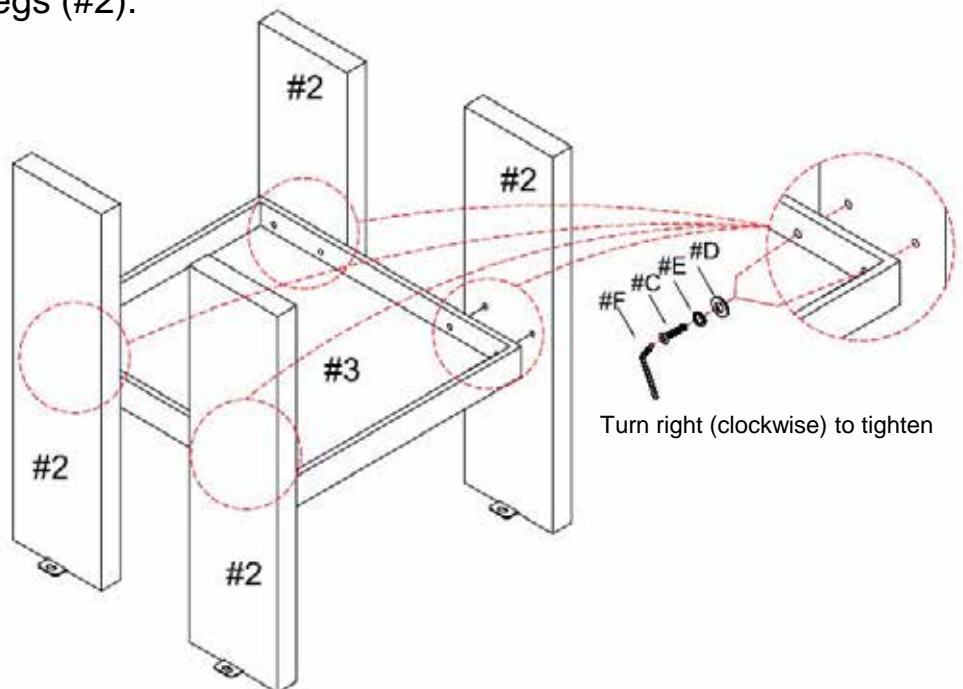

Turn right (clockwise) to tighten



- I. With the help of another person, carefully place the table top (#1) facing down on a protective surface. Align the assembled legs/shelf with the pre-drilled holes on the table top (#1).
- II. Prepare 8 bolt assemblies by inserting FIRST the lock washer (#E) onto the bolt (#B) and then the flat washer (#D) onto the SAME bolt (#B), in that order.
- III. Insert the bolt assemblies through the holes of the brackets (#G) and secure those bolts using the Allen wrench (#F) to lock them with the table top (#1).

#B x 8 pcs
#D x 8 pcs
#E x 8 pcs

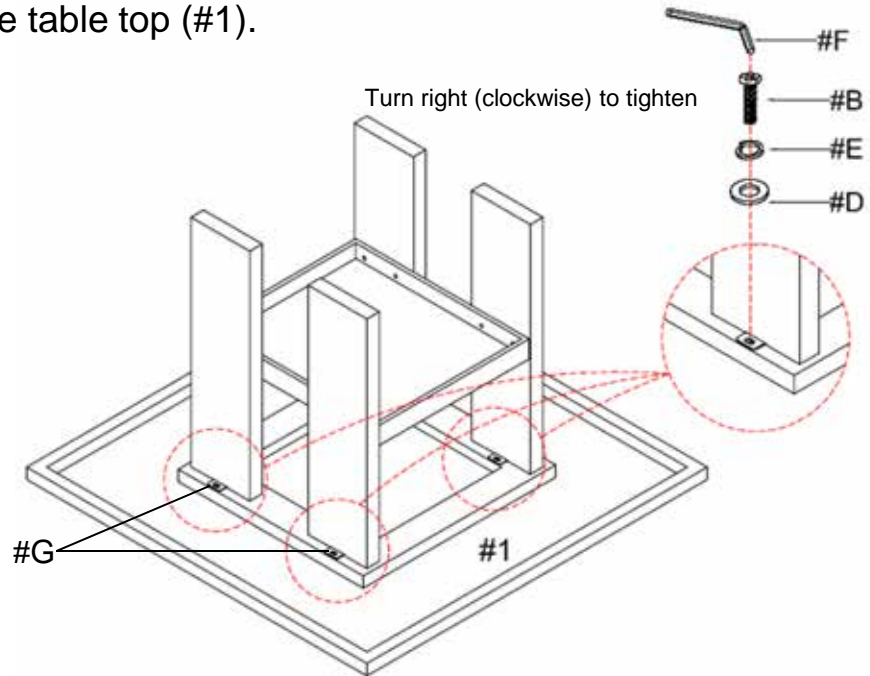

Place the glass top (#4) onto the table top (#1). Make sure the table is rested on a flat surface and does not feel loose or wobbly. If it does, double check that the bolts/screws are secured and properly tightened.

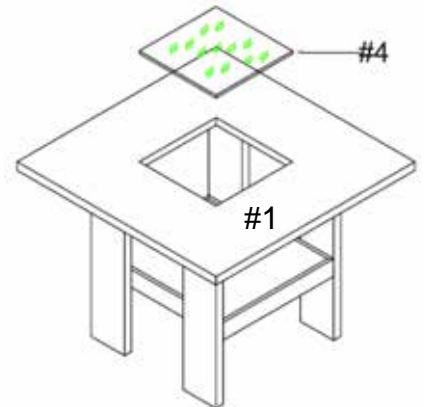

To install the batteries (not included), remove the screw that holds the battery cover by using a Phillips screwdriver. Install new AA-size 1.5-volt alkaline batteries with correct polarity (+,-) by following the illustration inside the battery cover. Close the battery cover and tighten back the screw.

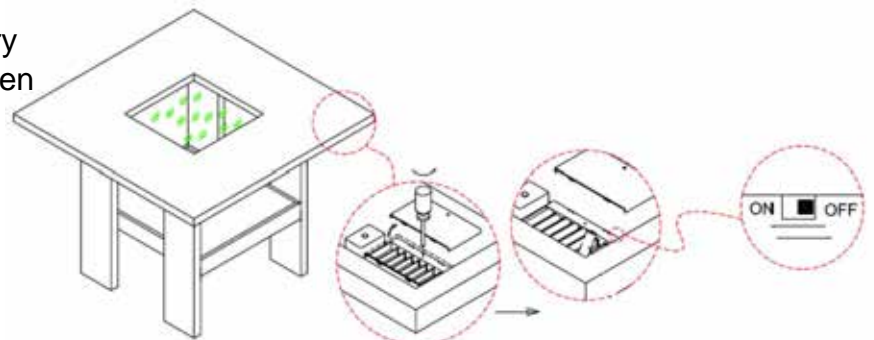

Caution:

- Use batteries of the same type.
- Do not mix old and new batteries.
- Do not mix alkaline, standard (carbon-zinc), or rechargeable (nickel-cadmium) batteries.
- Do not use rechargeable batteries.
- Do not try to recharge non-rechargeable batteries.
- Remove exhausted or corroded batteries.
- If light is not used for more than a week, remove the batteries to prevent depletion and corrosion.