

ASSEMBLY INSTRUCTION

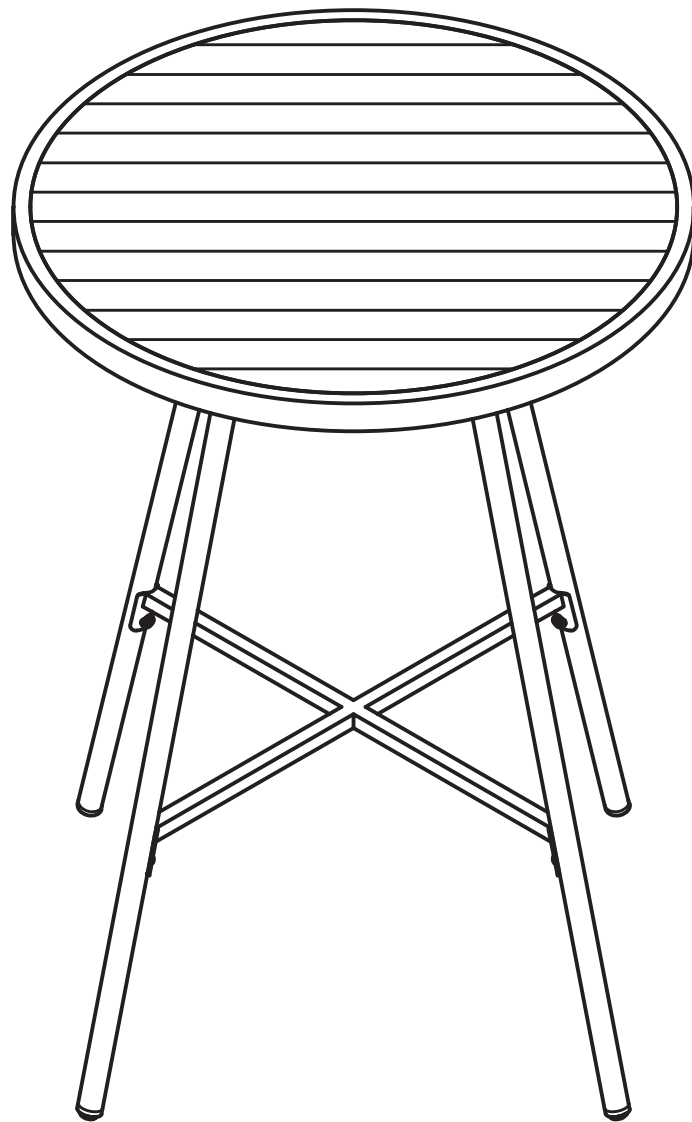

Bar table

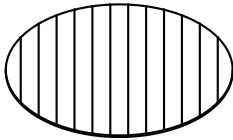
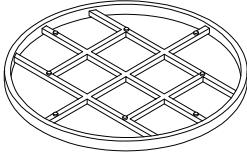
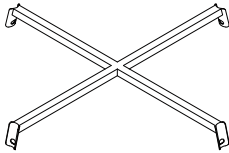
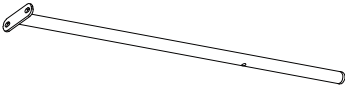

Component List

LABEL		DESCRIPTION	QTY
A		Table Top	1
B		Table Frame	1
C		Cross	1
D		Table leg	4

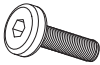
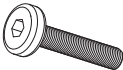
Hardware List

LABEL		DESCRIPTION	QTY
#1		Bolts M6 x 15 mm	+1 Spare 8
#2		Bolts M6 x 20 mm	+1 Spare 4
#3		Flat washer M6	+1 Spare 12
#4		Allen wrench M6	1

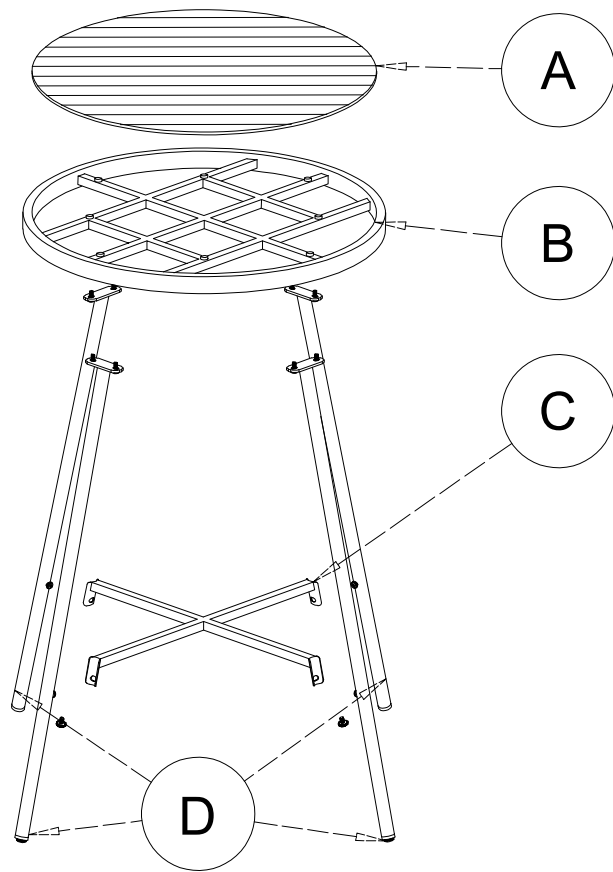

1

#1 × 8PCS

 M6 *15 MM

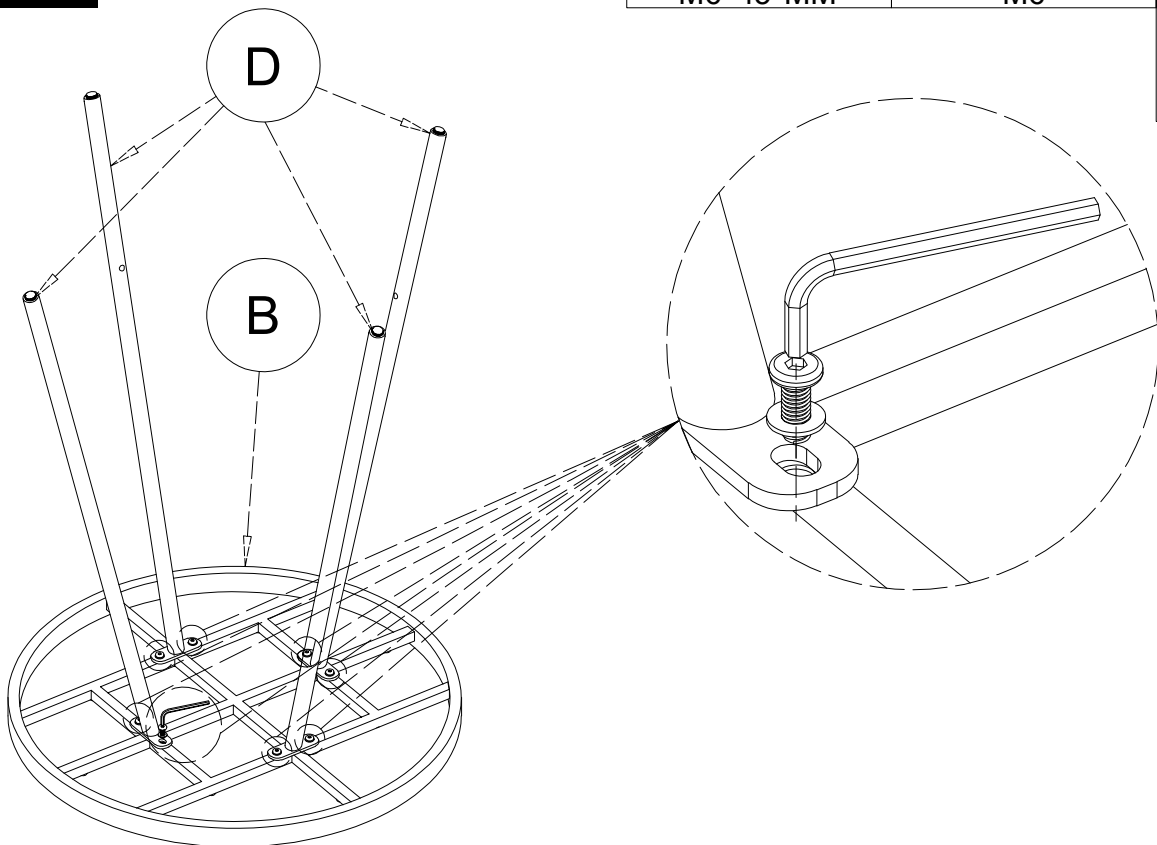
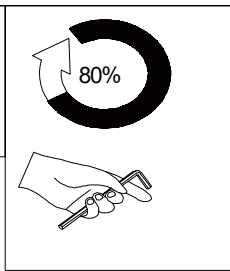
#2 × 8PCS

 M6



2

#1 × 4PCS



M6× 20MM

#2 × 4PCS



M6

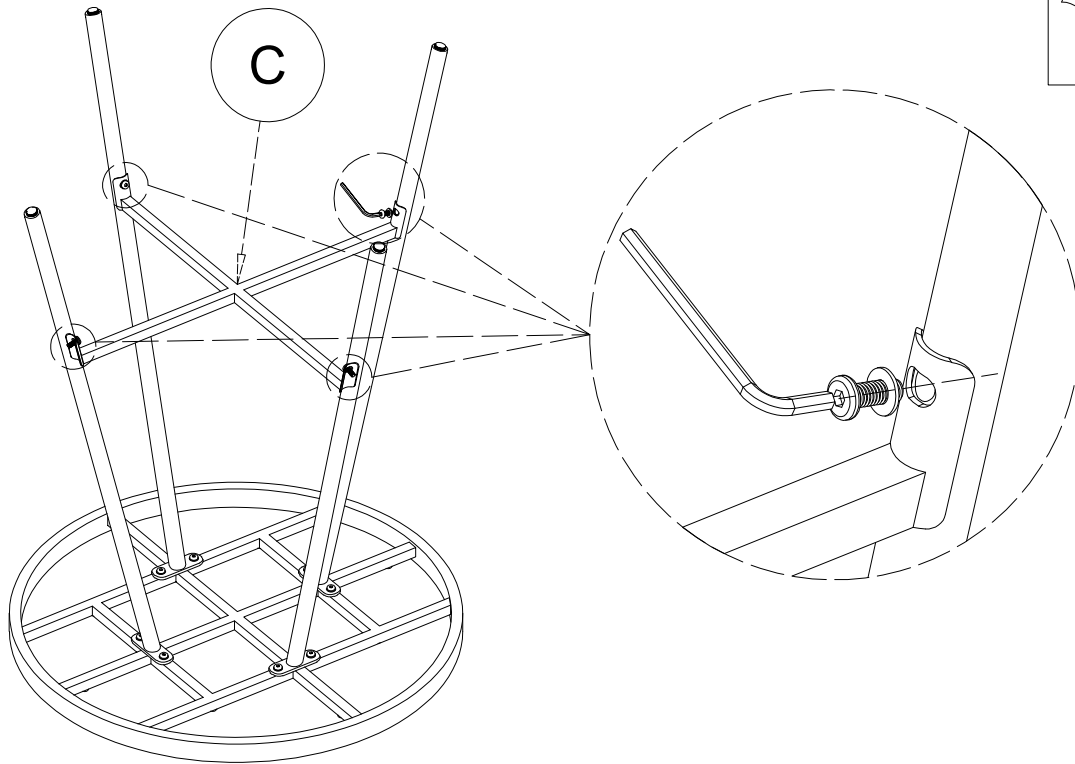
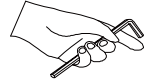
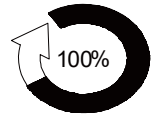

3

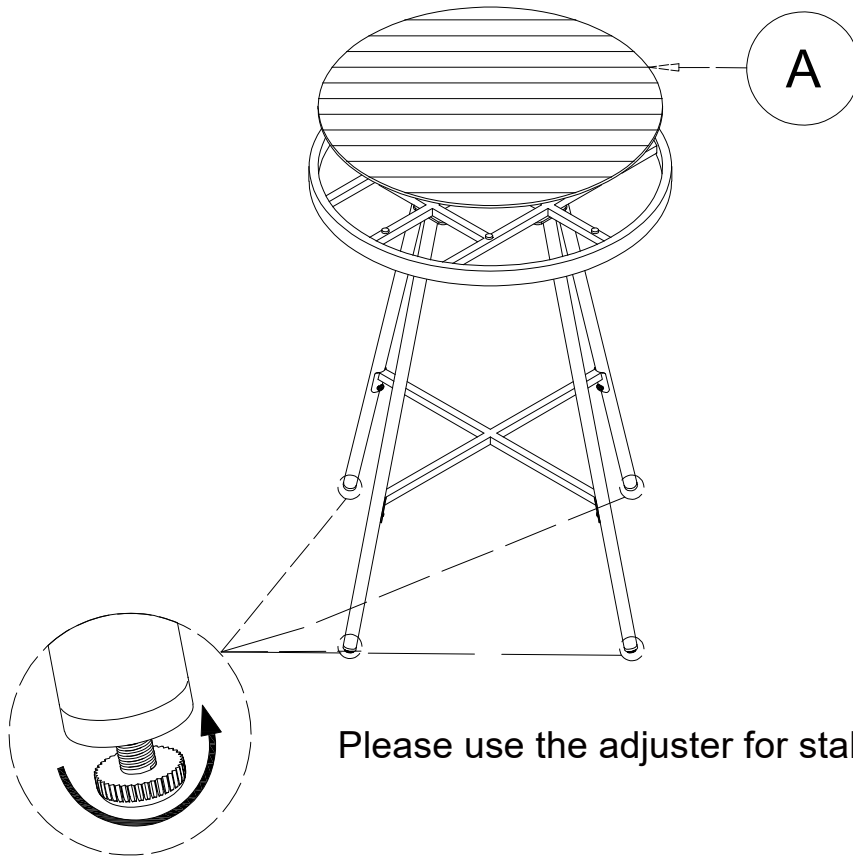

Please use the adjuster for stability if needed.