



Parts and Damage Replacement Procedure

1. Please inspect your purchase immediately.
2. This procedure covers product purchased from an authorized Roundhill Reseller and was received in its originally sealed carton.
3. If you find a part missing or damaged, you have a 30-day window in which to order a replacement part from the date on your purchase receipt.
4. You have 3 ways to do this. You will need a copy of your purchase receipt.
 - a. By Fax: Fax the parts order form below and along with your receipt to 614-878-7918
 - b. By Email: Email the order form and along with your receipt to: parts@roundhillfurniture.com
 - c. By Mail: Fill out the parts order form below and along with a copy of your receipt send it to Roundhill furniture parts department 3640 Zane Trace Drive, Columbus OH 43228
5. Once this order is sent in, you will be notified if the part(s) you are requesting can or cannot be shipped within 7-10 business days.

**A COPY OF YOUR PURCHASE RECEIPT OR INVOICE MUST BE ATTACHED TO THIS ORDER FORM.
NO ORDERS WILL BE PROCESSED WITHOUT PROOF OF PURCHASE.**

NAME: _____
 ADDRESS: _____ (No Post Office Boxes)
 CITY: _____ STATE: _____ ZIP: _____
 PHONE: _____ FAX: _____
 EMAIL: _____

REASON FOR REPLACEMENT/PLEASE CHECK APPROPRIATE BOX.

- Damaged /scratched, cracked, broken, crushed, etc.
- Mechanical malfunction/ drawer glides, swivel mechanisms, lid stays, etc.
- Missing pieces
- Unfinished surface
- Wrong color
- Other

IF MORE THAN ONE MODEL NUMBER IS LISTED ABOVE, PLEASE SPECIFY THE EXACT MODEL NUMBER OF YOUR ITEM IN THE SPACE PROVIDED BELOW.









Model Number	Part Letter Code	Quantity

ITEM NO.B5109 KING BED

ASSEMBLY INSTRUCTIONS

MODEL : B5109K-HB & B5109K-FB & B5109KQ-LR
 DESCRIPTION : KING / CAL. KING FABRIC HEADBOARD W/LED LIGHTS
 +KING / CAL.KING PANEL FOOTBOARD W/ 5 SLATS, 10 SUPPORTS
 +QUEEN / KING PANEL SIDERAIL SET (2)

Thank you for purchasing this quality product.Be sure to check all packing material carefully for small Hardware which may have come loose inside the carton during shipment.Identify and count all Hardware and compare with the Hardware List below

Component List			
Headboard & Footboard & Side rail			
NO	Descriptions		Qty
A	Headboard Panel		1
B	Headboard Left Leg		1
C	Headboard Right Leg		1
D	Footboard		1
E	Footboard Left Leg		1
F	Footboard Right Leg		1
G	Side Rail		2
H	Slat Support		10
I	Slat		5

HARDWARE LIST IN HEADBOARD			
NO.	Description		Q'ty
1		Bolt 5/16"*45mm	6
2		Spring Washer 5/16"*12mm	6
3		Flat Washer 5/16"*19mm	6
4		Allen Key 4mm	1
HARDWARE LIST IN FOOTBOARD			
NO.	Description		Q'ty
5		Bolt 5/16"*45mm	4
6		Spring Washer 5/16"*12mm	4
7		Flat Washer 5/16"*19mm	4
8		Allen Key 4mm	1
9		Screw 5/32"*1 1/4"	10
HARDWARE LIST IN SIDE RAIL			
NO.	Description		Q'ty
10		Bolt 5/16"*20mm	8
11		Spring Washer 5/16"*12mm	8
12		Flat Washer 5/16"*19mm	8
13		Allen Key 4mm	1

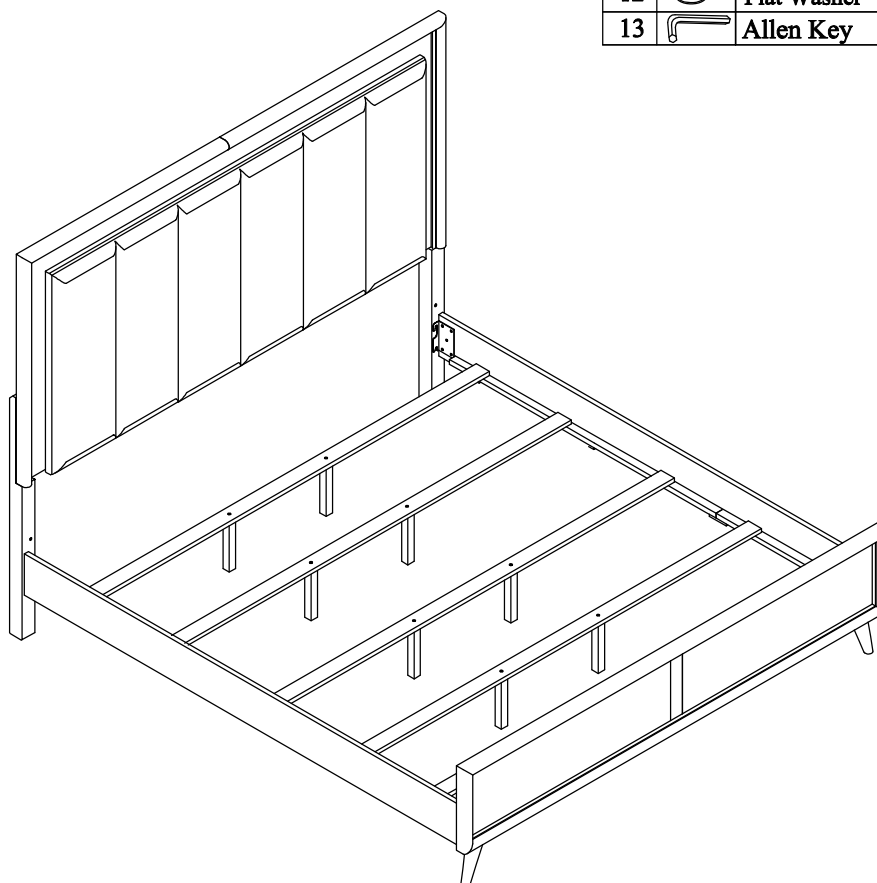

ASSEMBLY INSTRUCTIONS

MODEL : *B5109K-HB & B5109K-FB & B5109KQ-LR*

DESCRIPTION : *KING / CAL. KING FABRIC HEADBOARD W/LED LIGHTS*

+KING / CAL.KING PANEL FOOTBOARD W/ 5 SLATS, 10 SUPPORTS

+QUEEN / KING PANEL SIDERAIL SET (2)

Thank you for purchasing this quality product. Be sure to check all packing material carefully for small Hardware which may have come loose inside the carton during shipment. Identify and count all Hardware and compare with the Hardware List below

STEP 1 : Attach & tighten the Headboard Leg (B) & (C) to the Headboard Panel (A). Affix Headboard & Headboard Leg using Bolt 5/16"*45 (1), Spring Washer (2), Flat Washer (3) using Allen Key M4 (4)

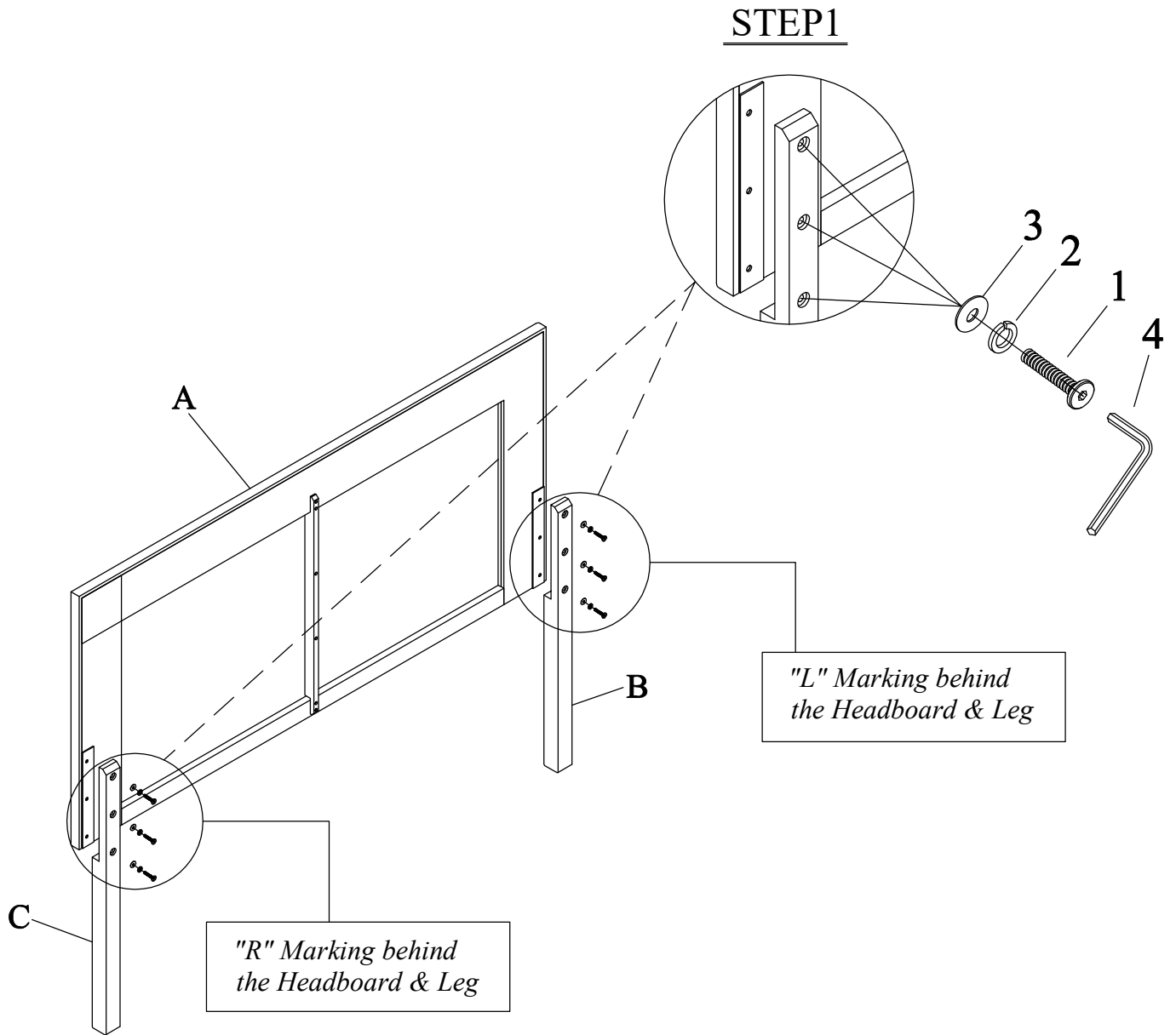

ASSEMBLY INSTRUCTIONS

MODEL : B5109K-HB & B5109K-FB & B5109KQ-LR

DESCRIPTION : KING / CAL. KING FABRIC HEADBOARD W/LED LIGHTS
+KING / CAL.KING PANEL FOOTBOARD W/ 5 SLATS, 10 SUPPORTS
+QUEEN / KING PANEL SIDERAIL SET (2)

Thank you for purchasing this quality product.Be sure to check all packing material carefully for small Hardware which may have come loose inside the carton during shipment.Identify and count all Hardware and compare with the Hardware List below

STEP 2 : Attach & tighten the *Footboard Leg* (E)&(F) to the *Footboard Panel* (D). Affix *Footboard & Footboard Leg* using Bolt 5/16"*32 (5), Spring Washer (6), Flat Washer (7) using L Key M4 (8)

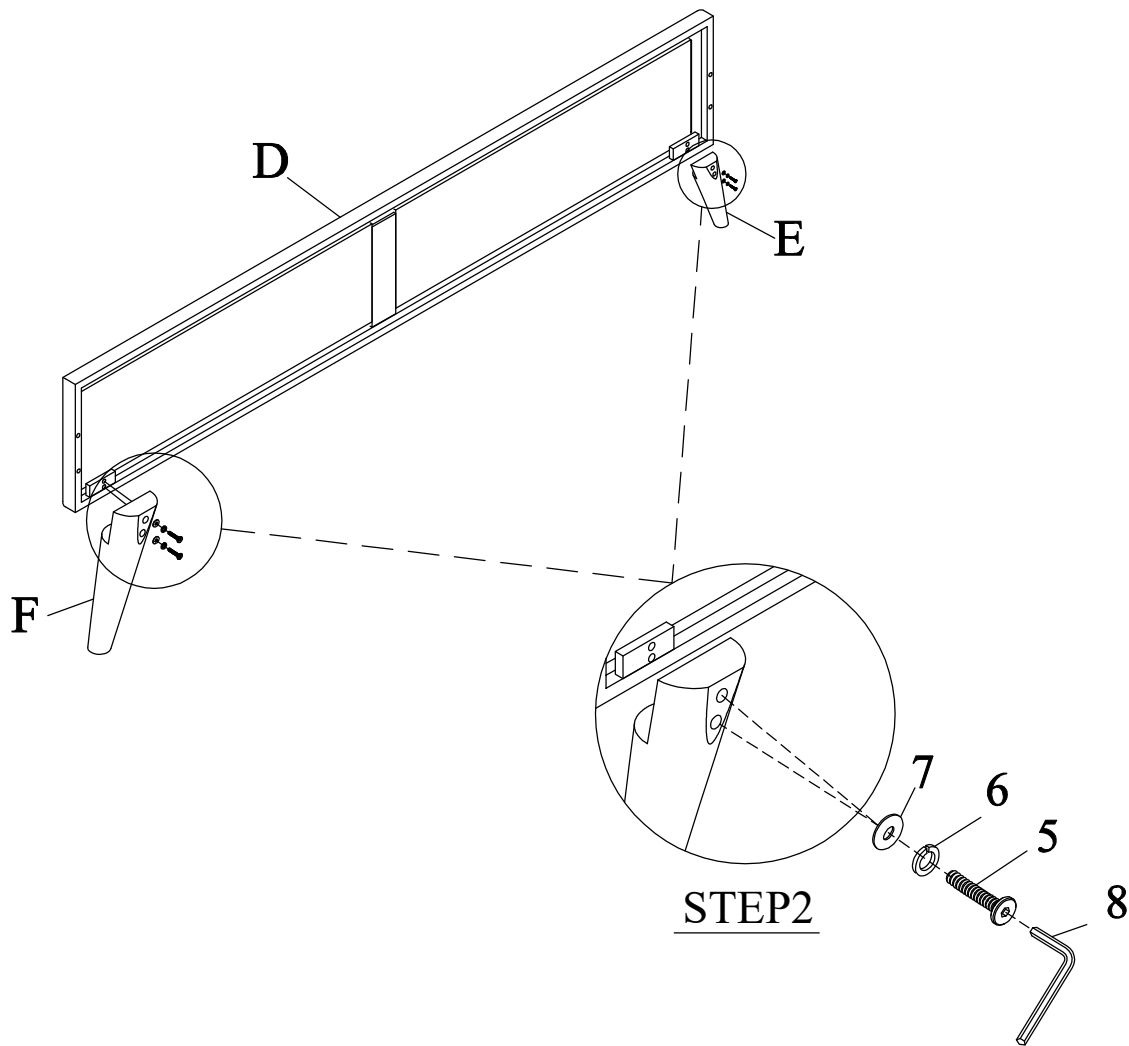

ASSEMBLY INSTRUCTIONS

MODEL : *B5109K-HB & B5109K-FB & B5109KQ-LR*

DESCRIPTION : *KING / CAL. KING FABRIC HEADBOARD W/LED LIGHTS*

+KING / CAL.KING PANEL FOOTBOARD W/ 5 SLATS, 10 SUPPORTS

+QUEEN / KING PANEL SIDERAIL SET (2)

Thank you for purchasing this quality product. Be sure to check all packing material carefully for small Hardware which may have come loose inside the carton during shipment. Identify and count all Hardware and compare with the Hardware List below

STEP 3 : Attach the Side Rail (G) to Headboard Leg R/L (B)&(C). Tighten screw on Headboard Leg by using Bolt 5/16"*20 (10) & repeat the same step on Footboard (D).

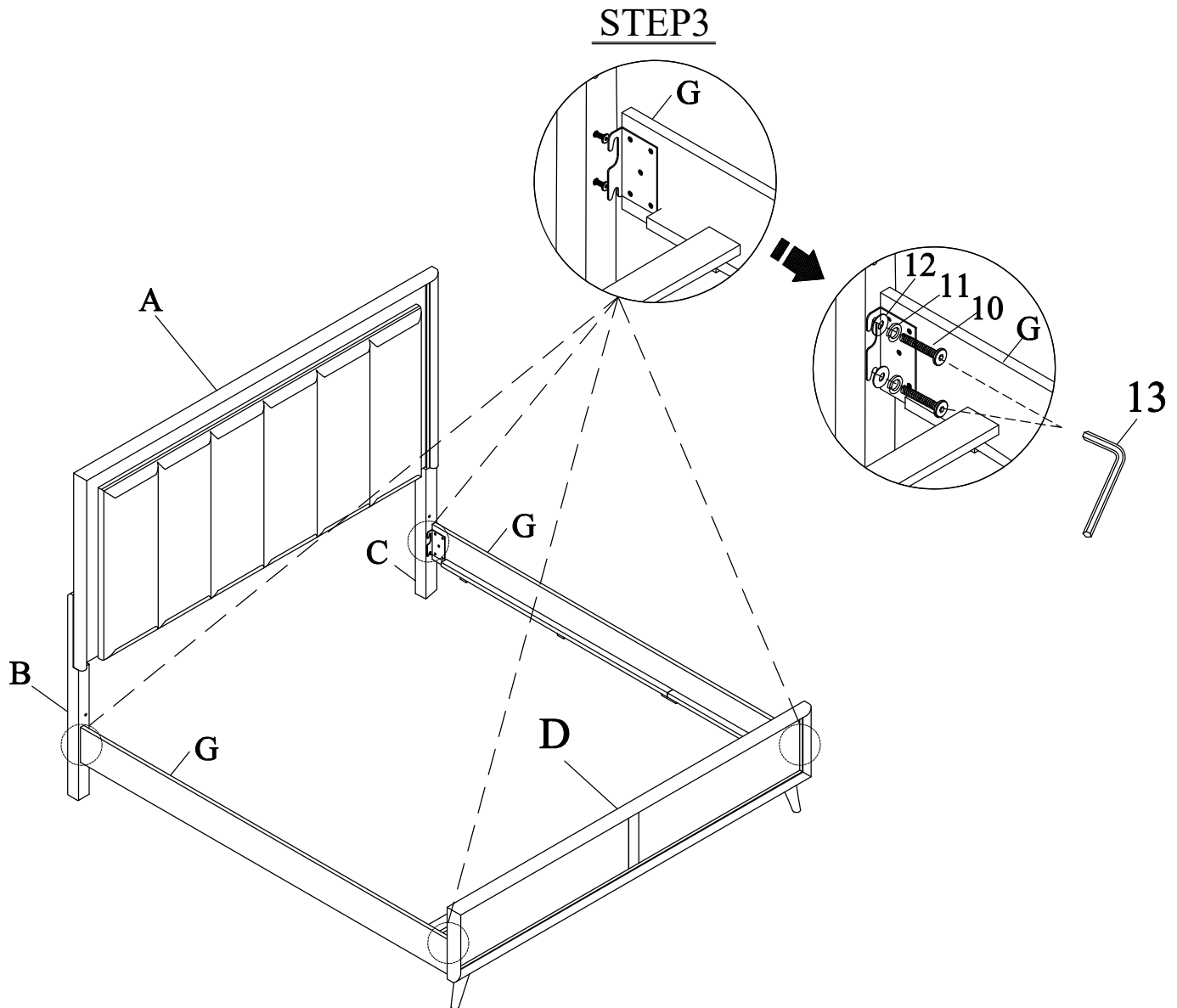

ASSEMBLY INSTRUCTIONS

MODEL : B5109K-HB & B5109K-FB & B5109KQ-LR

DESCRIPTION : KING / CAL. KING FABRIC HEADBOARD W/LED LIGHTS
+KING / CAL.KING PANEL FOOTBOARD W/ 5 SLATS, 10 SUPPORTS
+QUEEN / KING PANEL SIDERAIL SET (2)

Thank you for purchasing this quality product. Be sure to check all packing material carefully for small Hardware which may have come loose inside the carton during shipment. Identify and count all Hardware and compare with the Hardware List below

STEP 4 : Attach the Bed Slat Support (H) to the bottom of each Bed Slat (I).

STEP 5 : Attach Bed Slat (I) and tighten to Side Rail (G) with Screw 5/32" x 32mm (9).

