

Assembly Instructions

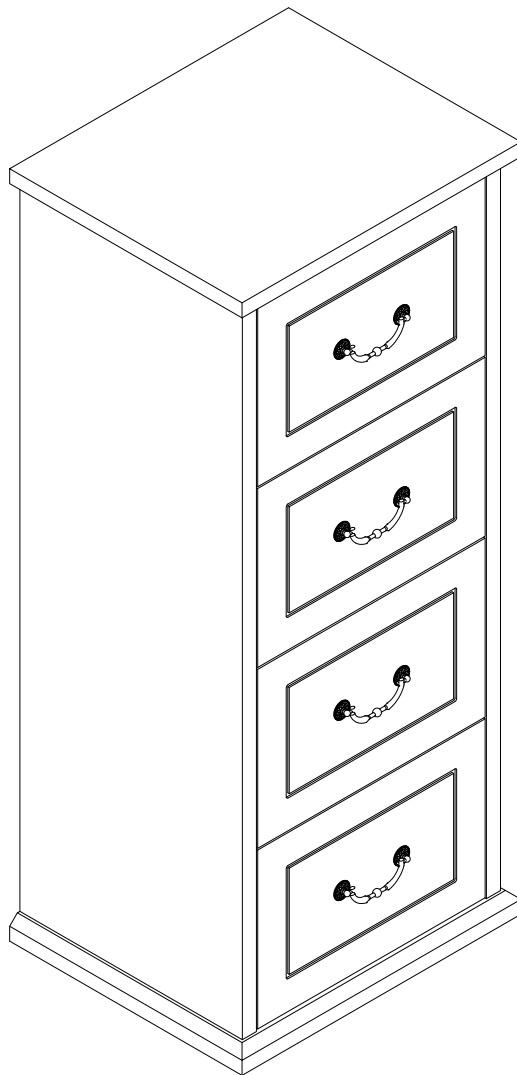

File Cabinet

Model NO:

HOGA-NY281	HOGA-HL0376
HOGA-NY282	HOGA-HL0238

Contact Us

We're here to help you.



Your satisfaction is our top priority. If you encounter any issues with this product, such as missing or damaged parts, we're here to help. Please retain the original packaging and take photos of the packaging and the product, then contact us as soon as possible.

Warm Tips

1. Carefully read these instructions and keep them for future reference.
2. Check the parts list and confirm everything's there before starting assembly.
3. When assembling, put all parts on a soft, smooth surface like a carpet to avoid scratches.
4. Don't fully tighten screws until all parts are confirmed in place to avoid misalignment.

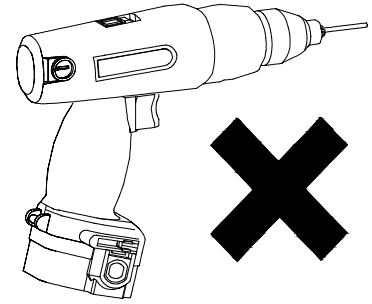
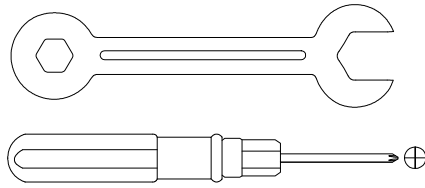
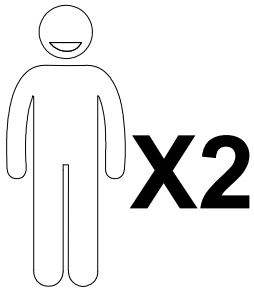

We recommend using hand tools for assembly.

If an electric screwdriver is used, reduce power and torque to avoid damage to the product.

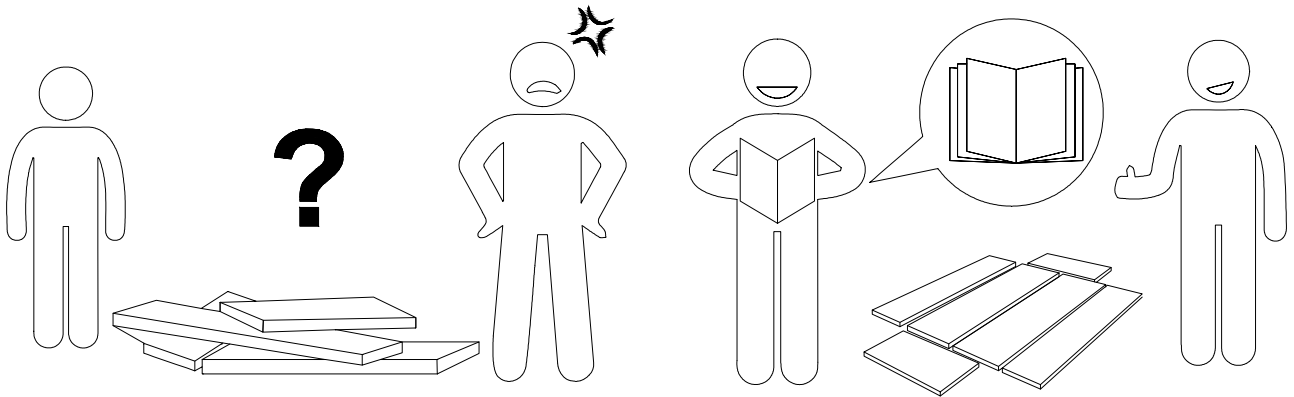

Install the Anti-Tip Straps

Using the anti-tip straps can reduce the risk of tipping over, but can not eliminate it.

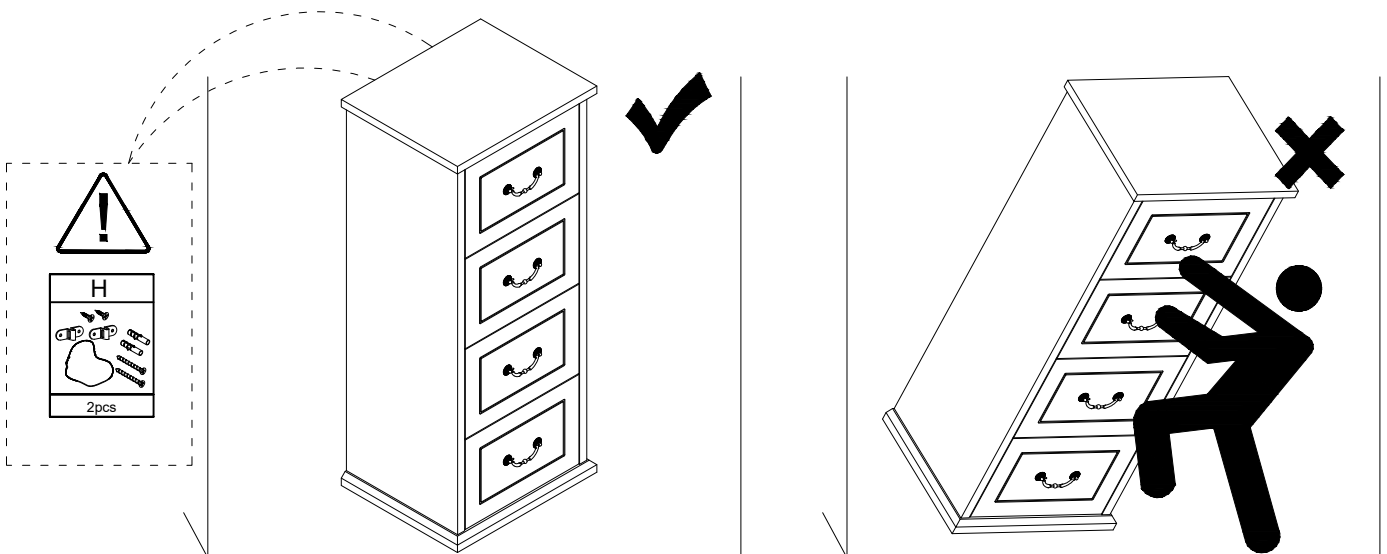

Please split component into "I" and "J" before assembling the slide and then proceed to the next step of assembly

Step 1

Pull apart component to each side, and then gently push up the lever of component "J"

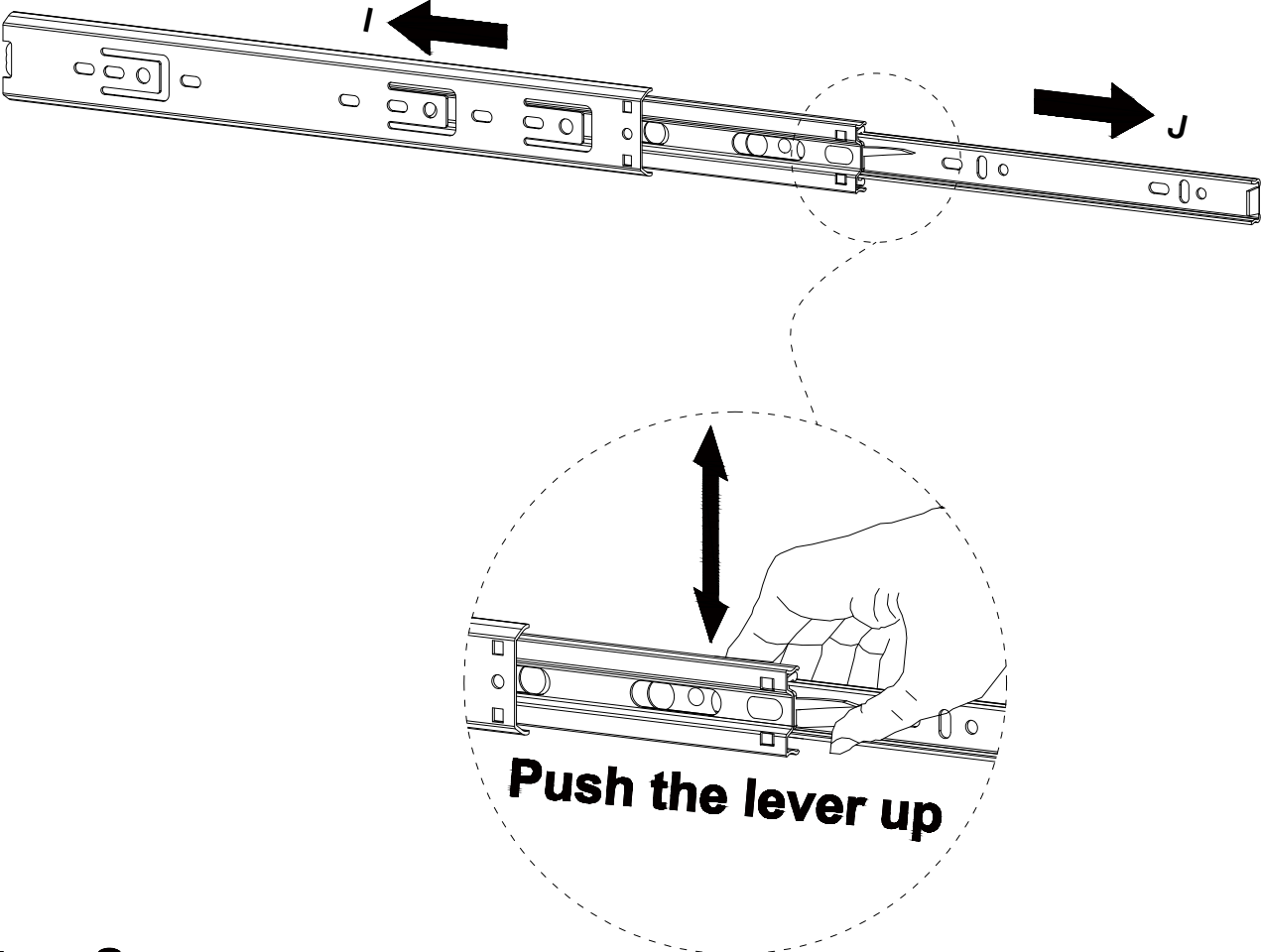

Step 2 Split component "I" and "J"

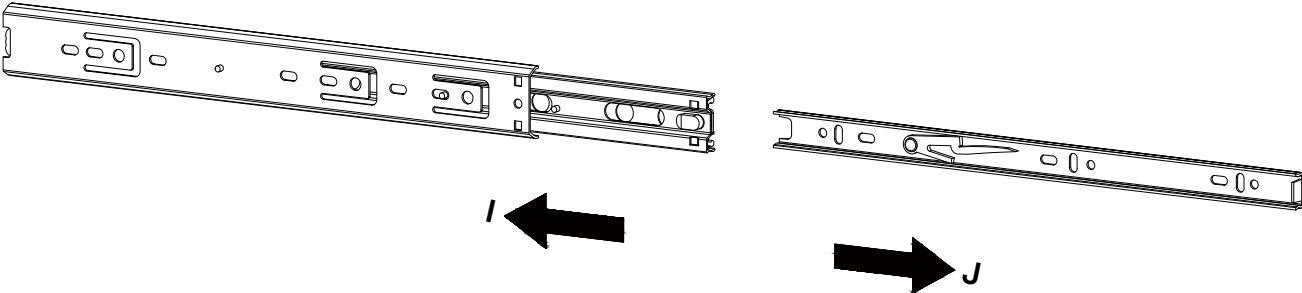

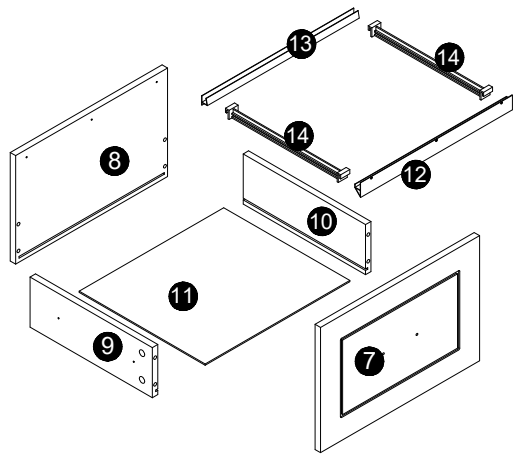
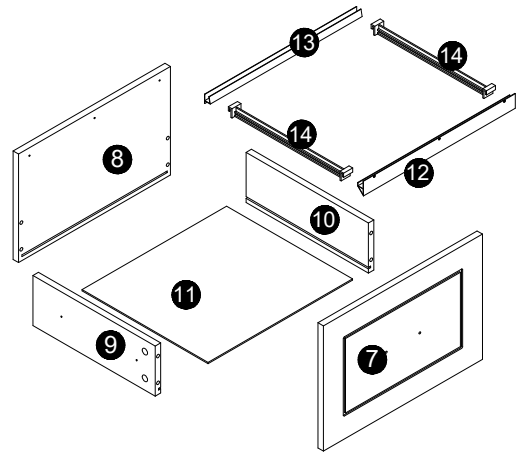
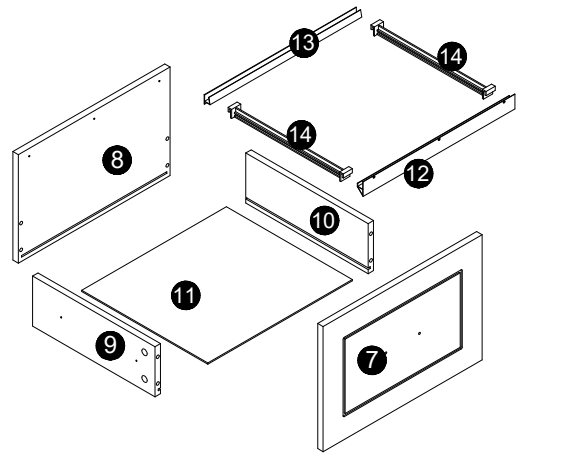
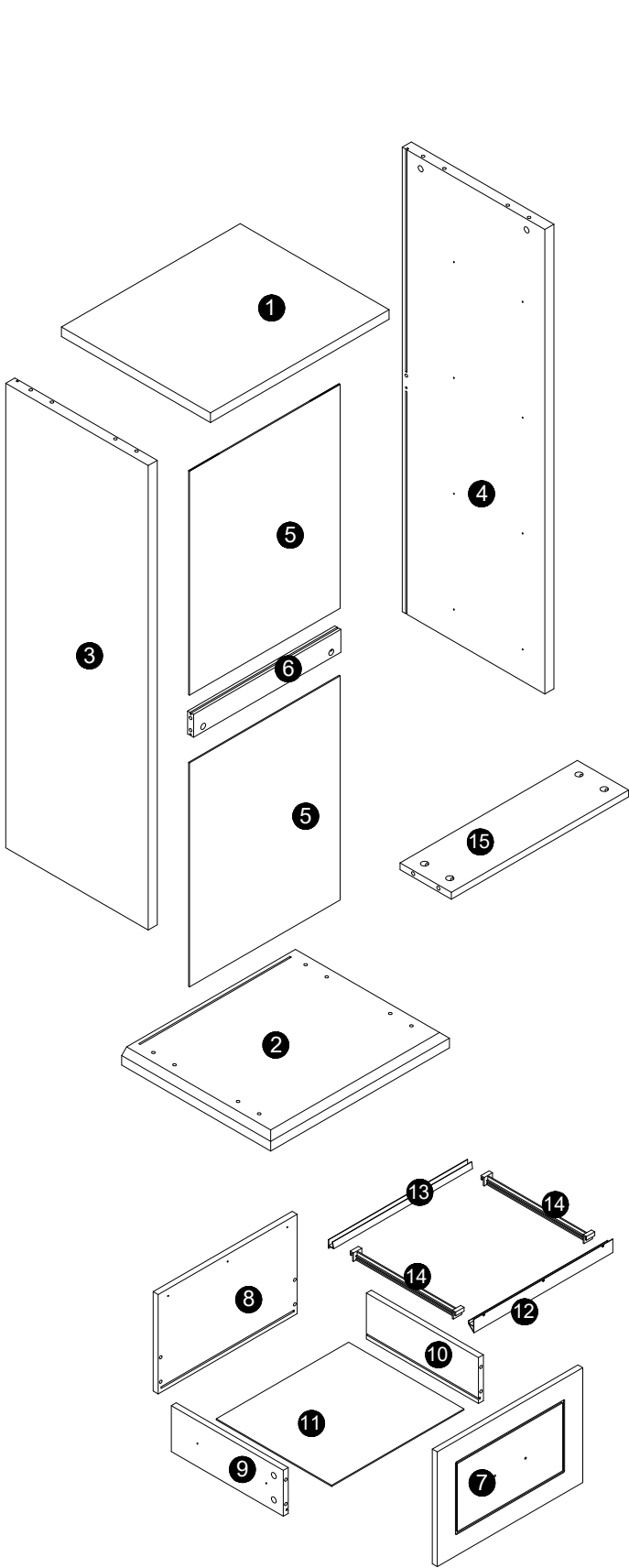







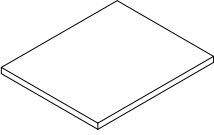
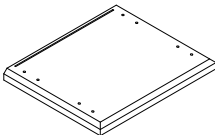

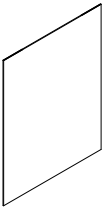
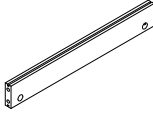
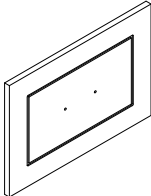
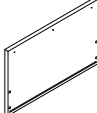
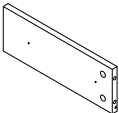
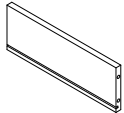
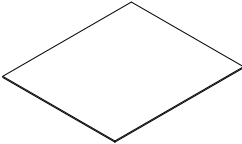
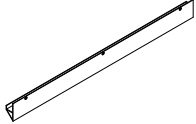
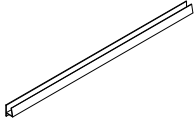
⚠ Caution

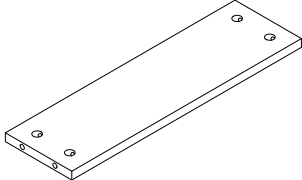

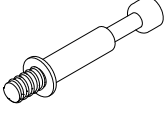
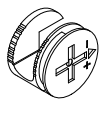

Make sure all parts are included. Most board parts are labeled or stamped on the raw edge. Contact us for a free replacement if you encounter any damaged or missing parts.

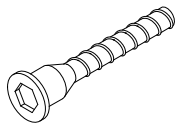
Parts List

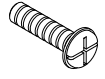
1  1pc	2  1pc	3  1pc	4  1pc
5  2pcs	6  1pc	7  4pcs	8  4pcs
9  4pcs	10  4pcs	11  4pcs	12  4pcs
13  4pcs	14  8pcs	15  1pc	

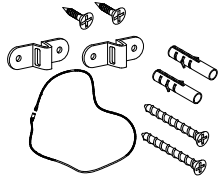
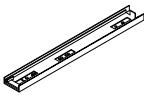
Parts List

A	B	C	D	E	F
					
Ø6x35mm	Ø15x12mm	Ø8x30mm	Ø7x38mm	Ø3.5x14mm	M4x22mm
26pcs+1pc	26pcs+1pc	10pcs+1pc	20pcs+1pc	52pcs+2pcs	8pcs+1pc

G	H	I	J	K	L
					
4mm		290mm	290mm		
1pc	2pcs	8pcs	8pcs	4pcs	8pcs

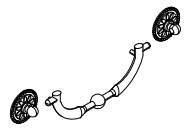
M

4pcs

Installation of Cams and Pins

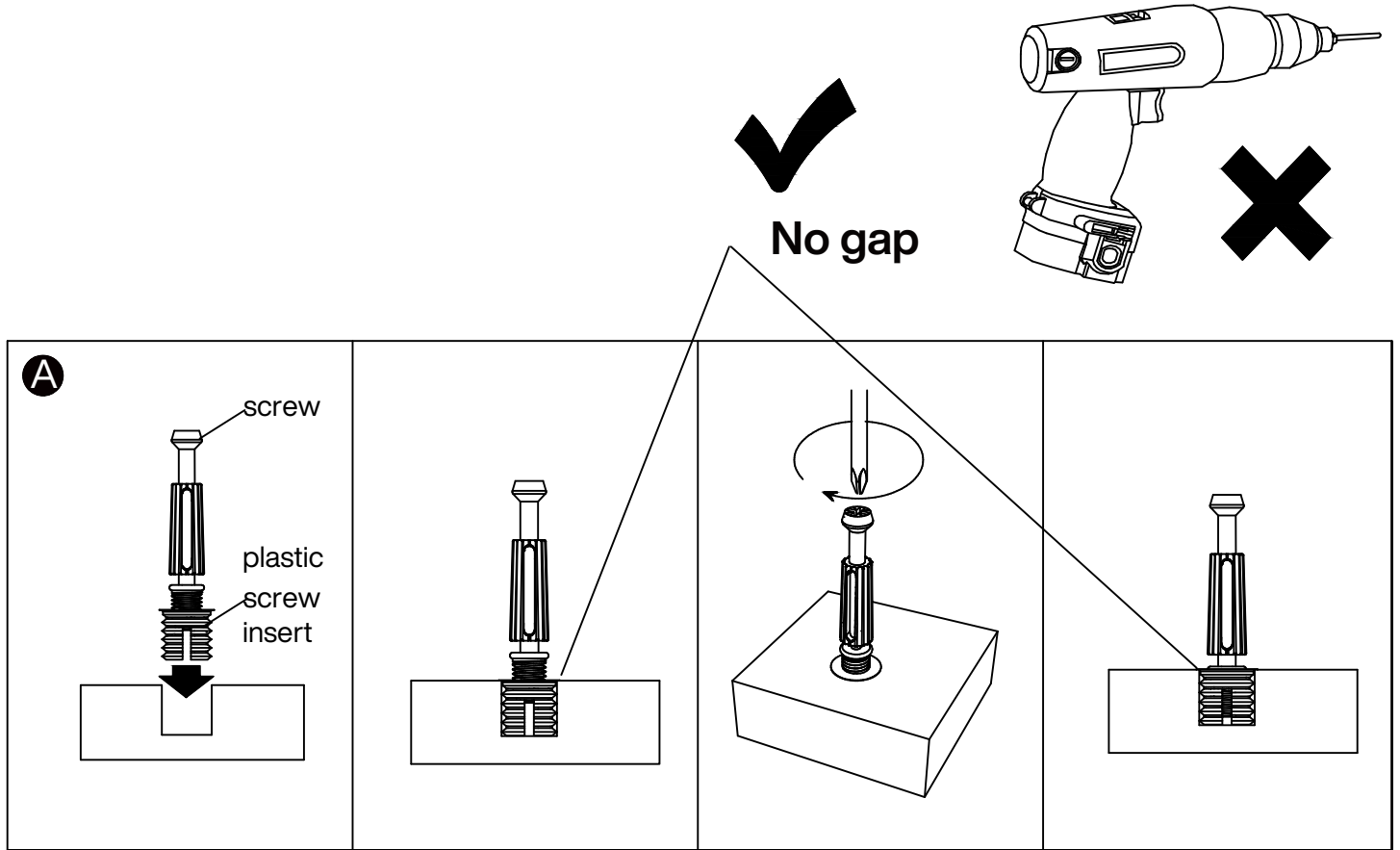
Step 1-2: Align the plastic part with the mounting hole and press it in. If you can't press it in, loosen the screw counter clockwise or completely remove the screw from the plastic part and try again.
Step 3-4: After pressing the plastic part into place, use a screwdriver to tighten the screw clockwise.



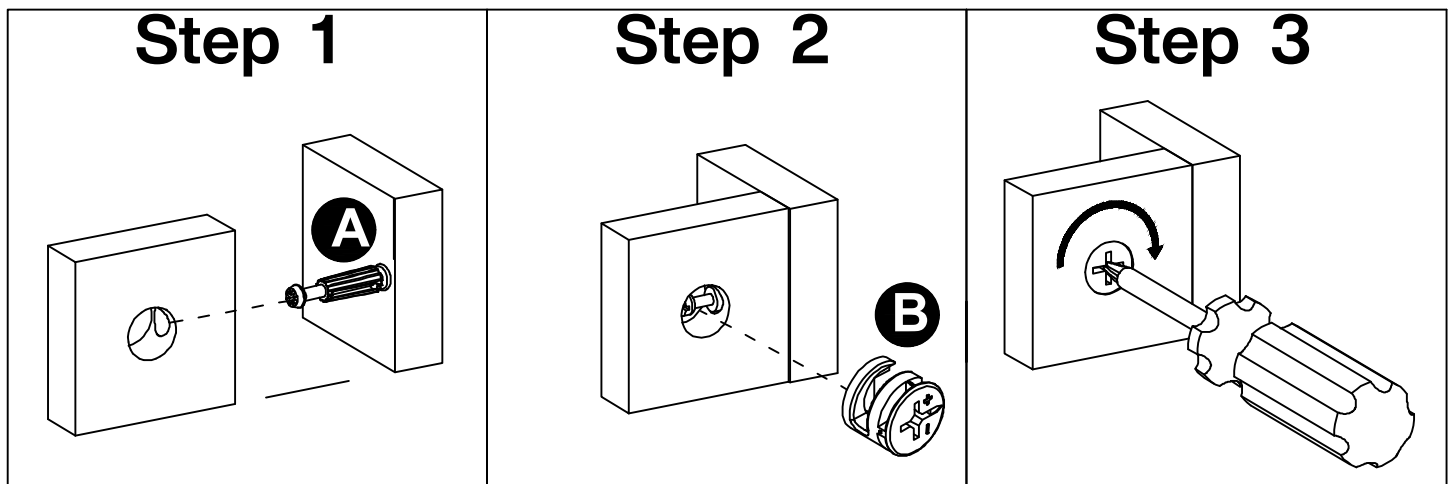

Screw the pin into the hole. Set the cams correctly by aligning the head of the cams with the lock pins. Lock the cam by turning the cam head with a screwdriver until it is tightened. Please do not use an electric screwdriver to assemble the unit.

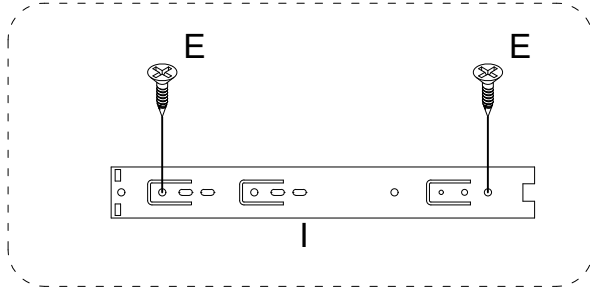

1

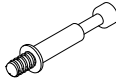

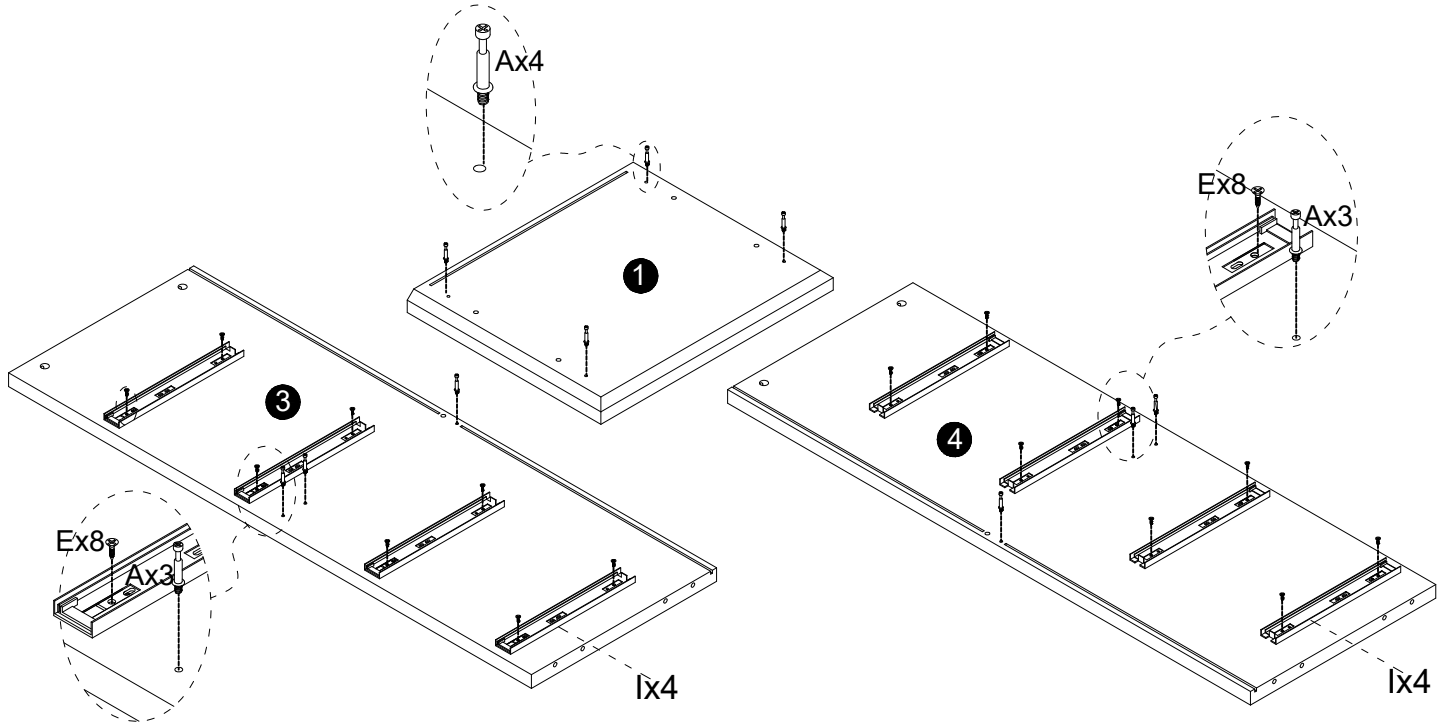

A	E	I
		
Ø6x35mm	Ø3.5x14mm	290mm
10pcs	16pcs	8pcs



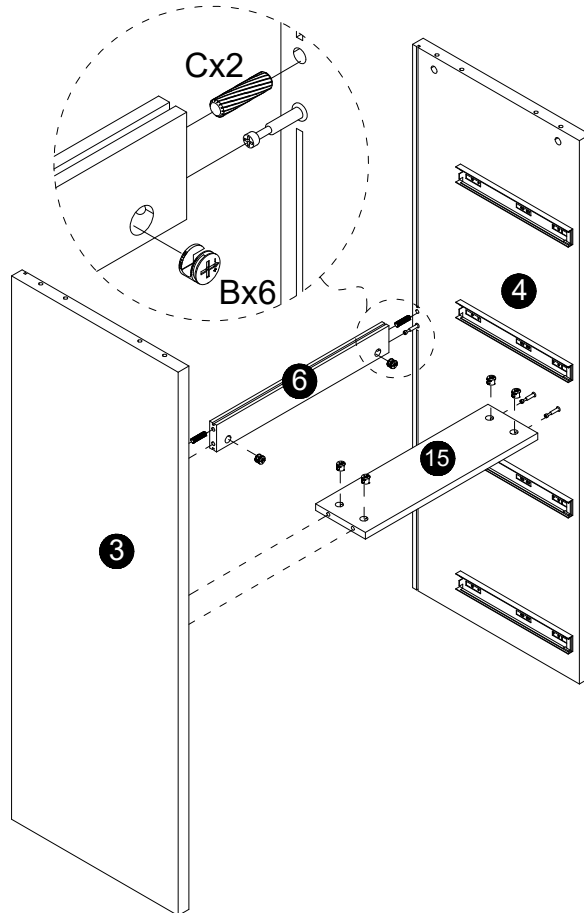

2

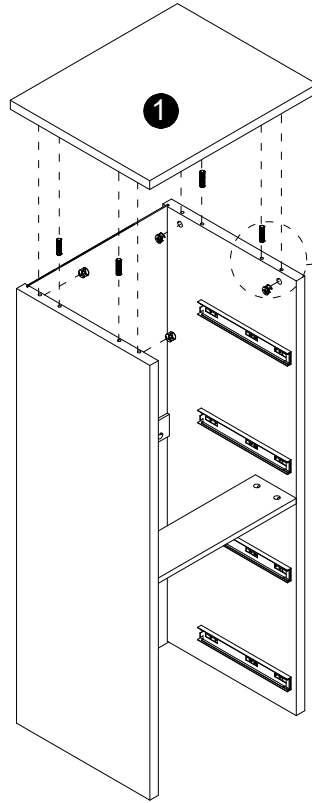
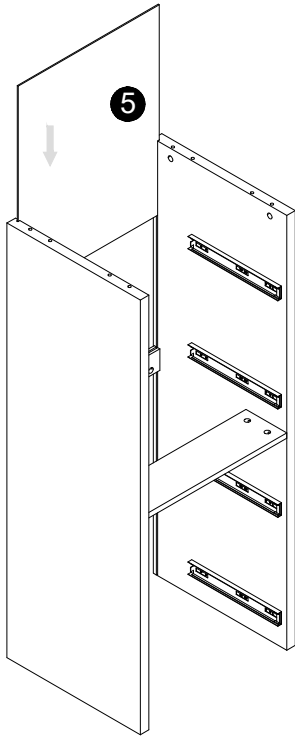

C	B
	
Ø8x30mm	Ø15x12mm
2pcs	6pcs

3



B	C
	
Ø15x12mm	Ø8x30mm
4pcs	4pcs

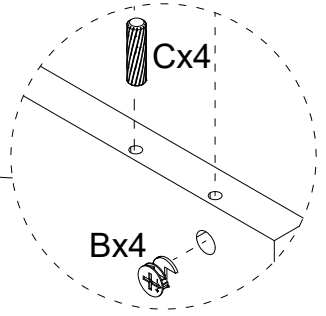

4

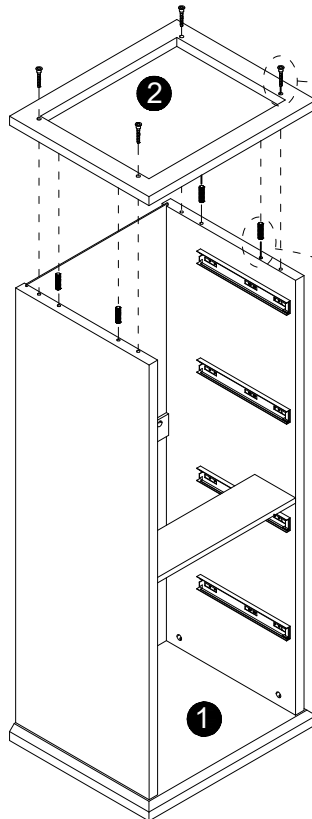
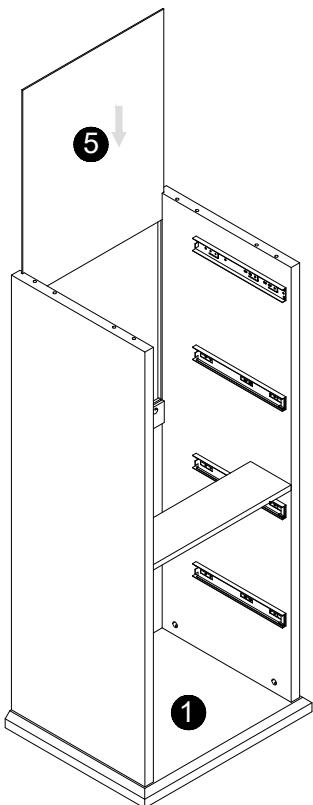

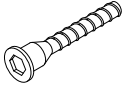
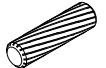
G	D	C
		
4mm	Ø7x38mm	Ø8x30mm
1pc	4pcs	4pcs

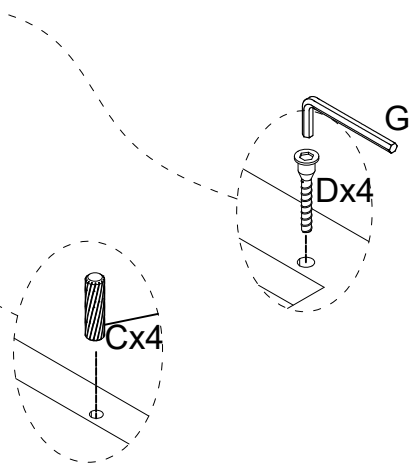

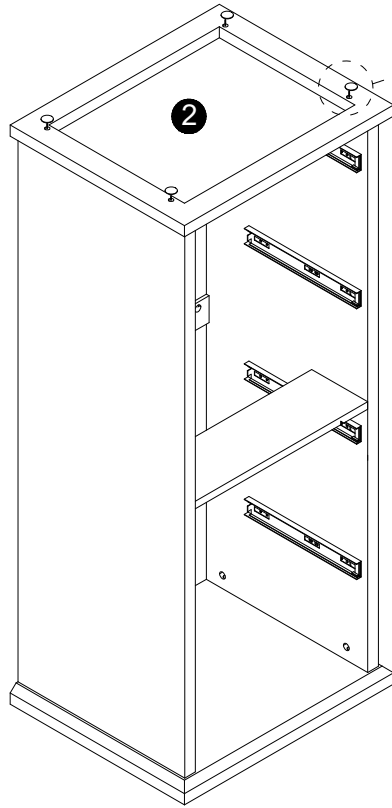

5

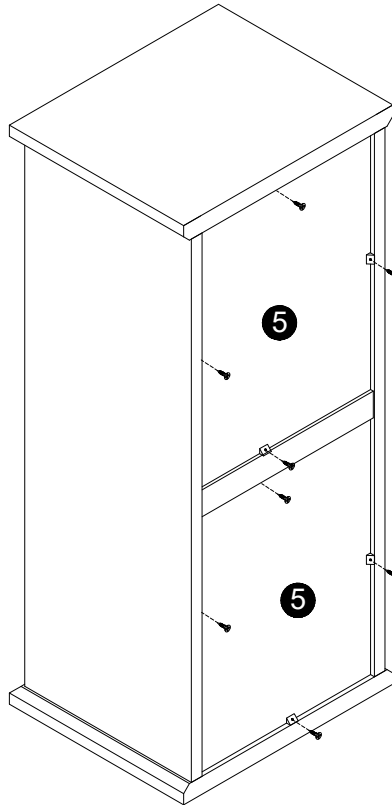

K

4pcs

6

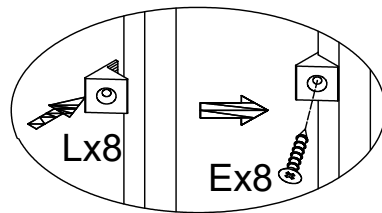

E	L
 Ø3.5x14mm	
8pcs	8pcs



7

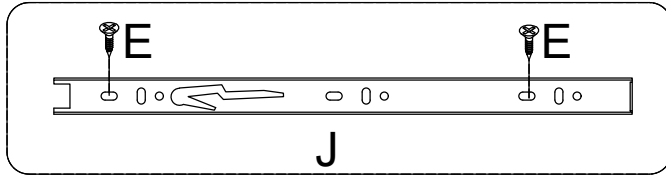

J	A	E
290mm	Ø6x35mm	Ø3.5x14mm
8pcs	16pcs	28pcs

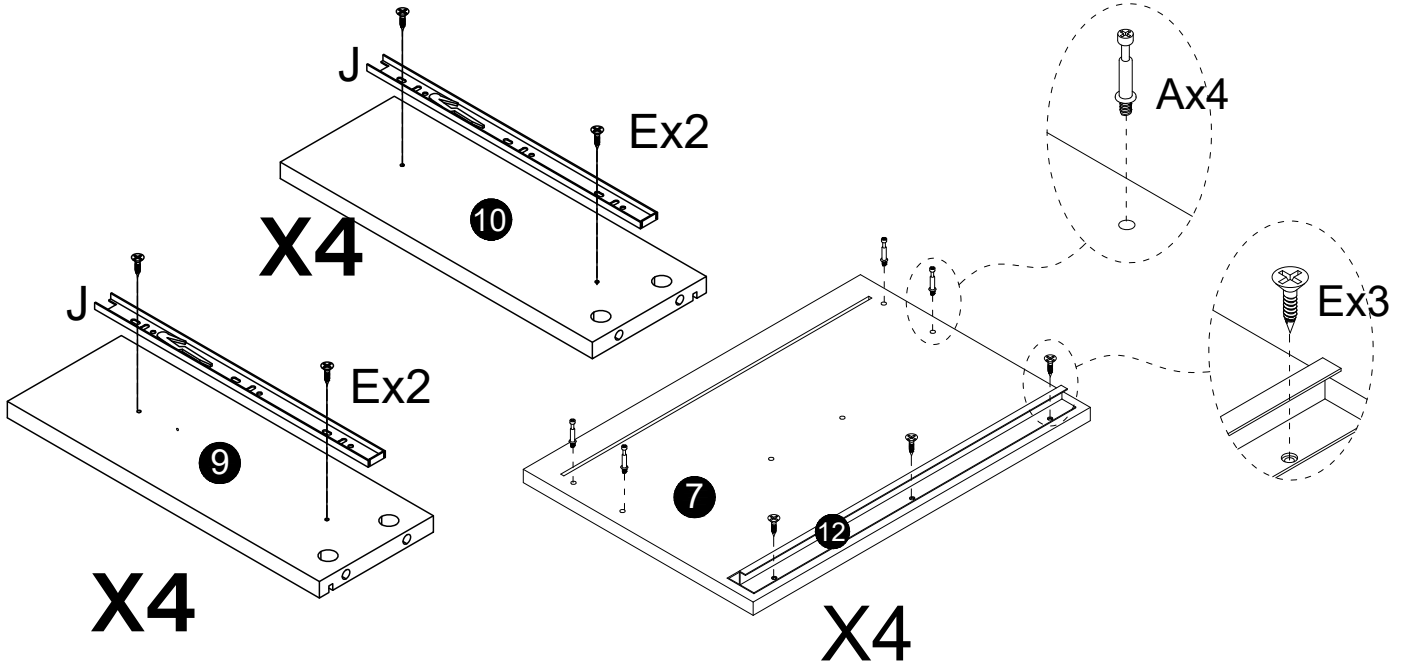

8

G	D
4mm	Ø7x38mm
1pc	16pcs

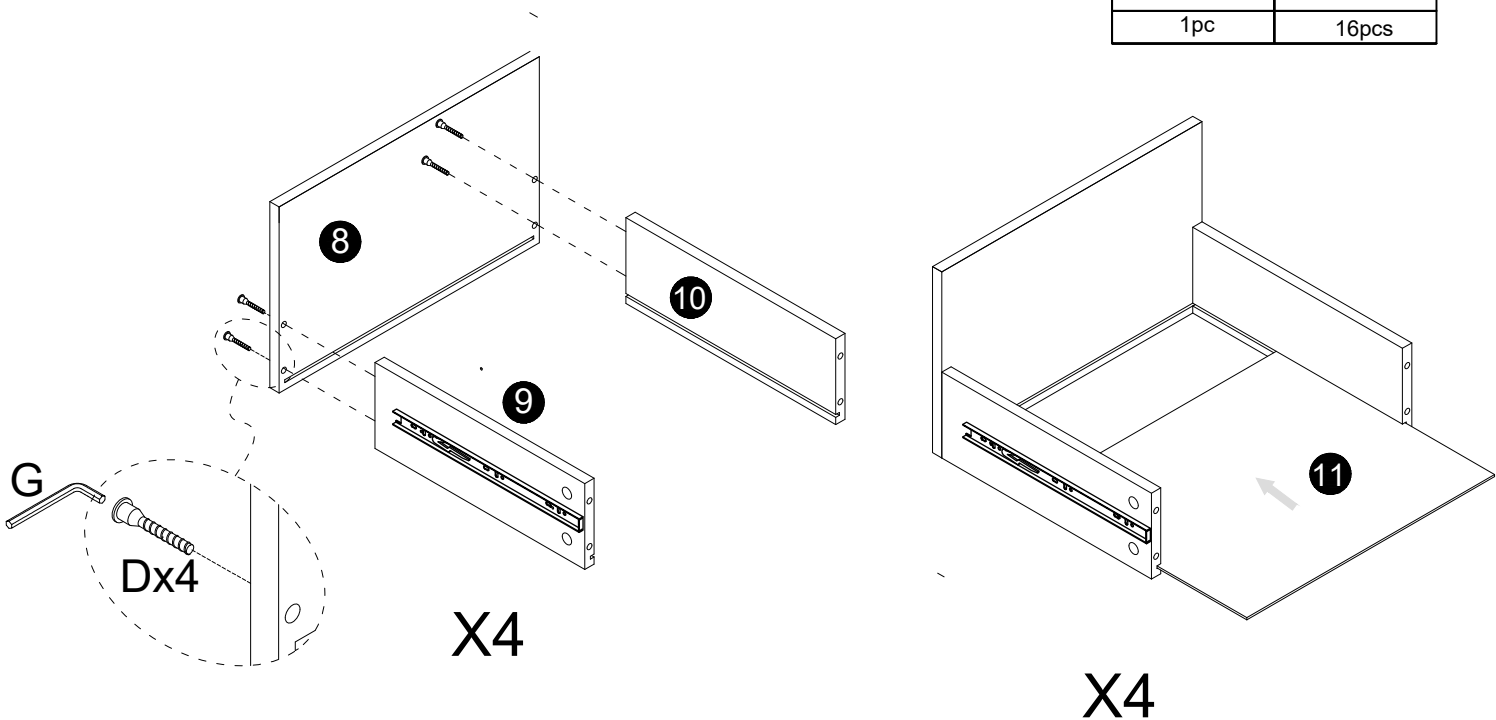

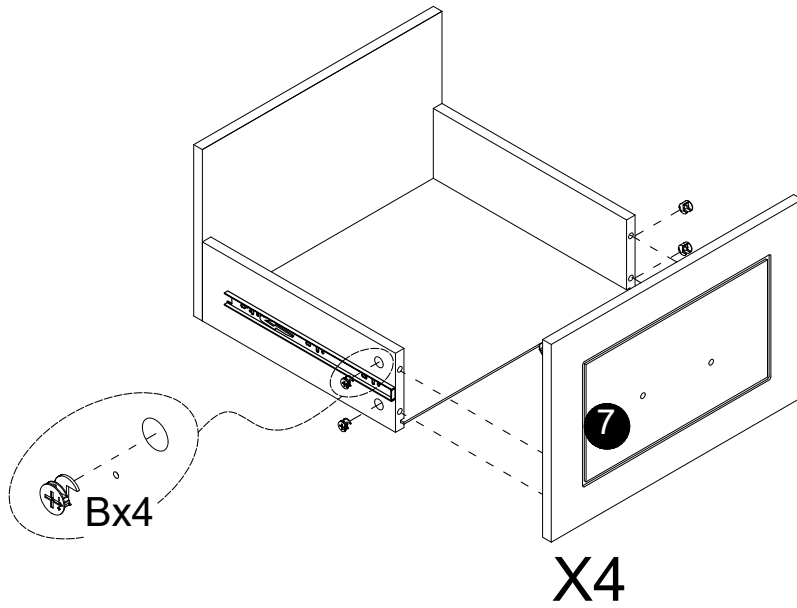

9

B

Ø15x12mm
16pcs

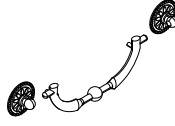

10

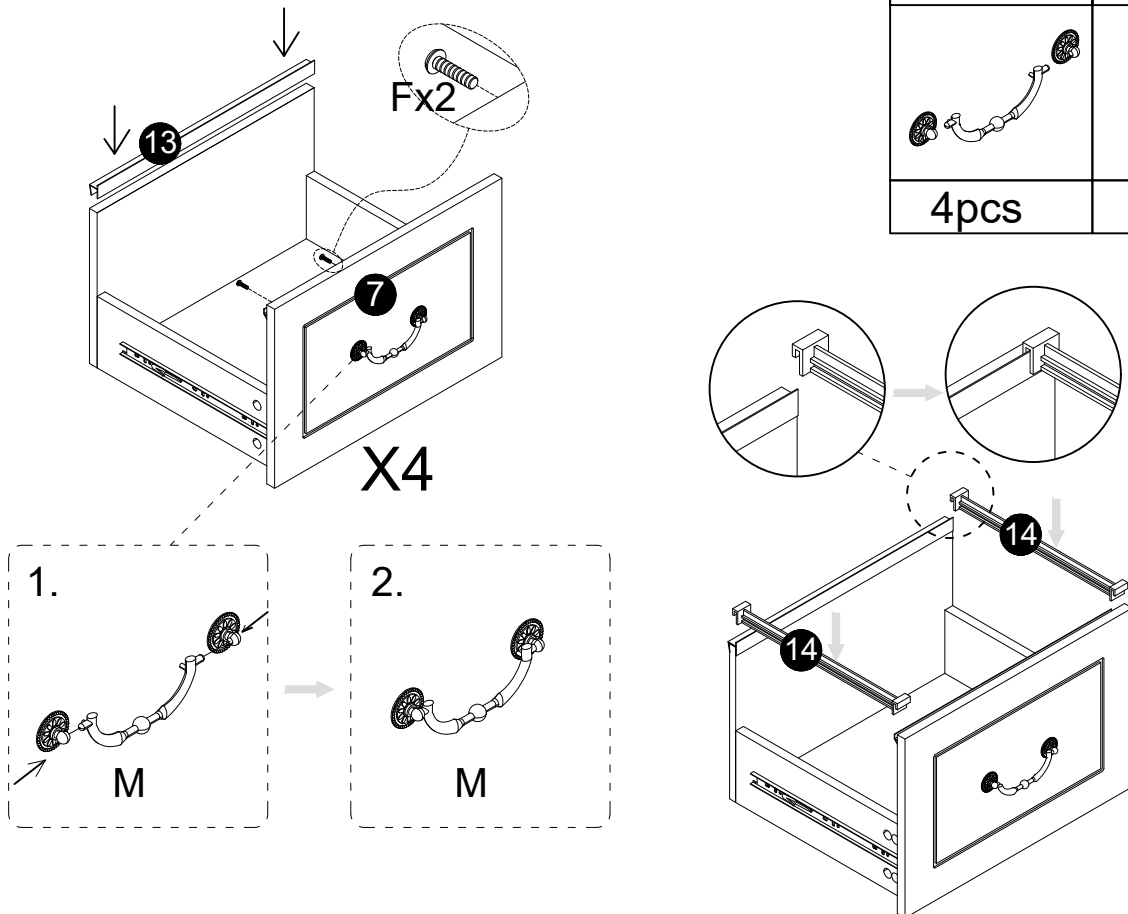
M	F
	
4pcs	M4x22mm
8pcs	

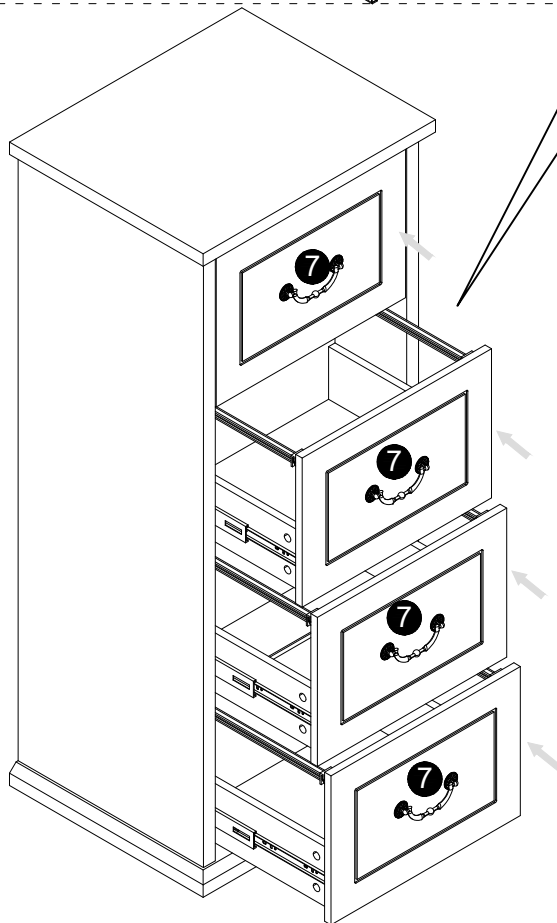
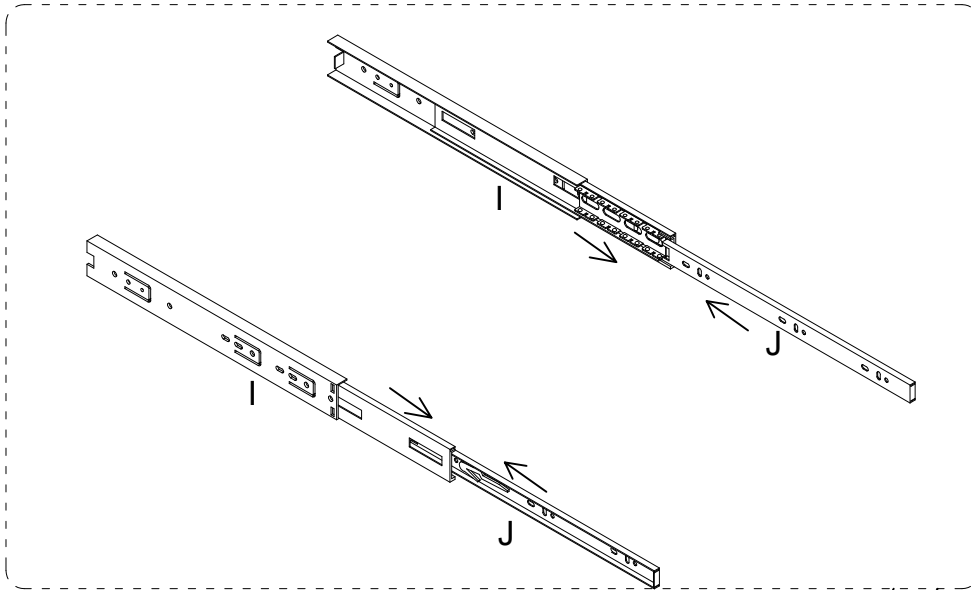



12

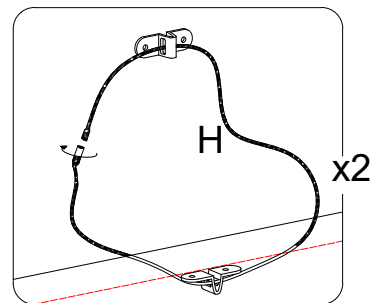
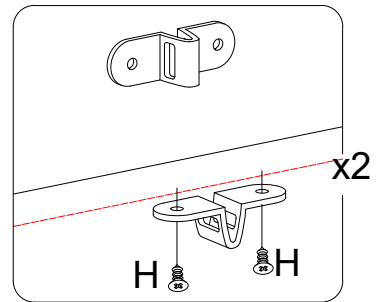
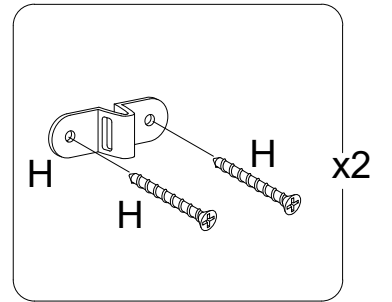
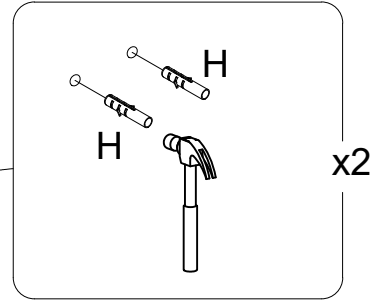
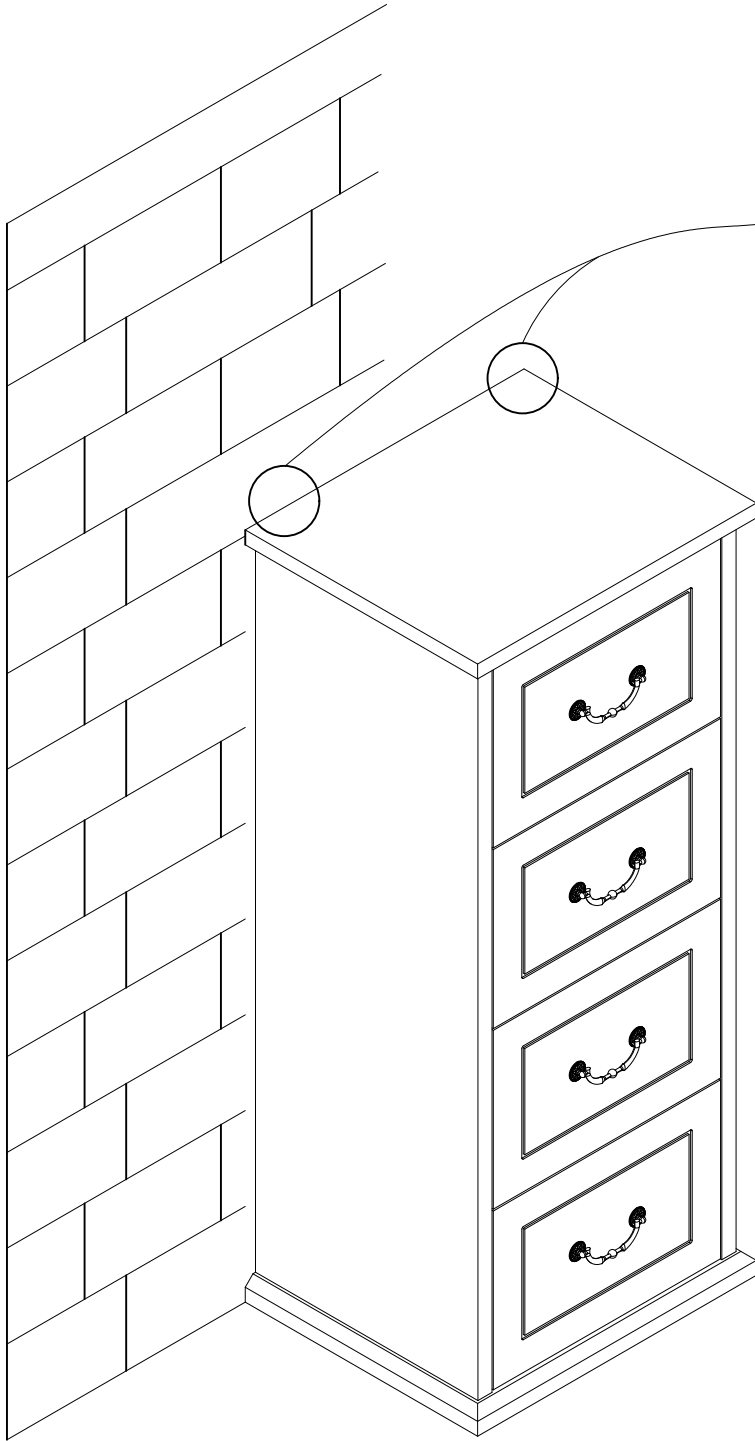
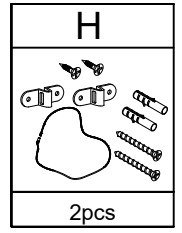

Thank you for your support!

