

ASSEMBLY INSTRUCTIONS

INSTRUCTIONS DE MONTAGE

TWIN PLATFORM BED

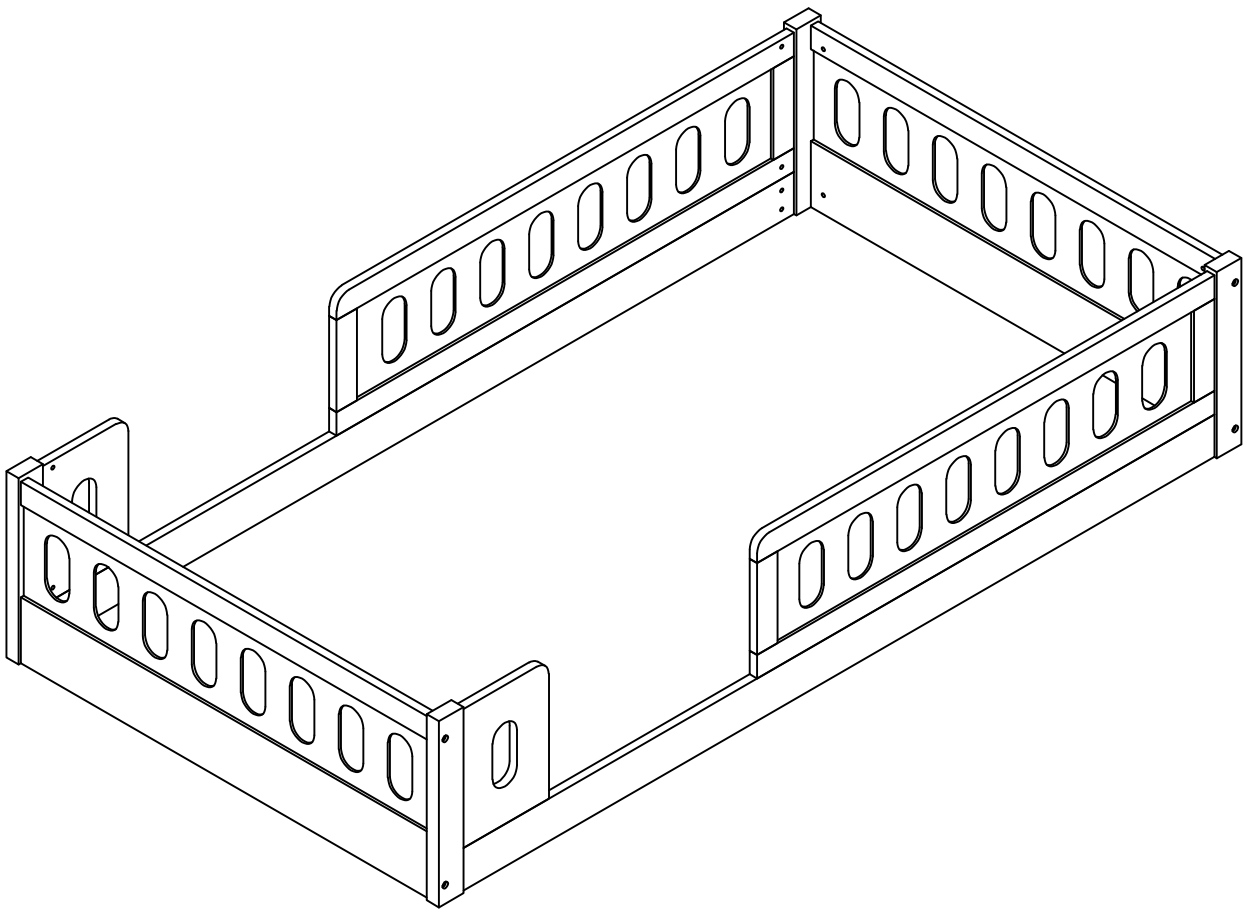



LIT PLATEFORME DOUBLE

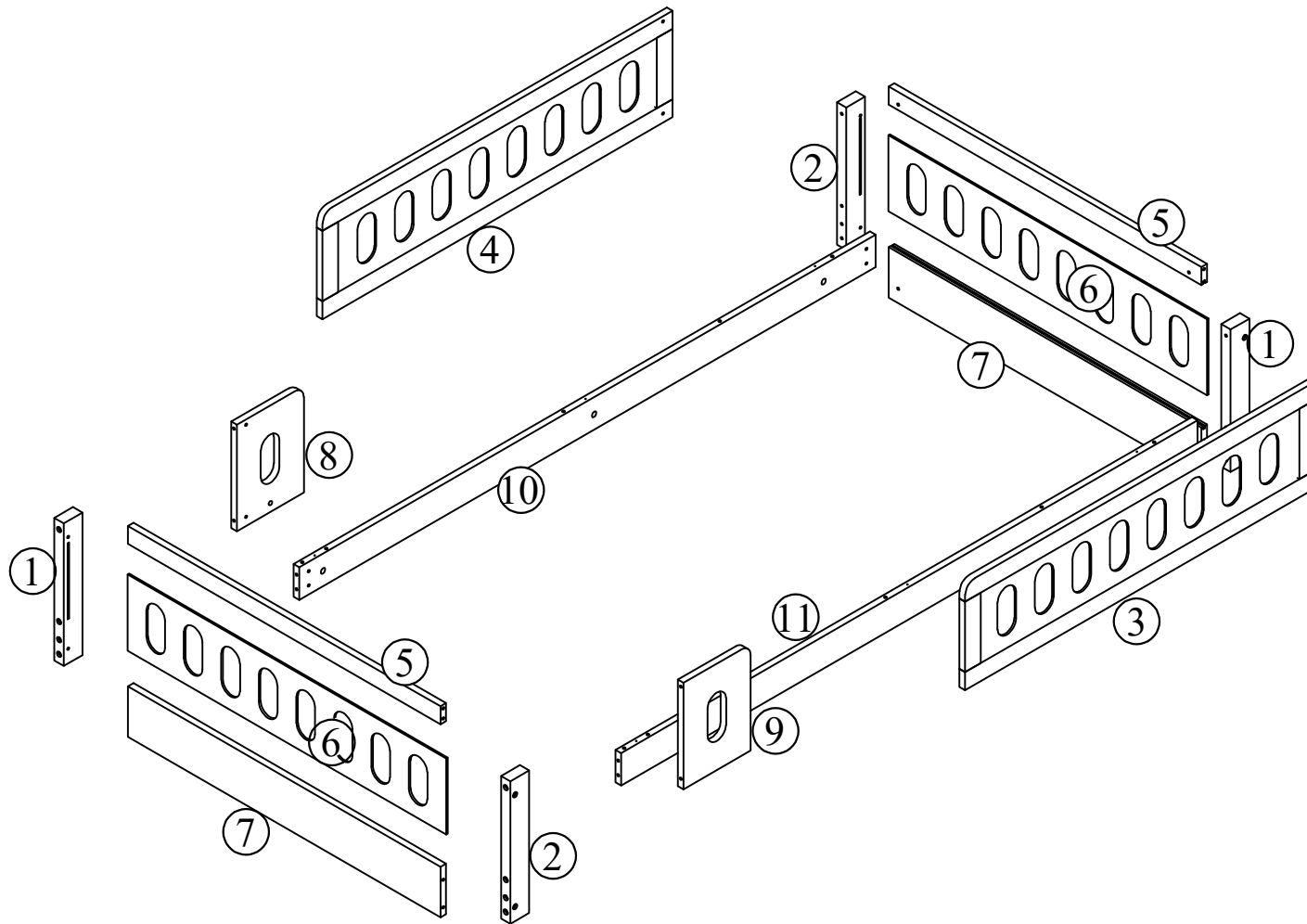





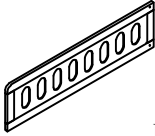
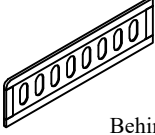
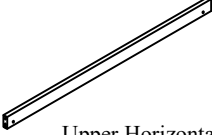
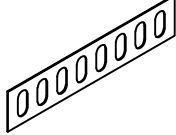
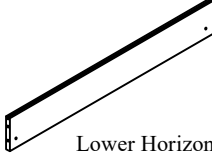

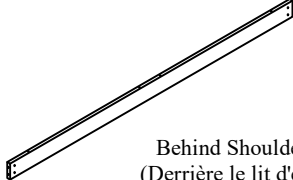
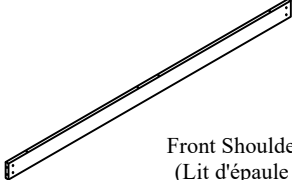
Detail View
(vue détaillée)



Part List : (Liste des pièces)

1  Left Legs -2pcs (La jambe gauche -2pcs)	2  Right Legs -2pcs (Jambes droites -2pcs)	3  Front Panel -1pc (Panneau avant -1pc)
4  Behind Panel -1pc (Derrière le panneau -1pc)	5  Upper Horizontal Bar-2pcs (Barre horizontale supérieure-2pcs)	6  Panel-2pcs (Panneau-2pcs)
7  Lower Horizontal Bar-2pcs (Barre horizontale inférieure-2pcs)	8  Behind Bar-1pc (Derrière le bar-1pc)	9  Front Bar-1pc (Barre avant-1pc)
10  Behind Shoulder Bed -1pc (Derrière le lit d'épaule-1pc)	11  Front Shoulder Bed -1pc (Lit d'épaule avant-1pc)	

Hardware List (Liste du matériel)

A  Ø1/4" x 100mm Bolts = 16pcs (Boulons = 16pcs)	B  Ø1/4" x 60mm Bolts = 8pcs (Boulons = 8pcs)	C  Ø1/4" x Ø10 x 12mm Cross nut =24pcs Écrou transversal=24pcs
D  Ø8 x 30mm Wood dowel =18pcs (Cheville en bois=18pcs)	E  K4mm Allen key (1pc) clé Allen (1pc)	F  Ø8*33 Ø15x10 Cam locks =6pcs (Serrures à came =6pcs)

ASSEMBLY TOOLS REQUIRED (NOT INCLUDED) OUTILS D'ASSEMBLAGE REQUIS (NON INCLUS)

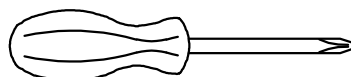

**PLEASE BE CAREFUL DO NOT DAMAGE THE HOLE POSITION WHEN YOU USE POWER TOOLS !
(FAITES ATTENTION À NE PAS ENDOMMAGER LA POSITION DU TROU LORSQUE VOUS UTILISEZ DES OUTILS ÉLECTRIQUES !)**

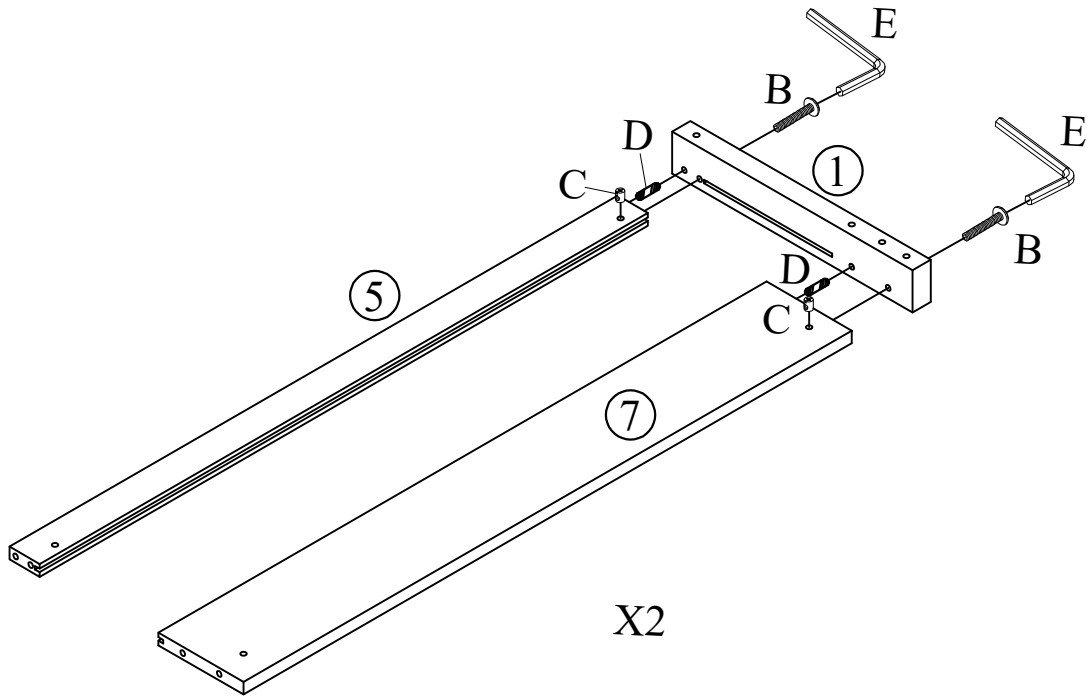
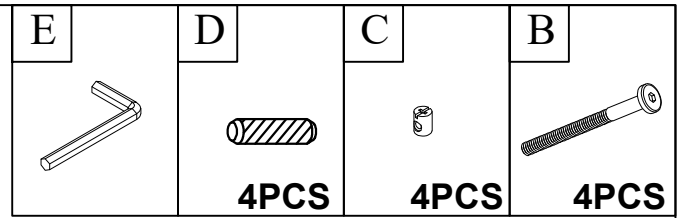

STEP 1:
(ÉTAPE 1)

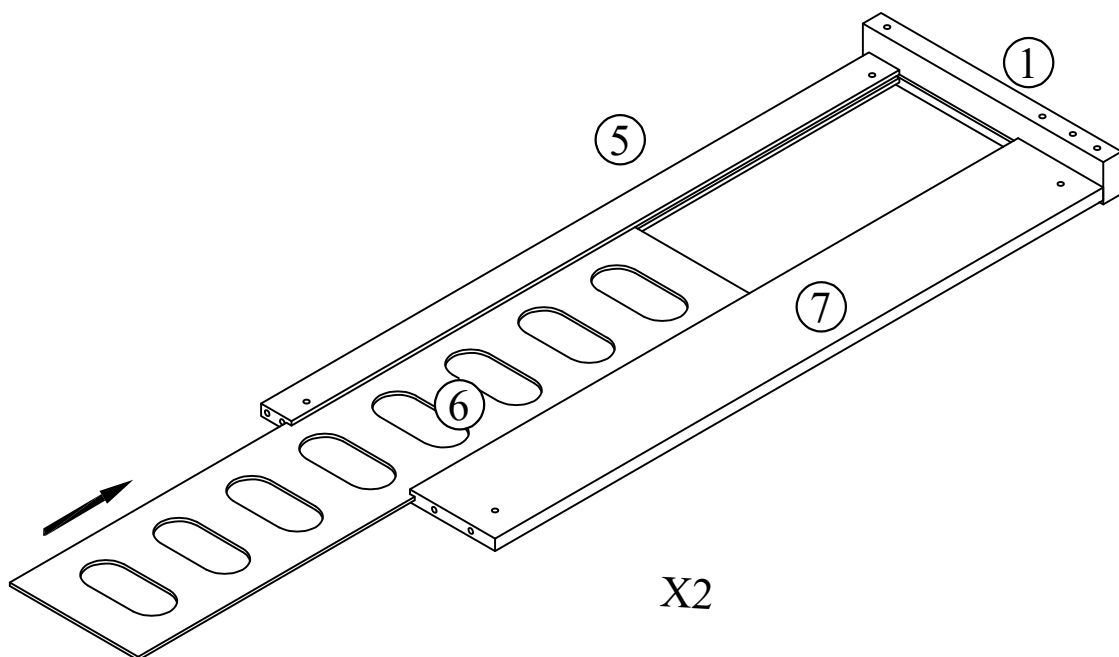

STEP 2:
(ÉTAPE 2)



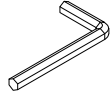

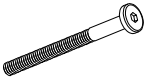
STEP 3:
(ÉTAPE 3)

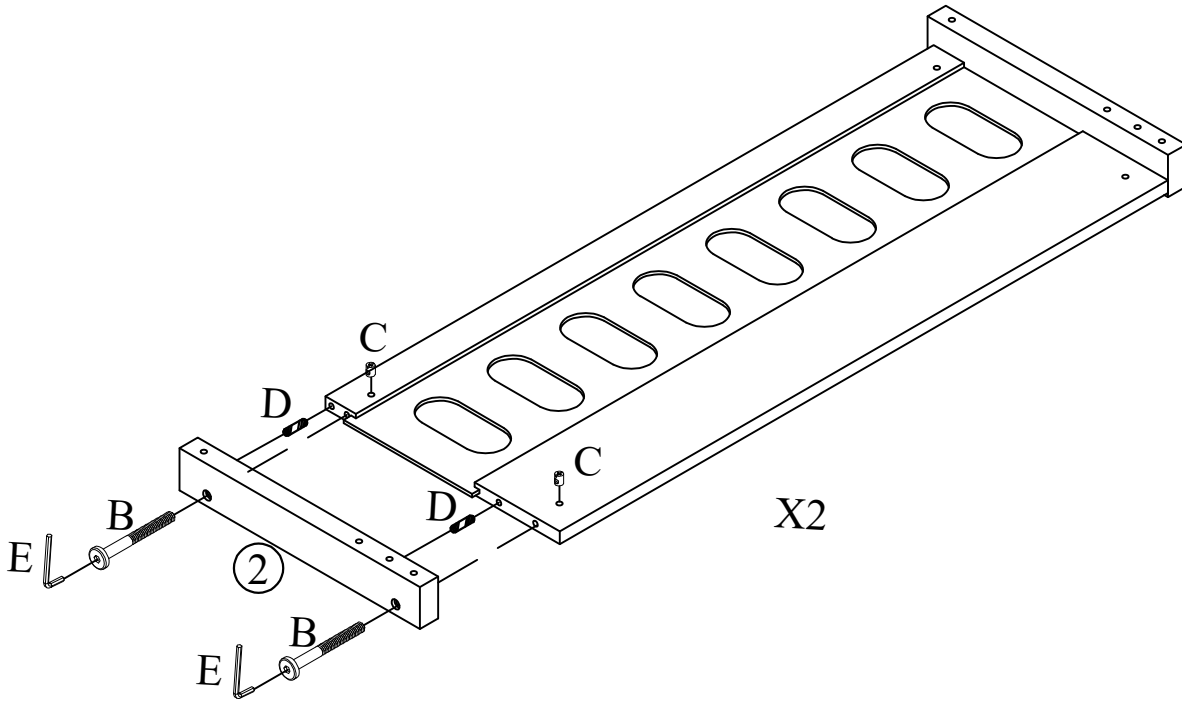
<p>E</p> 	<p>D</p>  <p>4PCS</p>	<p>C</p>  <p>4PCS</p>	<p>B</p>  <p>4PCS</p>
--	--	--	--



STEP 4:
(ÉTAPE 4)

<p>F</p>   <p>3PCS</p>	<p>D</p>  <p>5PCS</p>
--	--

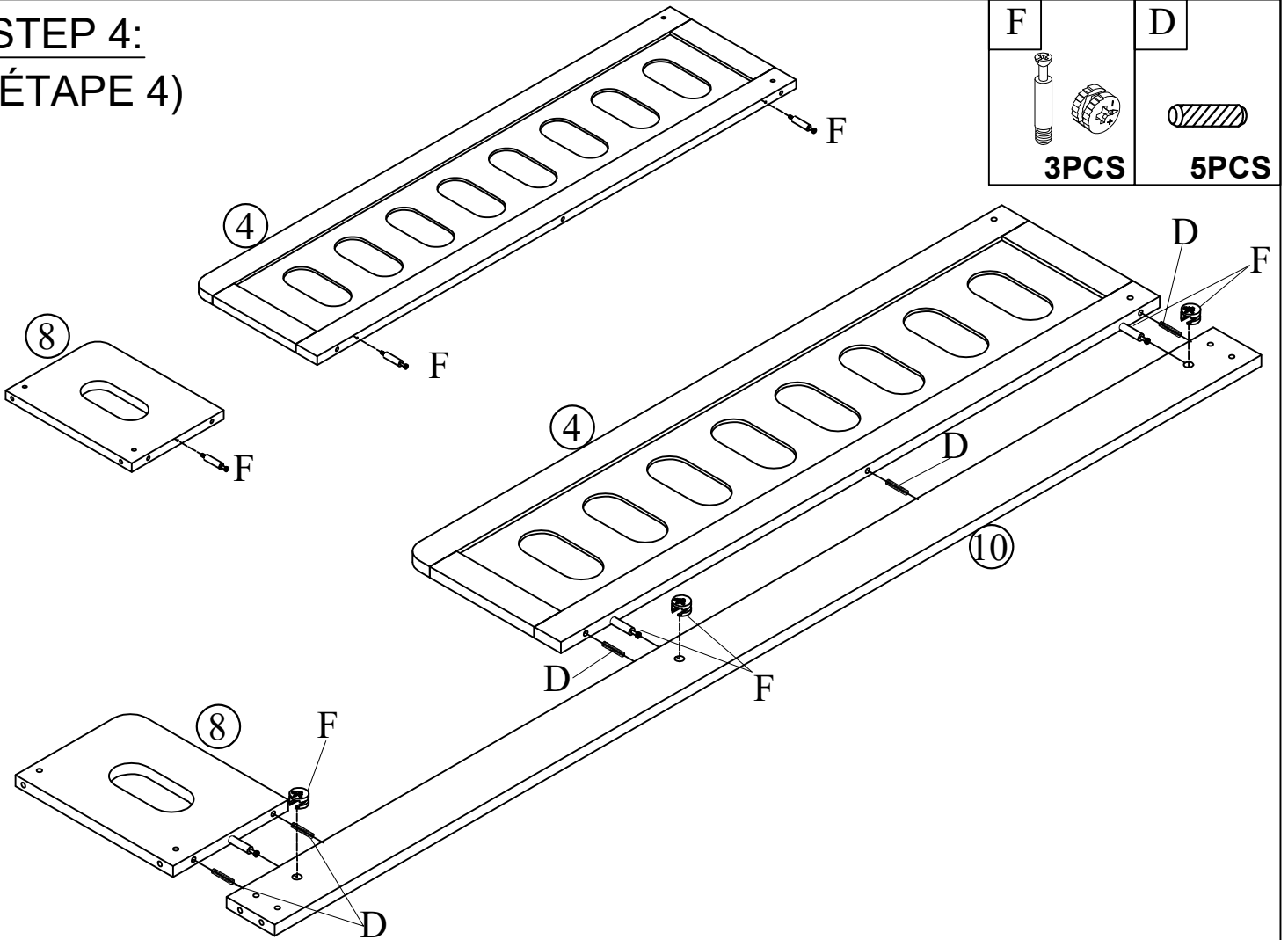

STEP 5:
(ÉTAPE 5)

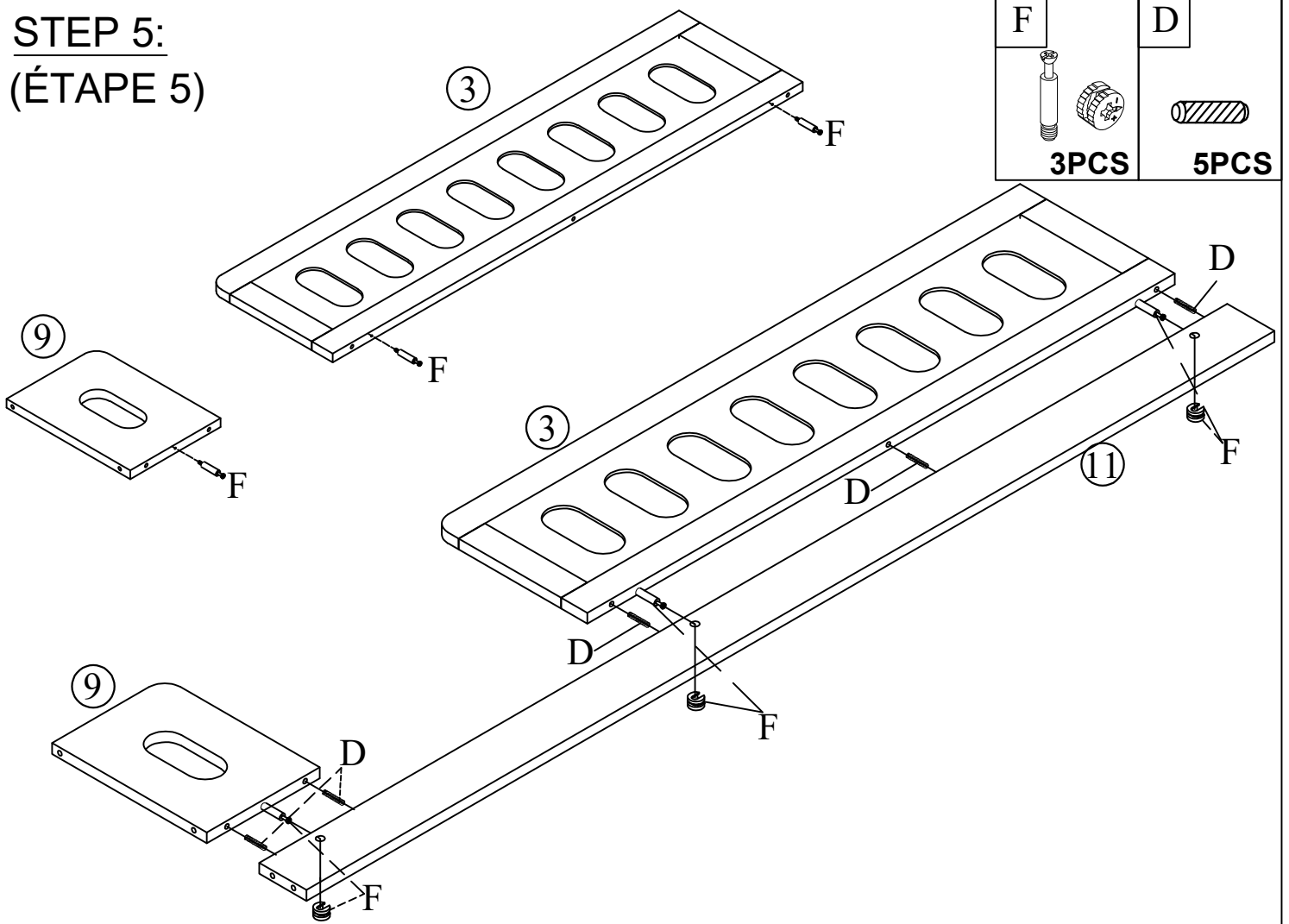

STEP 6:
(ÉTAPE 6)

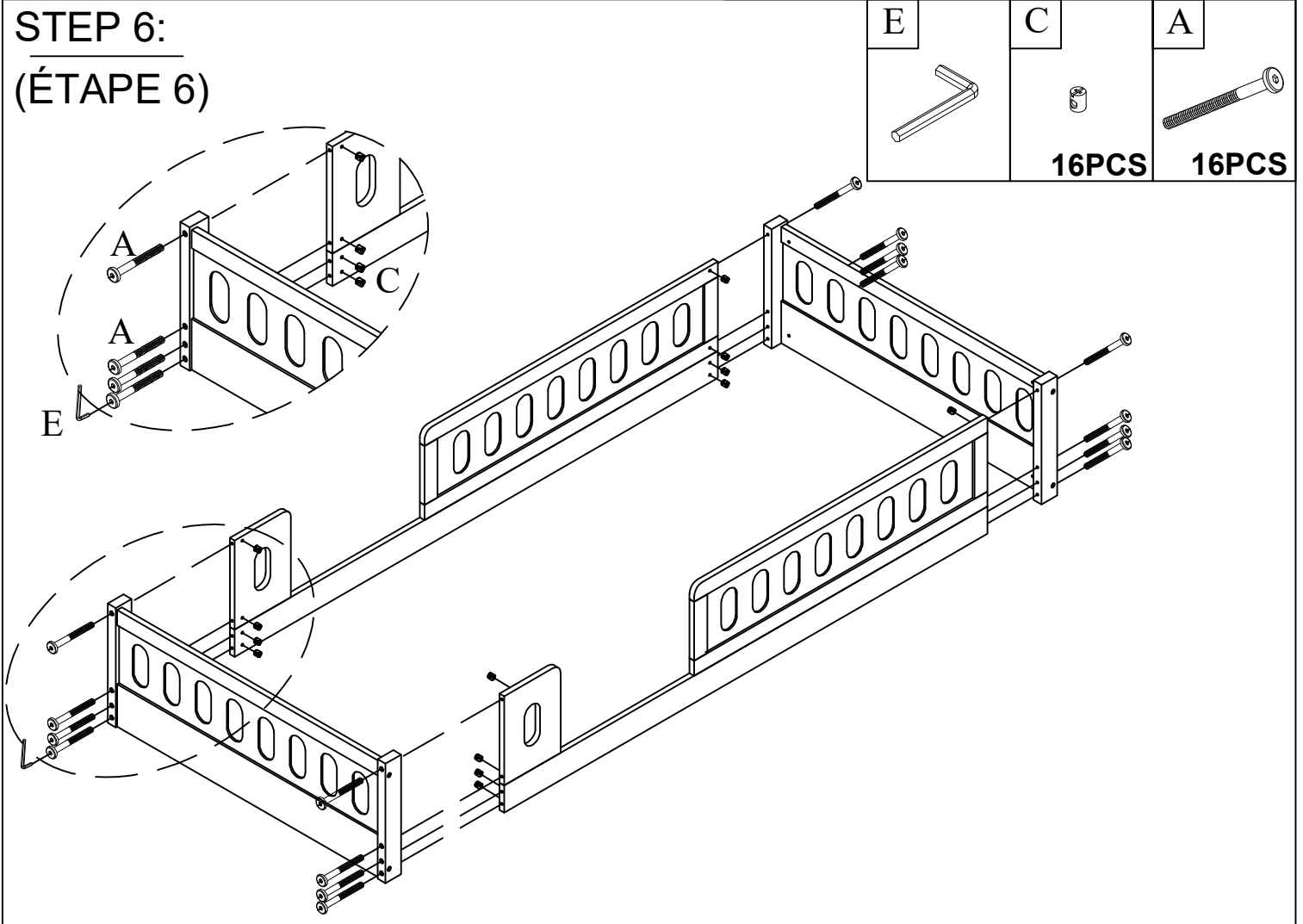

STEP 7:
(ÉTAPE 7)

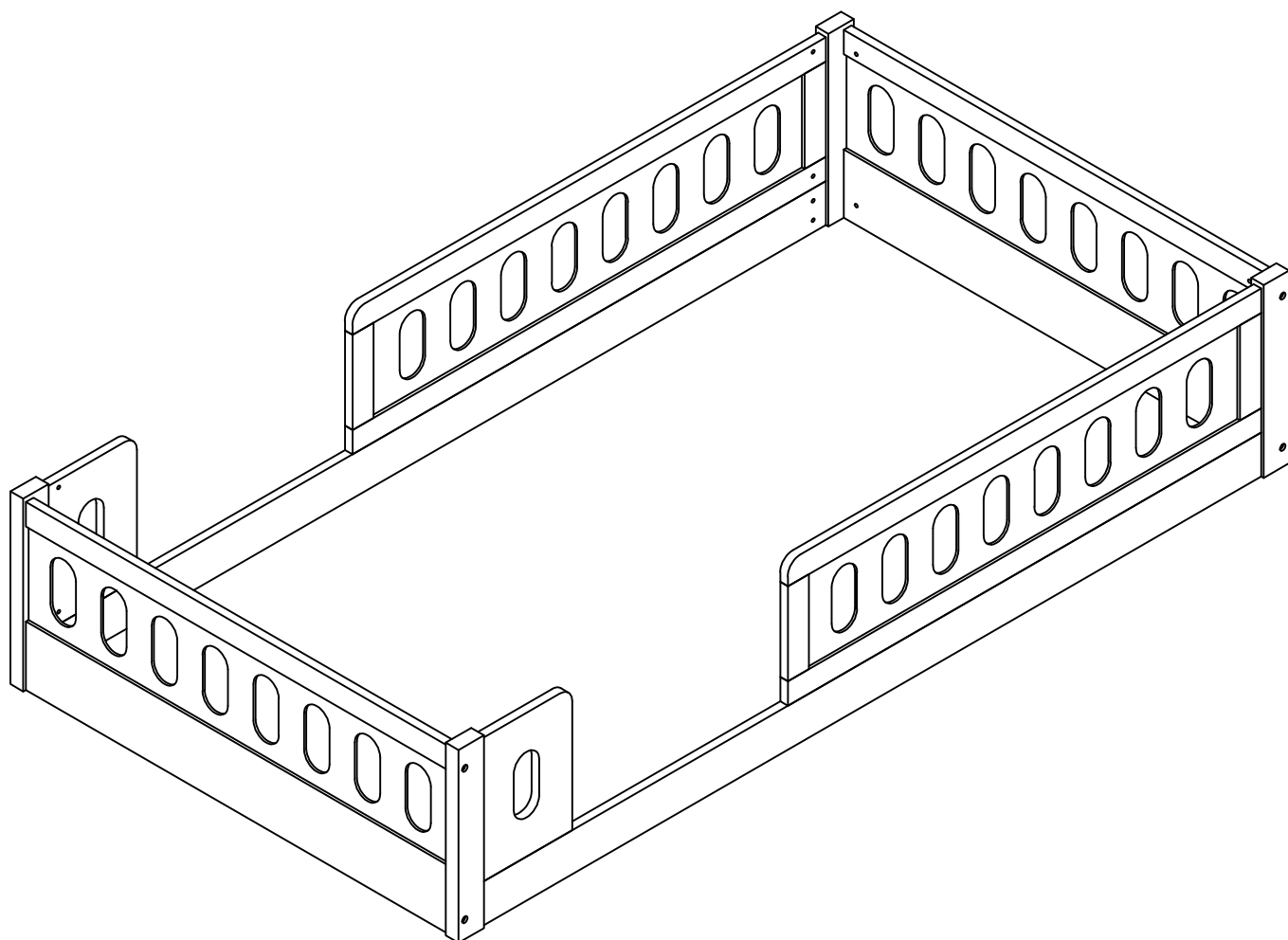

Assembly is Completed
(L'assemblage est terminé)