



ASSEMBLY INSTRUCTIONS

Read this instruction carefully. See hardware and furniture part list for guidance. Be sure all parts are complete, before you assemble. Place all wooden furniture parts on a clean and flat soft surface to prevent from being scratched. Follow the figure to start assembling.

CAUTIONS : 1. Do not FULLY - TIGHTEN the nut or nut bolt until all nut or bolt is ready assembled.
 2. Do not OVER - TIGHTEN the nut or bolt to avoid causing damages to the thread.
 3. Keep all hardware parts out of reach of children.

NOTE : 1. THE LIST AND QUANTITY SHOWN ARE FOR 1 UNIT ASSEMBLY
 2. EXTRA M4 ALLEN KEY WERE PROVIDED TO USE FOR TIGHTEN ALL HINGES OF PART C, D AND E

PART LIST		
ITEM	DESCRIPTION	QTY
A	CUSHION BACK	1 PC
B	CUSHION SEAT	3 PCS
C	BOX SEAT	1 PC
D	ARM (L)	1 PC
E	ARM (R)	1 PC
F	LEG	4 PCS

HARDWARE LIST		
ITEM	DESCRIPTION	QTY
1	JCBB Bolt M8 x 70mm 	4pcs
2	M5 ALLEN KEY (BALL SHAPE) 	1pc
3	M4 ALLEN KEY (BALL SHAPE) 	1pc

STEP 1

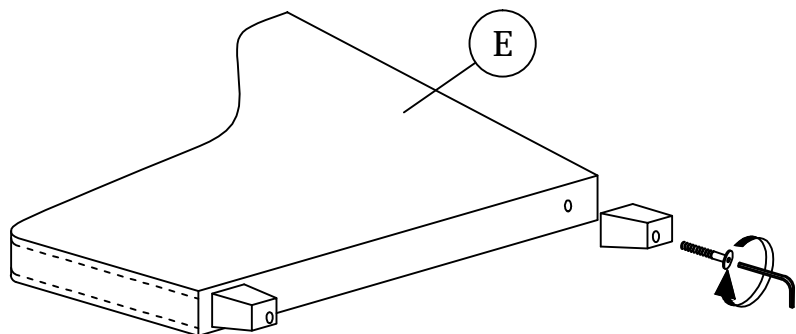
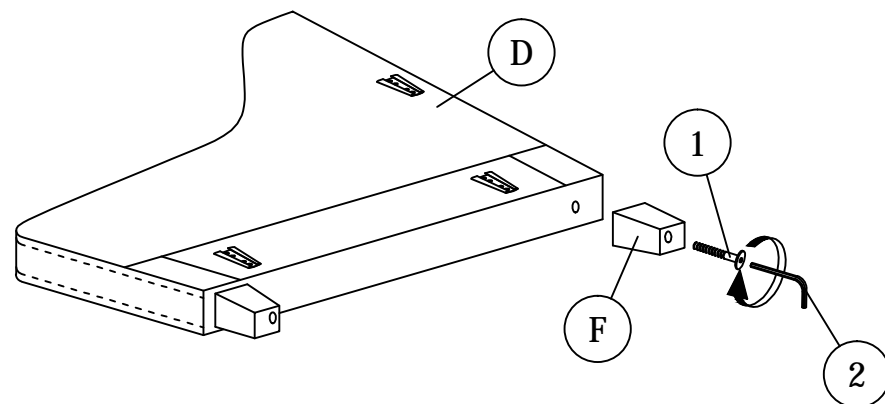

STEP 2

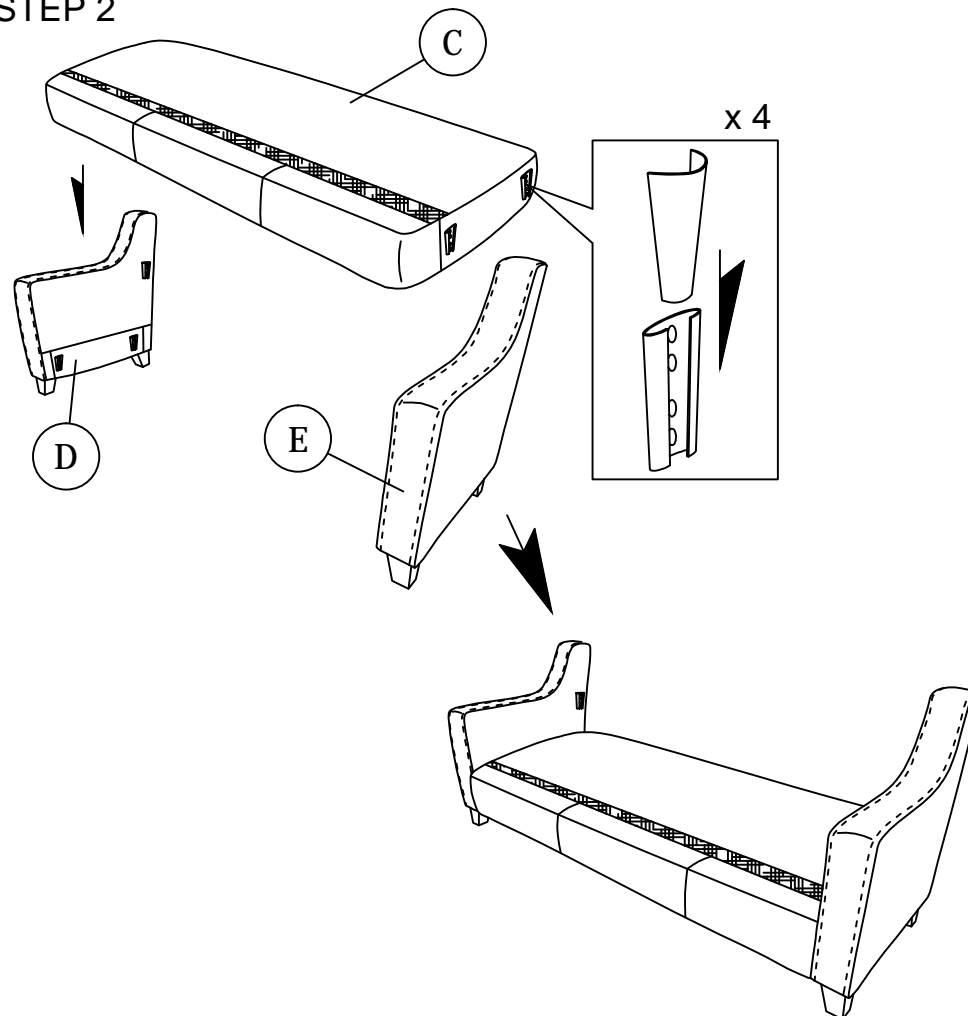

ASSEMBLY INSTRUCTIONS

STEP 3

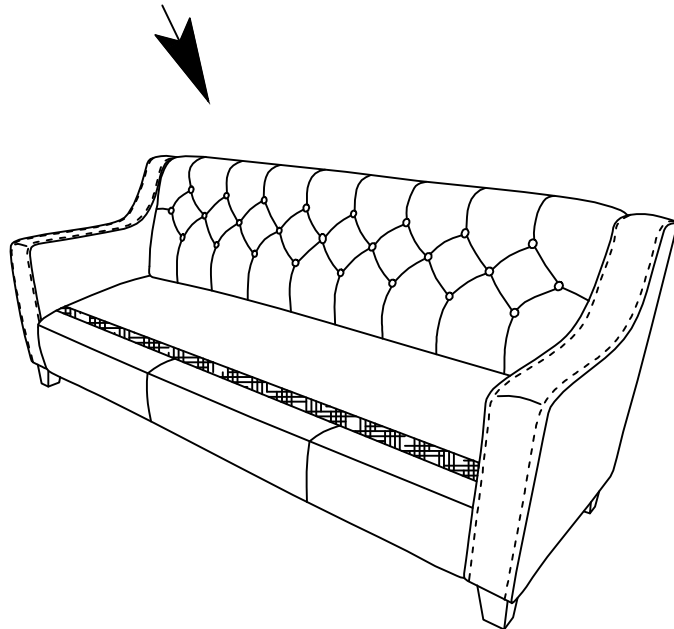
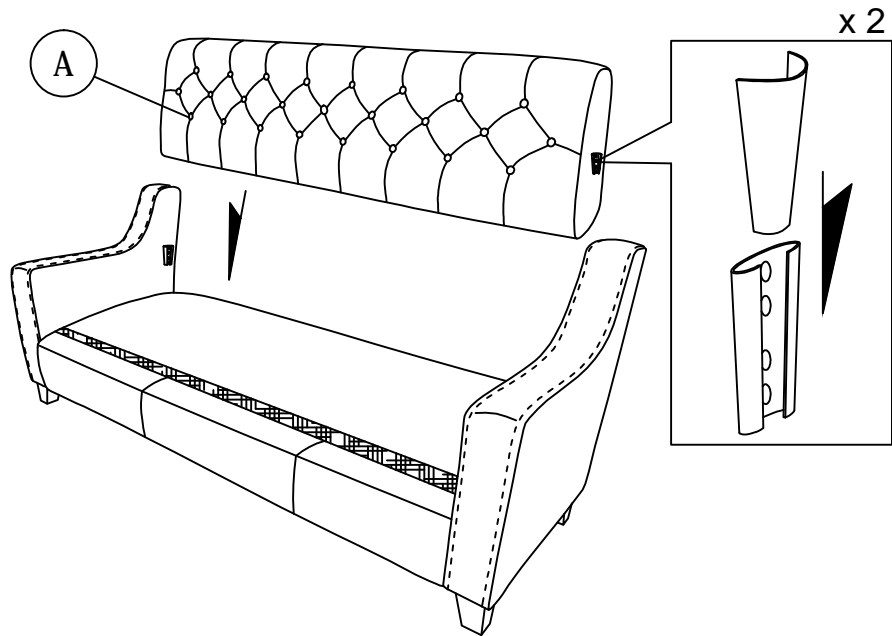

STEP 4

