

INSTRUCTIONS  
INSTRUCTION  
ANWEISUNG

사용설명서  
取扱説明書

LSTRUZIONI PER L'INSTALLAZIONE  
LIBRO DE INSTRUCCIONES



Product Name: Dog cage  
Country of origin: Made in China

Please install according to the instructions  
Bitte gemäß den Anweisungen installieren  
Veuillez installer selon les notices  
Installare secondo le istruzioni  
Seguir las instrucciones del manual para la  
instalación del producto  
説明書に従って取り付けてください  
설명서에 따라 설치하세요.

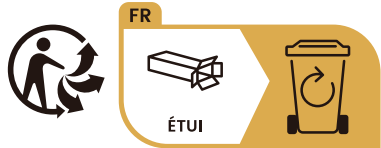

FR

Ce meuble se recycle,  
s'il n'est plus utilisable  
déposez-le en déchèterie.  
Notice à trier.



A\*2

HINTERTÜR  
背板  
PORTE ARRIÈRE  
BACK STEEL PANEL  
후문  
Pannello posteriore  
Panel trasero

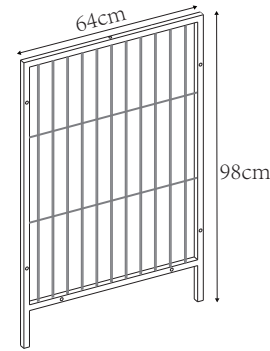

B\*4

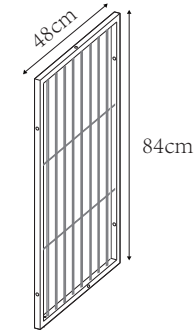

C\*2

UNTERE TÜR  
底板  
PORTE DU BAS  
BOTTOM PANEL  
밑판  
Pannello inferiore  
Panel inferior

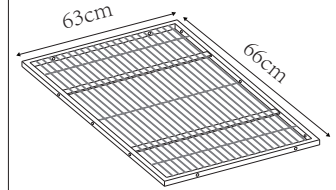

D\*1

HAUSTÜR 1  
ドア 1  
PORTE D'ENTRÉE 1  
FRONT DOOR 1  
정문 1  
Porta anteriore 1  
Puerta frontal 1

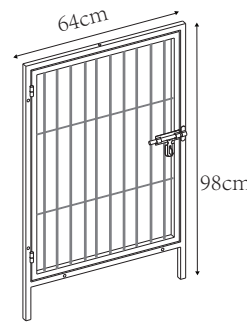

E\*1

HAUSTÜR 2  
ドア 2  
PORTE D'ENTRÉE 2  
FRONT DOOR 2  
정문 2  
Porta anteriore 2  
Puerta frontal 2

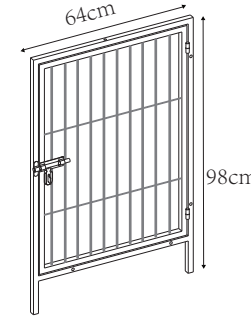

F\*2

OBERE TÜR  
天板  
PORTE DU HAUT  
TOP PANEL  
정수리  
Pannello superiore  
Panel superior

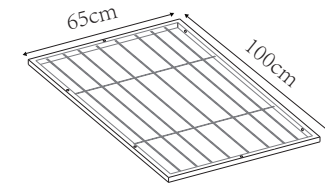

G\*2

TRENNTÜR  
仕切り  
SÉPARATEUR  
DIVIDER  
격자문  
Pannello divisorio  
Panel divisorio

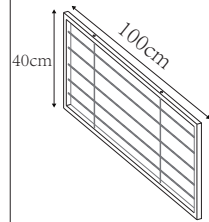

H\*2

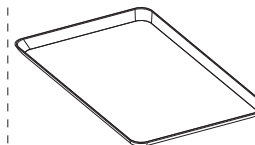

I\*2



J\*2



K\*48



M6 \*30mm

L\*40



M6 \*18mm

M\*8



M6

N\*1

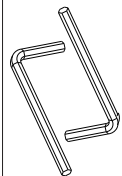

O\*1



1

1. 金網が外に向けてください、底板の金網が上に向けてください

1. 철망이 밖으로 향하십시오, 바닥판의 철망이 위로 향하세요

1. Bitte Installieren Sie das Drahtgeflecht nach au B en  
Bitte Installieren Sie das Drahtgeflecht der Bodenplatte nach oben

1. Install the metal wire mesh to the outward  
Install the bottom plate wire mesh upwards

1. Installez la grille métallique vers l'extérieur  
Installez la grille métallique de la plaque inférieure vers le haut

1. La rete metallica rivolta verso l'esterno, la rete metallica sul pavimento rivolta verso l'alto

1. La malla de alambre hacia afuera, la malla de alambre en el piso hacia arriba

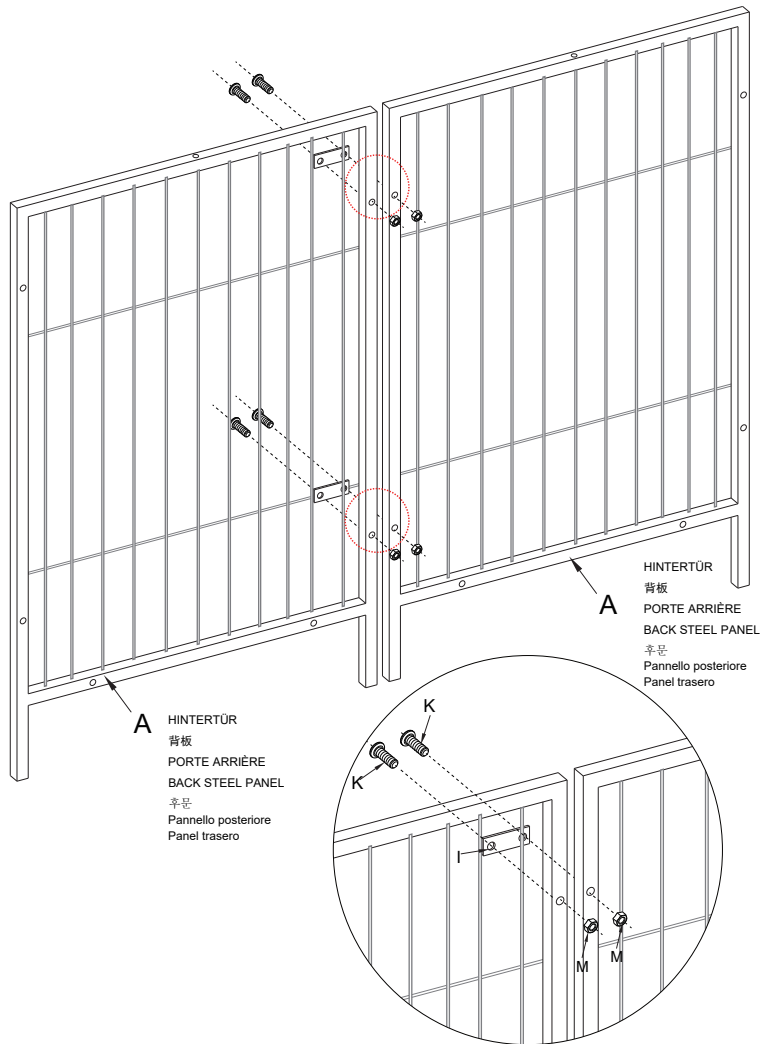
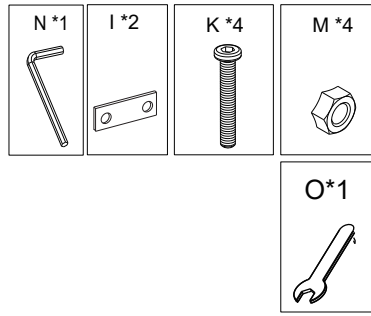

2

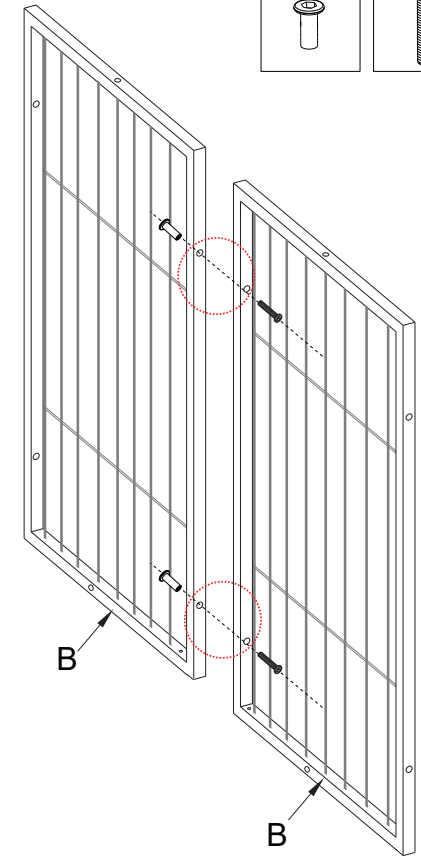
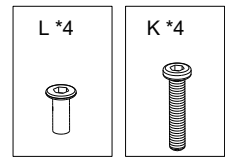
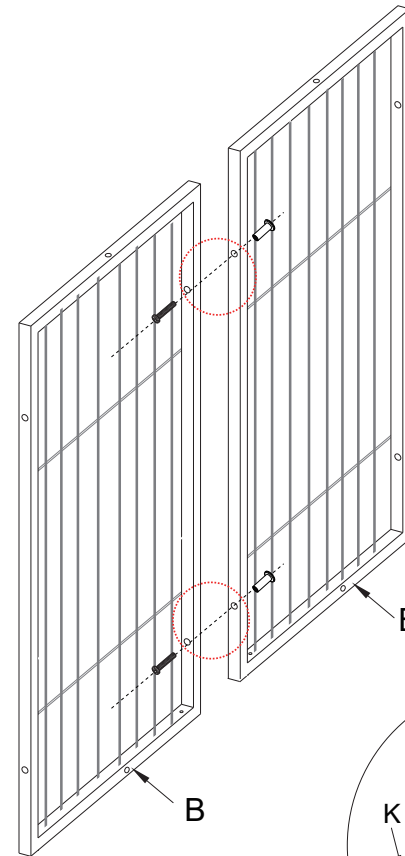
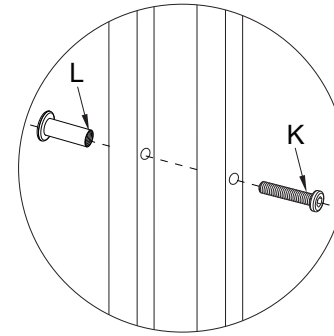

3

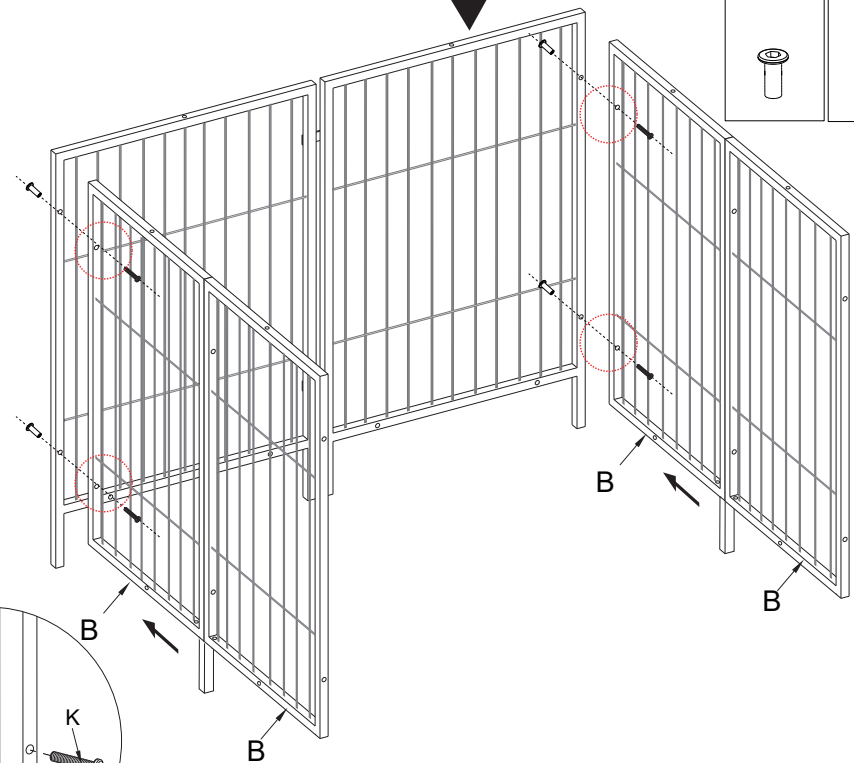
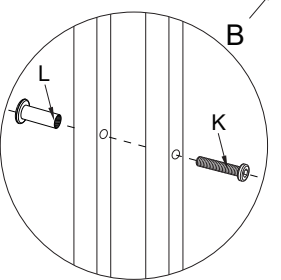
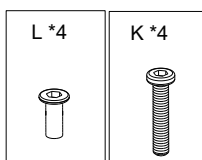
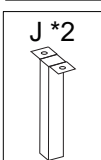
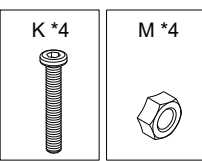
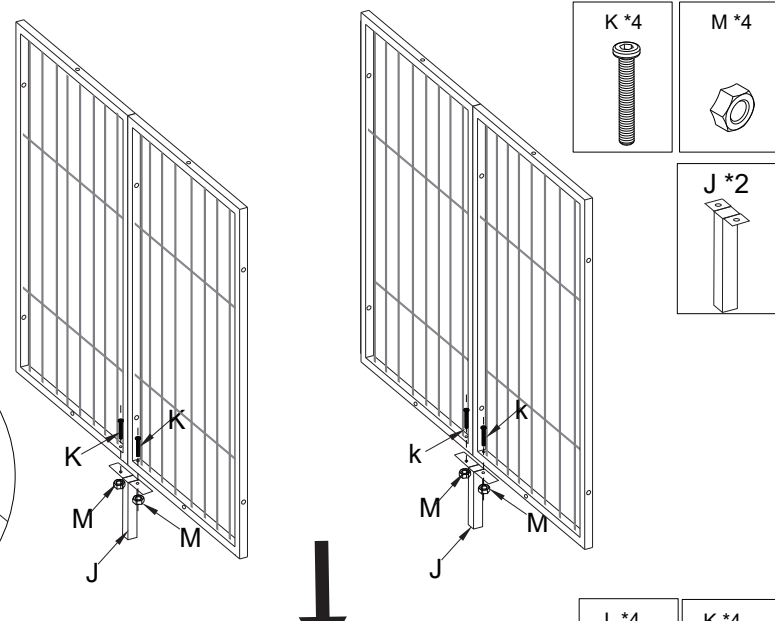
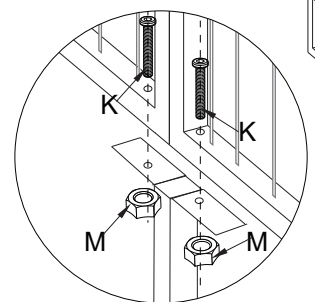

4

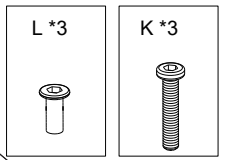
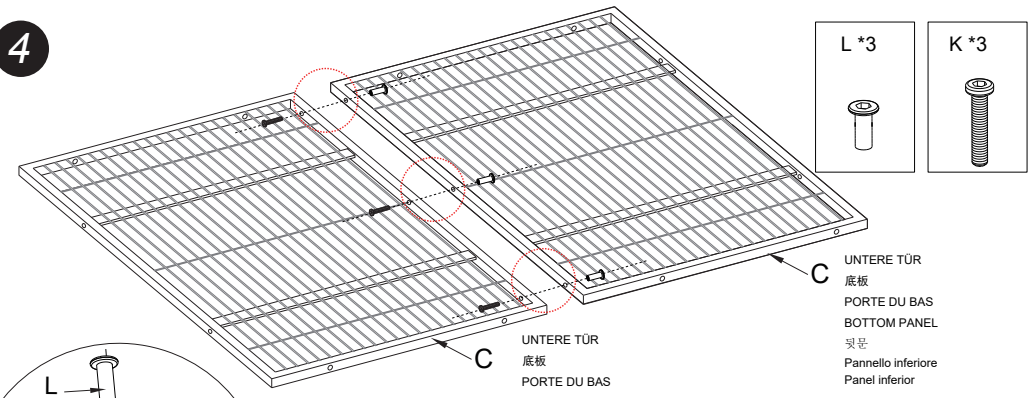
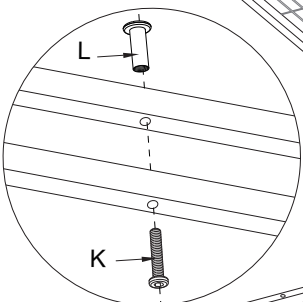

UNTERE TÜR  
 底板  
 PORTE DU BAS  
 BOTTOM PANEL  
 뒷문  
 Pannello inferiore  
 Panel inferior

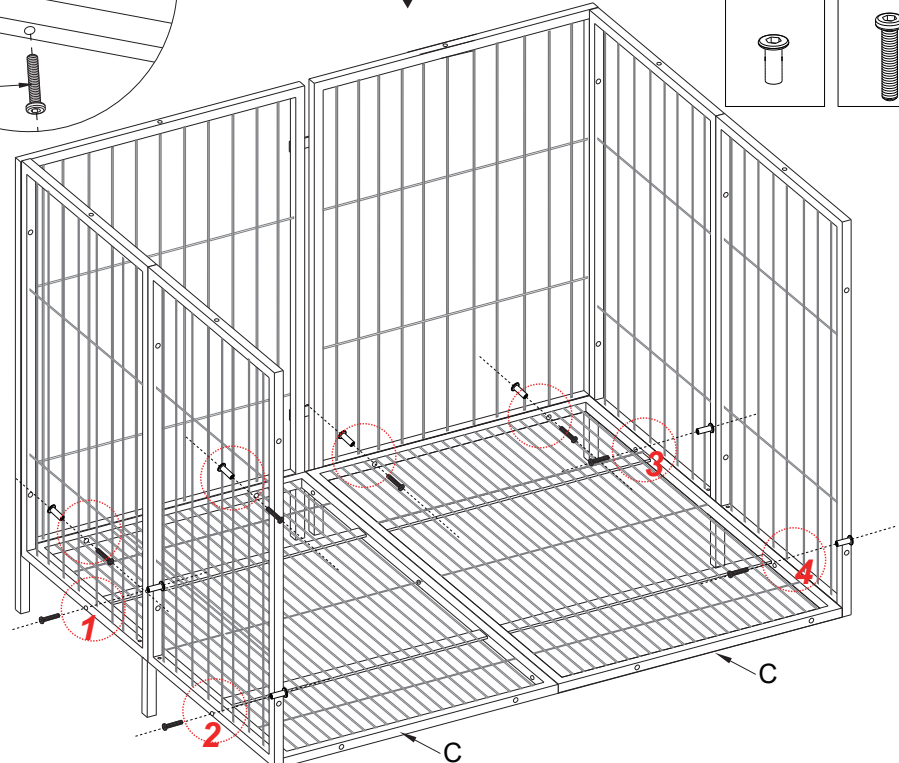
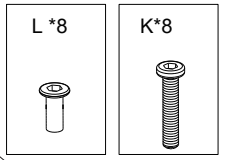

INSTALLIEREN SIE ZUERST DIE VIER ECKEN GEMÄß DER SERIENNUMMER  
 上図のように、1~4の順に板をそれぞれ取り付けてください  
 INSTALLEZ SELON LES ÉTAPES DU NUMÉRO  
 INSTALL THE SIDES FIRST ACCORDING TO THE NUMBERS  
 번호에 따라 네가지 모서리를 설치하십시오.  
 Come mostrato in figura, installare i pannelli secondo l'ordine ①-④  
 Como se muestra en la figura, instala los paneles en el orden ①-④

5

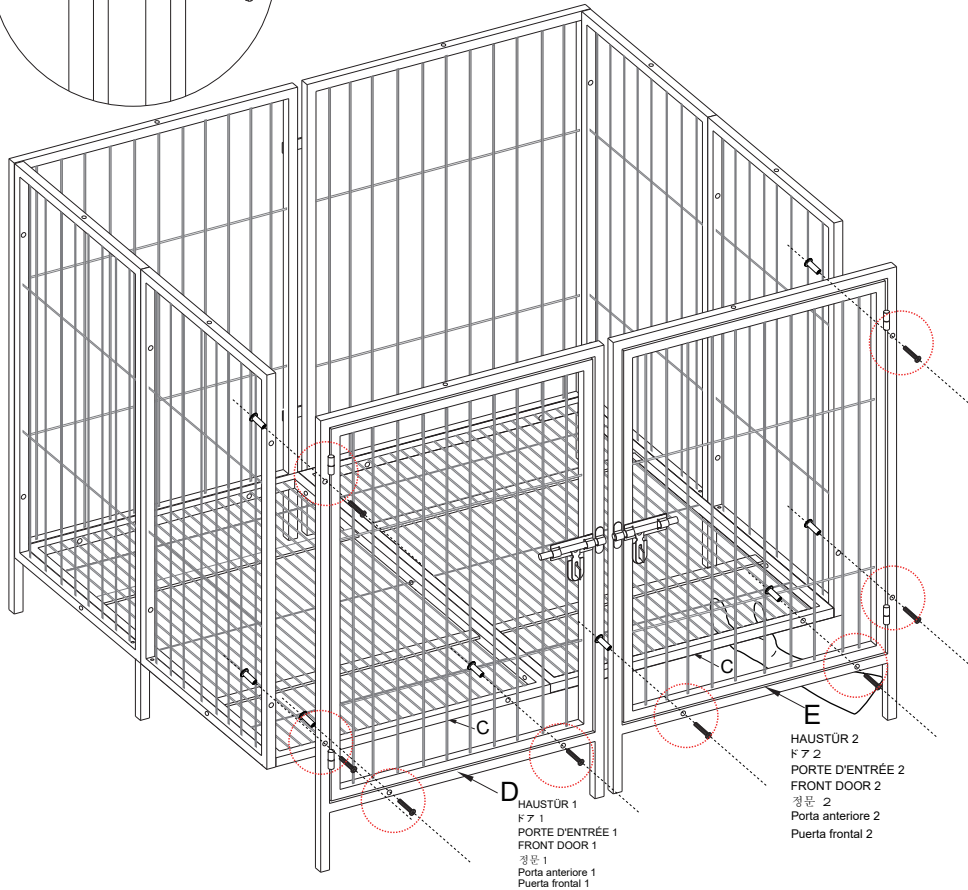
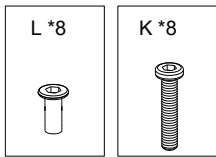
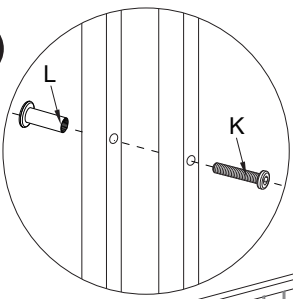

D  
HAUSTÜR 1  
ドア 1  
PORTE D'ENTRÉE 1  
FRONT DOOR 1  
정문 1  
Porta anteriore 1  
Puerta frontal 1

E  
HAUSTÜR 2  
ドア 2  
PORTE D'ENTRÉE 2  
FRONT DOOR 2  
정문 2  
Porta anteriore 2  
Puerta frontal 2

▶Attention: Please holding the C fitting with hands so as to make sure the hole positions are aligned when assembling the D and E fittings.

▶Hinweis: Bei der Montage der Teile D und E bitte Teil C mit den Händen abstützen, um sicherzustellen, dass die Löcher ausgerichtet sind.

▶注意: 部品Dと部品Eを取り付けるとき、ネジ穴を合わせるため、手で部品Cを支えてください。

▶Remarque: Lors de l'installation des pièces D et E, veuillez soutenir la pièce C avec vos mains pour vous assurer que les trous sont alignés.

▶주의하세요: D, E 부품을 설치할 때 C와 구멍을 맞춘 후 진행하십시오.

▶Nota: durante l'assemblaggio dei componenti D ed E, sorreggere il componente C con la mano per allineare i fori.

▶Nota: Durante el ensamblaje de los componentes D y E, sostén el componente C con la mano para alinear los orificios.

6

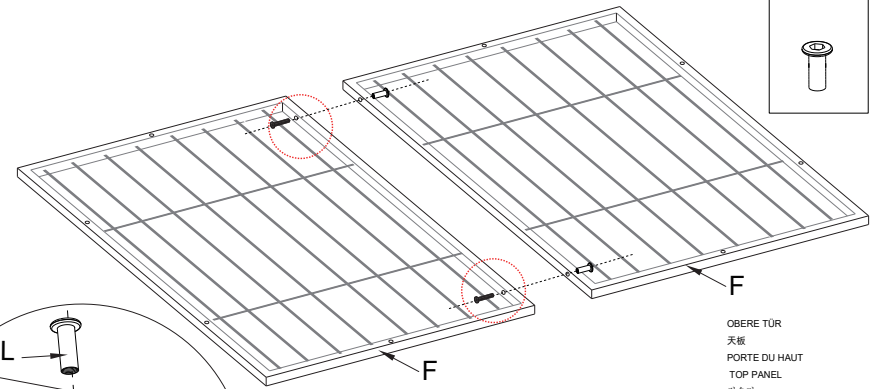
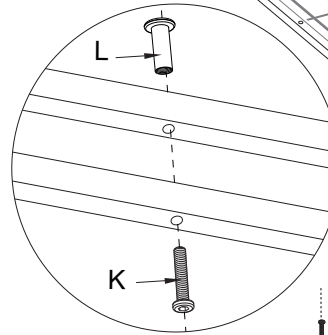
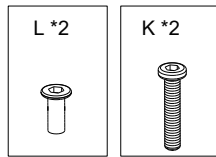

F  
OBERE TÜR  
天板  
PORTE DU HAUT  
TOP PANEL  
정수리  
Pannello superiore  
Panel superior

F  
OBERE TÜR  
天板  
PORTE DU HAUT  
TOP PANEL  
정수리  
Pannello superiore  
Panel superior

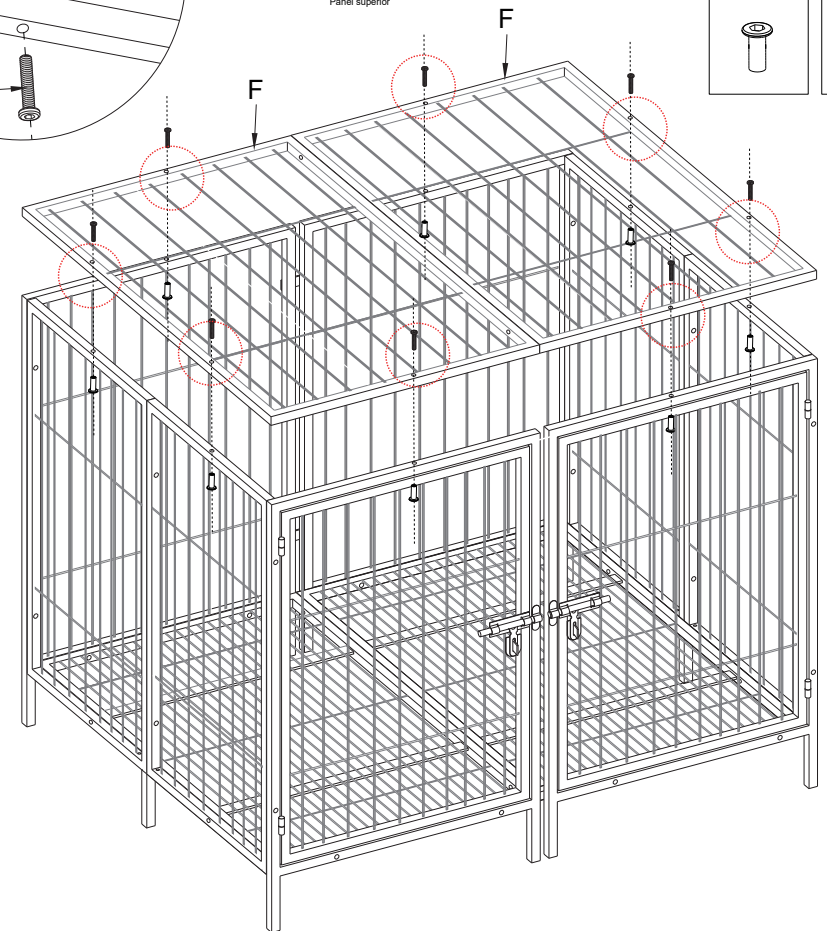
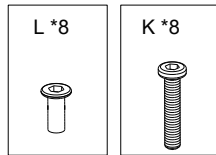

7

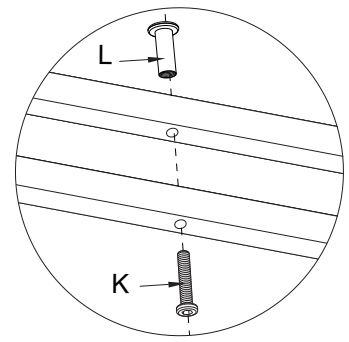
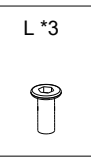

TRENNTÜR  
仕切り  
SÉPARATEUR  
DIVIDER  
개사문  
Pannello divisorio  
Panel divisorio

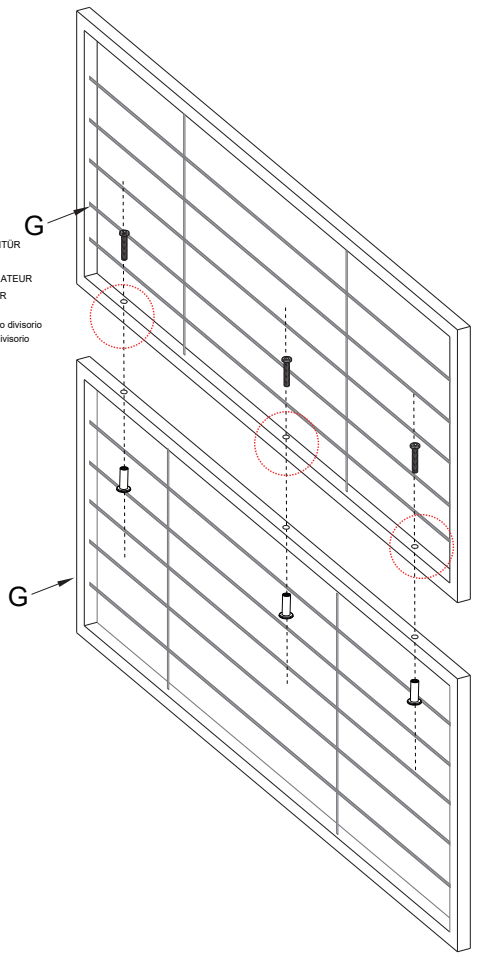

8

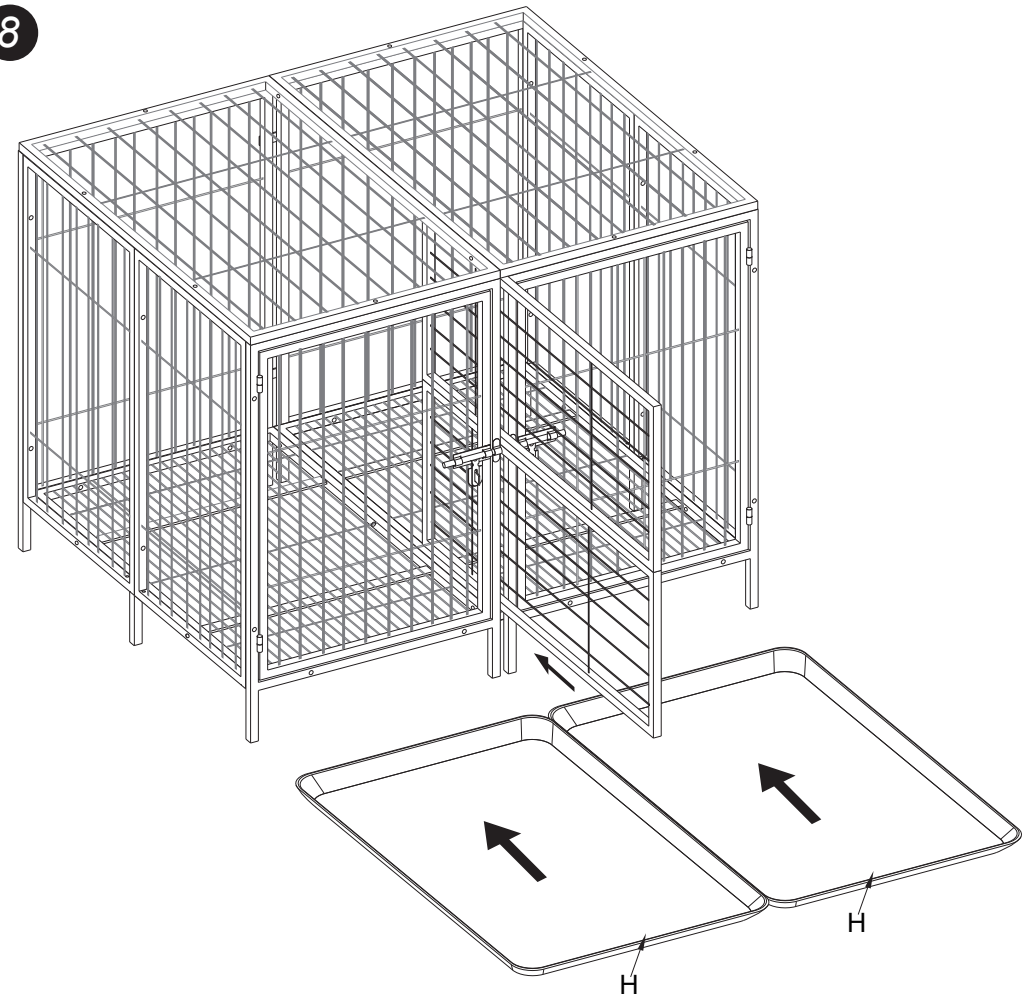

- ▶ Please place some toys to comfort the pets if they can't get used to the cage at first.
- ▶ Haustiere können sich zunächst nicht daran gewöhnen. Bitte bereiten Sie Spielzeug vor, um den Hund zu trösten.
- ▶ 注意：ペットの匂いや飼い主さんの匂いが付いているタオルや玩具などを中に入れておくと、安心して使ってくれるようになるかもしれません。
- ▶ Si les chiens ne peuvent pas s'y habituer dans le cage au début, veuillez préparer des jouets pour les reconforter.
- ▶ 주의：애완동물 냄새나 주인 냄새가 묻어 있는 수건이나 장난감 등을 안에 넣어두면 애완동물에게 안심감을 주고 사용해 줄 수도 있습니다.
- ▶ Se il tuo animale domestico non si adatta immediatamente alla gabbia, prova a mettere alcuni giocattoli per confortarlo.
- ▶ Si tu mascota no se adapta de inmediato a la jaula, intenta poner algunos juguetes para consolarla.