

IMPORTANT, RETAIN FOR FUTURE REFERENCE: READ CAREFULLY.

Check all parts are present prior to assembly.

- Always pre-drill timber to avoid splitting.
- The timber in this product is pressure treated to ensure longevity and protection against rot. This may leave colour variations, but these will even out as the moisture content stabilises.
- Timber is a natural material and will shrink and swell as a result of varying moisture content.
- Keep all plastic bags and parts away from children.

In line with your statutory rights, please check all parts prior to assembly, as assembly of damaged parts may be deemed to be acceptance and this may affect the remedies you are entitled to. If the product is not constructed in accordance with the instructions, or is altered in anyway (e.g. painted), the manufacturer cannot be held liable for any resulting damage.

This article contains biocidal products to give protection against wood destroying insects & wood rotting fungi. Contents may vary.
 May contain : Basic copper carbonate (Copper (II) carbonate – Copper (II) hydroxide (1:1), Cupric oxide, Copper hydroxide carbonate, oxyethyl, ammoniumpropionate, Copper HDO, Propiconazole, Tebuconazole, Boric acid, Benzalkonium chloride.
 Wear gloves when handling freshly treated wood. Avoid breathing dust when cutting treated or untreated wood. Dispose of off-cuts responsibly – do not burn.

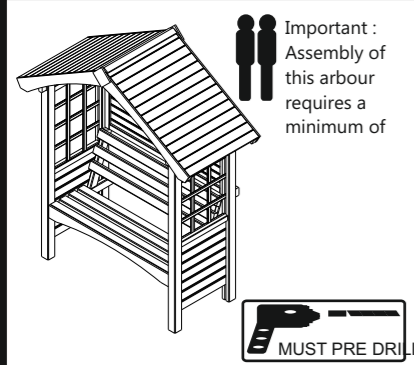

REQUIRED TOOLS : (NOT SUPPLIED)



PARTS:

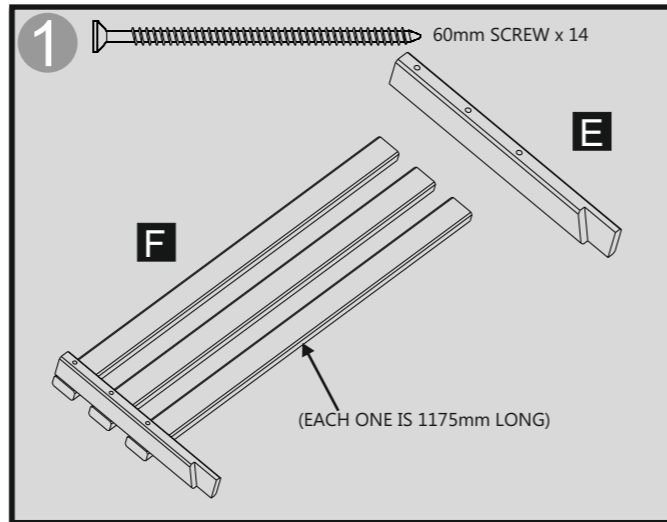
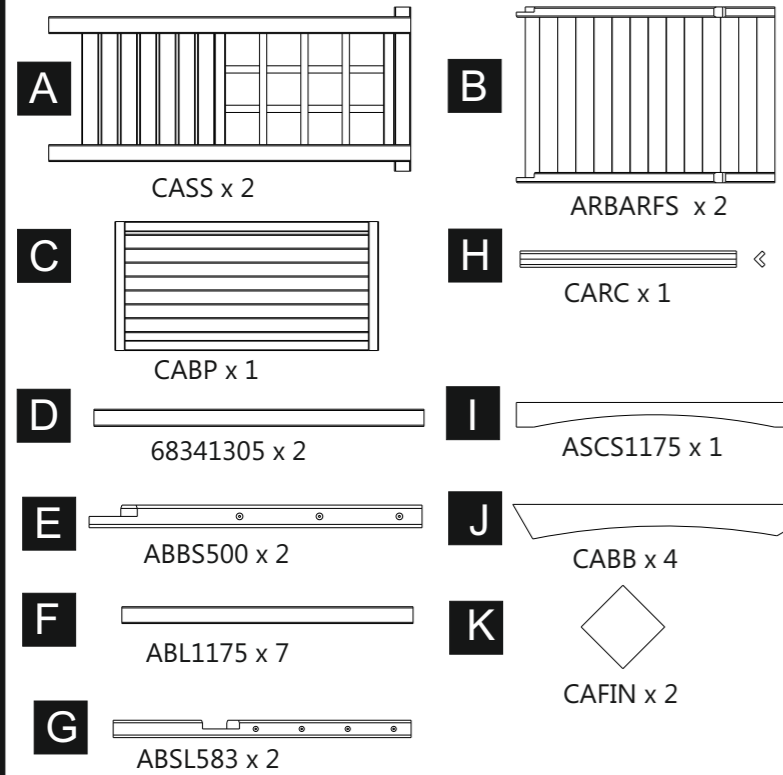

To make up bench back position 3 x part **F** so that they are centred over the pre-drilled holes in 2 x part **E**. Make sure that these are flush on all sides. Secure each part **F** to each part **E** with 60mm screws placed in pre-drilled holes on part **E**. Repeat the step to make up bench bottom using 2 x part **G** and the remaining 4 x part **F**.

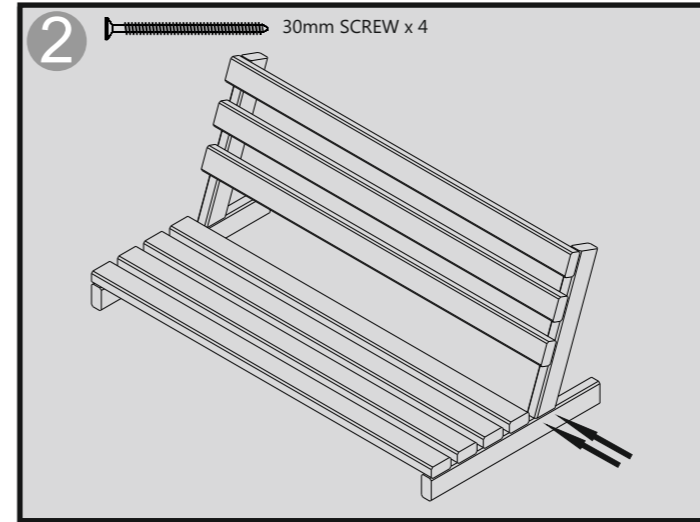

Place bench back into notches on bench base. Secure them together with 2x30mm screws at each end, where the assemblies join, screwing from the outside as shown.

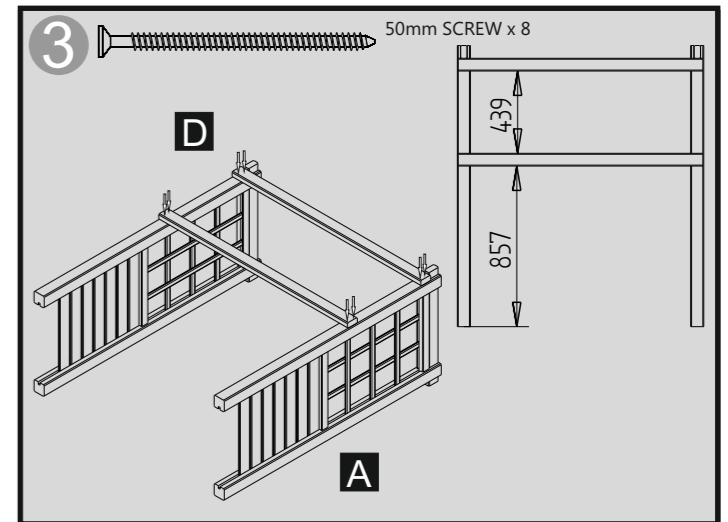

Place 2 x side assemblies **A** on their sides. Place 2 x part **D** (68x34x1305mm battens) on top making sure that they are spaced out as shown and flush at each side. Secure each part **D** in place using 4x50mm screws.

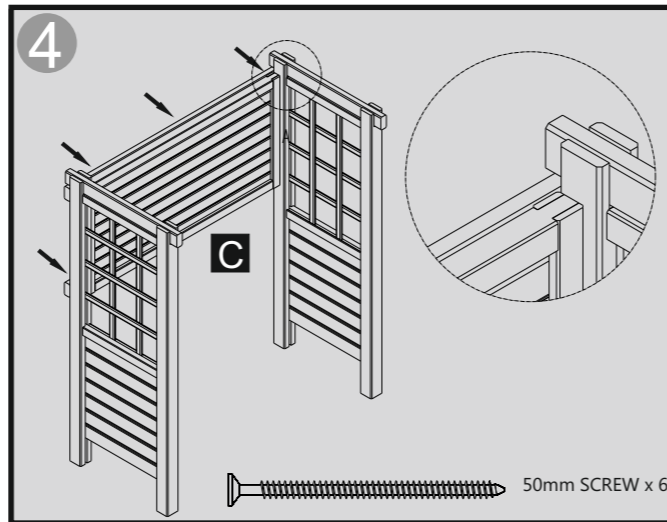

Stand the product up right and place panel **C** so that it fits squarely between the two side sections and is aligned with the two battens you have just secured. Secure into position by screwing from the back through the battens into panel **C** using 6x50mm screws

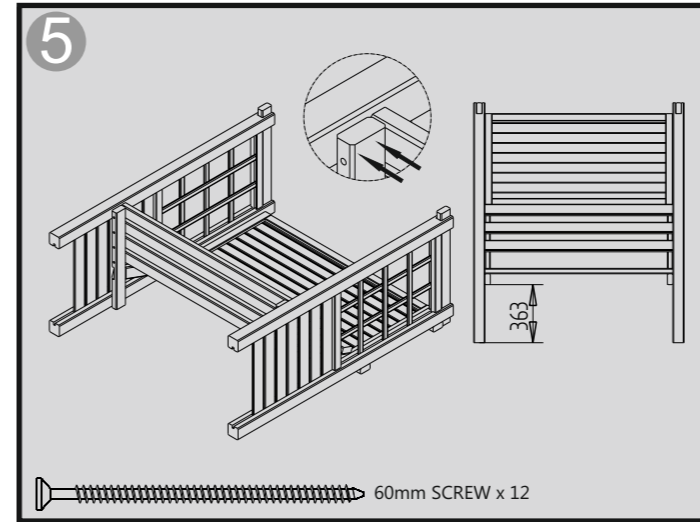

Lie the product down and position the completed seat assembly, that you have previously constructed, 363mm from the post ends. Again, making sure that all sides are flush fix in place by screwing through each end of the seat bottom into each post using 2 x 60mm screws as shown. Secure through bench back into each of the two rear posts with 2 x 60mm screws.

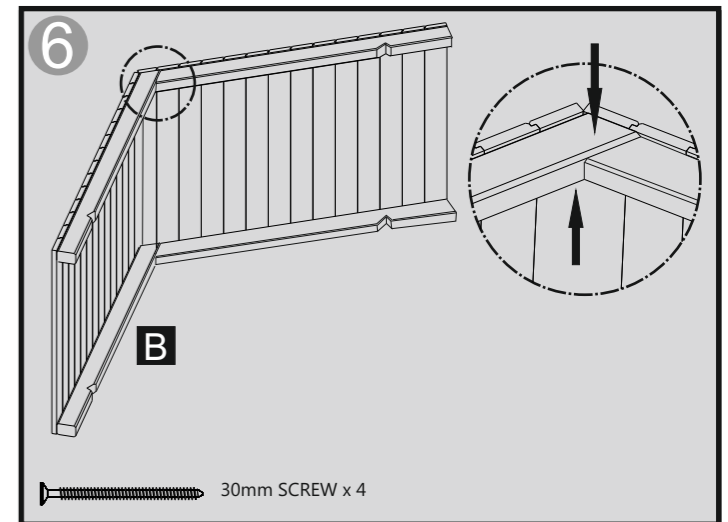

Place the 2 x roof sections **B** together so that they slot together at the apex as shown. Making sure that they are tight and flush, fix them together 1 x 30mm screw placed through each side of each joint.

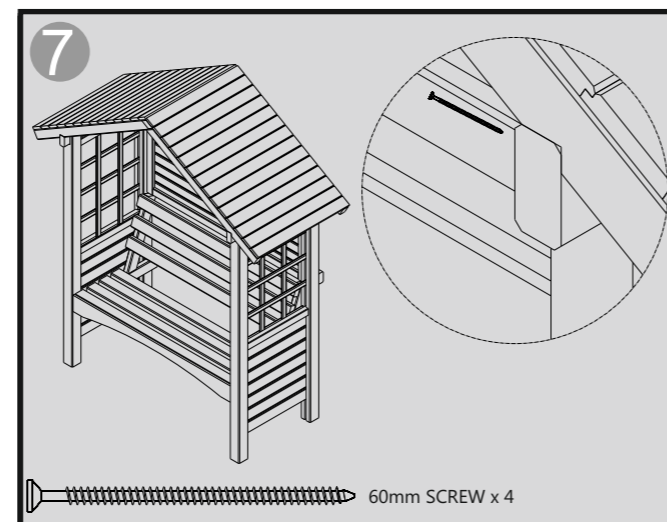

Place the completed roof onto the Arbour so that the notches of the roof sections sit on the side panels as shown. Secure in place with 1 x 60mm screw placed through the top batten of each side section into the notch on each side of each roof section.

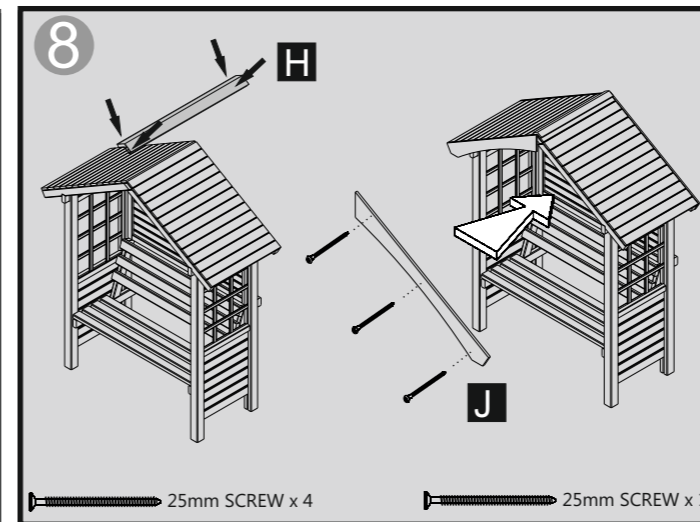

Place roof cap **H** onto the top of the roof and position so that it covers up the joint at the apex. Secure in place using 4x25mm screws. Place barge boards **J** so that they meet at the apex and are flush with the top of the roof sections. Secure each in place using 3x25mm screws

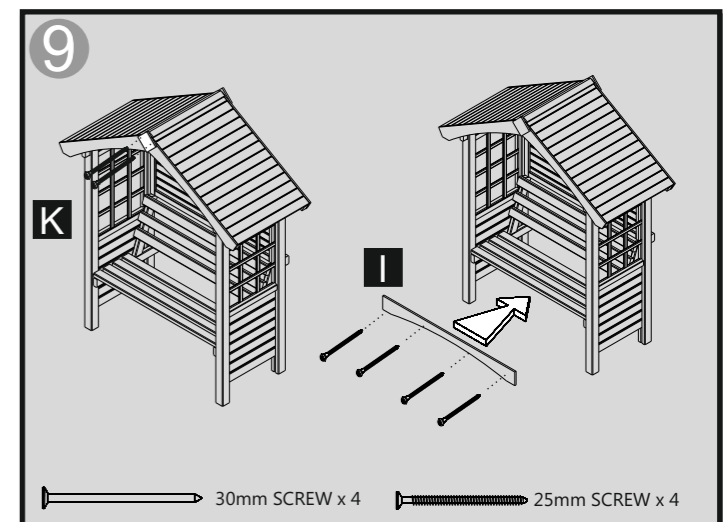

Place finials **K** over the barge boards, where they meet, as shown. Secure each in place using 2x30mm nails. Place the bench fascia **I** against the seat so that it is tight on all sides and flush with the top of the seat. Secure in place with 4x25mm screws.

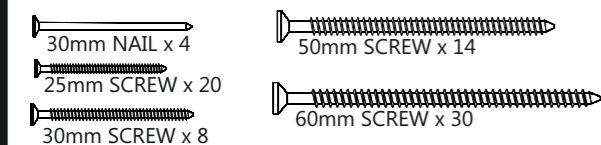

For further information



www.forestgarden.co.uk