

Do montażu
potrzebne są:
Für die Montage
dieser Type
benötigen Sie:
Use the following
for assembly:

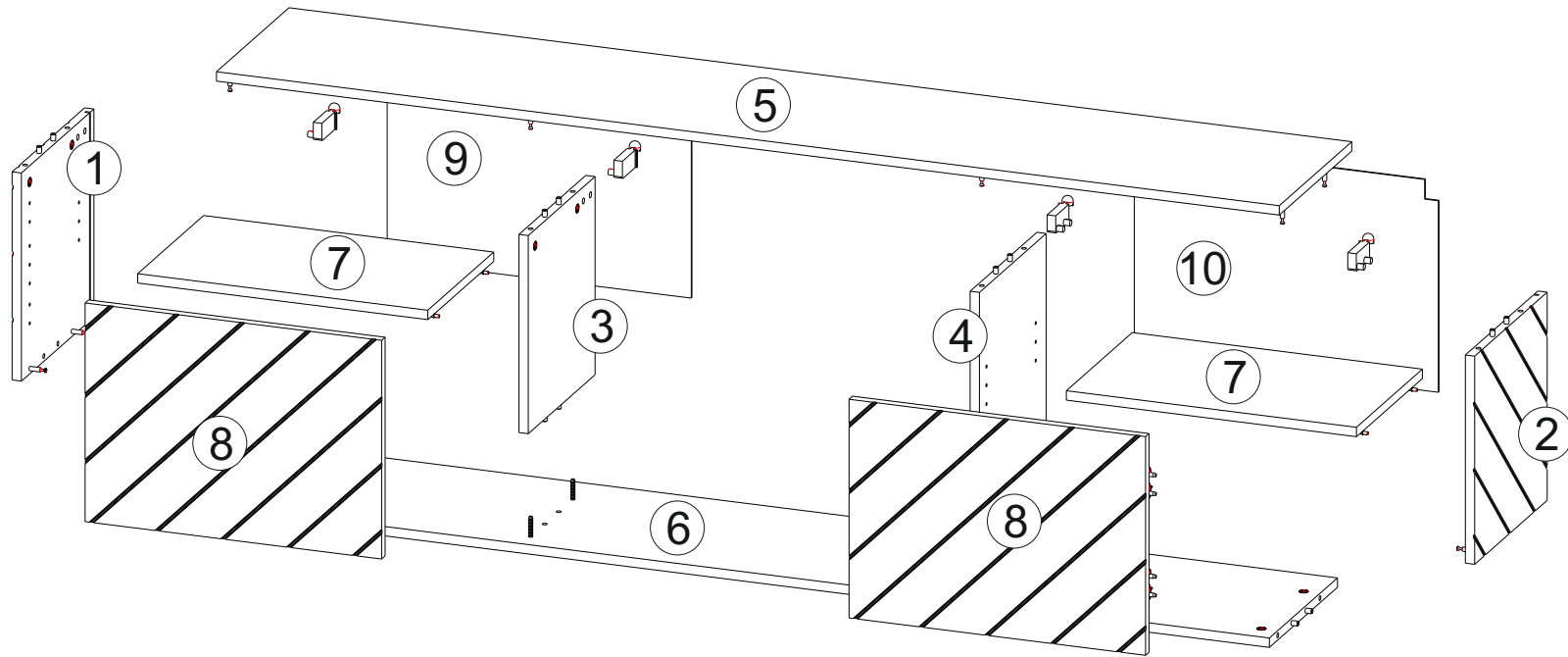

BAG 1

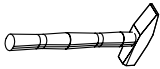
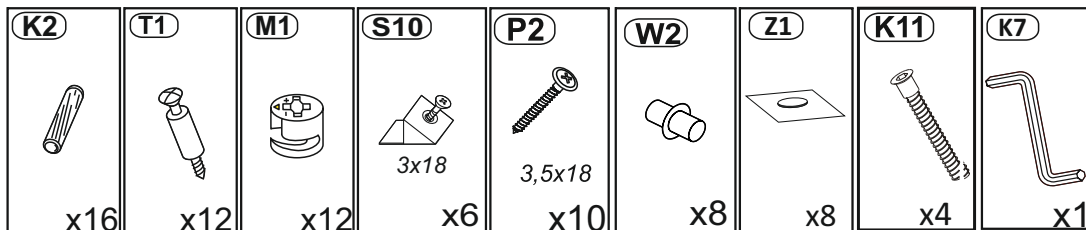

BAG 2

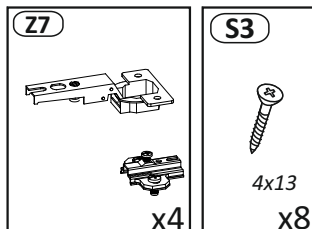

BAG 3

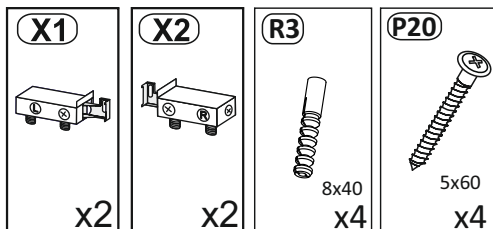

BAG 4

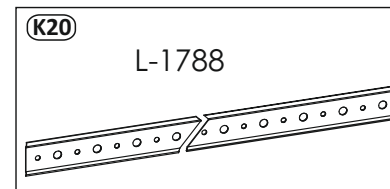
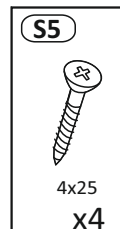

PL

D

GB

INSTRUKCJA MONTAŻOWA MONTAGEANLEITUNG ASSEMBLY INSTRUCTIONS

D Sehr geehrter Kunde, sollte ein Teil fehlen oder beschädigt sein, kreuzen Sie bitte dieses deutlich auf der Montageanleitung an und schicken Sie zu uns ab.

GB Dear customer, Should there be any place missing or damaged, kindly mark this place clearly on the attached assembly instructions and return it to us.

PL Szanowny Kliencie, gdyby brakowało jakiejś części lub byłaby uszkodzona proszę to oznaczyć krzyżykiem na instrukcji montażowej i przesłać instrukcję razem z reklamacją.

1

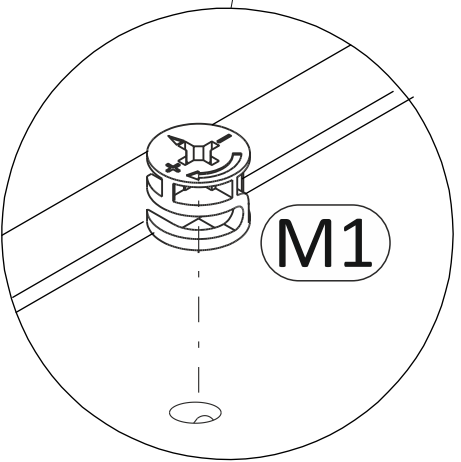
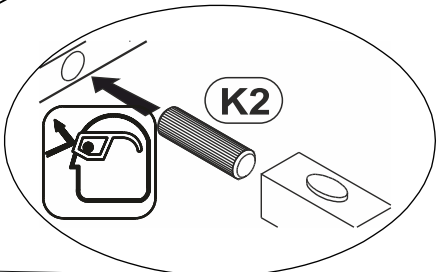
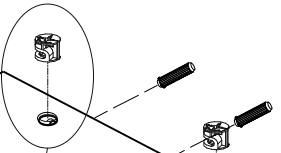
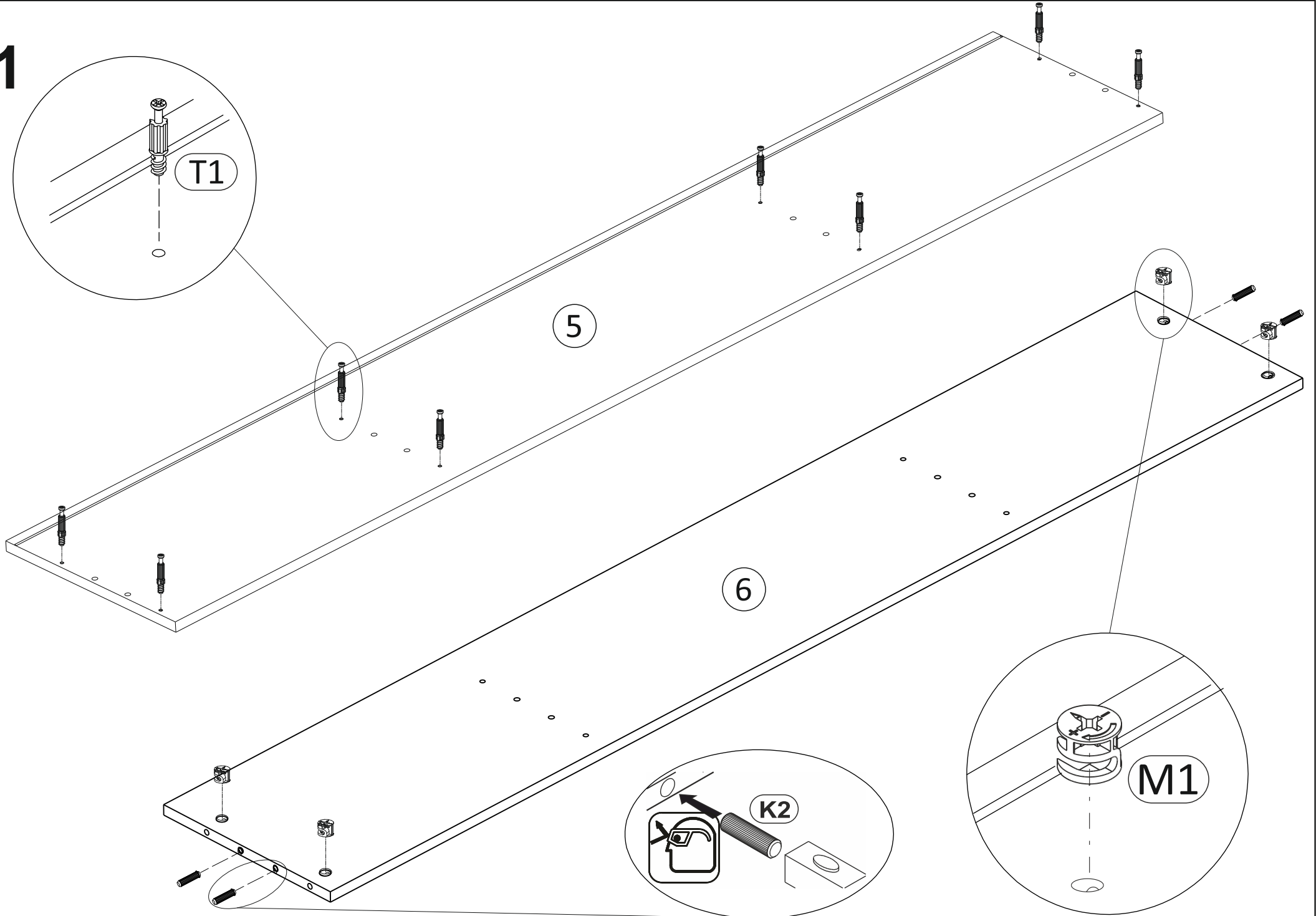
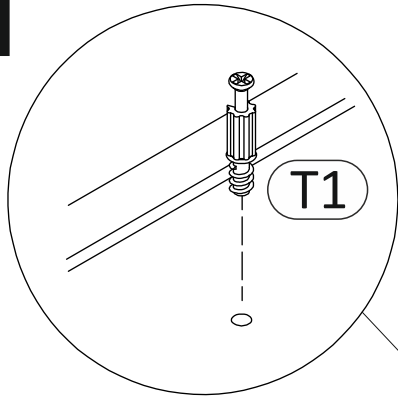

2

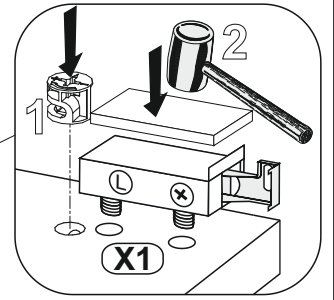
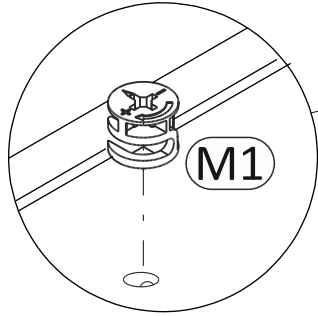
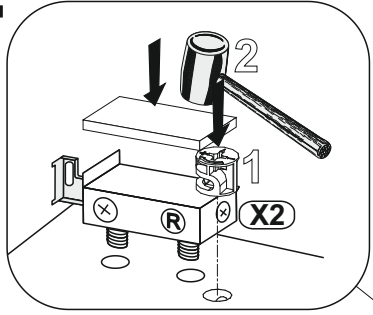

3

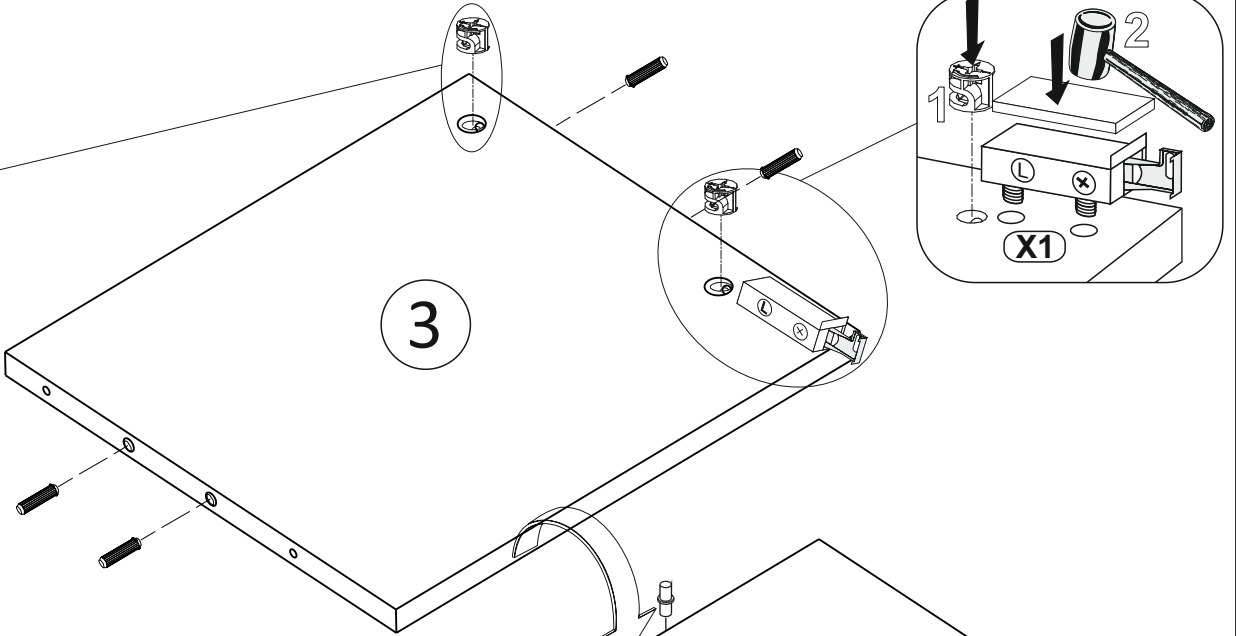

4

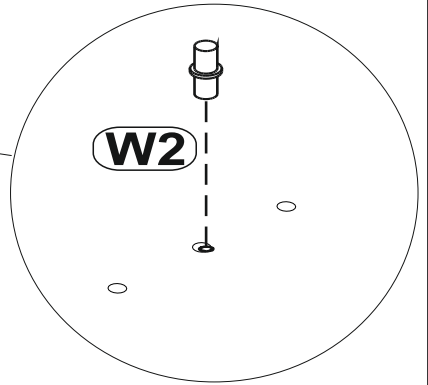
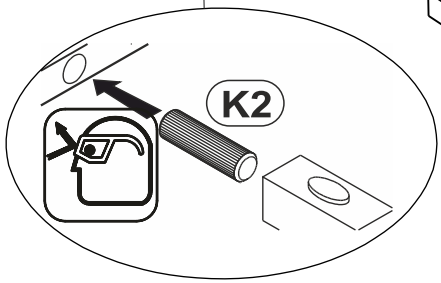
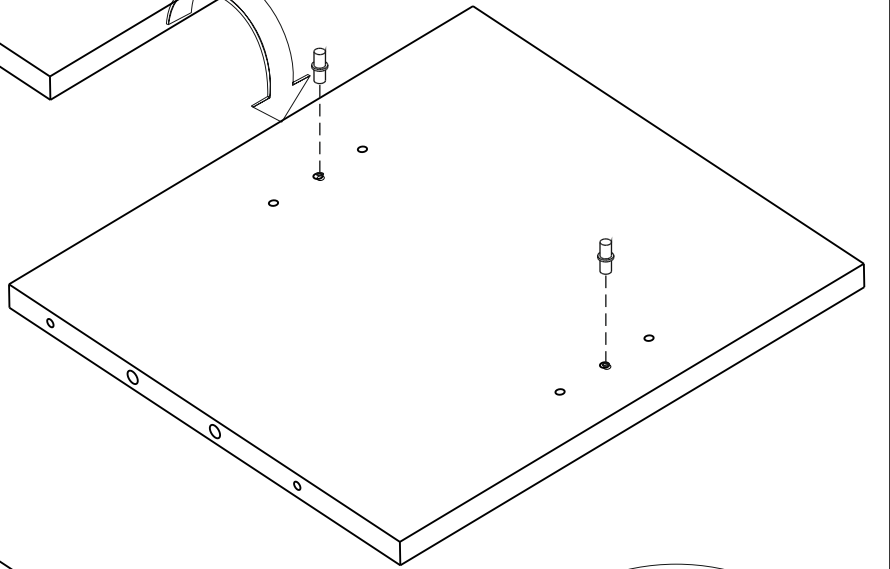
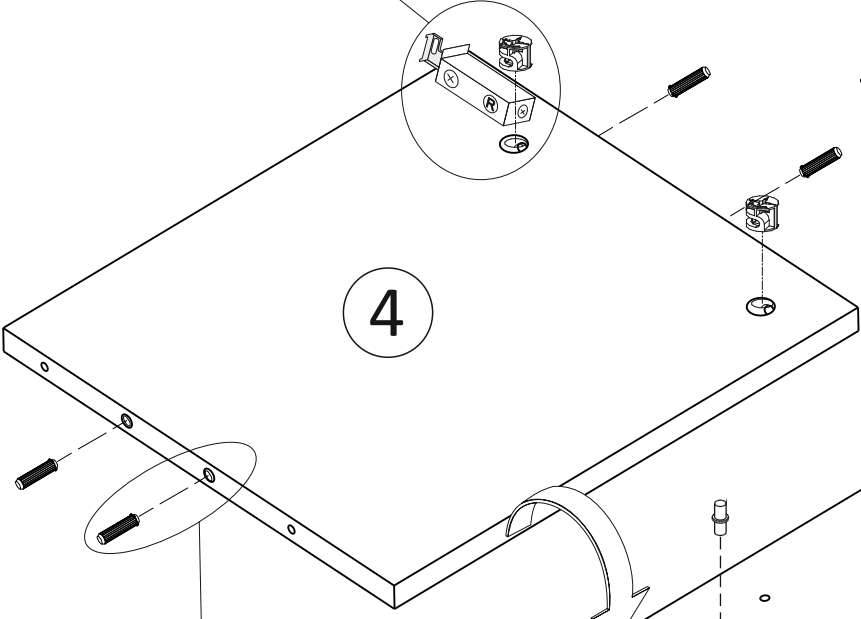

3

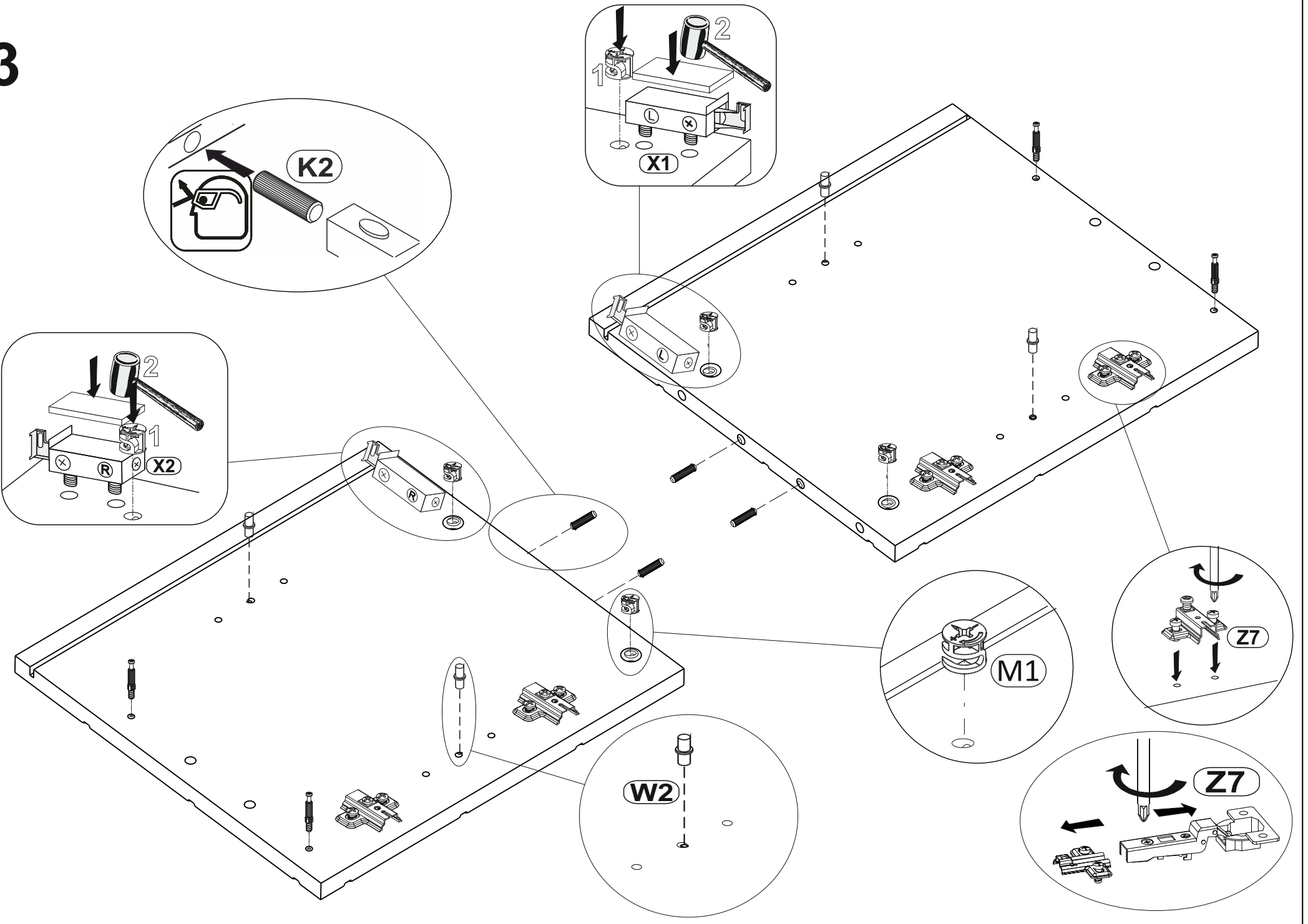

6

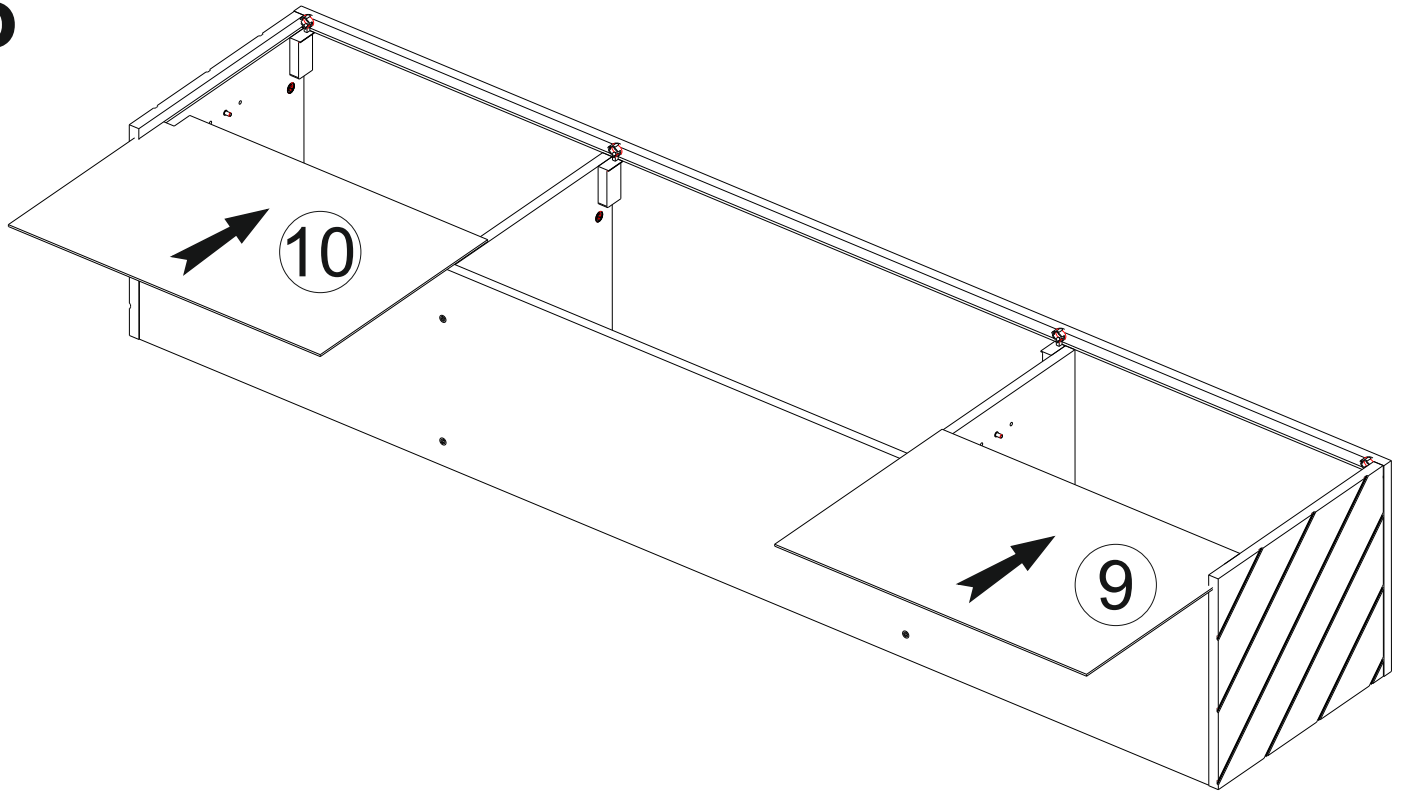

7

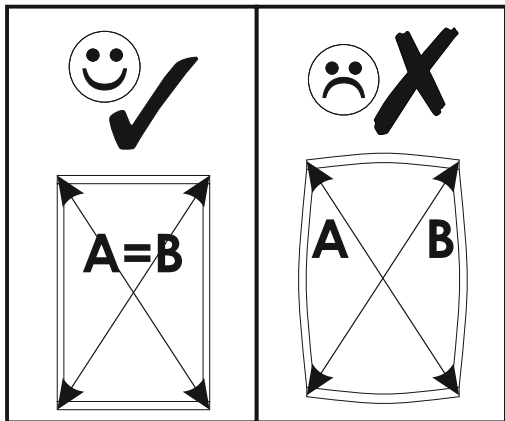
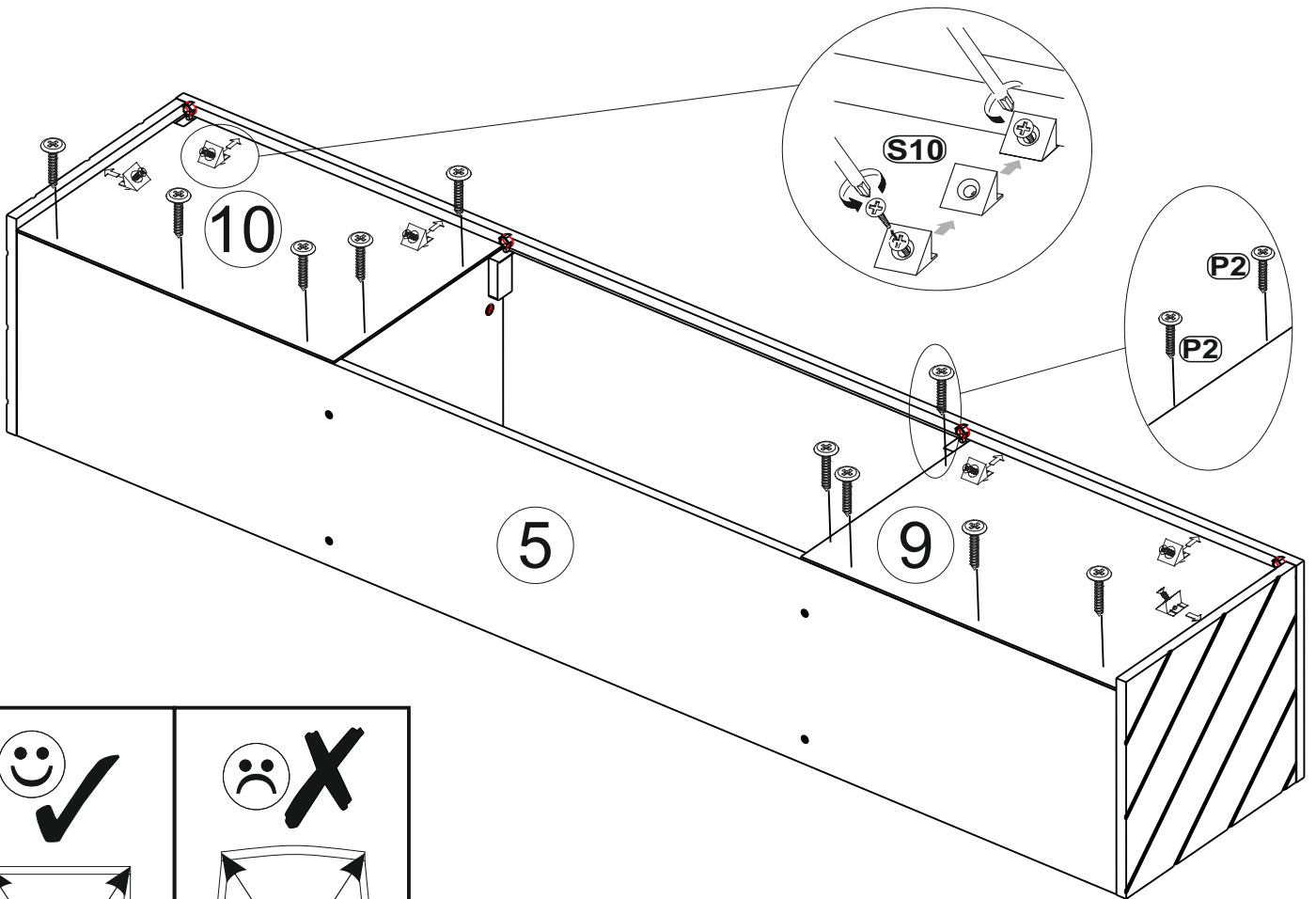

8

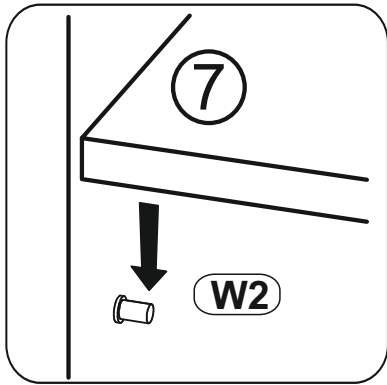
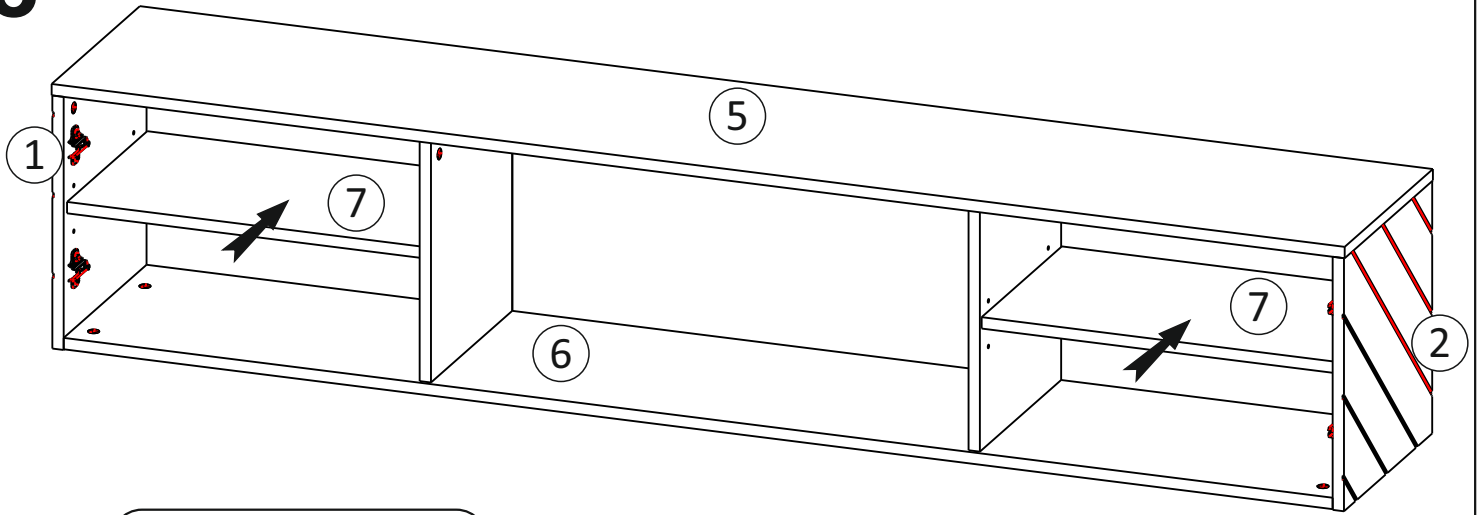

9

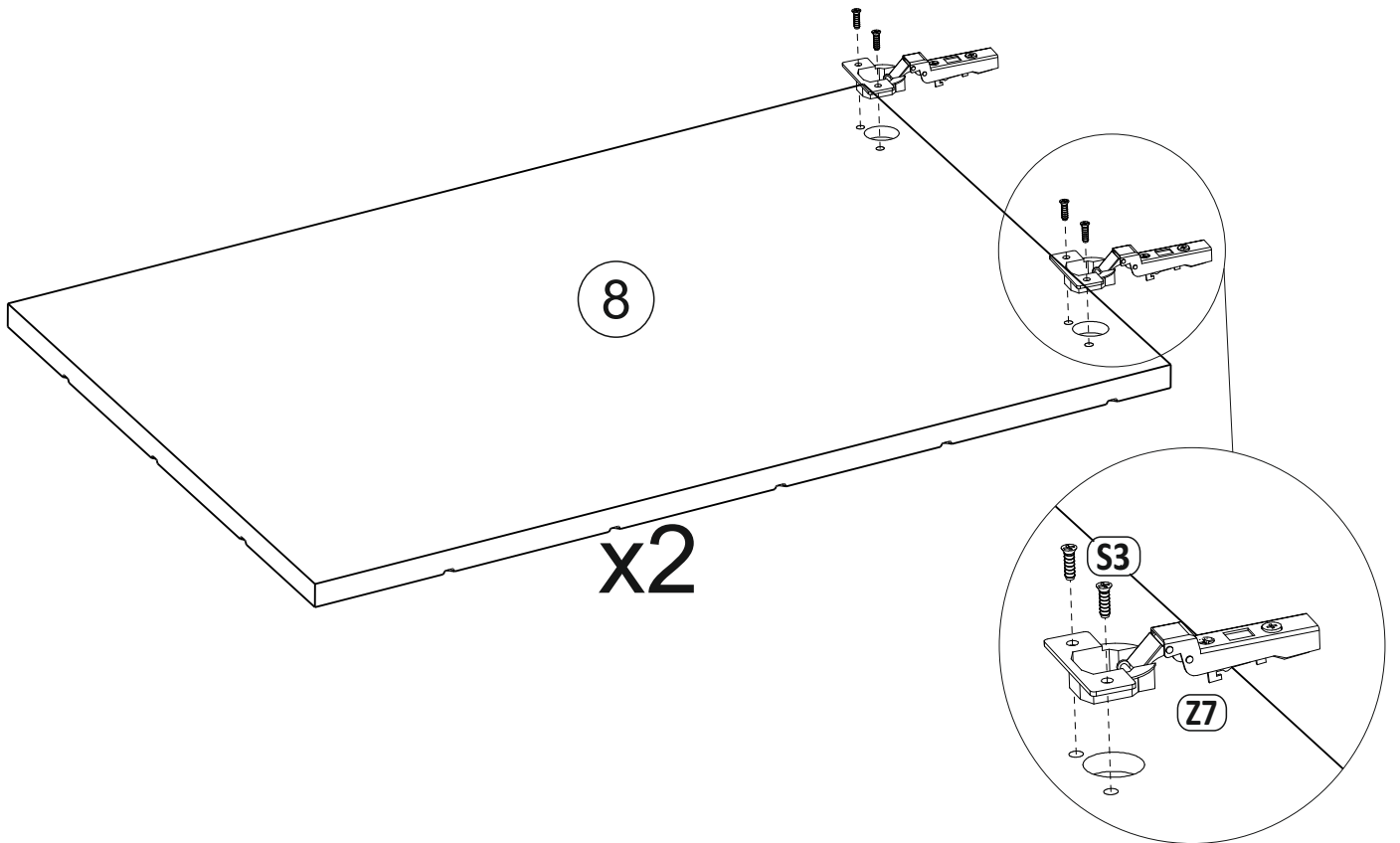

10

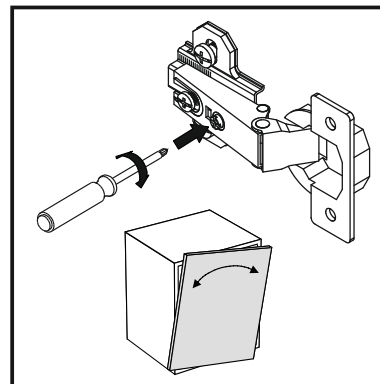
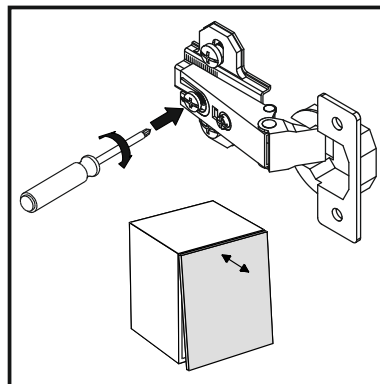
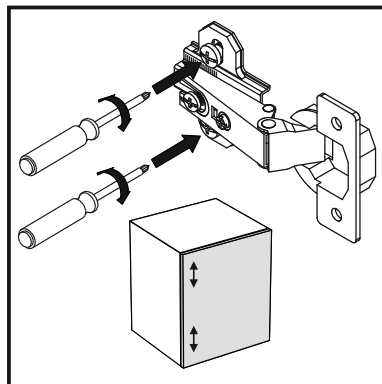
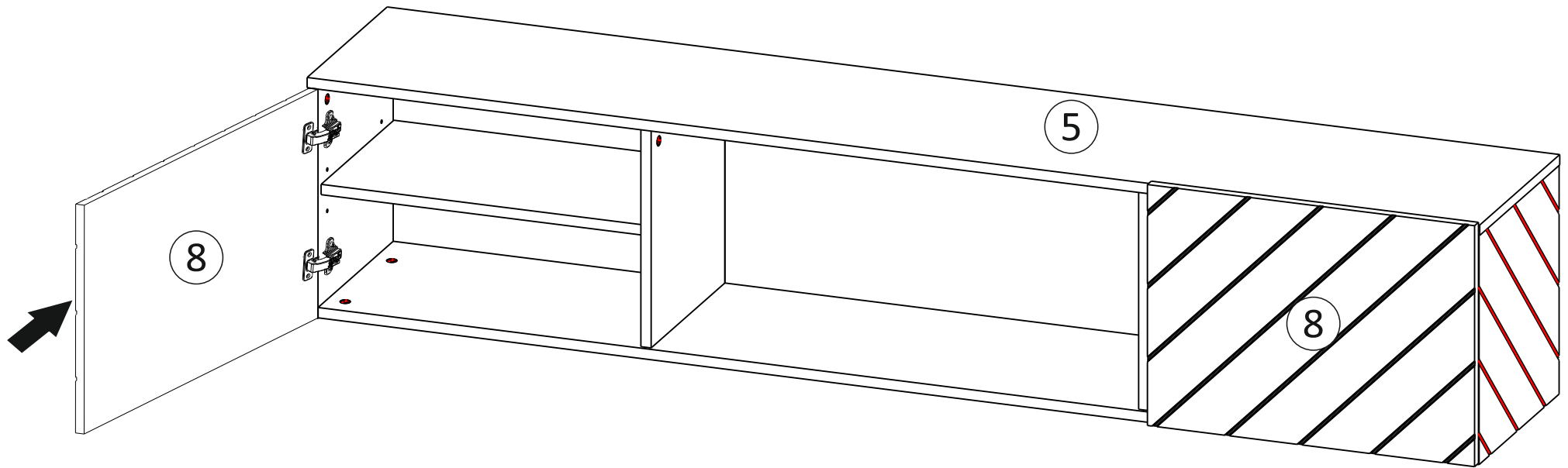
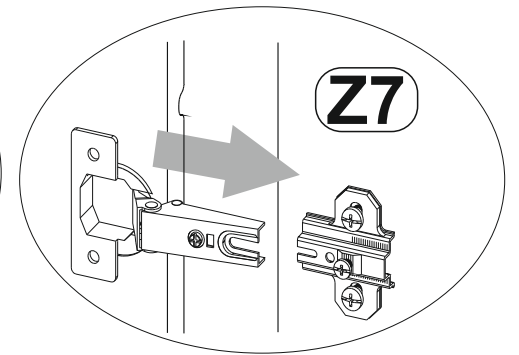
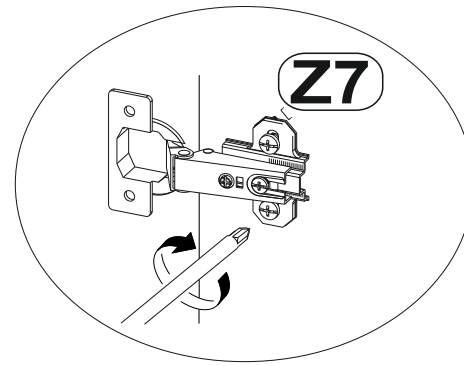

11

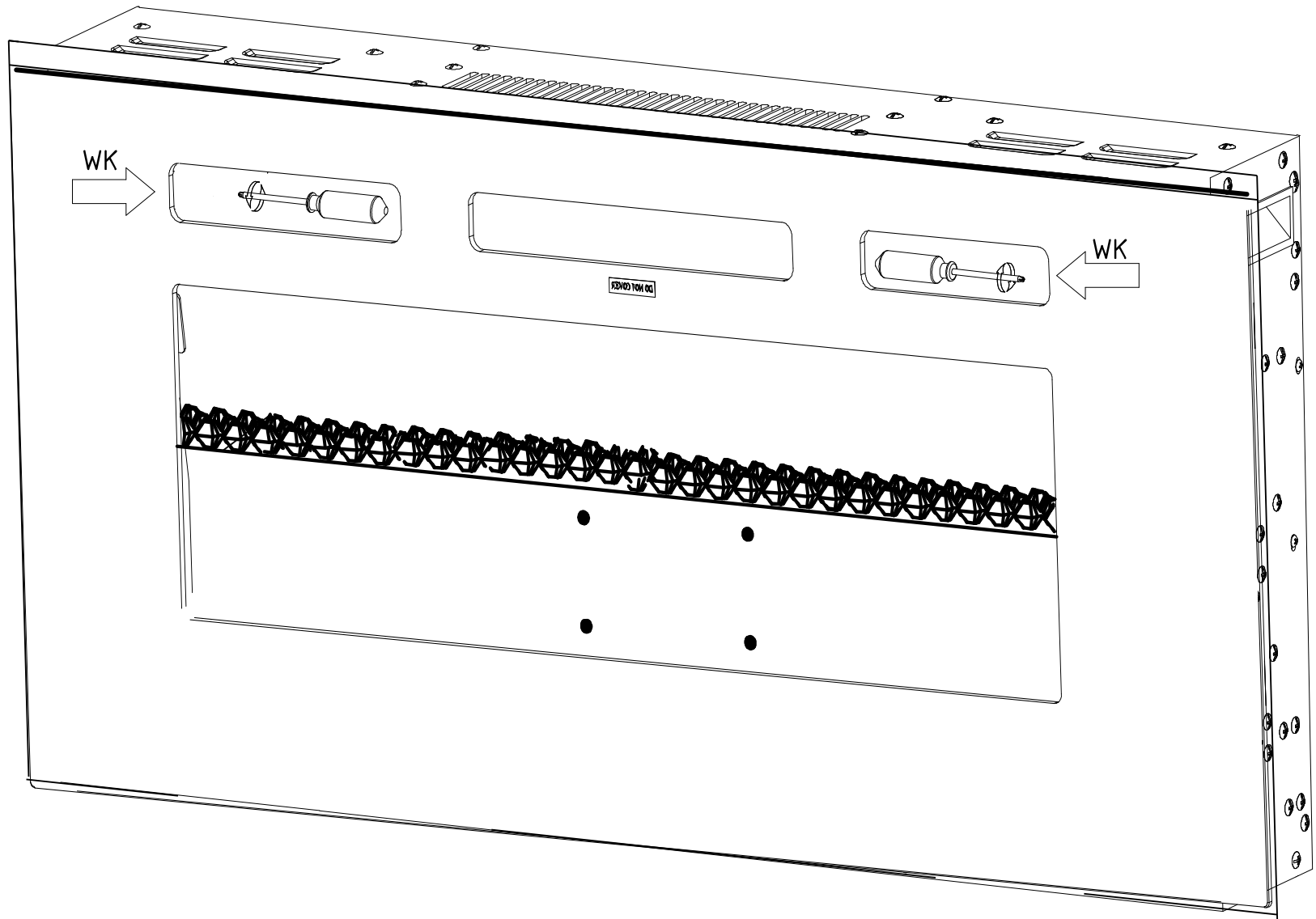

12

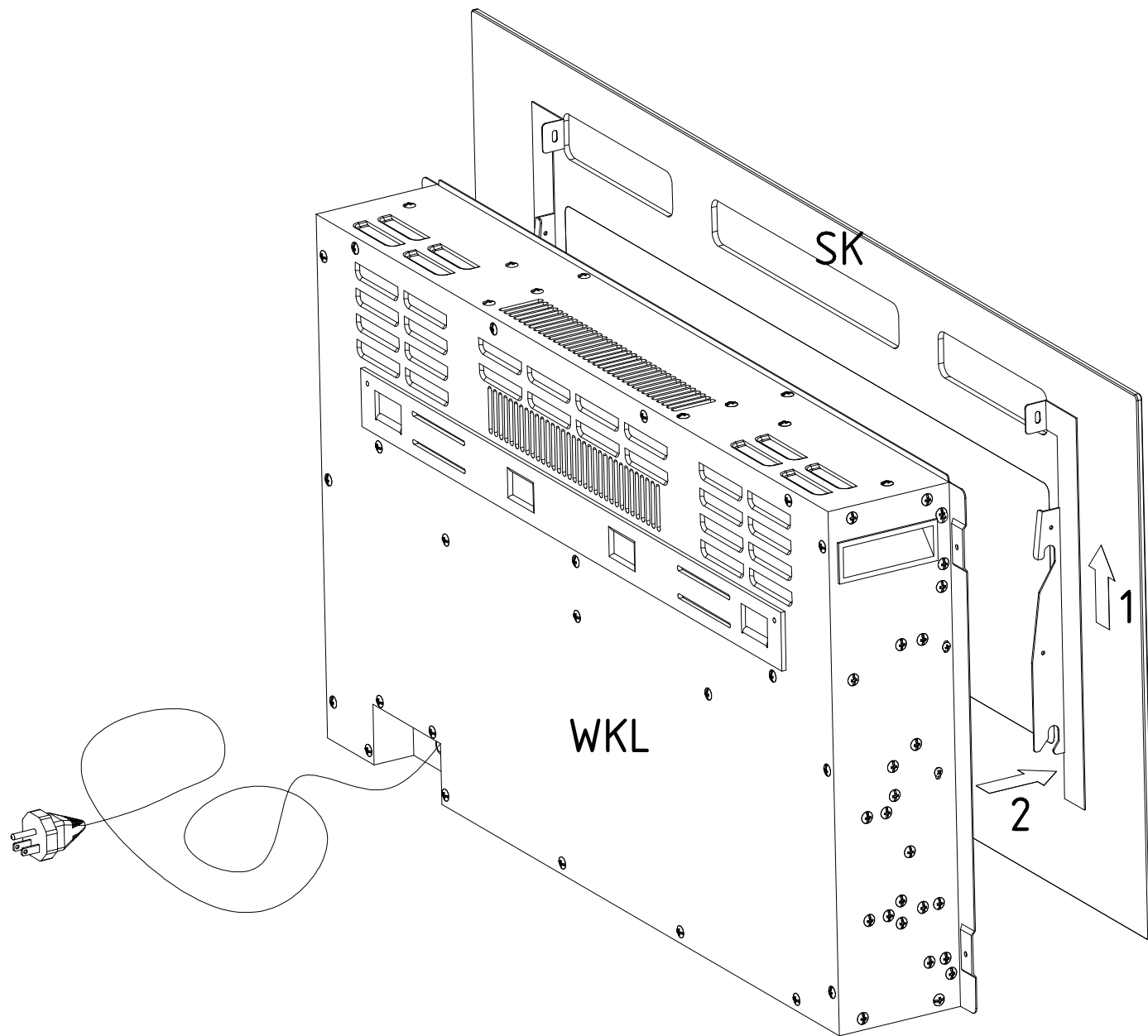

13

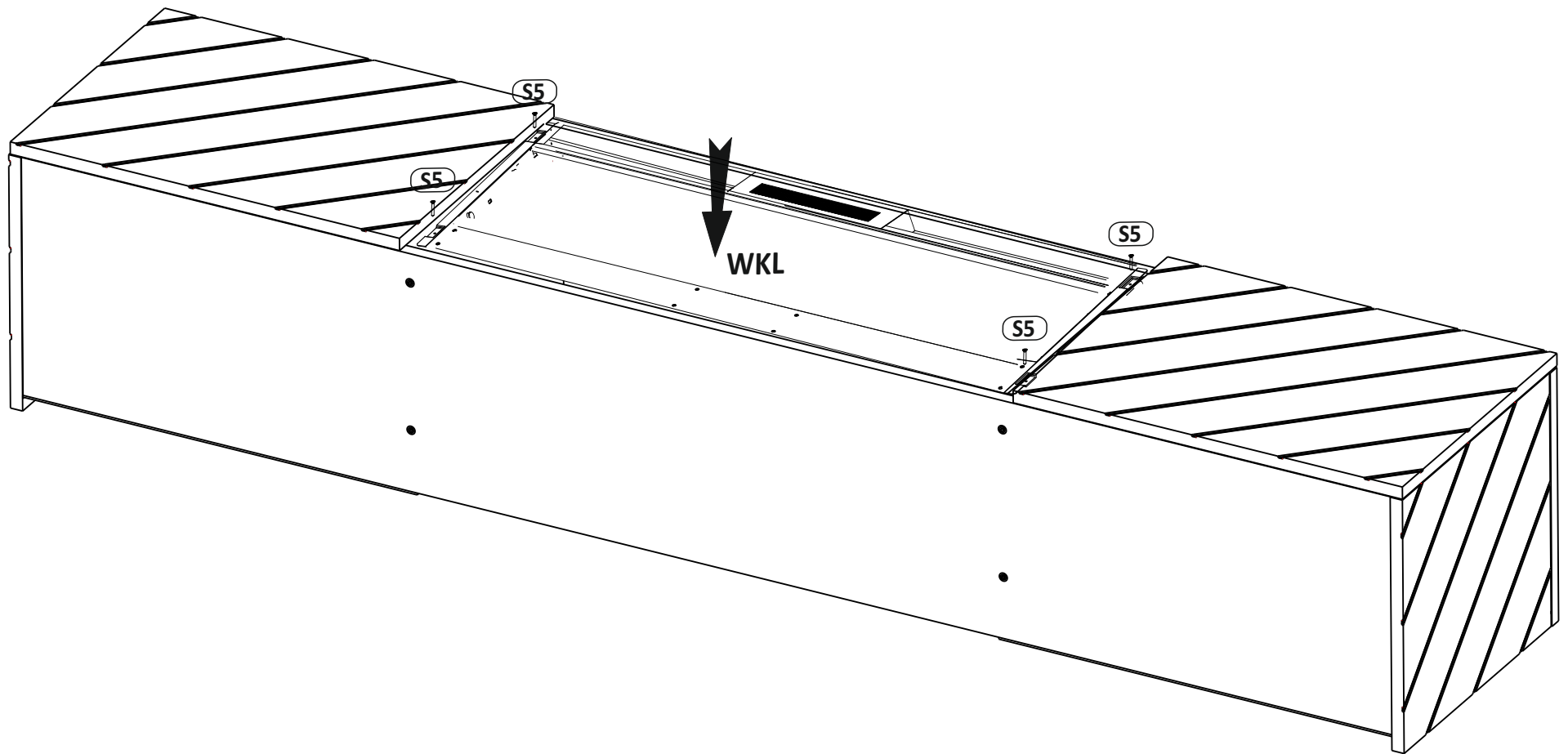

14

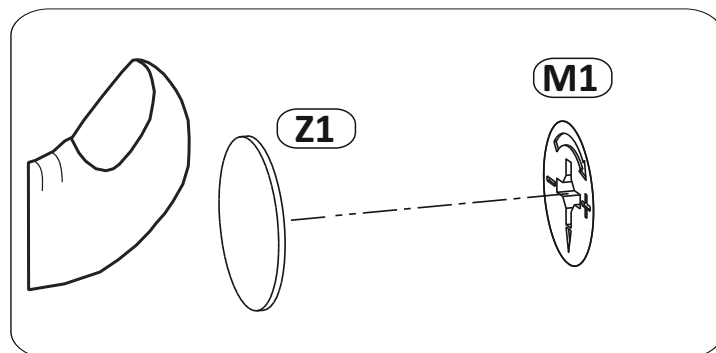
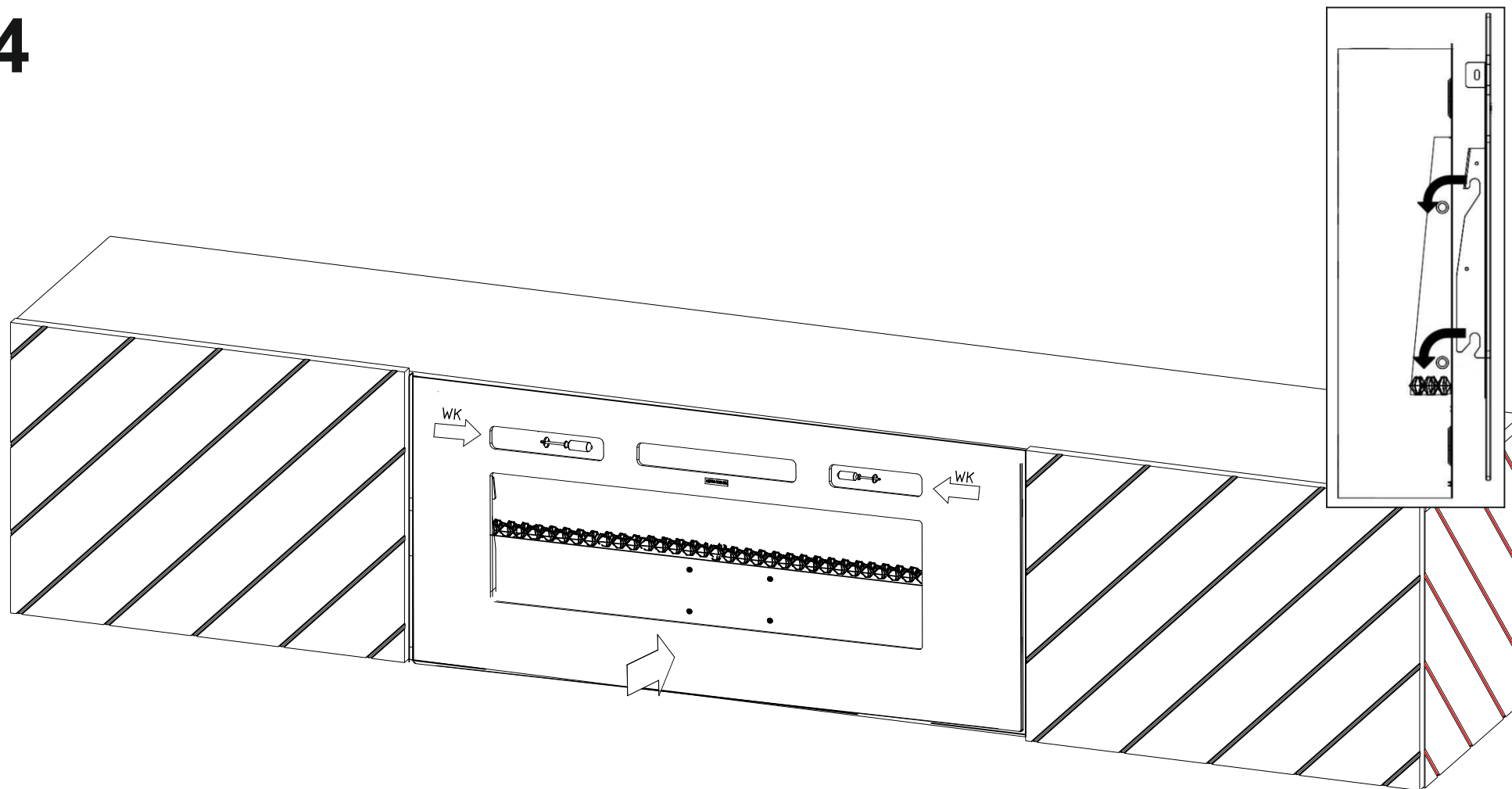

15

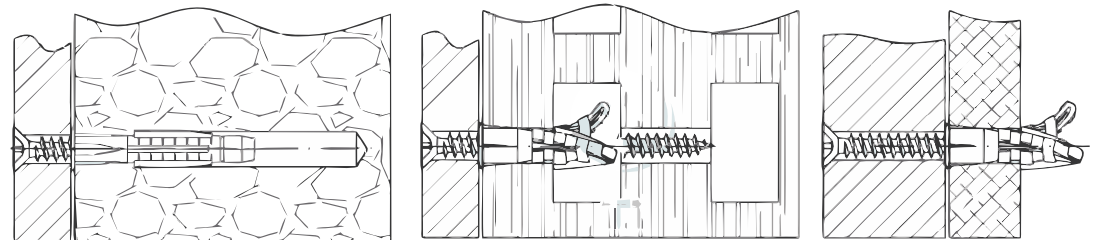
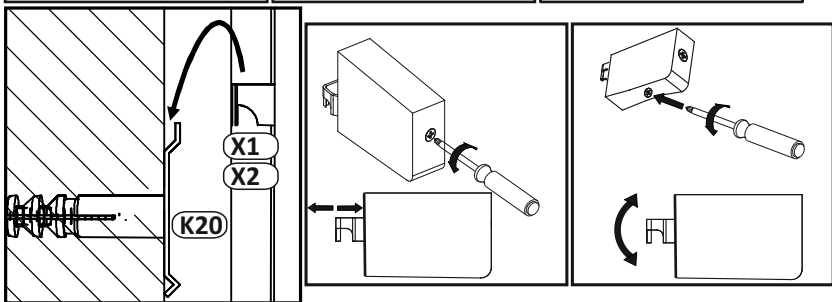
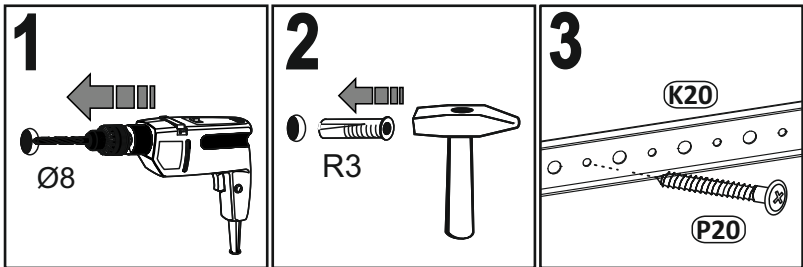
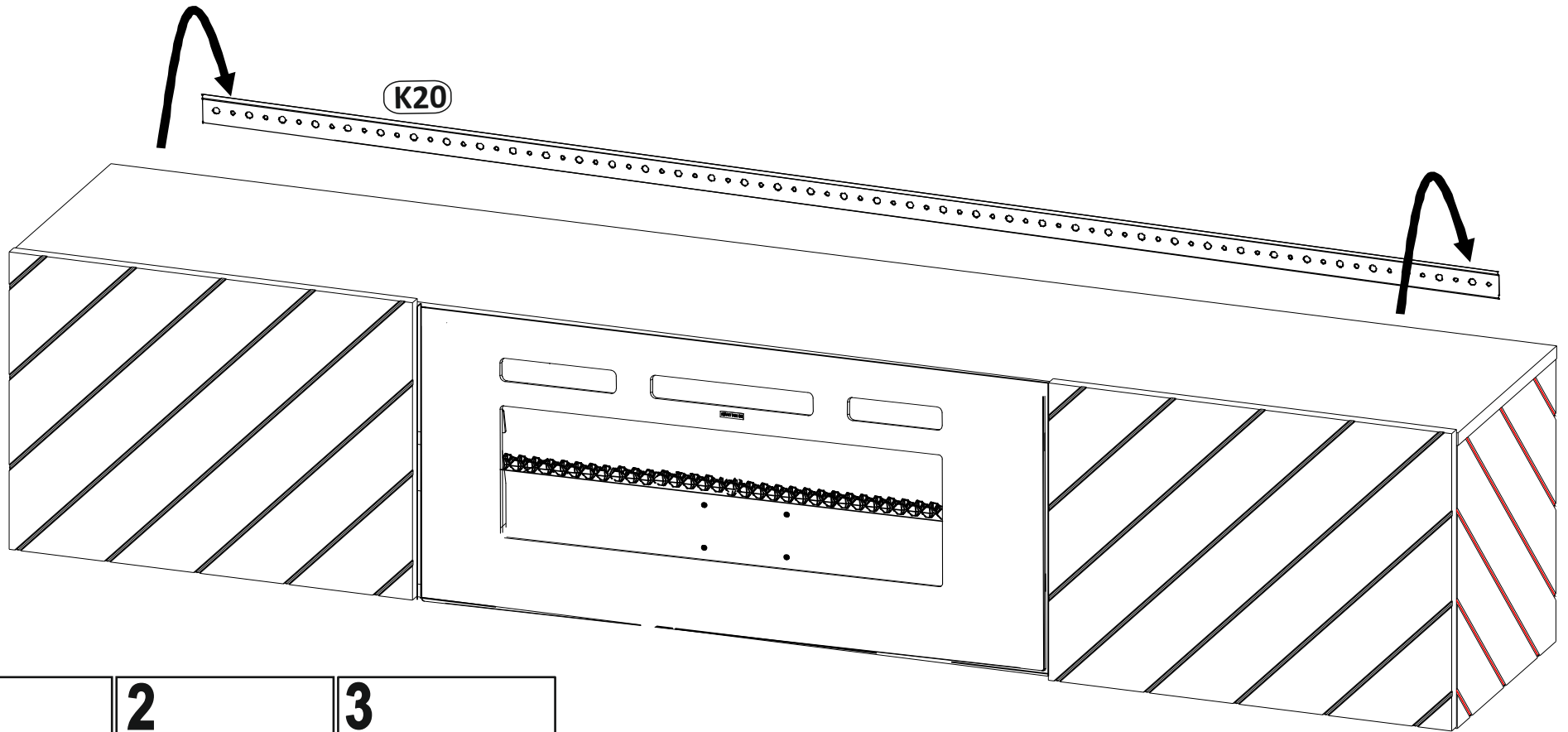

PL - UWAGA!

Nasze powierzchnie o wysokim połysku są fabrycznie ochronione specjalną folią ochronną. Prosimy pozostawić ją na meblach do momentu zmontowania i usunięcia kurzu. Po usunięciu folii ochronnej pozostawić folię połyskową przez 12 godzin w pomieszczeniu do stwardnienia.

EN - ATTENTION!

Our high gloss surfaces have a protective foil when delivered. Please leave this foil on the furniture until it is completely assembled and all dust has been removed. Expose the high gloss foil to the room air for 12 hours to allow it to harden after removing the protective foil.

DE - HINWEIS!

Unsere Hochglanzoberflächen sind bei der Auslieferung durch eine Schutzfolie geschützt. Belassen Sie diese auf dem Möbel, bis es vollständig montiert und von Staub befreit ist. Der Hochglanzfolie nach der Entfernung der Schutzfolie 12 Stunden Zeit zum Nachhärten an der Raum-Luft geben.

CZ - POZOR!

Naše povrchy s vysokým leskem jsou při dodání chráněny ochrannou fólií. Ponechejte ji na nábytku, dokud nebude kompletně smontovaný a nebude z něho odstraněný prach. Po odstranění folie dejte nábytku 12 hodin čas na vytvrzení v pokojové teplotě.

SK - POZOR!

Naše vysoko lesklé povrchy sú chránené špeciálnou ochrannou fóliou. Prosím, nechajte ju na nábytku, kým nábytok nezmontujete a neodstránite prach. Po odstránení ochrannej fólie nechajte lesklý film 12 hodín v miestnosti vytvrdnúť.

HU - FIGYELEM!

Az általunk gyártott bútorok magas fényű felületei speciális védőfóliával gyárilag védettek. Kérjük a védőfóliát ne távolítsák el a bútor összeszereléséig, és a por szerelést követő eltávolításáig. A védőfólia eltávolítását követően tartsuk a bútort 12 órán át a fóliázott felületek megkeményedésére alkalmas környezetben.

HR - PAŽNJA!

Dijelovi namještaja u visokom sjaju imaju na sebi zaštitnu foliju prilikom isporuke. Molimo vas da tu foliju ostavite na namještaju dok nije u potpunosti montiran i dok nije odstranjena sva prašina u prostoru. Nakon uklanjanja zaštitne folije dijelove namještaja u visokom sjaju izložiti sobnom zraku 12 sati.

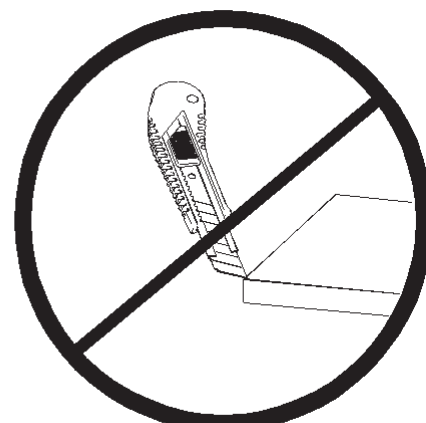
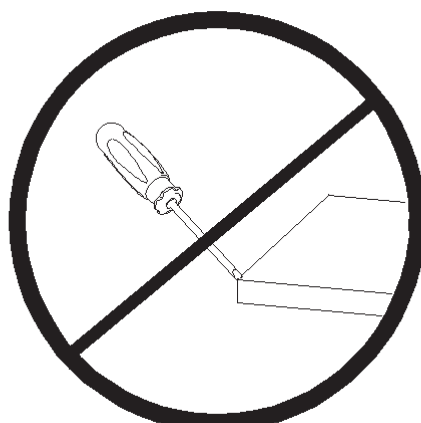
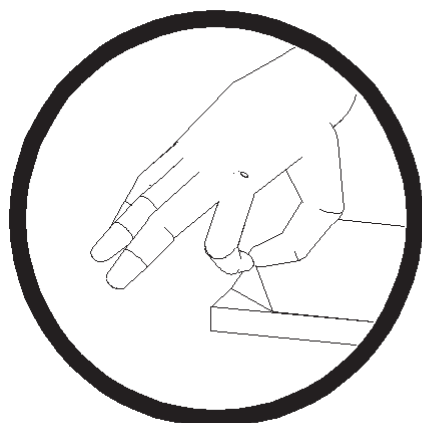

IMPORTANT SAFETY INFORMATION

ELECTRIC FIREPLACE SAFETY INFORMATION AND WARNING

ATTENTION: This Safety Information and Warning provides basic information for using an electric fireplace insert safely. Failure to follow the recommendations and warnings below may result in risk of fire, electric shock, and injury to person and property.

- **WARNING!** There's a risk of fire, electric shock, and injury to person if you don't follow the included instruction and safety information. We are not liable for any damages or injury caused by mishandling, improper installation, or improper use of the electric fireplace insert.
- **WARNING!** Prior to using your electric fireplace insert, compare the rated power of the electric fireplace insert to the capacity of the electrical circuit you plan to use it within. In order for the electric fireplace insert to be safely used, the electric fireplace insert's electrical demand, in addition to the electrical demand of any other electric devices using the circuit, should be well within the electrical capacity of the circuit. If you are unsure of the electrical capacity of the circuit, or the electrical demand of devices using the circuit, contact a licensed electrician for assistance.
- **WARNING!** Your electric fireplace insert may require a dedicated electrical circuit. Check with your local building codes.
- **WARNING!** To avoid electrical shock, do not open the back panel of the insert unless the power has been turned off and the insert has been unplugged.
- **WARNING!** The electric fireplace insert must be used on an AC supply only, and the voltage marked on the heater must correspond to the supply voltage.
- **WARNING!** Any repairs or modifications done to this electric fireplace insert are not recommended, and may cause an increased risk of fire, electric shock, and injury to person. Any repairs or modifications will void all warranty and technical support for this unit. If the decision of the user of the electric fireplace insert is to repair or modify the insert or any electrical wiring, such repairs or modifications should be done only by a licensed electrician, and must comply with local building codes.

- **WARNING!** Discontinue the use of this electric fireplace if any of the following has occurred:
 - Water damage
 - Insert has been damaged or dented
 - Power cord has become broken
 - Power cord has become too hot to touch
 - Insert smokes or smells like smoke (Note: When the heater function is used for the first time, a slight odor may be present. This is normal and should not occur again unless the heater is not used for an extended period of time.)
- **WARNING!** Do not cover or obstruct the insert in any way. The insert will overheat if covered.
- **WARNING!** Never immerse the product in water or any other liquids.
- **WARNING!** Do not run cables under carpets or rugs. Do not allow the main cables to hang over the sharp edges of the electric fireplace insert. Do not allow the main cables to come into contact with hot surfaces. From time to time, check the cable for damage. Never use the electric fireplace insert if the cable or any part of the insert shows signs of damage.
- **WARNING!** Do not switch the electric fireplace insert on until it has been properly installed as described in the instruction manual. Do not leave the electric fireplace insert unattended during use.
- **WARNING!** Keep the electric fireplace insert out of the reach of children. Do not let children operate the electric fireplace insert.
- The electric fireplace insert is fitted with a safety cut-off which will trigger if the insert overheats (e.g. due to blocked air vents). For safety reasons, the insert will NOT automatically reset. To reset the electric fireplace insert, disconnect the insert from the power supply for at least 15 minutes. After 15 minutes, reconnect the insert to the power supply and switch the insert on.

SAVE THIS SAFETY INFORMATION AND WARNING FOR FUTURE REFERENCE