

Installation Manual of Bed

Dear Valued Customer:

Thank you for choosing our brand and purchasing our bed frame!

We are thrilled to have earned your trust and we want to ensure that you are completely satisfied with your purchase. To help you get the most out of your new bed frame, we would like to share some useful tips on cleaning and maintenance.

When cleaning your bed frame, we recommend using a soft, slightly moist cloth. Avoid using corrosive detergents, wire brushes, abrasive scourers, or any sharp metal objects as they may damage the product.

Additionally, we recommend checking the components of the bed frame regularly to ensure that all screws are tightened and the frame remains stable.

Installing the bed frame is a simple process. Please refer to the detailed instructions in the manual for step-by-step guidance.

Customer satisfaction is our top priority and we are committed to providing you with the best service and high-quality products. If you have any questions or concerns regarding your bed frame, please don't hesitate to contact our customer service team at email. We are here to help you and resolve any issues you may have. To solve your problem faster, please note the following information in the email.

Theme: Beds Service

Content: Name-XXX

Order ID Number: xxx-xxxxxxx-xxxxxxx

Once again, we would like to express our gratitude to you for choosing our product. Your trust and support mean the world to us. We look forward to continuing to provide you with the best products and services possible.

Best Regards,

Customer Service Team

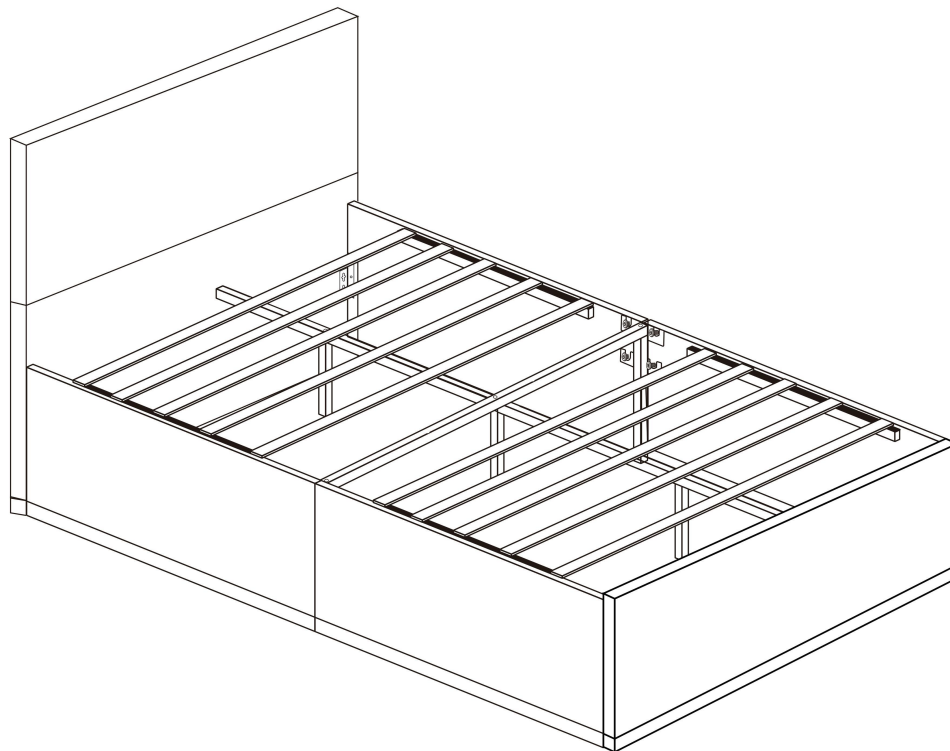

IMPORTANT NOTE



1. Please check that all parts are complete before installation.
2. Please strictly follow the installation steps to install.
3. Please install the bed on a clean and smooth surface to prevent any damage.
4. Please don't sit/stand/lie on the slats until the mattress is in place.
5. Please periodically check all the fittings and re-tighten as necessary.
6. Please do not use the bed unless all bolts and screw are firmly secured.
7. Please contact us if you need any help, we will reply you as soon as possible

Important tips:

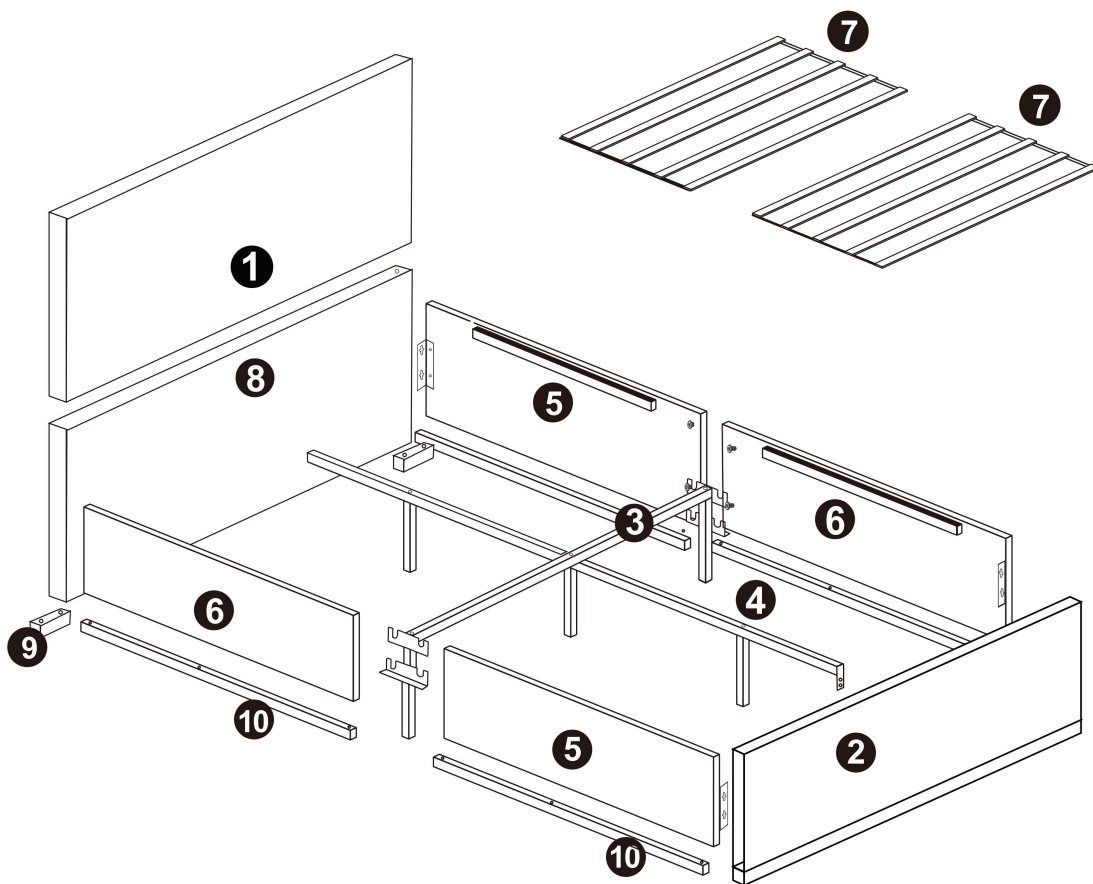

Don't tighten the screws first, make sure all parts are installed before tightening the screws.

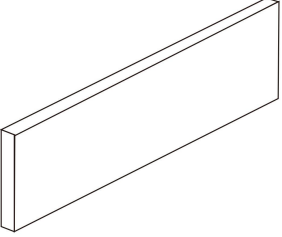
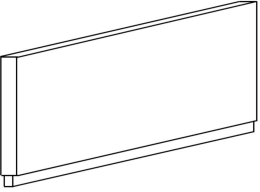
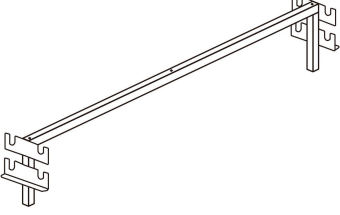
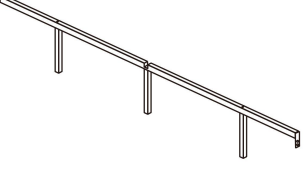
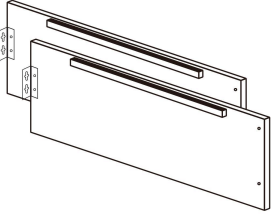
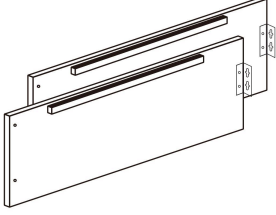
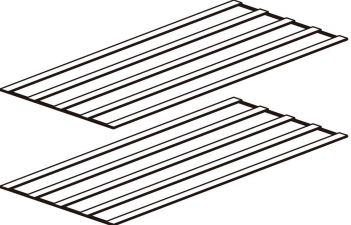
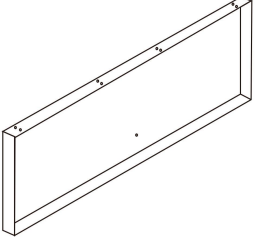

PART LIST

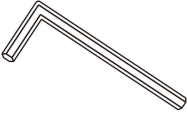
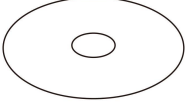

<p>(1) Upper headboard x 1pcs</p> 	<p>(2) Footboard x 1pcs</p> 	<p>(3) Transverse centerx 1 pcs</p> 
<p>(4) Center support bar x 1 pcs</p> 	<p>(5) Side panel x 2pcs</p> 	<p>(6) Bed Foot x 2 pcs</p> 
<p>(7) Slat x 2pcs</p> 	<p>(8) Lower headboard x 1pcs</p> 	<p>(9) Slat x 2pcs</p> 
<p>(10) Slat x 4pcs</p> 		

PART LIST

<p>(H4) Bolt M8x25mm x8pcs</p>  <p>(H2) Bolt M8x45mm x 18pcs</p>  <p>Bolt M8x35mm x 4pcs</p>  <p>(H1)</p> <p>Bolt M8x25mm Spare parts x 1pcs Bolt M8x35mm Spare parts x 1pcs Bolt M8x45mm Spare parts x 1pcs</p>	<p>(H3) Allen Key M8 x1pc (Installation tool)</p> 	<p>Screw washers</p> 
---	---	--

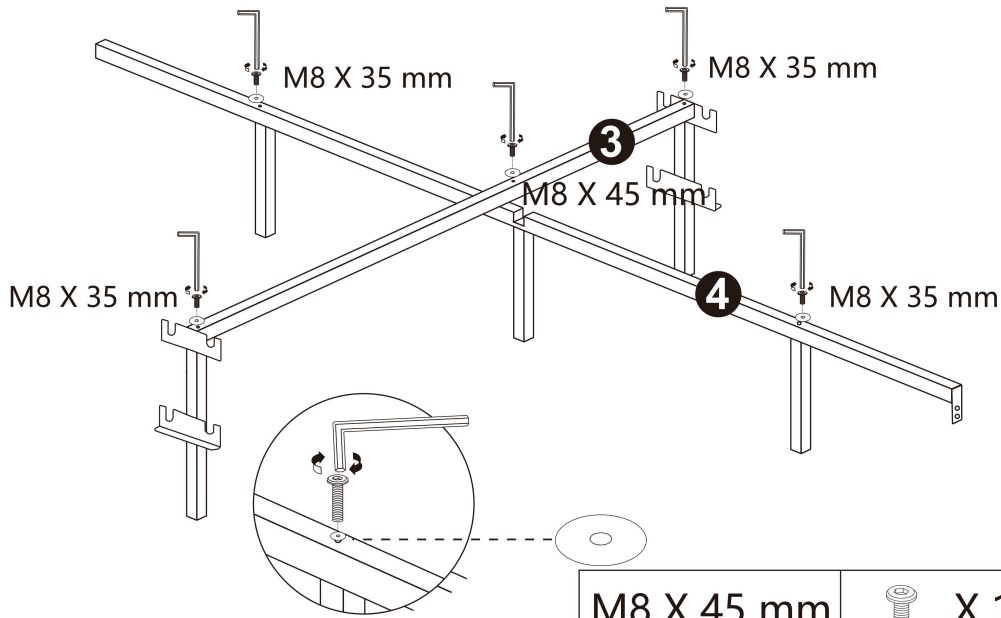
Step 1 Place part (4) directly beneath part (3), then tighten the assembly using the screws and washers shown in the diagram.



		M8 X 45 mm		X 1	
Screw washers		X 5	M8 X 35 mm		X 4

Step 2 Connect part (2) to part (4)

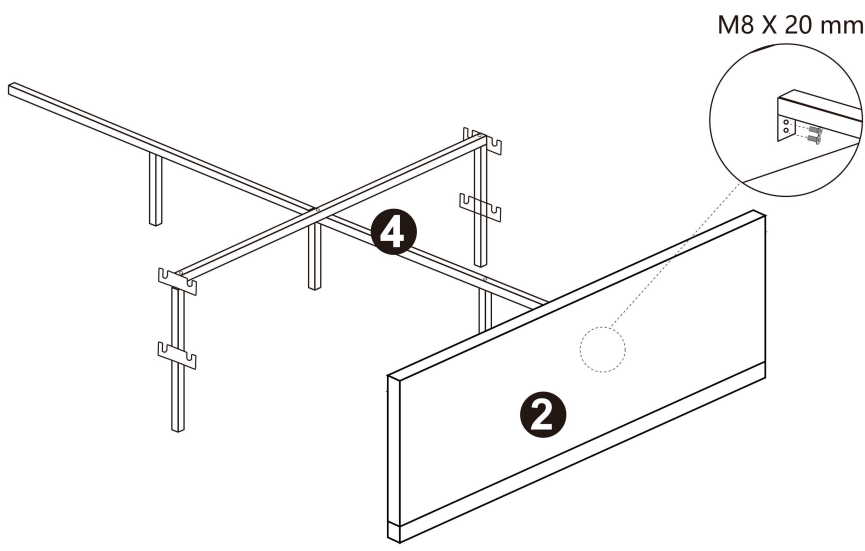

Translation:

Note: The M8 x 20mm screws are already pre-installed.

Step 3 Install part (10) at the bottom of part (5) and part(6)

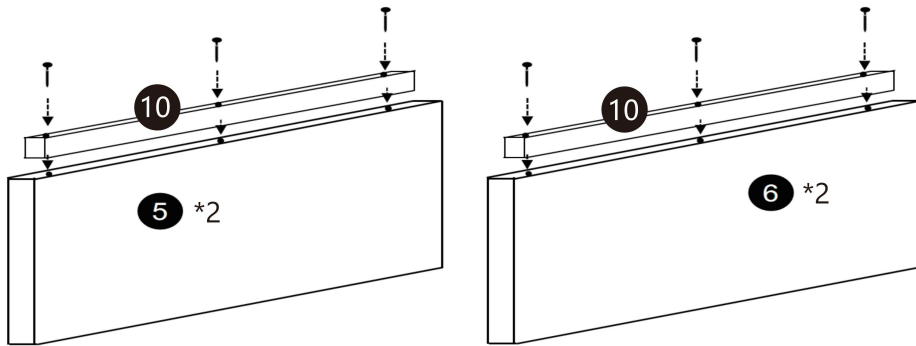

M8 X 45mm



X 12

Step 4 Install the components completed in step 3 onto part (3) and part(2).
Secure all connections with the corresponding screws according to the diagram.

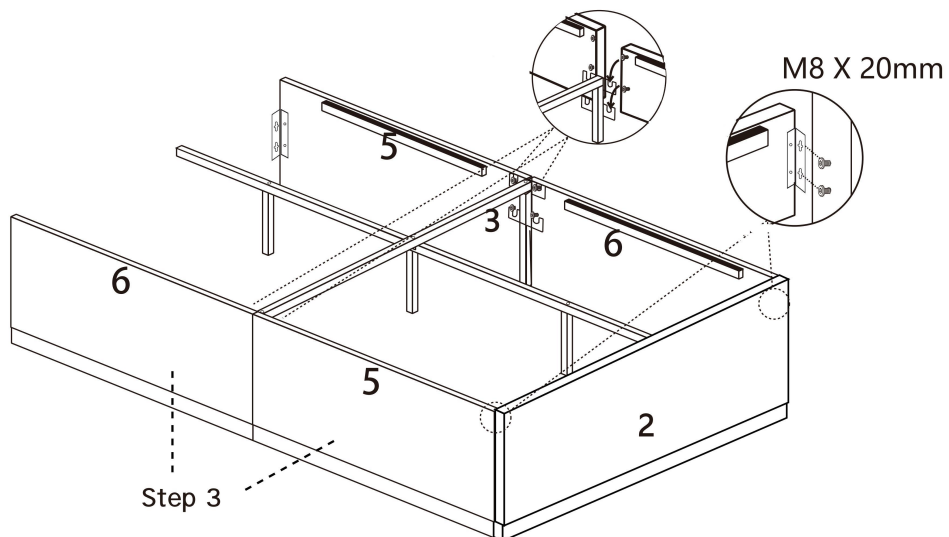

Translation:

Note: The M8 x 20mm screws are already pre-installed.

Step 5 Please install part (9) to part (8) separately

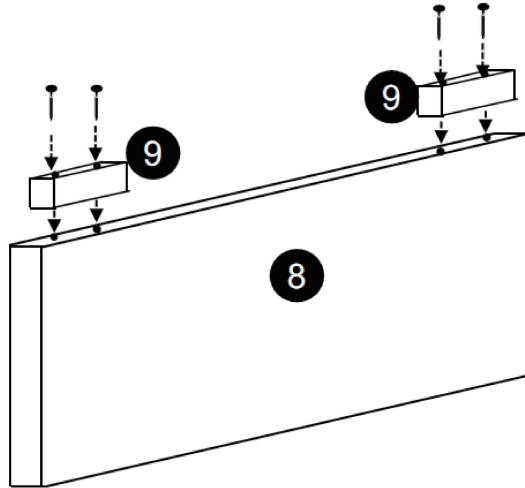

M8 X 45mm



X 4

Step 6 Install the components completed in step 5 onto part(4), as well as part (5) and part(6).

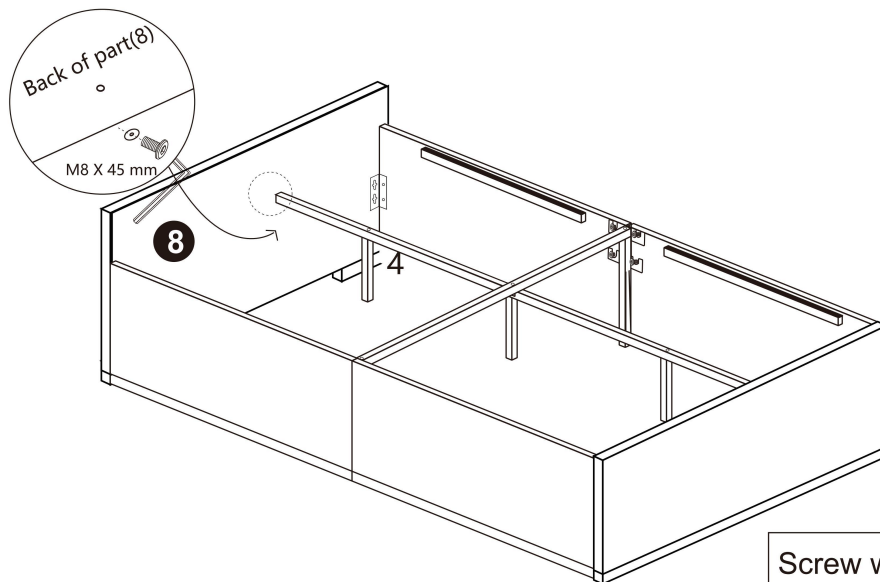

Screw washers



X 1



M8 X 45mm

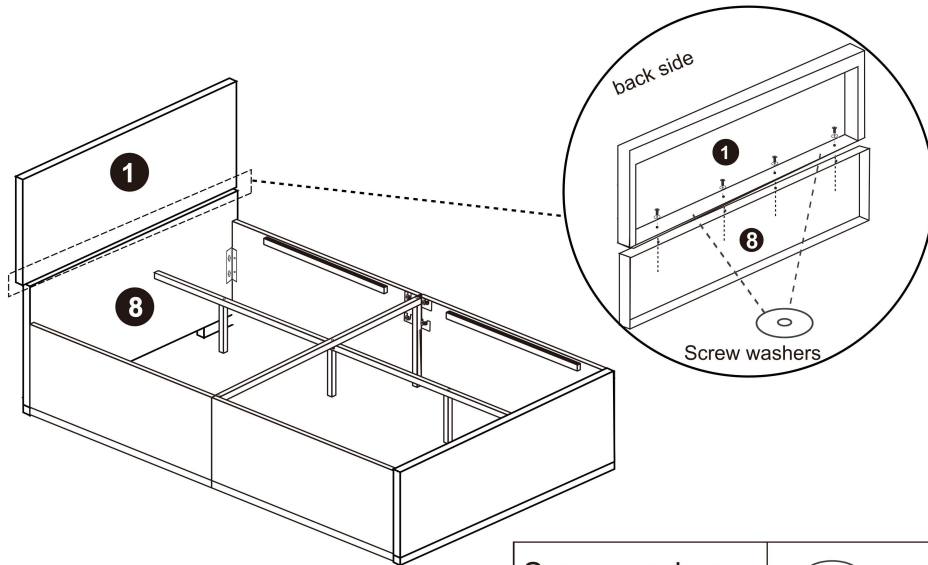

X 1

Step 7 Connect components 1 and 8. Secure all connections with corresponding screws and Screw washers.



Screw washers		X 8
M8 X 25mm		X 8

Step 8 Tighten all screws and place the slats (7) on.

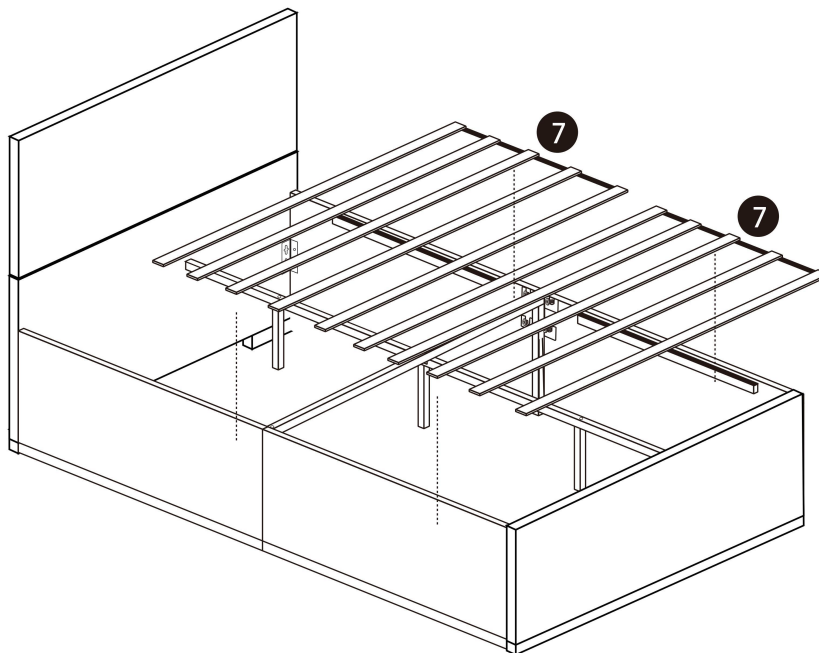

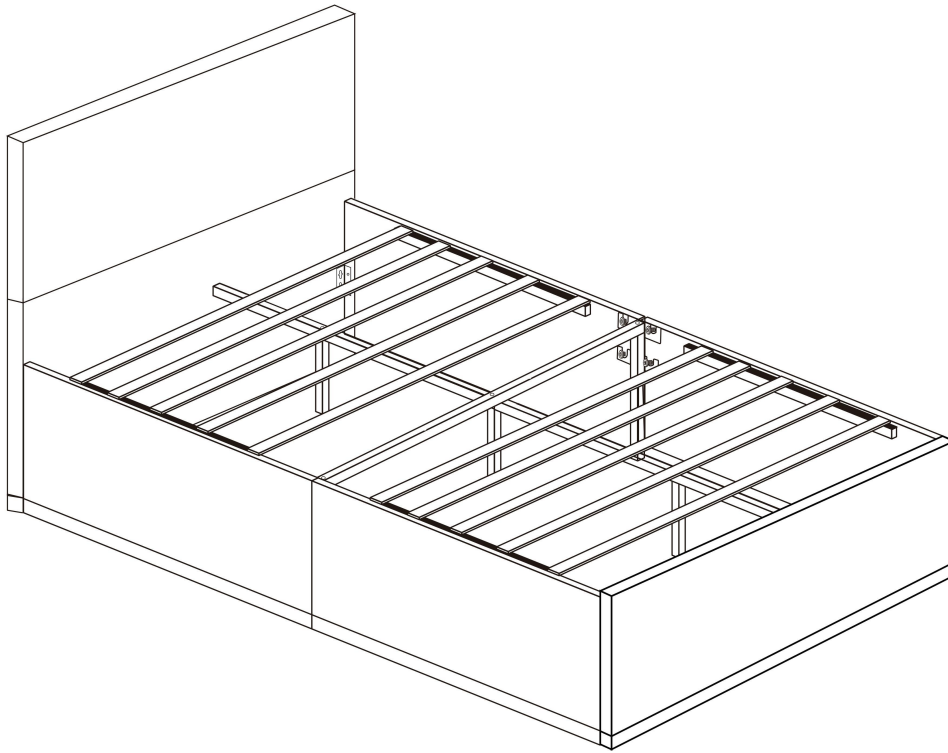

Job complete!

In the interest of our environment, please dispose
of all packaging thoughtfully, thanks!