

ASSEMBLY INSTRUCTION ROUND SUNBED

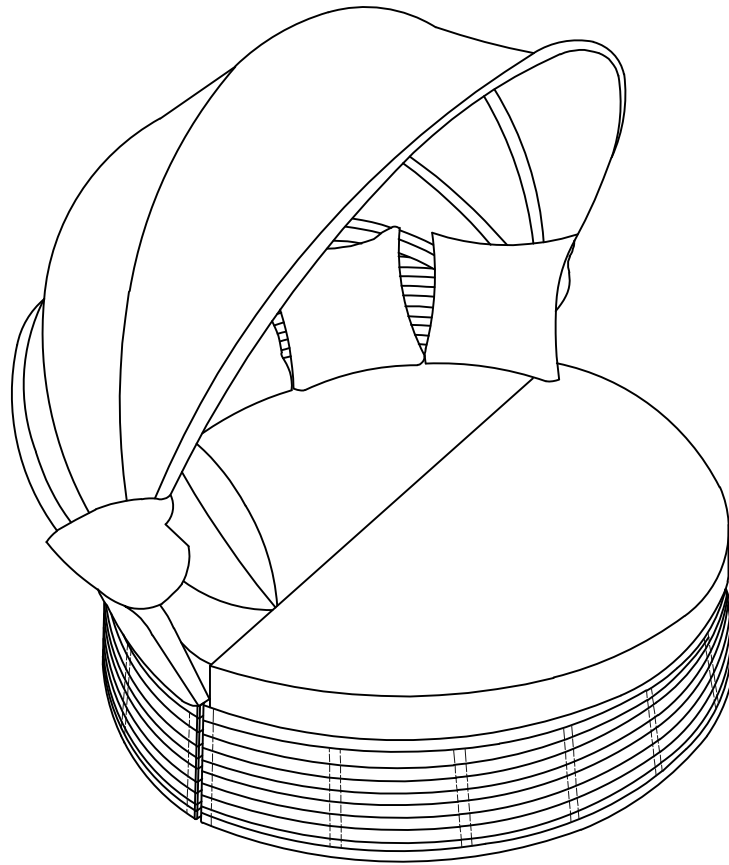

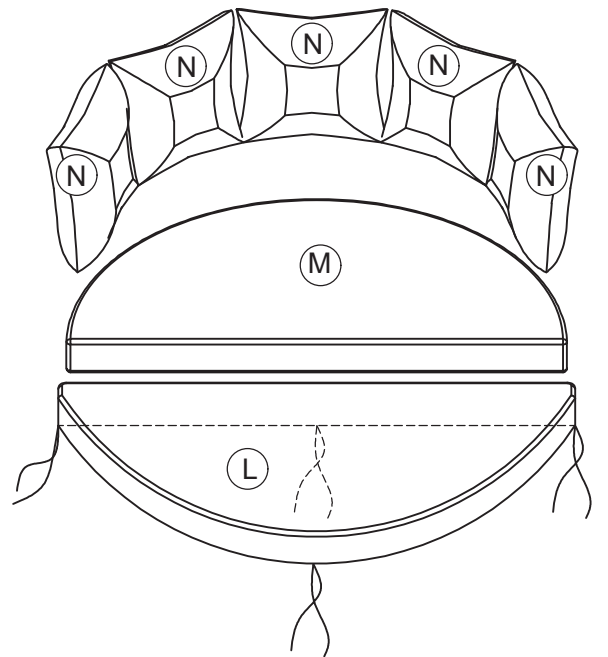

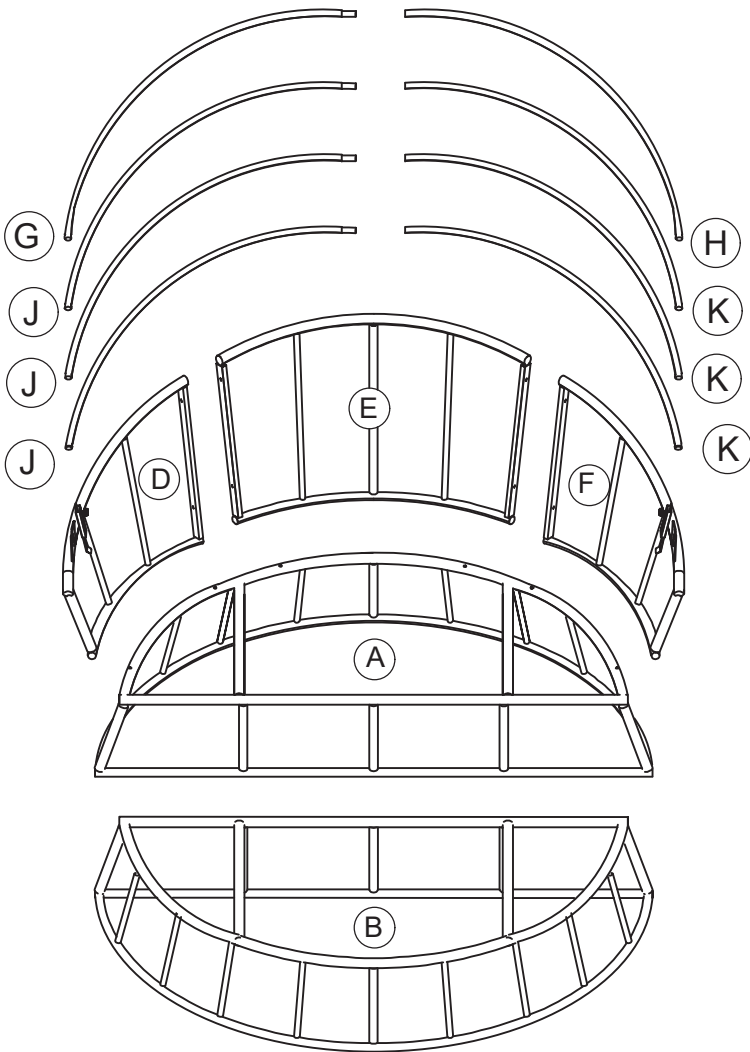
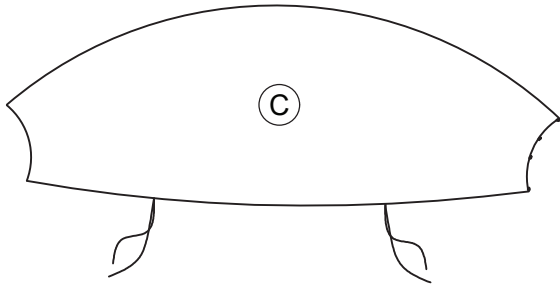

Notice

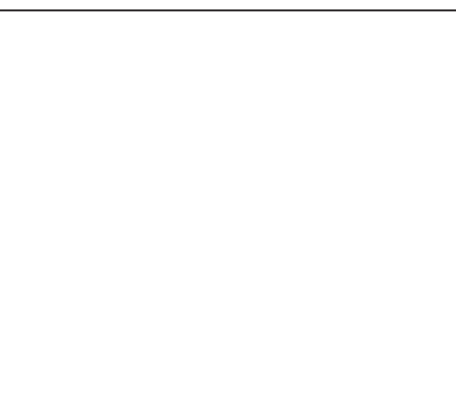
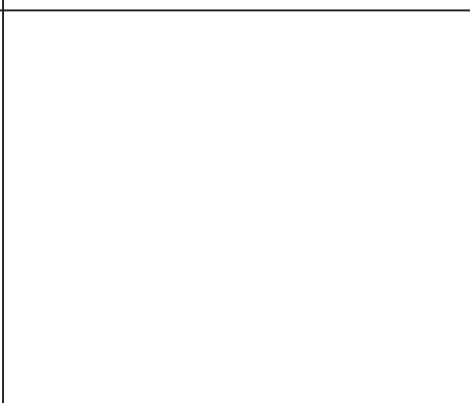
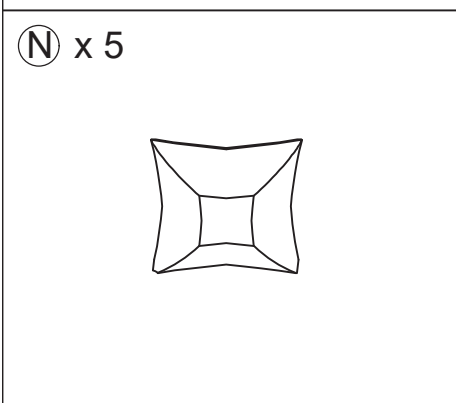
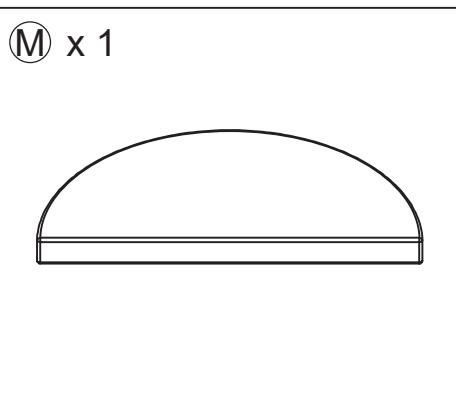
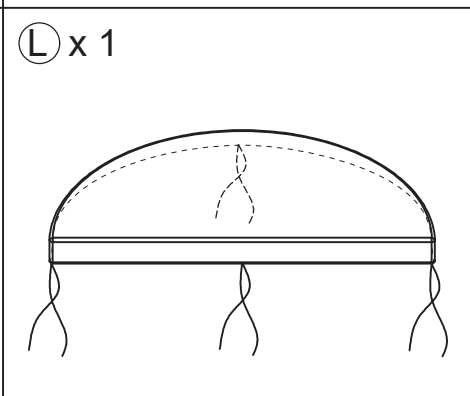
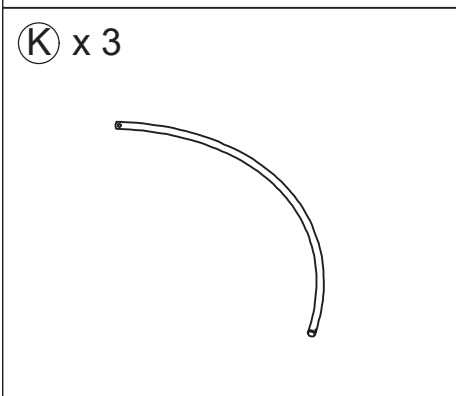
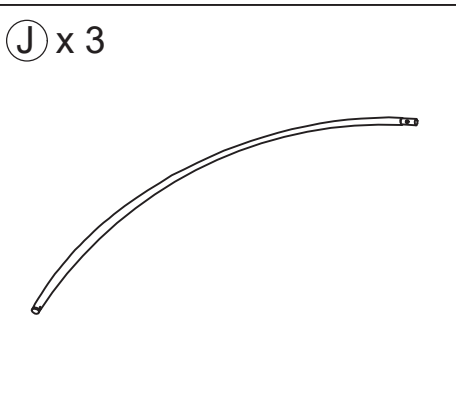
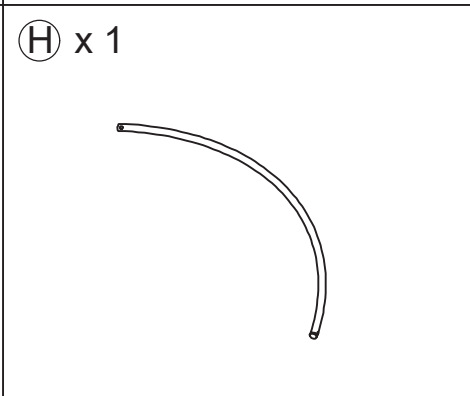
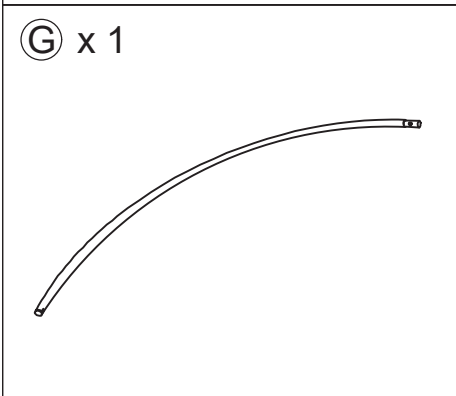
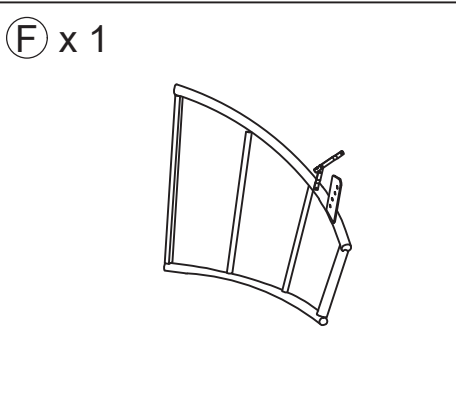
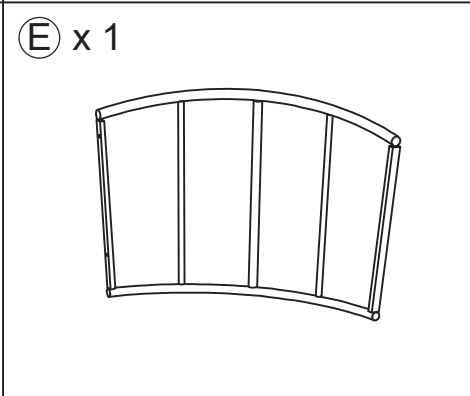
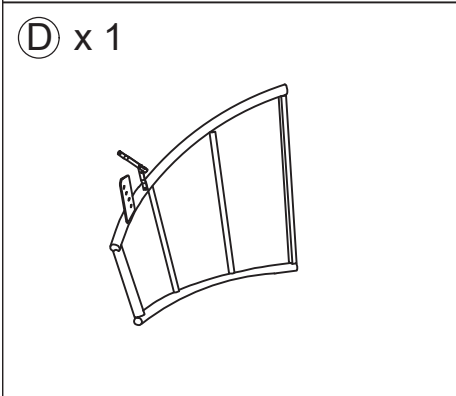
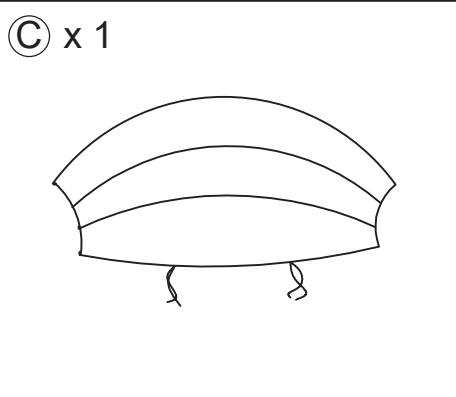
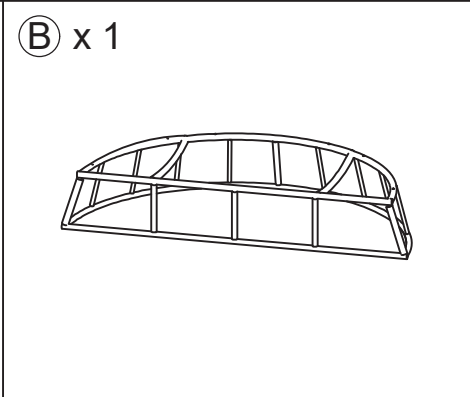
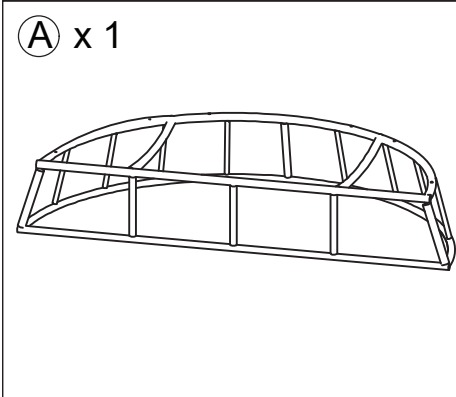
- 1. 50% Tighten before fixings all screws, Allen wrench is recommended instead of an electric drill.**
- 2. Place the item on a flat ground to adjust and make sure it remains stable.**
- 3. Tighten up all screws with tools gradually.**
- 4. If the screws are not aligned with holes during assembly, please loosen all the other screws to 50% and continue the assembly process.**
- 5. If the item is not stable, please loosen all the screws, adjust it on a flat ground and tighten up all screws again.**
- 6. Note: If one or more screws are fully tightened during assembly, chances are the others will not be aligned with holes. In addition, all the holes are designed to be relatively larger to provide more space for the adjustment of the screws.**

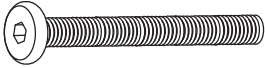
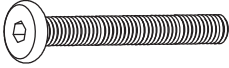
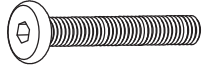
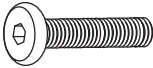
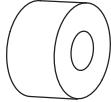

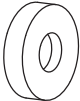

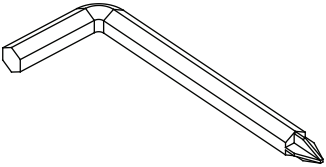
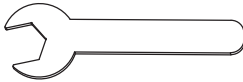
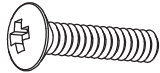
<p>①</p>  <p>Bolt M6x50mm 6pcs + 1pc</p>	<p>②</p>  <p>Bolt M6x40mm 4pcs + 1pc</p>	<p>③</p>  <p>Bolt M6x30mm 8pcs + 1pc</p>
<p>④</p>  <p>Bolt M6x25mm 2pcs + 1pc</p>	<p>⑤</p>  <p>Plastic washer 6*16*10mm 2pcs + 1pc</p>	<p>⑥</p>  <p>Washer 6x16x1mm 28pcs + 2pcs</p>
<p>⑦</p>  <p>Plastic washer 6*16*5mm 8pcs + 1pc</p>	<p>⑧</p>  <p>Plastic foot 14pcs</p>	<p>⑨</p>  <p>Nut M6 8pcs + 1pc</p>
<p>⑩</p>  <p>Allen Wrench & Phillips Head Screw Driver 2pcs</p>	<p>⑪</p>  <p>Spanner 1pc</p>	<p>⑫</p>  <p>Bolt M4x10mm 4pcs + 1pc</p>

Step 1

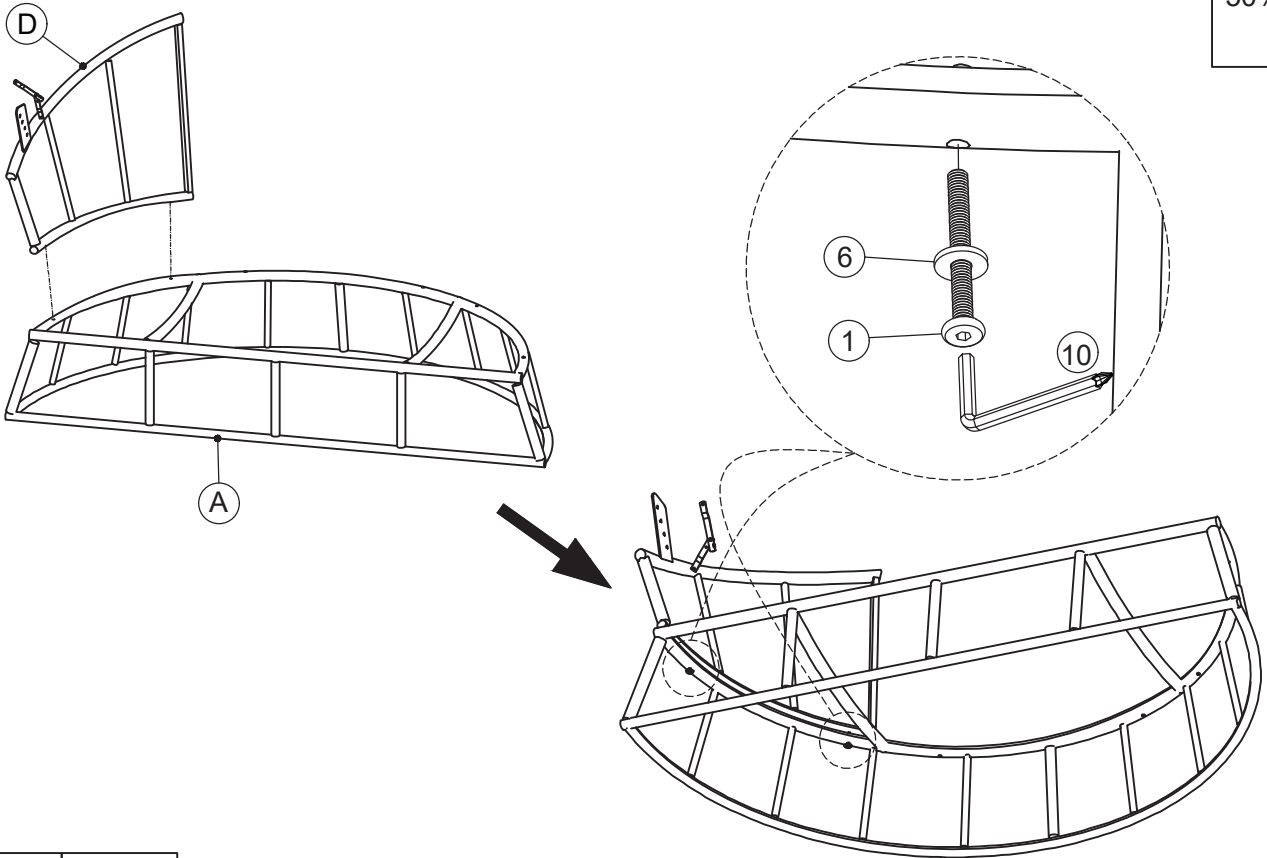
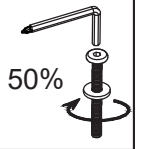

① x 2

⑥ x 2

Step 2

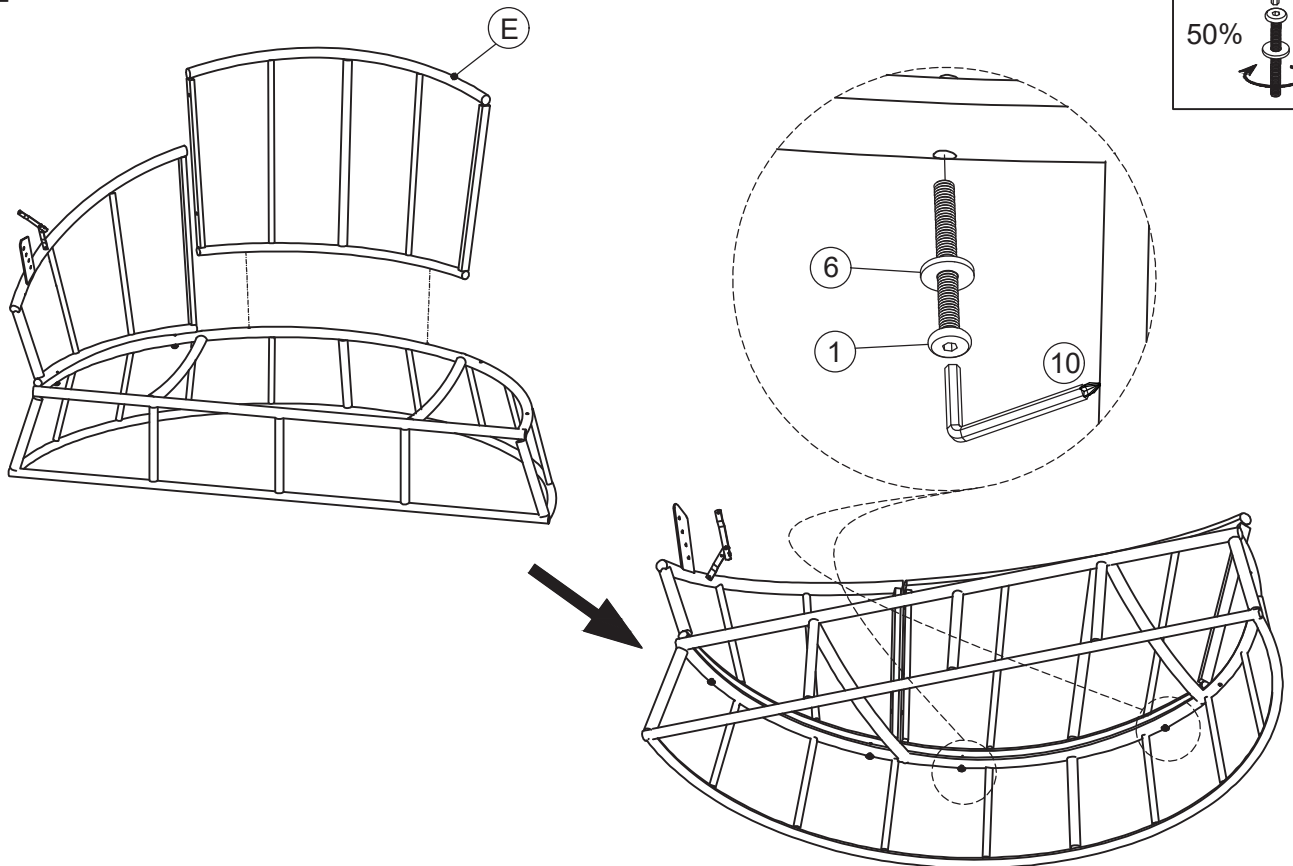
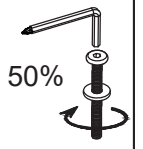

① x 2

⑥ x 2

Step 3

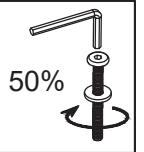
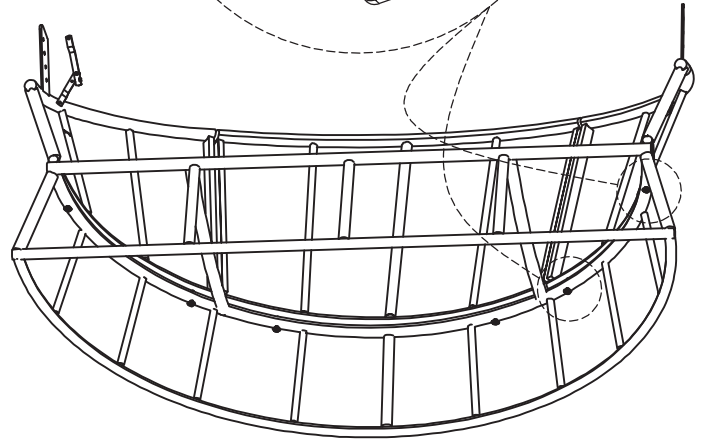
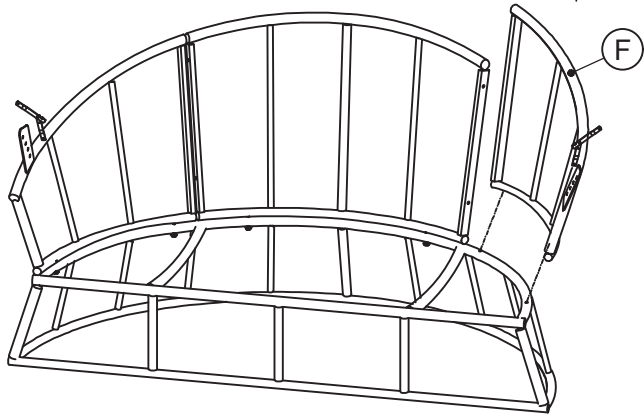

1 x 2

6 x 2

Step 4

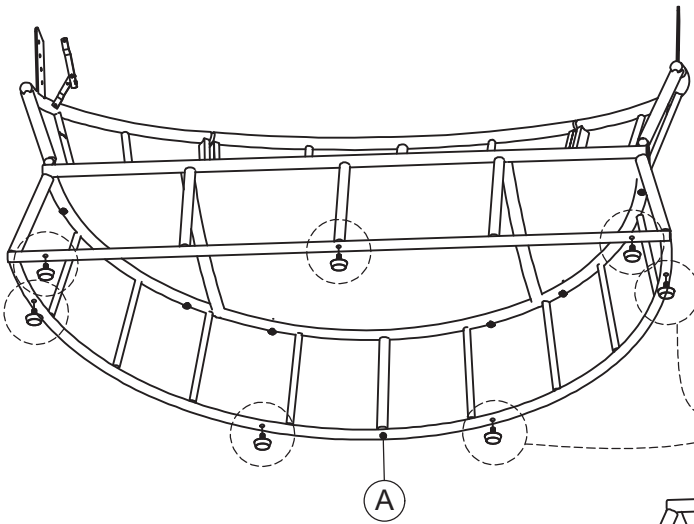

A

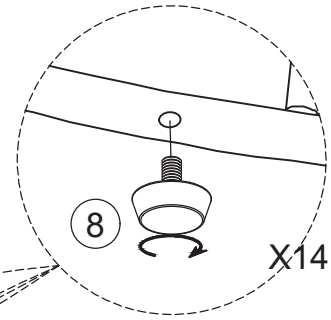

8

X14

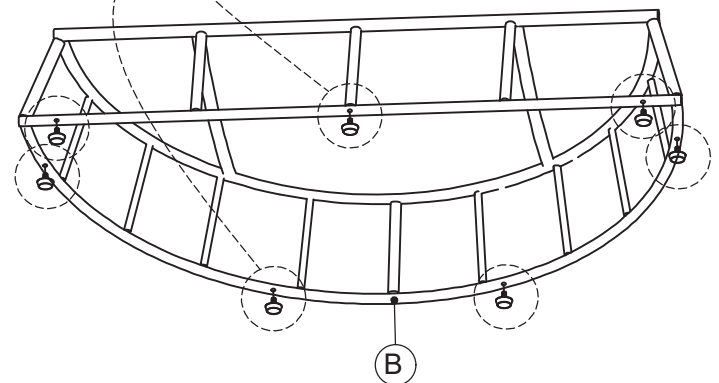

B

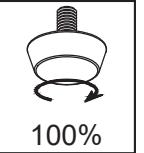

7 x 14

Step 5

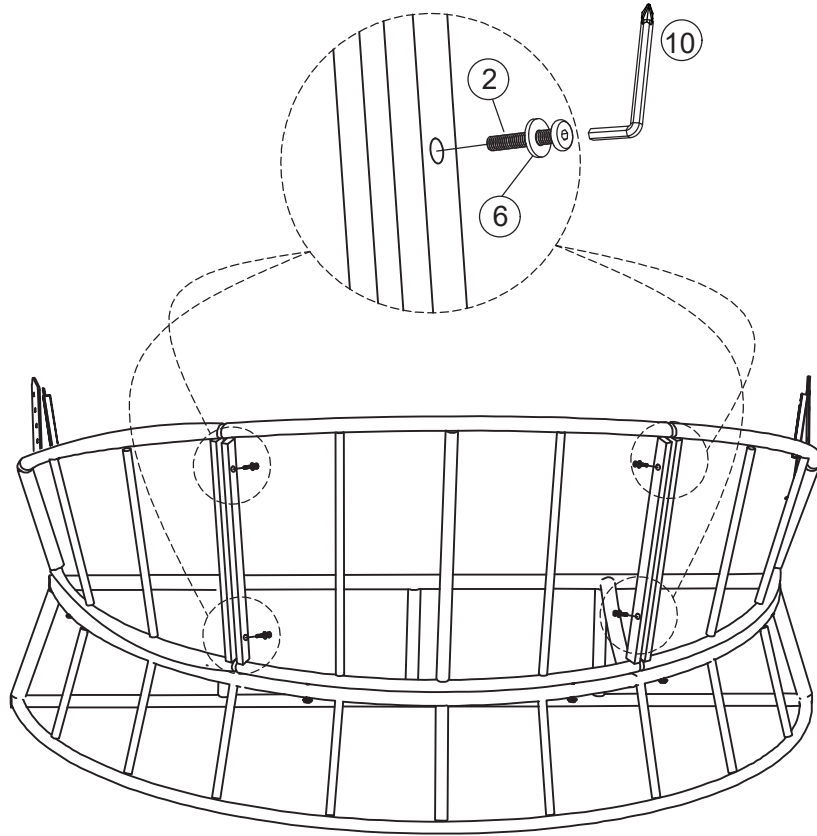
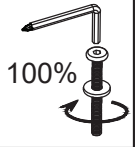

② x 4

⑥ x 4

Step 6

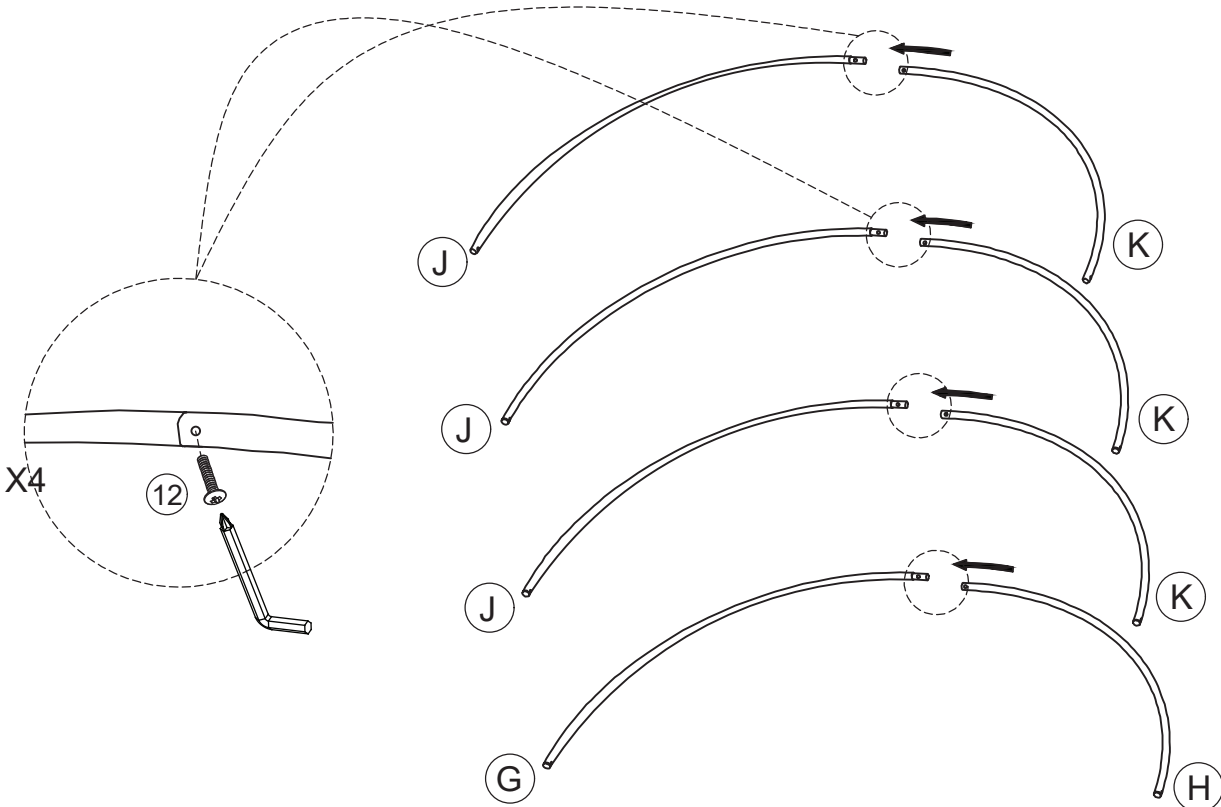
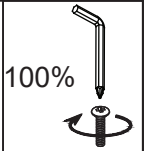

⑫ x 4

Step 7

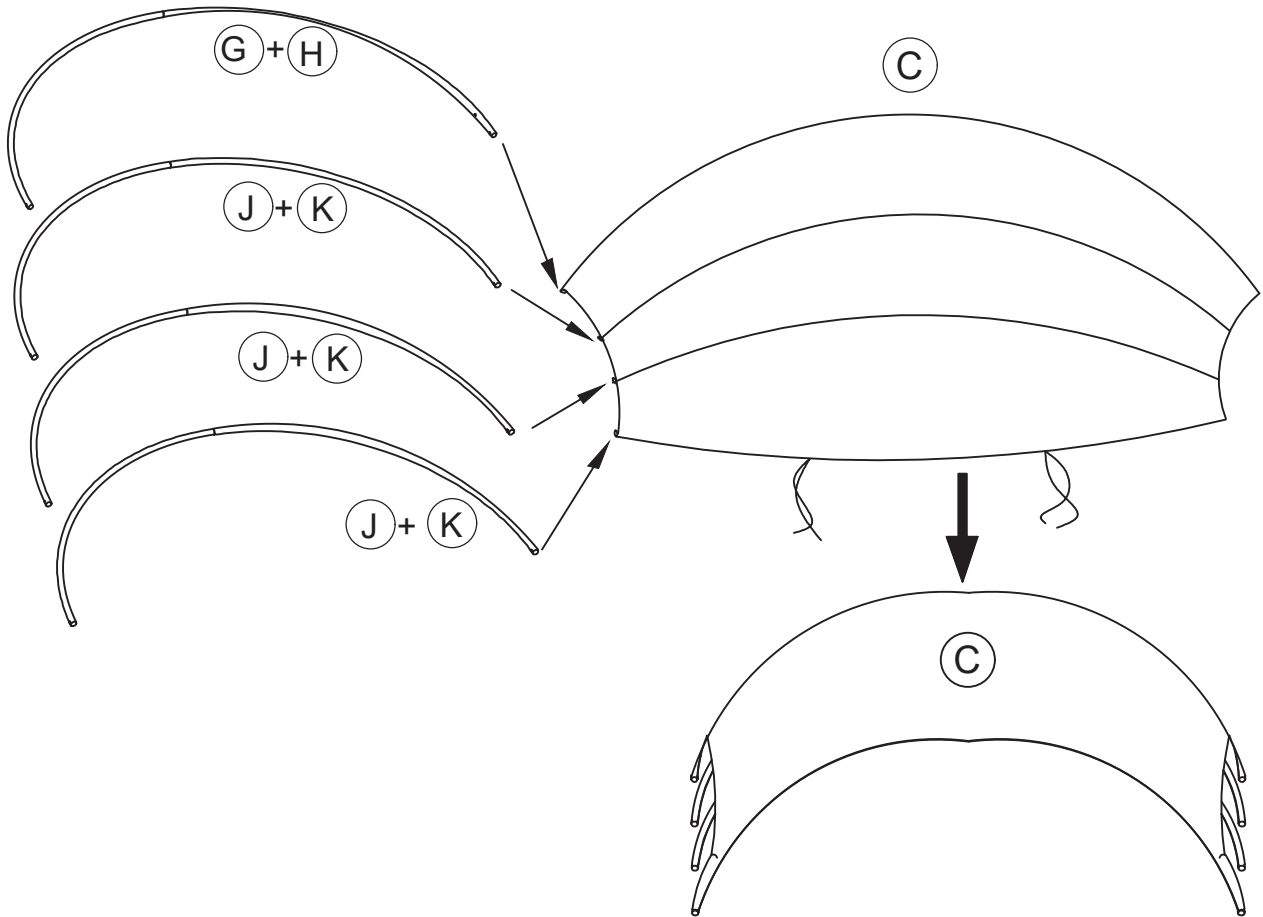

Step 8

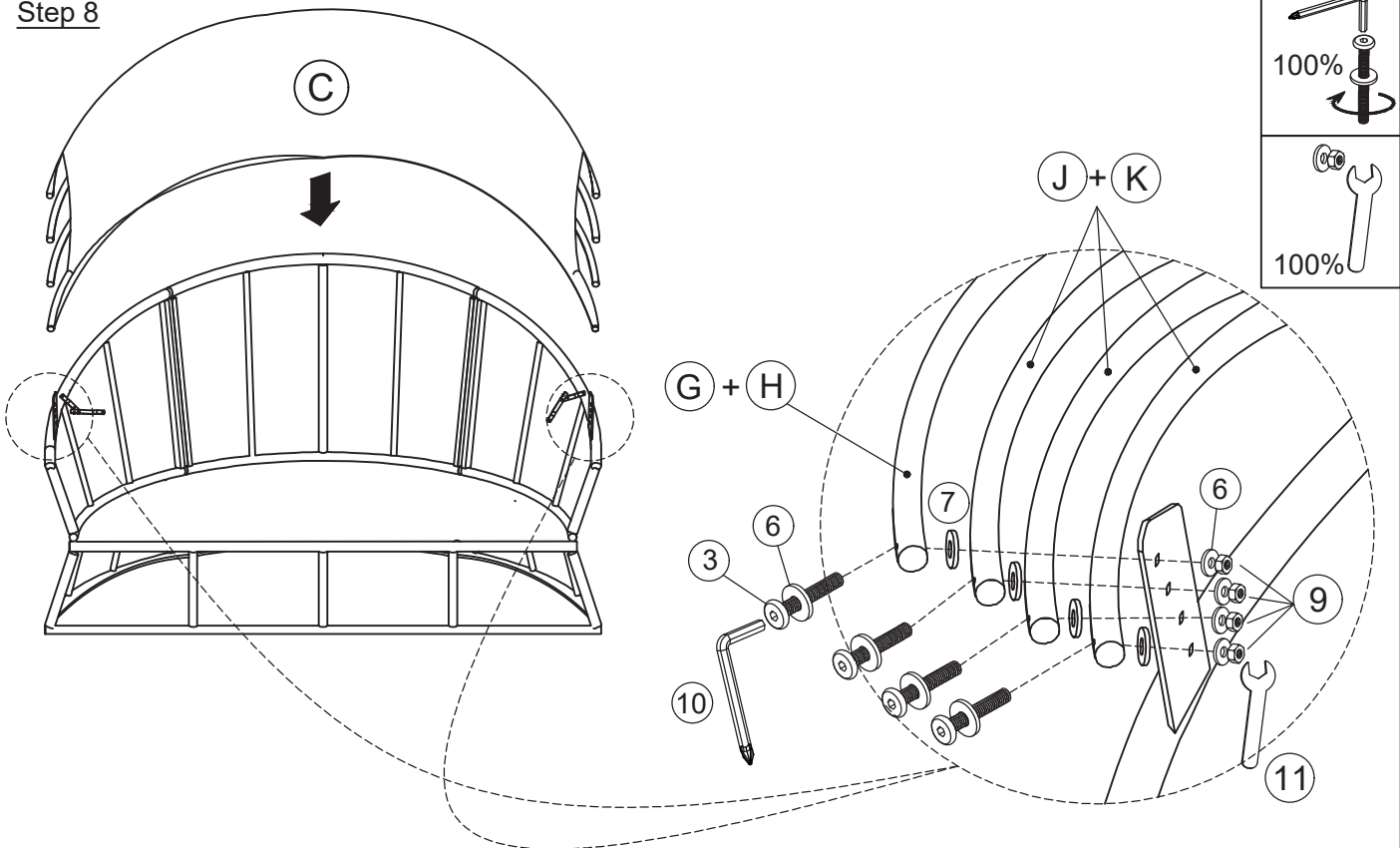

- | | | | |
|-------|--------|-------|-------|
| ③ x 8 | ⑥ x 16 | ⑦ x 8 | ⑨ x 8 |
|-------|--------|-------|-------|

Step 9

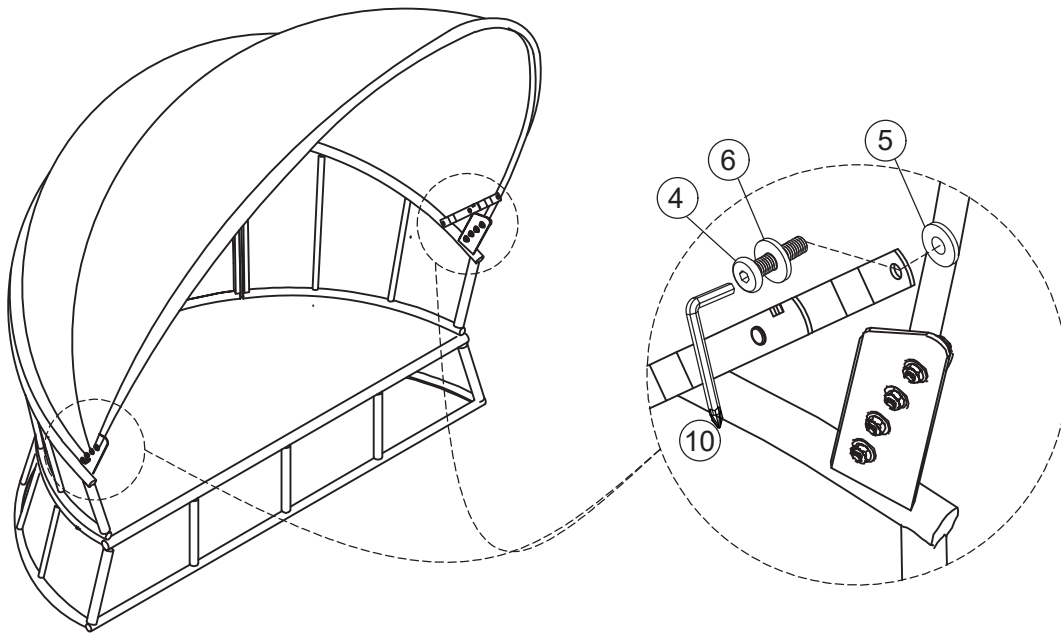
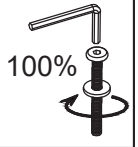

- ④ x 2
- ⑤ x 2
- ⑥ x 2

Step 10

