

Installation Manual

Assembly Instructions - Please keep for future reference

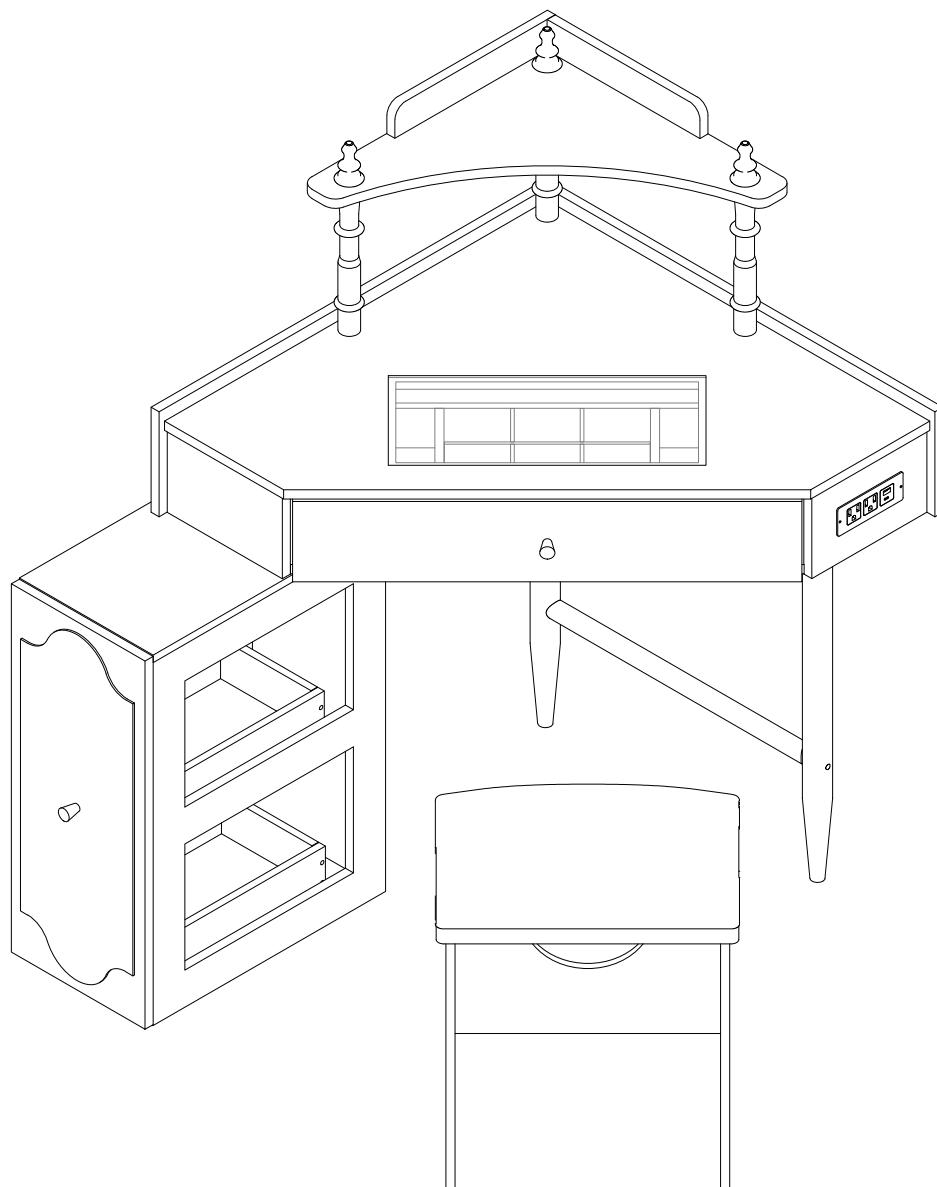

Important – Please read these instructions fully before starting assembly

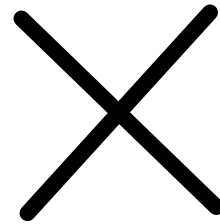
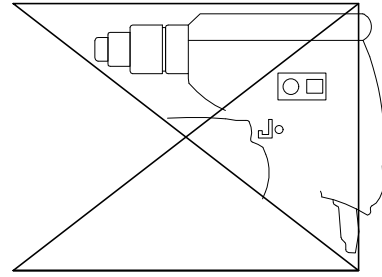
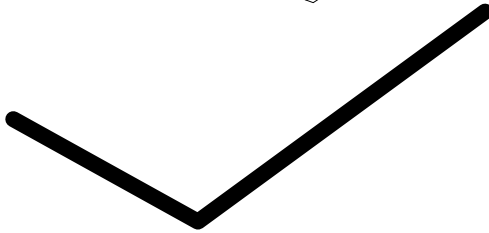
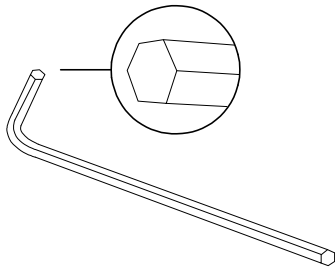

(DE): Verwenden Sie beim Anbringen der Tischplatte keinen Bohrer! Bitte verwenden Sie die im Paket enthaltenen Werkzeuge.

(UK): Do not use an electric drill when installing the desktop! Please use the tools provided in the package.

(FR): Ne pas utiliser de perceuse électrique lors de l'installation du plateau de table ! Veuillez utiliser les outils fournis dans l'emballage.

(IT): Non utilizzare un trapano elettrico durante l'installazione del piano del tavolo! Si prega di utilizzare gli strumenti forniti nella confezione.

(ES): ¡No utilice un taladro eléctrico al instalar el escritorio! Por favor, use las herramientas incluidas en el paquete.

(NL): Gebruik geen elektrische boormachine bij het monteren van het tafelblad! Gebruik de meegeleverde gereedschappen uit de verpakking.

(SE): Använd inte en elektrisk bormaskin vid montering av bordsskivan! Använd de verktyg som medföljer i förpackningen.

(PL): Nie używaj wiertarki elektrycznej podczas montażu blatu! Użyj narzędzi dołączonych do opakowania.



Safety and Care Advice

Important – Please read these instructions fully before starting assembly

- Check you have all the components and tools listed on the following pages.
- Remove all fittings from the plastic bags and separate them into their groups.
- Keep children and animals away from the work area, small parts could choke if swallowed.
- Make sure you have enough space to layout the parts before starting.

- During assembly do not stand or put weight on the product, this could cause damage.
- Assemble the item as close to its final position (in the same room) as possible.
- Assemble on a soft level surface to avoid damaging the unit or your floor.
- Parts of the assembly will be easier with 2 people.



- To reduce the likelihood of damaging your product please ensure that your power drill is set on a low torque setting.

Care and maintenance

- Only clean using a damp cloth and mild detergent, do not use bleach or abrasive cleaners.
- From time to time check that there are no loose screws on this unit.
- This product should not be discarded with household waste. Take to your local authority waste disposal centre.

Handy Hints

- Assemble all parts and bolts loosely during assembly, only once the product is complete should you fully tighten the bolts
- Regularly check and ensure That all bolts and fittings are tightened properly.

WARNING In order to help prevent overturning – please follow these instructions

To help prevent product toppling over please follow the below steps:-

Use the anti tip strap or wall fixing method provided (if applicable)
Do not allow children to climb or hang on the furniture
Do not open more than one drawer at a time
Do not place heavy items in the top drawers
Do not place heavy items on top of the furniture, unless the furniture has been designed for this purpose

Please note that only the anti tip strap is provided.

You will need to provide wall plugs and screws applicable for your wall type

Using Camlocks

Step 1

Connect the male camlock as directed in the assembly instructions using a screwdriver.

1

DO NOT OVER TIGHTEN.
NE PAS SERRER EXCESSIVEMENT.

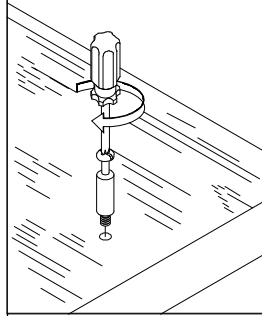

Step 2

Push the male camlock into the entry hole.

2

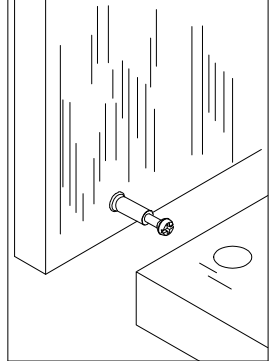

Step 3

Insert the female camlock as shown in the instruction.

Note: ensure that the arrow on the top of the camlock points towards the entry hole for the male camlock.

3

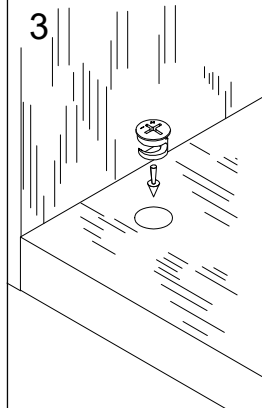

Step 4

Turn the female camlock clockwise with a screwdriver.

You should feel a click when the camlock is locked in place.

The joint is now secure.

4

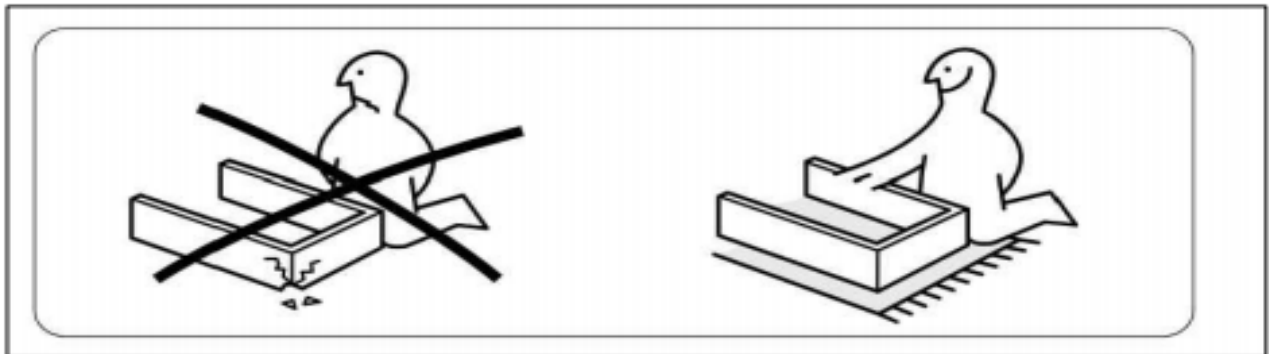
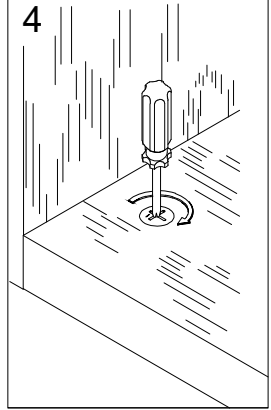

Make sure to put one carpet or some thicker film under the cabinet body during the installation in order to avoid scratch or damage to the parts.

EN It may be necessary to adjust the hinges so that the doors align. Use the instructions below as a guide.

FR Il est parfois nécessaire d'ajuster les charnières pour un meilleur alignement des portes. Servez-vous des instructions ci-dessous comme guide.

ES Puede que sea necesario ajustar los quicios de forma que se alineen las puertas. Use las instrucciones que aparecen debajo como guía.

DE Möglicherweise müssen Sie die Scharniere so einstellen, dass die Türen ausgerichtet sind. Verwenden Sie die nachstehenden Anweisungen als Leitfaden.

IT Potrebbe essere necessario regolare le cerniere in modo che le porte siano allineate. Per fare ciò attenersi alle istruzioni sottostanti.

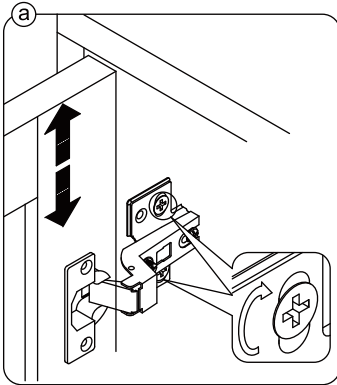

EN To adjust the door vertically loosen the screw as shown and move up and down as needed.

FR Si vous souhaitez régler la porte **verticalement**, desserrez la vis comme indiqué et déplacez la porte de haut en bas selon les besoins.

ES Para ajustar la puerta **verticalmente** afloje el tornillo tal y como se muestra y muévelo hacia arriba o hacia abajo según sea necesario.

DE Um die Tür **vertikal** auszurichten, lösen Sie die Schraube wie abgebildet und bewegen Sie sie nach Bedarf nach oben oder nach unten.

IT Per allineare la porta **verticalmente** allentare la vite come mostrato e spostarla in alto o in basso secondo necessità.

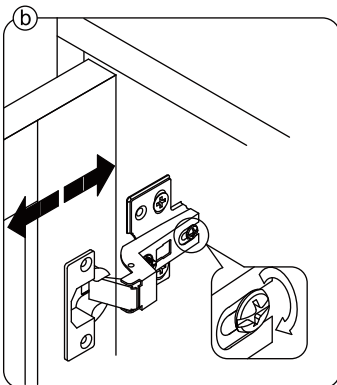

EN To adjust the gap from the door to the main frame turn the screw clockwise or anti-clockwise as needed.

FR Si vous souhaitez ajuster l'**écart** entre la porte et le cadre principal, tournez la vis dans le sens des aiguilles d'une montre ou dans le sens inverse, si nécessaire.

ES Para ajustar el **espacio** desde la puerta al marco principal, gire el tornillo en sentido horario o antihorario, según se necesite.

DE Um den **Abstand** von der Tür zum Hauptrahmen auszurichten, drehen Sie die Schraube je nach Bedarf im oder gegen den Uhrzeigersinn.

IT Per regolare lo **spazio** tra la porta e il telaio principale, avvitare o svitare la vite secondo necessità.

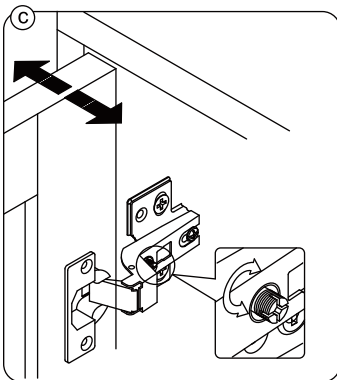

EN To adjust the door laterally adjust the screw as shown by turning clockwise or anti-clockwise.

FR Si vous souhaitez ajuster la porte **latéralement**, ajustez la vis comme indiqué en tournant dans le sens des aiguilles d'une montre ou dans le sens inverse des aiguilles d'une montre.

ES Para ajustar la puerta **lateralmente** ajuste el tornillo tal y como se muestra girándolo en sentido horario y antihorario.

DE Um die Tür **seitlich** auszurichten, stellen Sie bitte die Schraube wie abgebildet durch Drehen im oder gegen den Uhrzeigersinn ein.

IT Per allineare la porta **lateralmente** regolare la vite come mostrato, avvitarandola o svitarandola.

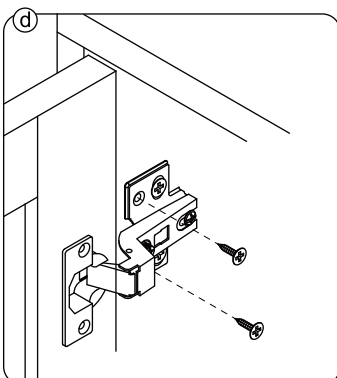

EN Please fix other screws

FR Merci de serrer les autres vis.

ES Fije los demás tornillos

DE Befestigen Sie bitte die anderen Schrauben

IT Fissare le altre viti

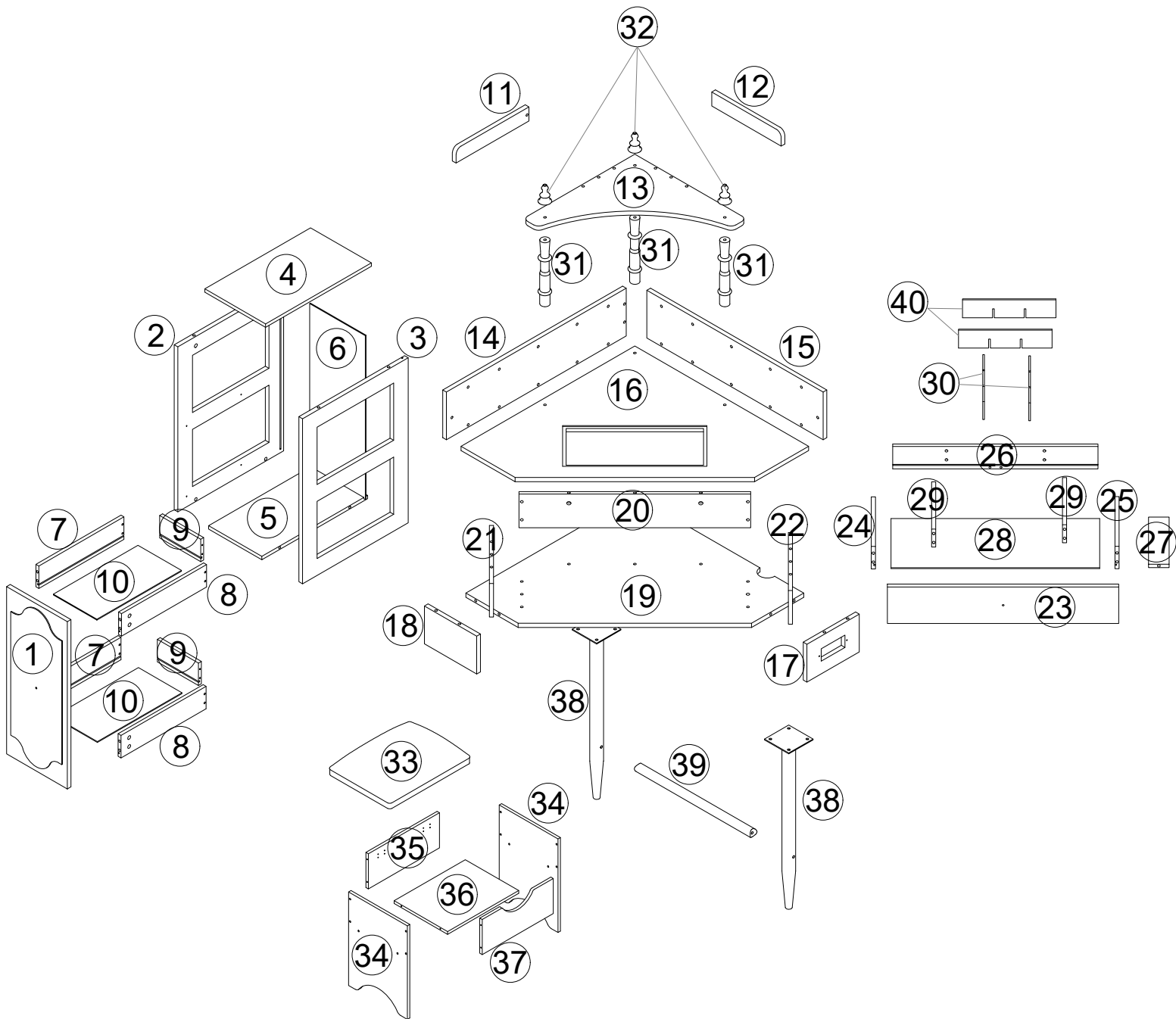

Assembly Instructions



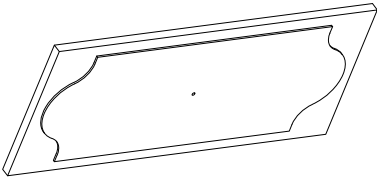
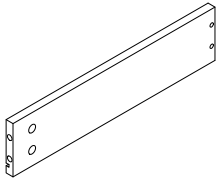
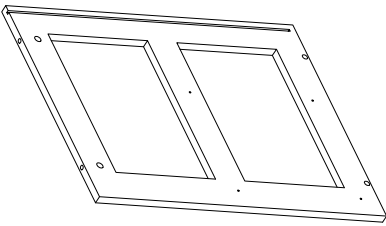
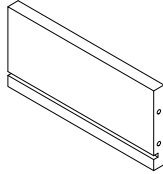
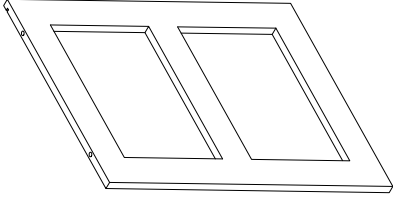
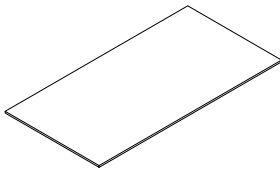
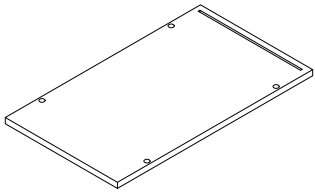
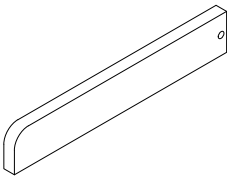
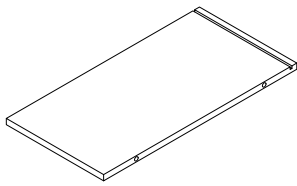
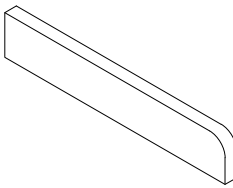
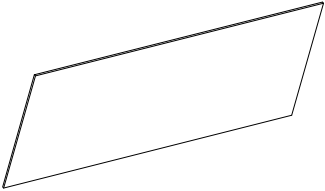
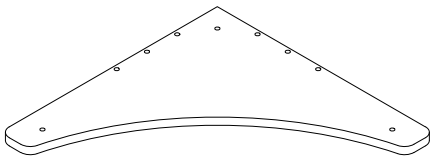
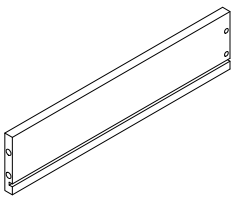
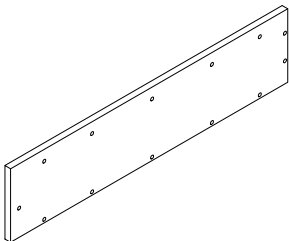

Assembly Instructions

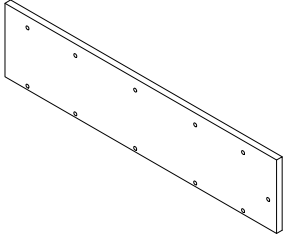
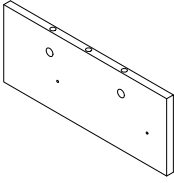
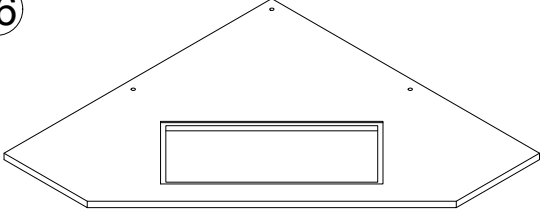
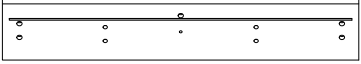
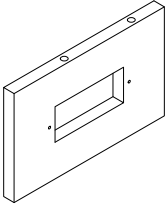
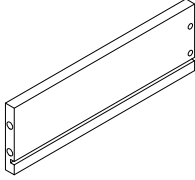
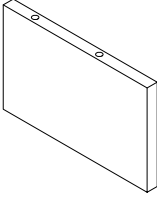
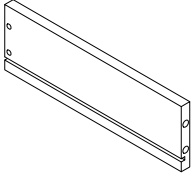
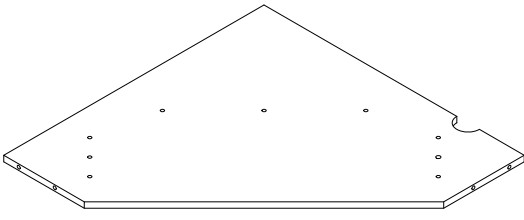
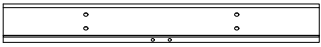
<p>①</p>  <p>1</p>	<p>⑧</p>  <p>2</p>
<p>②</p>  <p>1</p>	<p>⑨</p>  <p>2</p>
<p>③</p>  <p>1</p>	<p>⑩</p>  <p>2</p>
<p>④</p>  <p>1</p>	<p>⑪</p>  <p>1</p>
<p>⑤</p>  <p>1</p>	<p>⑫</p>  <p>1</p>
<p>⑥</p>  <p>1</p>	<p>⑬</p>  <p>1</p>
<p>⑦</p>  <p>2</p>	<p>⑭</p>  <p>1</p>

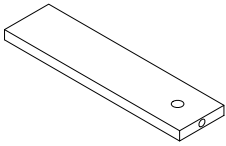
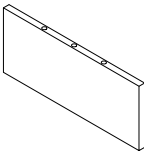
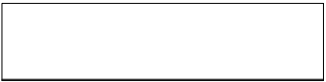
Assembly Instructions

<p>15</p>  <p>1</p>	<p>22</p>  <p>1</p>
<p>16</p>  <p>1</p>	<p>23</p>  <p>1</p>
<p>17</p>  <p>1</p>	<p>24</p>  <p>1</p>
<p>18</p>  <p>1</p>	<p>25</p>  <p>1</p>
<p>19</p>  <p>1</p>	<p>26</p>  <p>1</p>
<p>20</p>  <p>1</p>	<p>27</p>  <p>1</p>
<p>21</p>  <p>1</p>	<p>28</p>  <p>1</p>

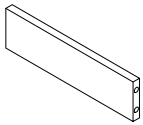
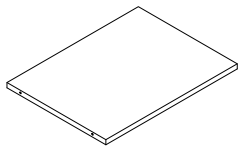
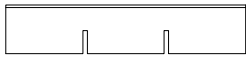
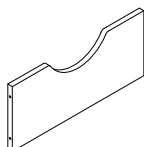
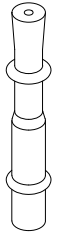

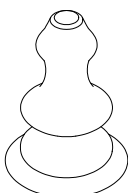
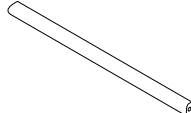
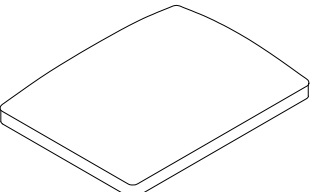
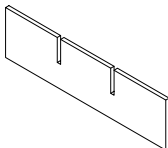
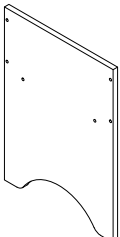
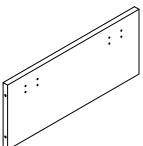





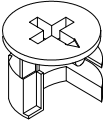
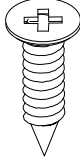

Assembly Instructions

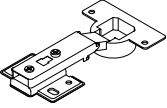
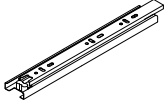
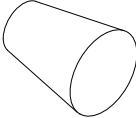
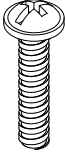
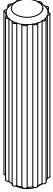
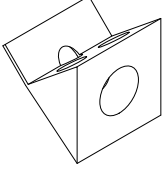
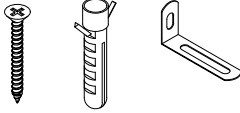
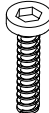
<p>29</p>  <p>2</p>	<p>36</p>  <p>1</p>
<p>30</p>  <p>2</p>	<p>37</p>  <p>1</p>
<p>31</p>  <p>3</p>	<p>38</p>  <p>2</p>
<p>32</p>  <p>3</p>	<p>39</p>  <p>1</p>
<p>33</p>  <p>1</p>	<p>40</p>  <p>2</p>
<p>34</p>  <p>2</p>	
<p>35</p>  <p>1</p>	

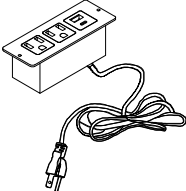
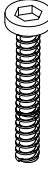
Components - Fittings

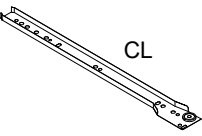
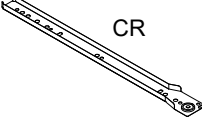
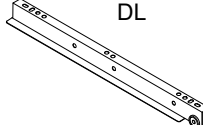
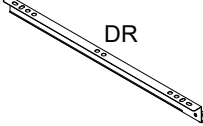
Please check you have all the parts listed below

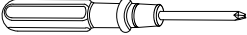

Note: The quantities below are the correct amount to complete the assembly. In some cases more fittings may be supplied than are required.

<p>A</p>  <p>x31</p>	<p>B</p>  <p>φ12 x31</p>	<p>C</p>  <p>M3.5*12mm x46</p>	<p>D</p>  <p>M6*40mm x43</p>
<p>E</p>  <p>x2</p>	<p>F</p>  <p>x2</p>	<p>G</p>  <p>x2</p>	<p>H</p>  <p>M4*18mm x2</p>
<p>I</p>  <p>φ8 x28</p>	<p>J</p>  <p>x6</p>	<p>K</p>  <p>x2</p>	<p>L</p>  <p>M6*30mm x3</p>
<p>M</p>  <p>M4*35mm x14</p>	<p>N</p>  <p>x1</p>	<p>O</p>  <p>M6*60mm x2</p>	<p>P</p>  <p>M6*12mm x8</p>
<p>CL</p>  <p>x2</p>	<p>CR</p>  <p>x2</p>	<p>DL</p>  <p>x2</p>	<p>DR</p>  <p>x2</p>
<p>Q</p>  <p>x3</p>			

Assembly Instructions

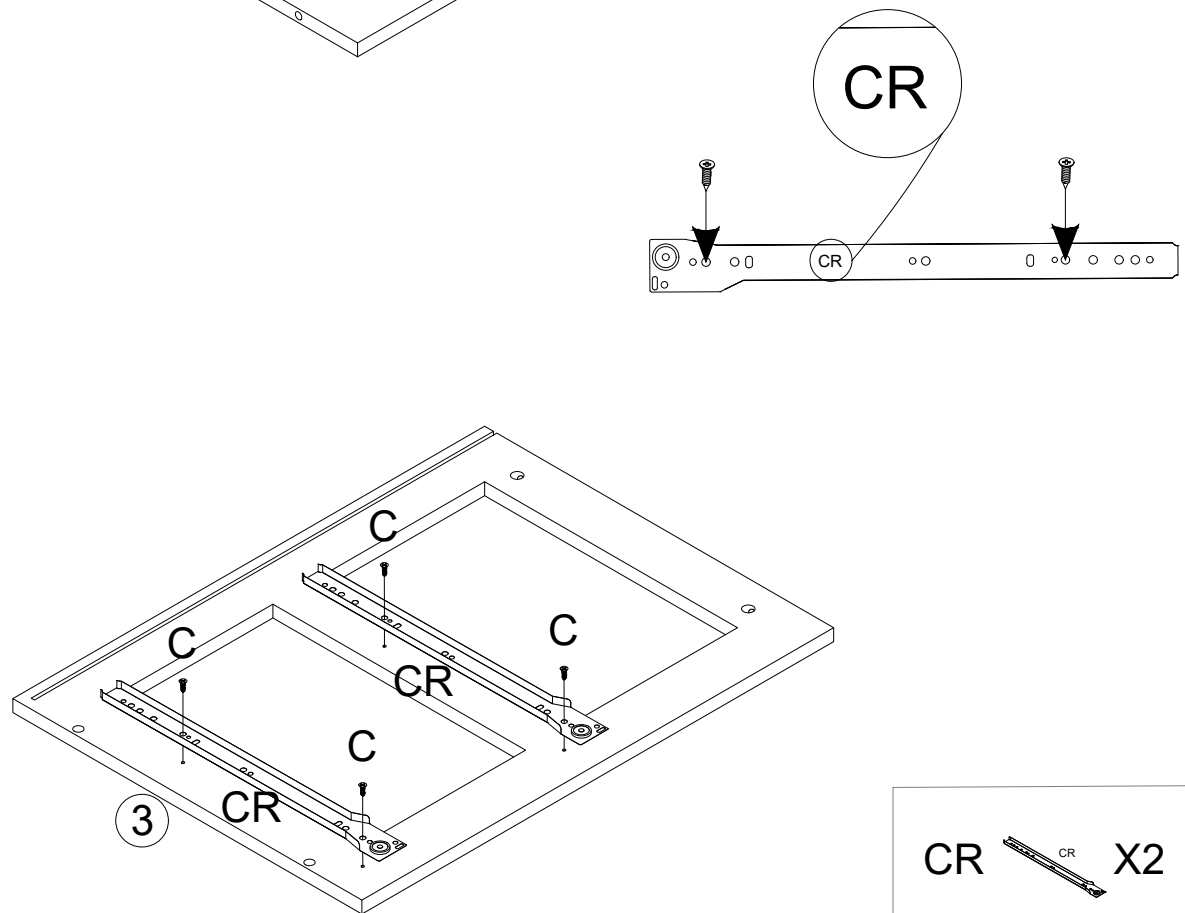
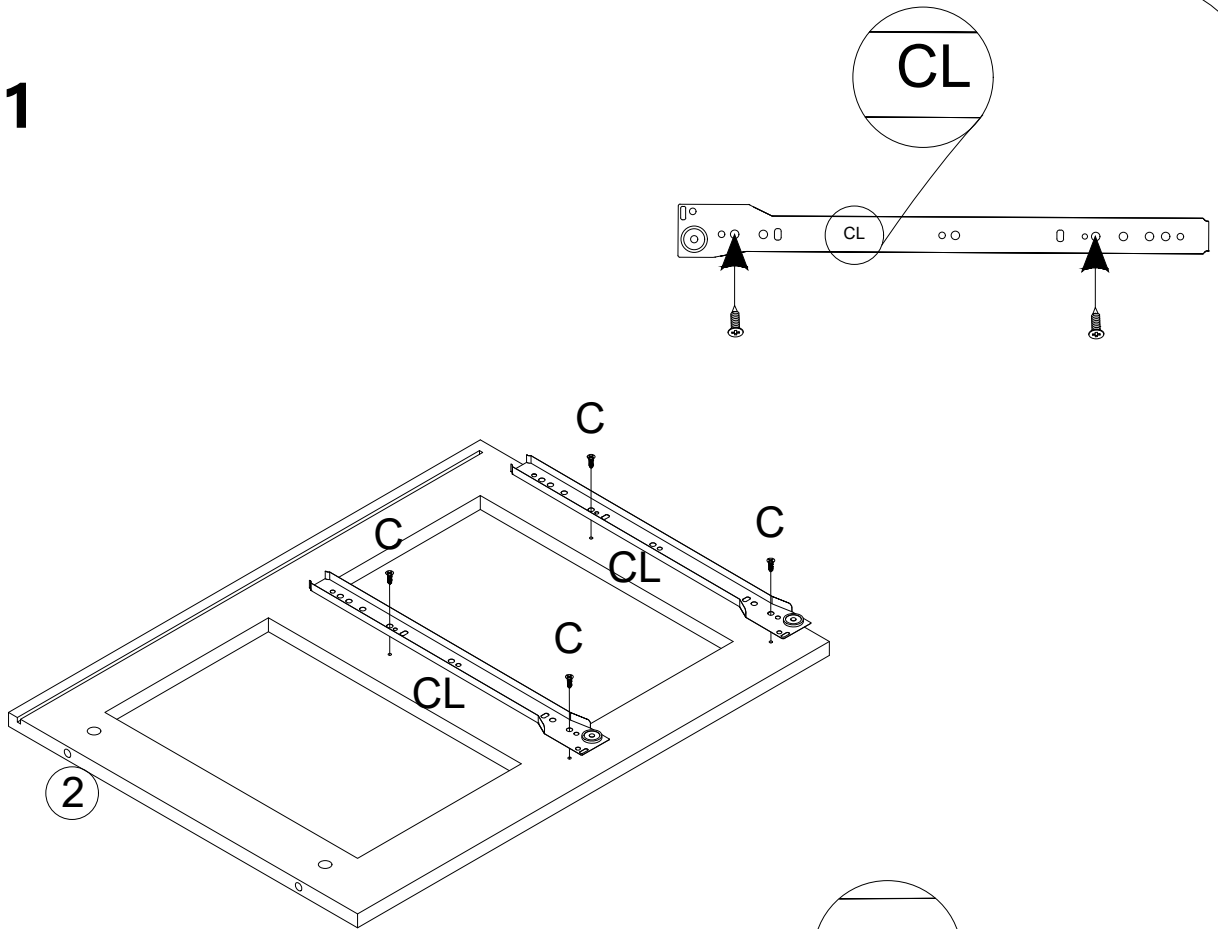
Step 1

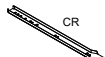

CR		X2
CL		X2
C		X8

Assembly Instructions

Step 2

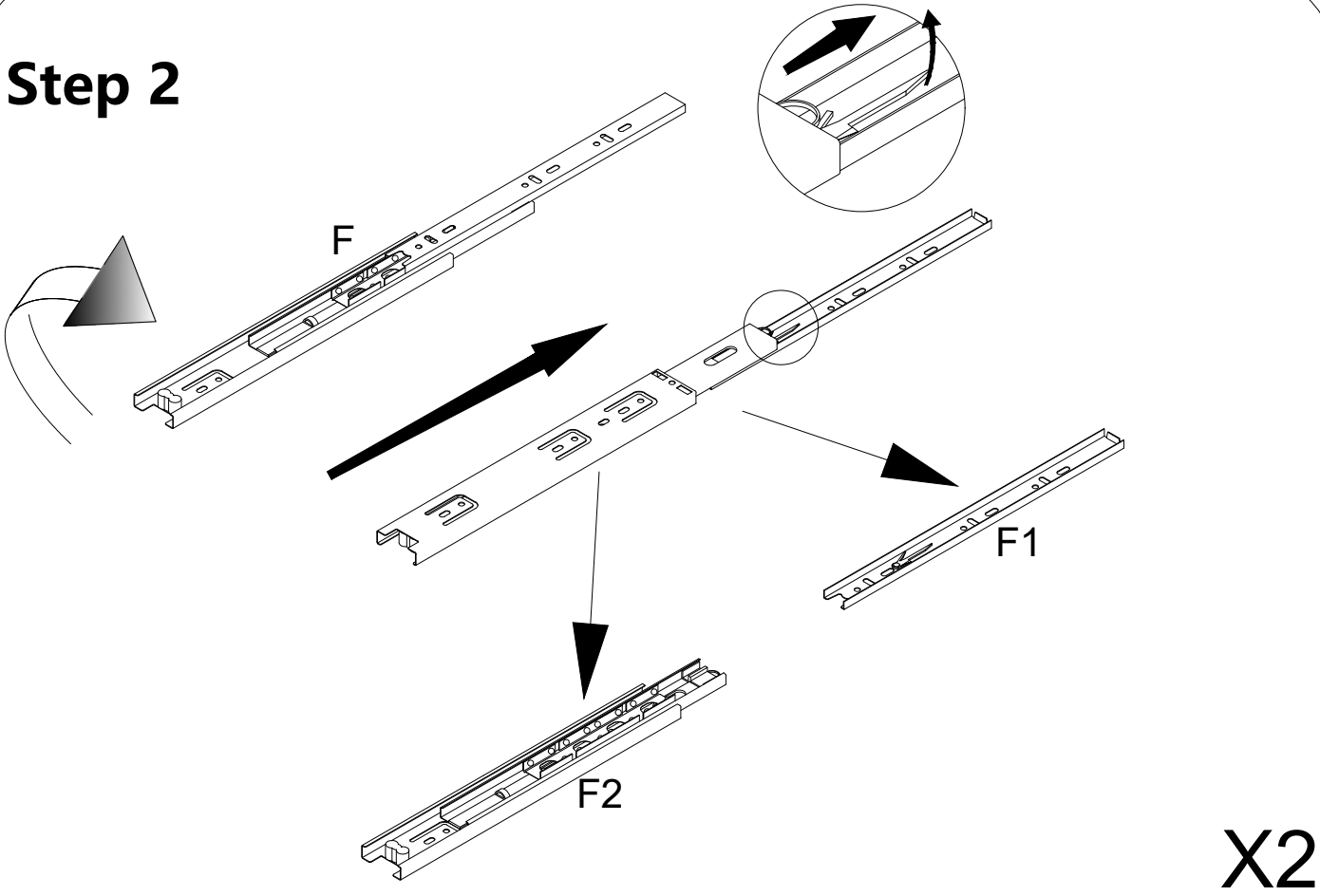

Step 3

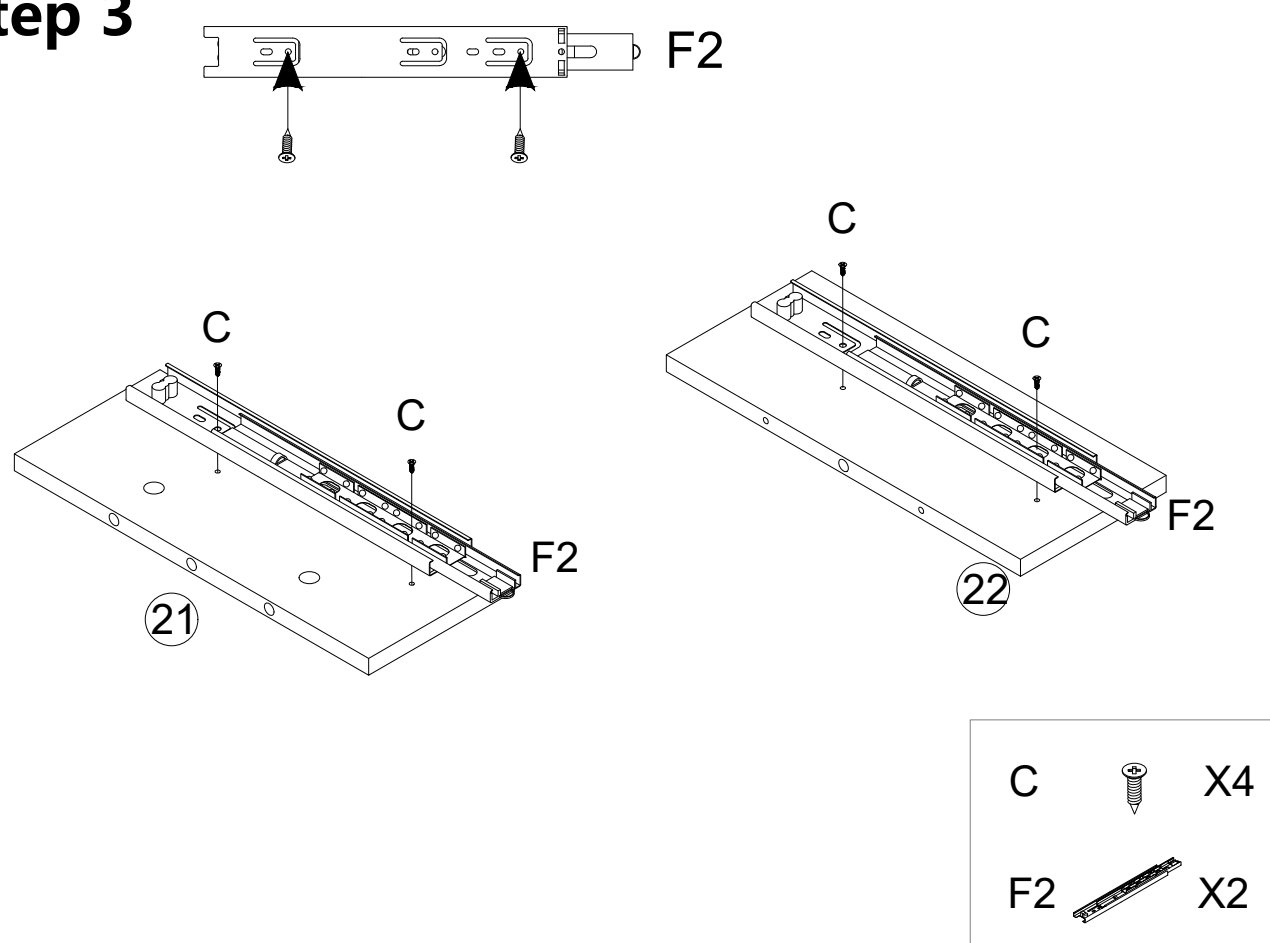

Assembly Instructions

Step 4

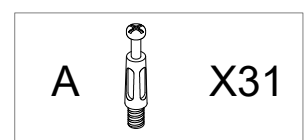
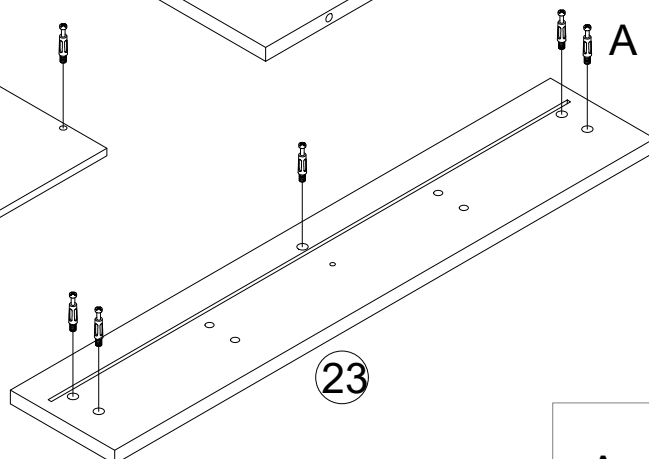
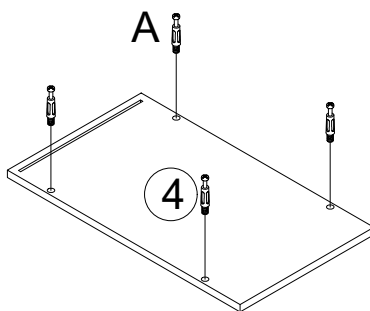
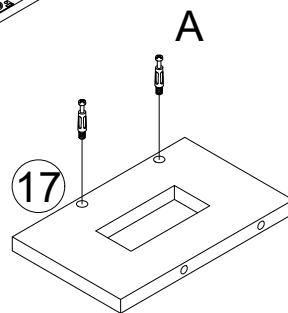
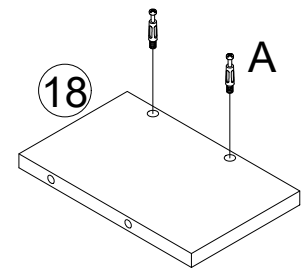
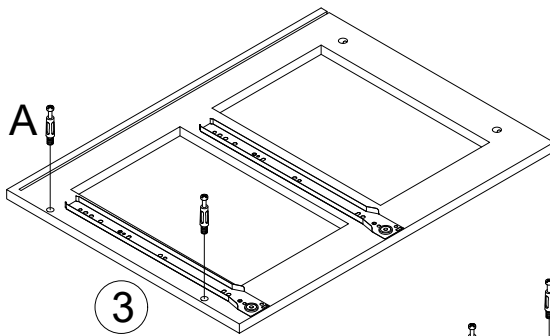
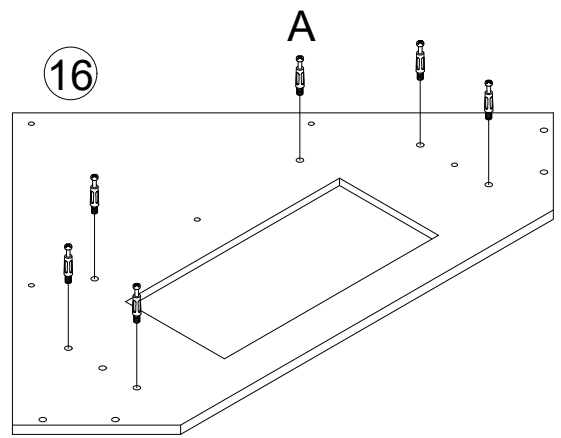
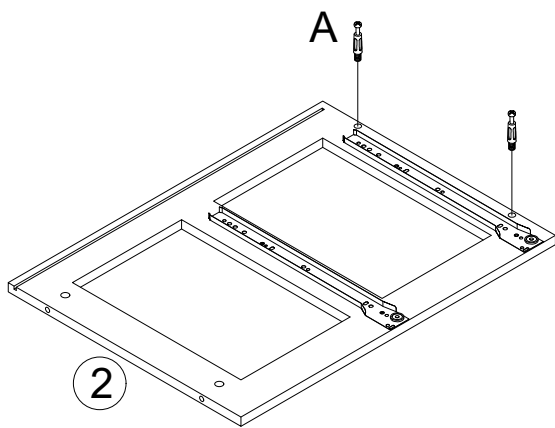
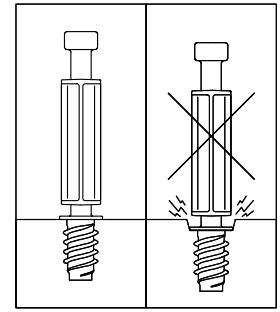
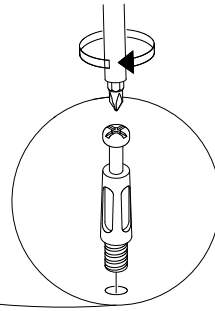
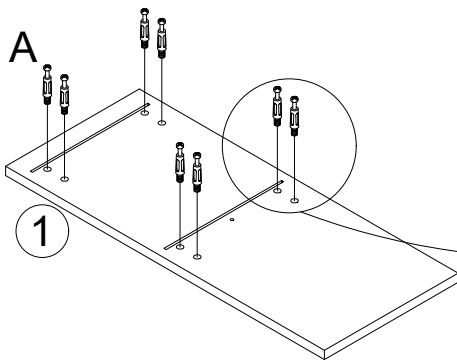

Assembly Instructions

Step 5

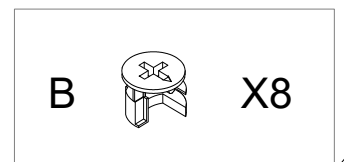
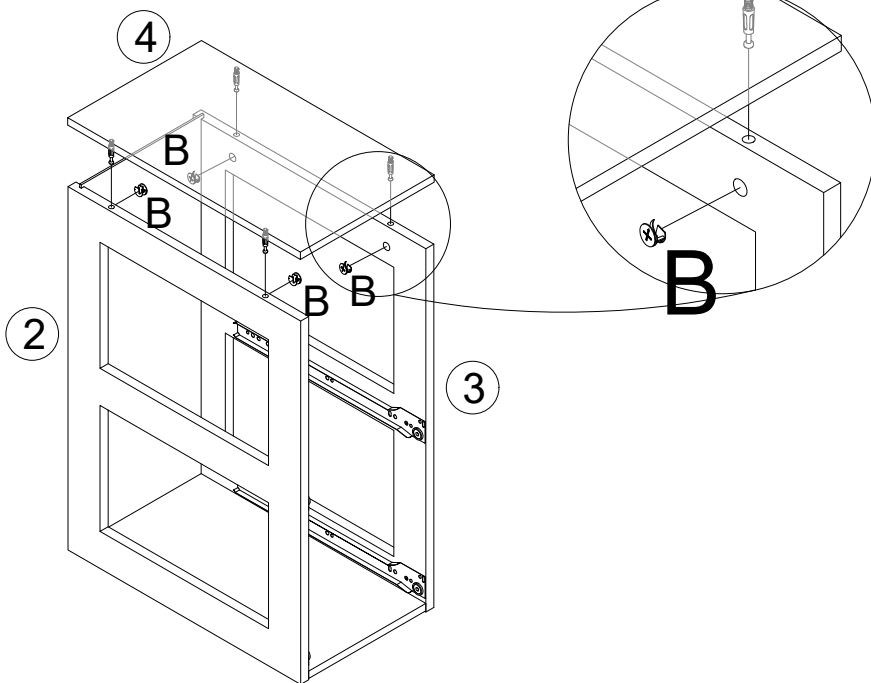
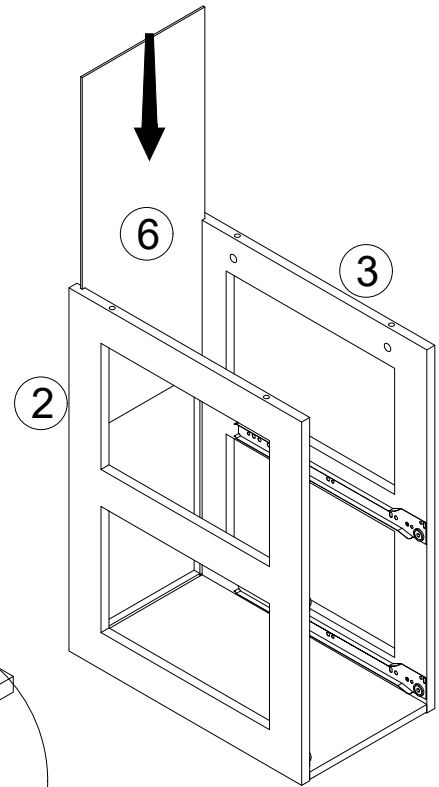
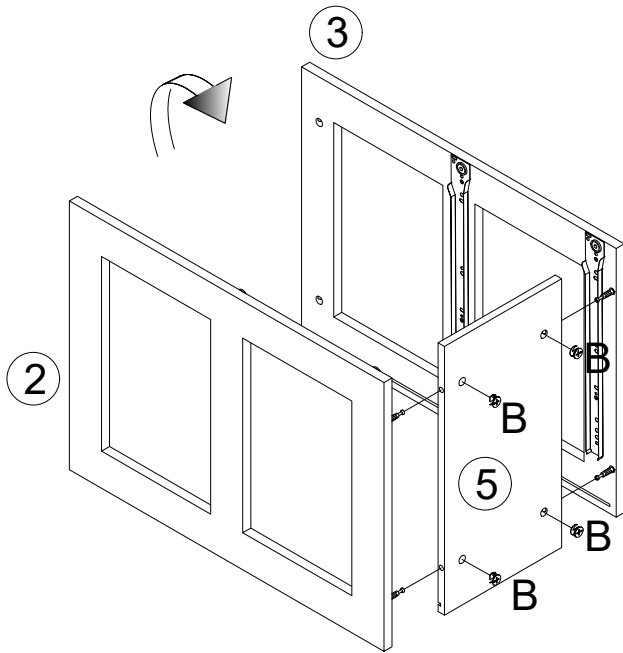
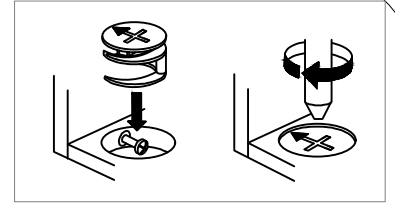



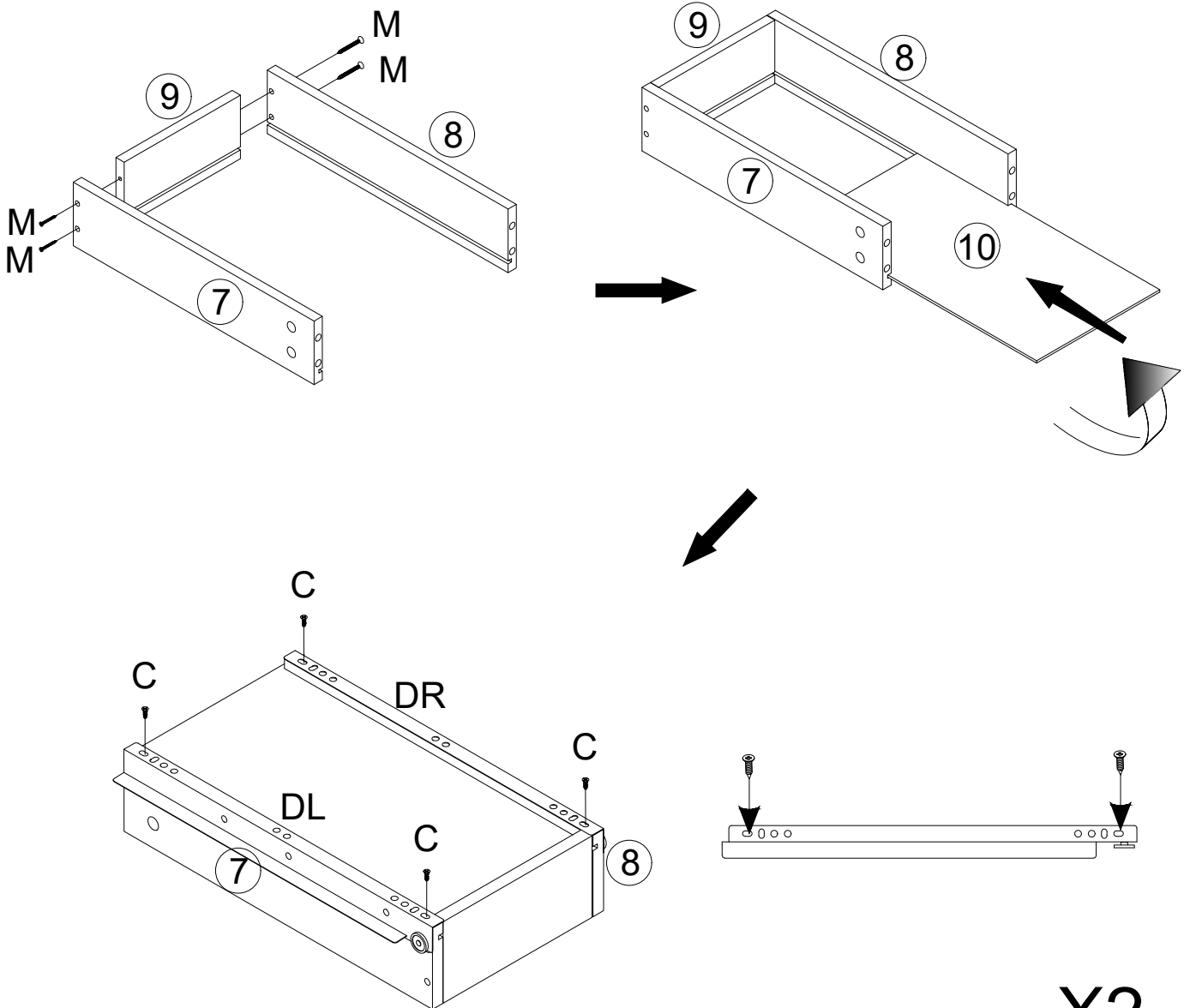

Assembly Instructions

Step 6



X2

C		X8
DL		X2
DR		X2
M		X8

Assembly Instructions

Step 7

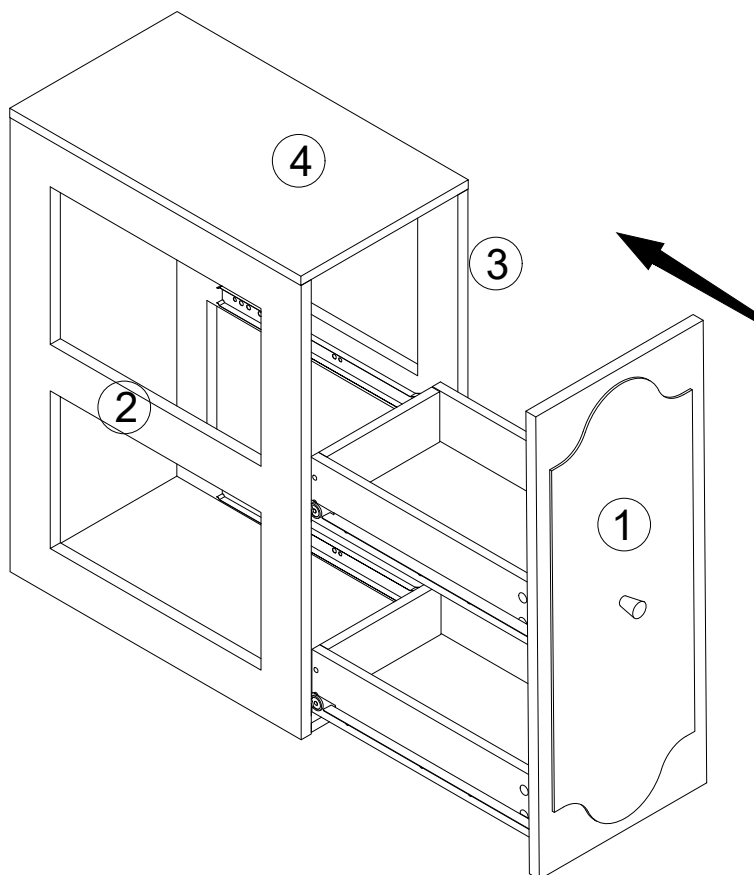
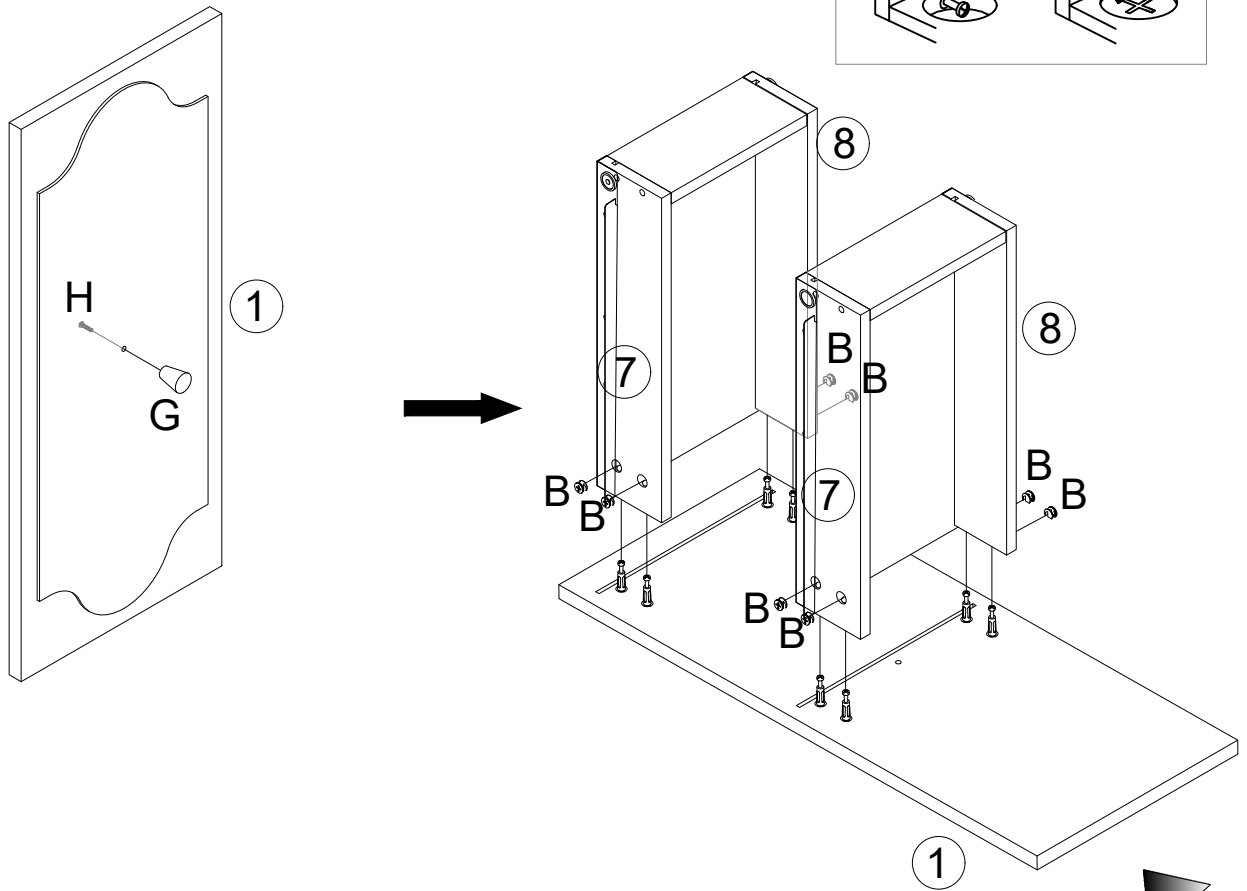
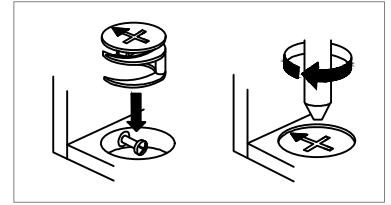



B		X8
G		X1
H		X1

Assembly Instructions

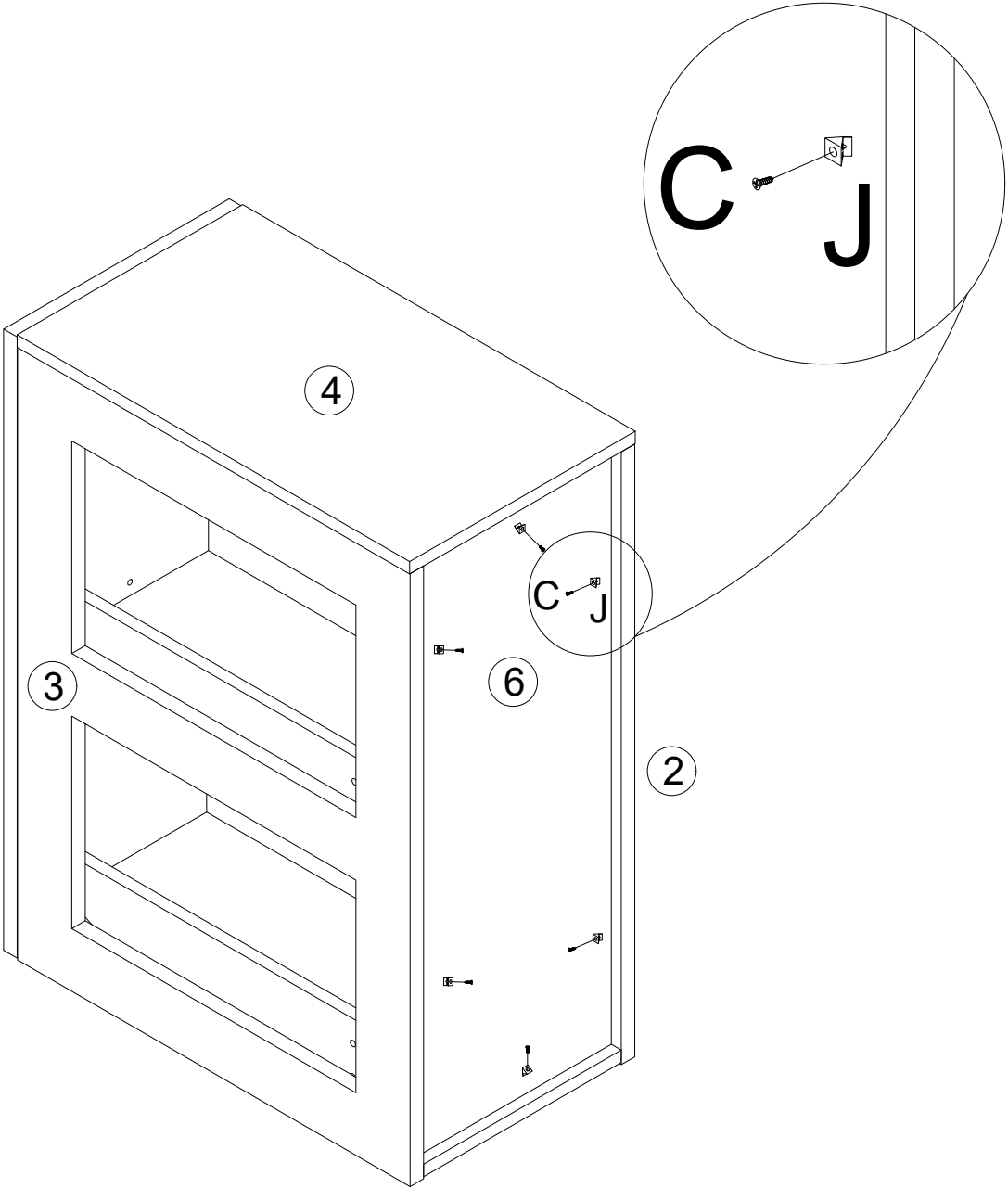
Step 8





C		X6
J		X6

Assembly Instructions

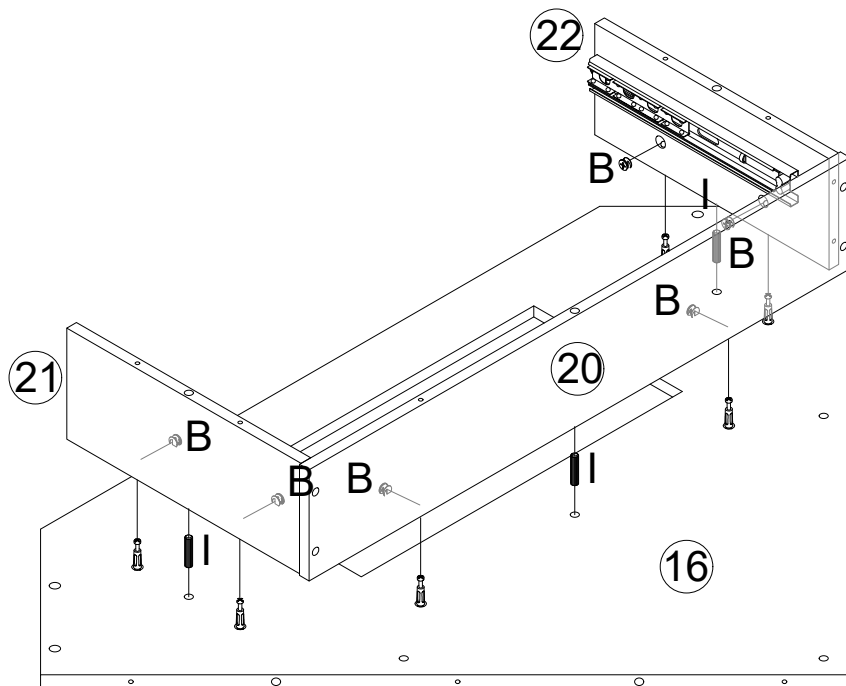
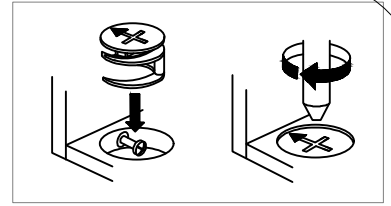
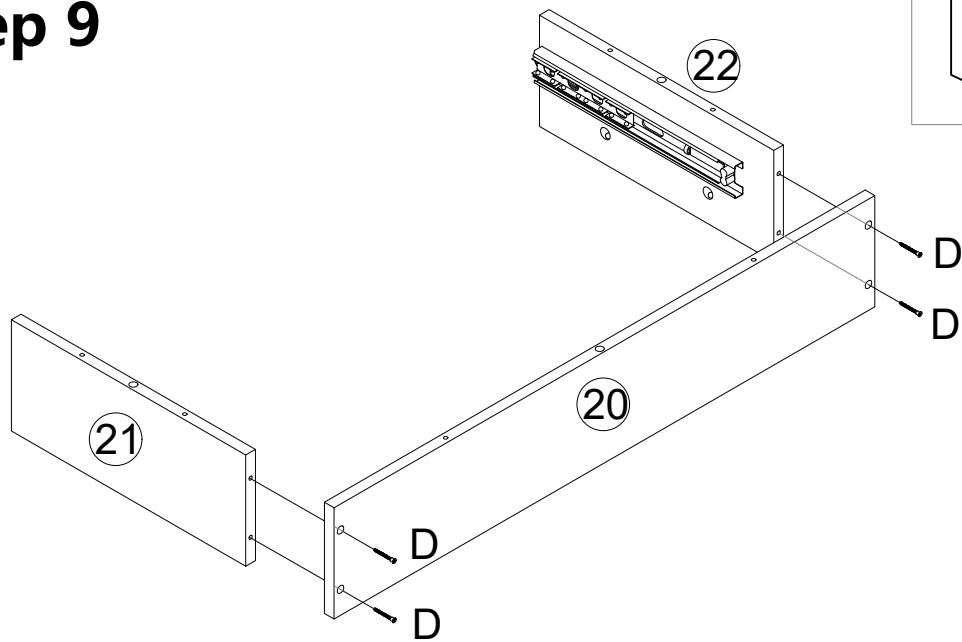
Step 9

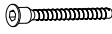



B		X6
D		X4
I		X3

Assembly Instructions

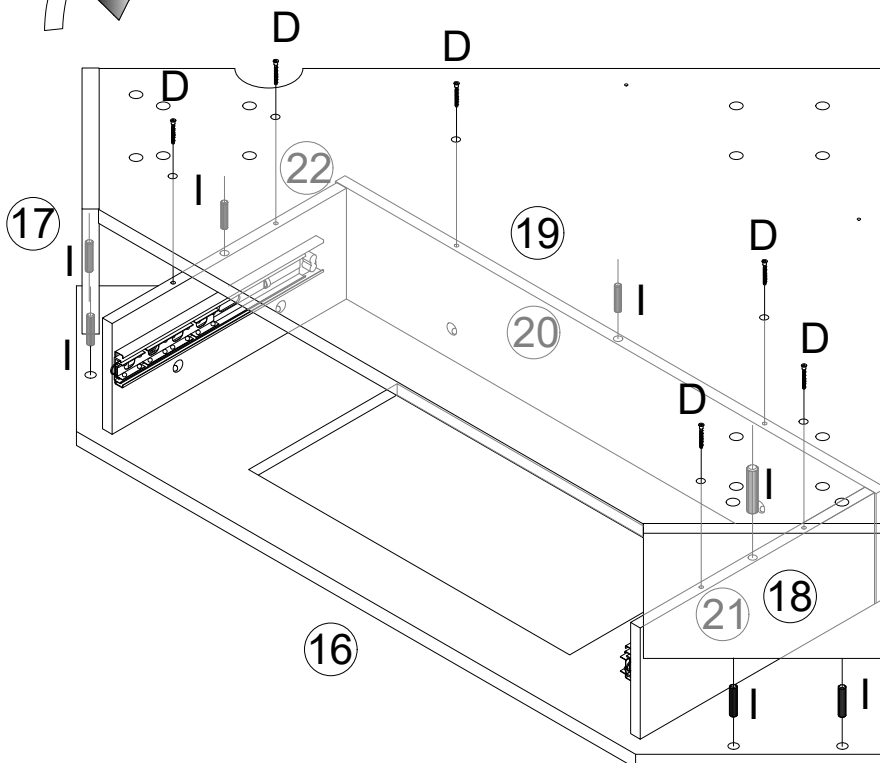
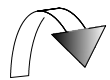
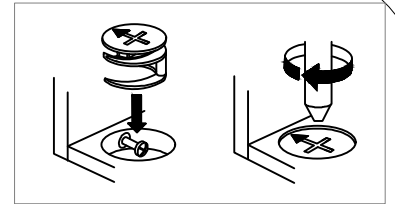
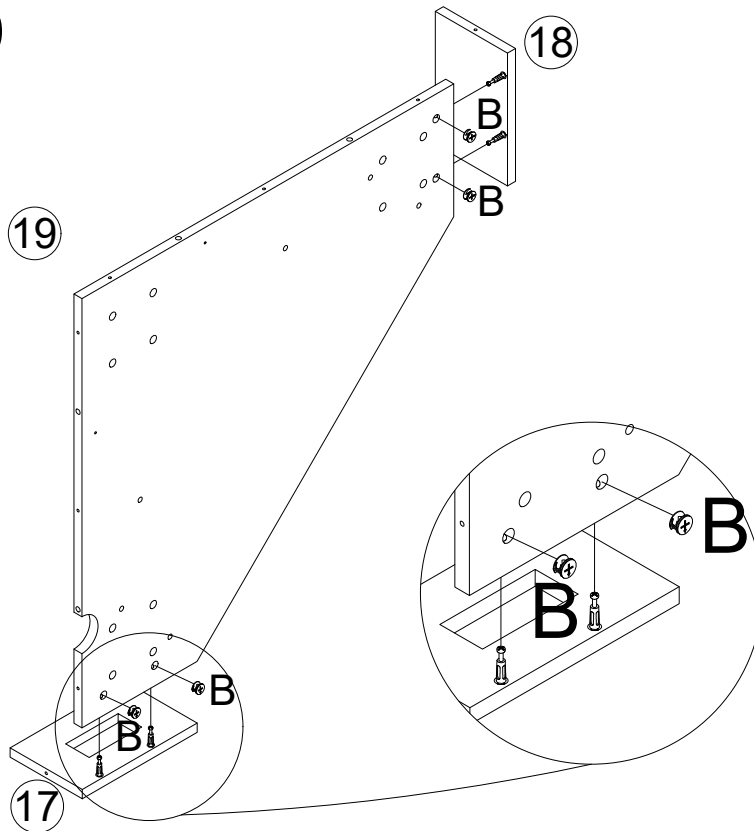
Step 10





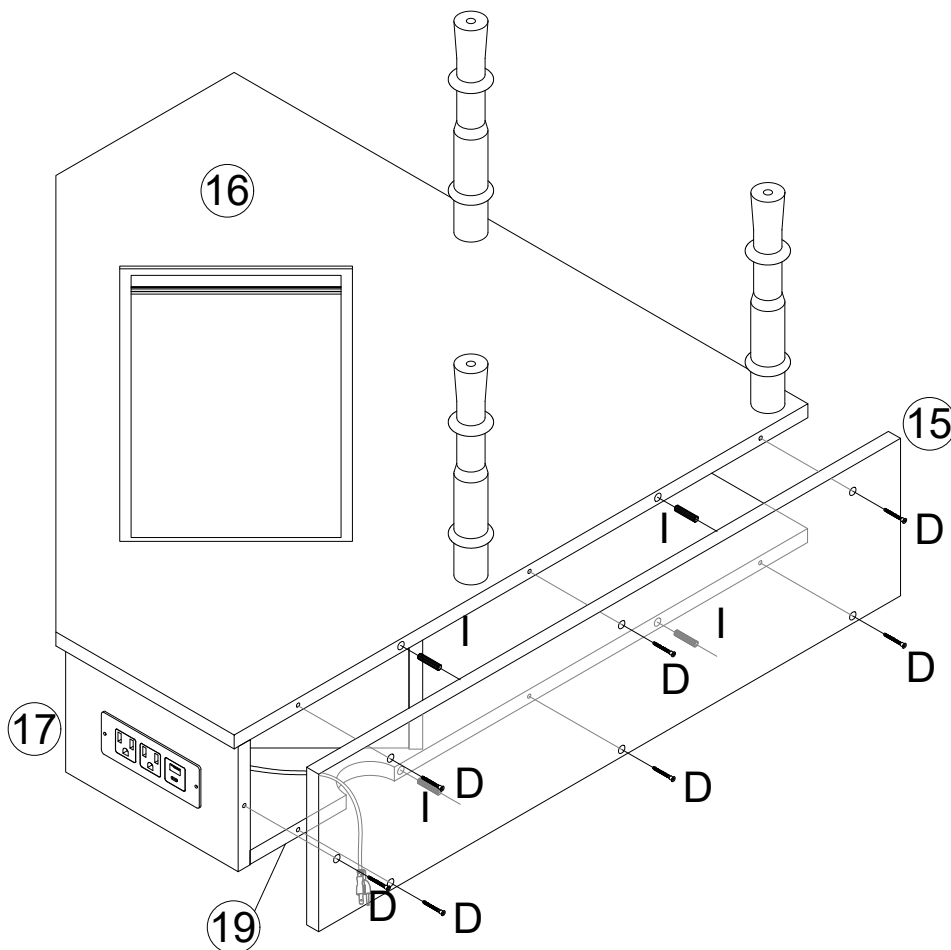
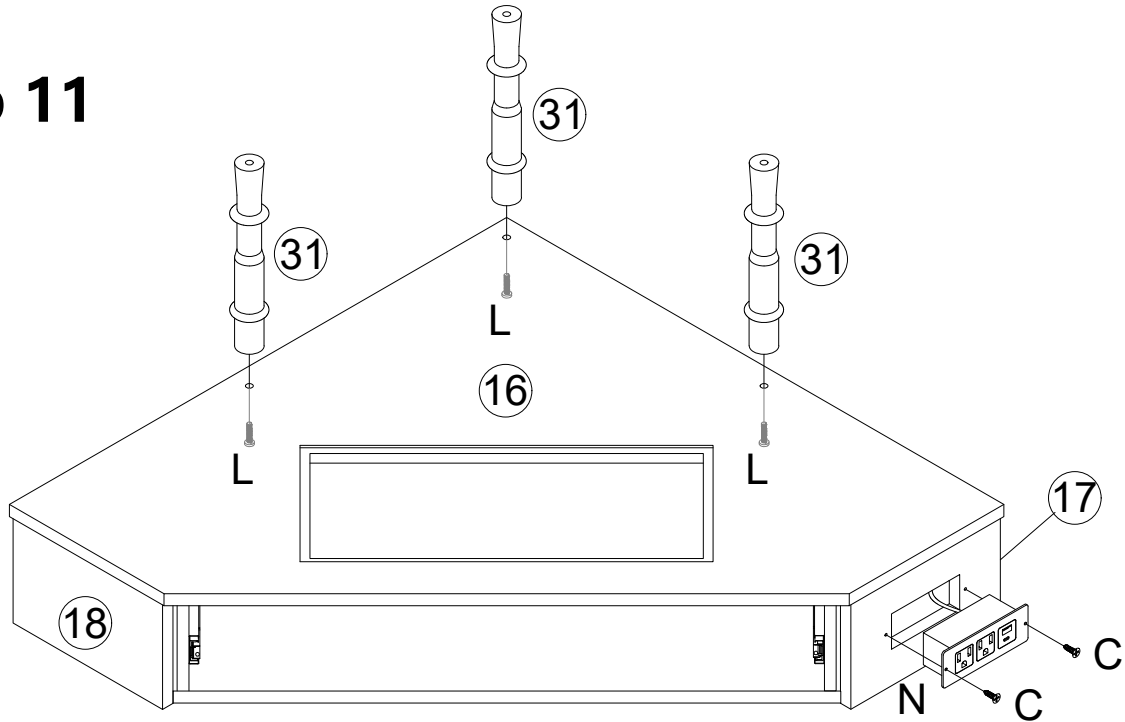

B		X4
D		X6
I		X7

Assembly Instructions

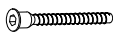
Step 11



C		X2
D		X7
I		X4
N		X1
L		X3

Assembly Instructions

Step 12

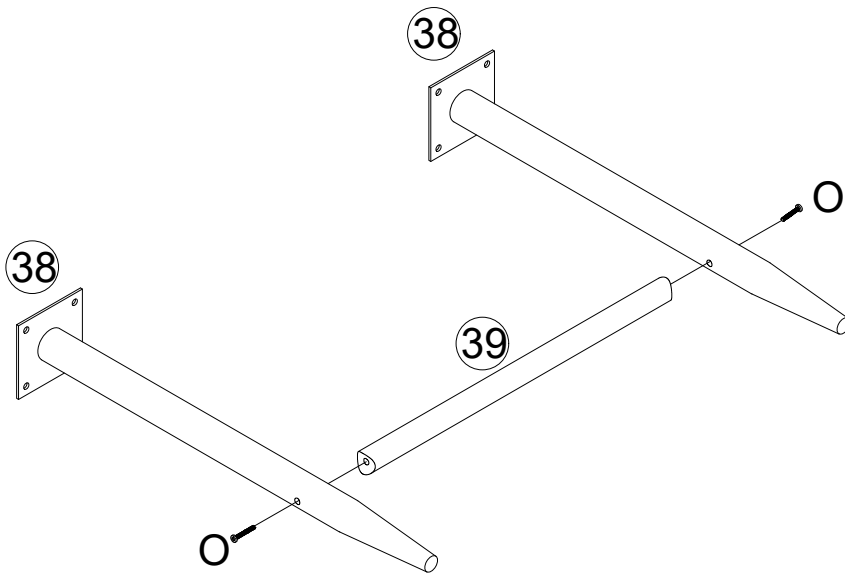
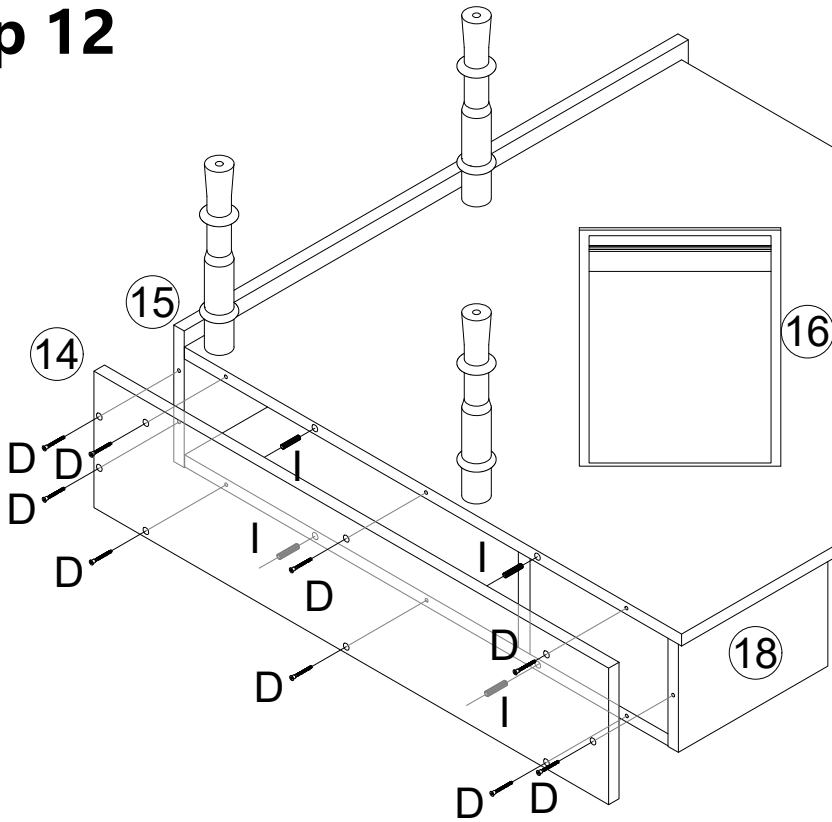

D  X9

I  X4

O  X2

Assembly Instructions

Step 13

Method 1

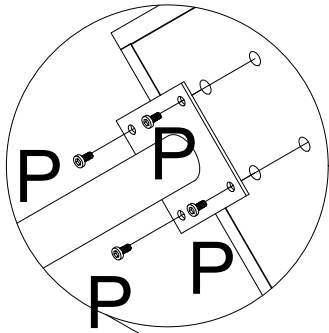

38

38

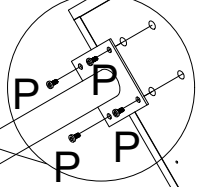

19

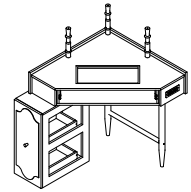
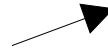
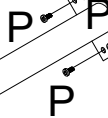

Method 2

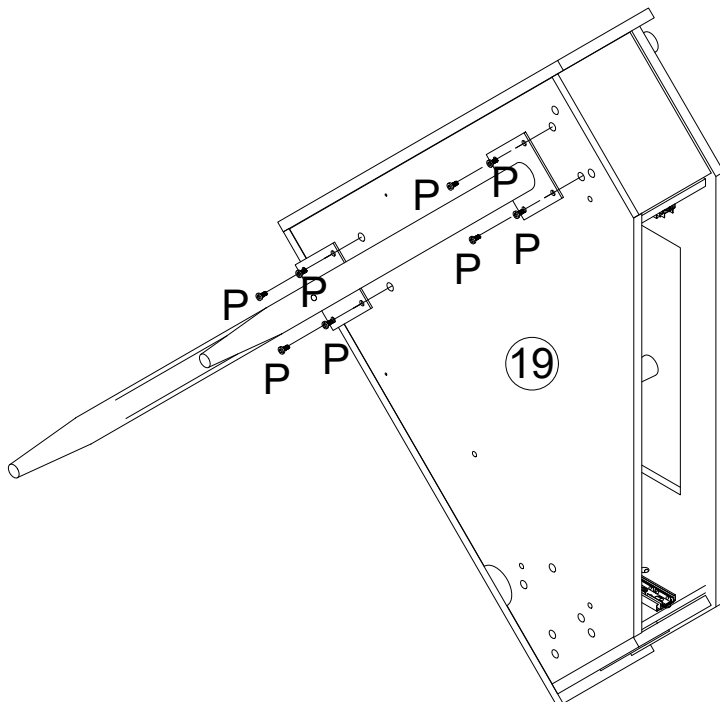

19

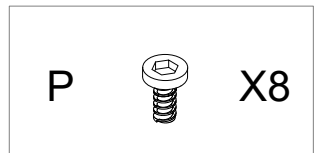
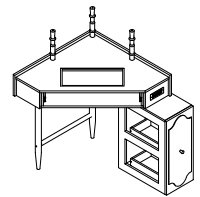
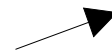

Assembly Instructions

Step 14

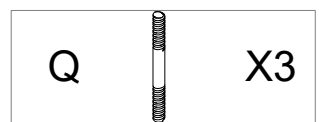
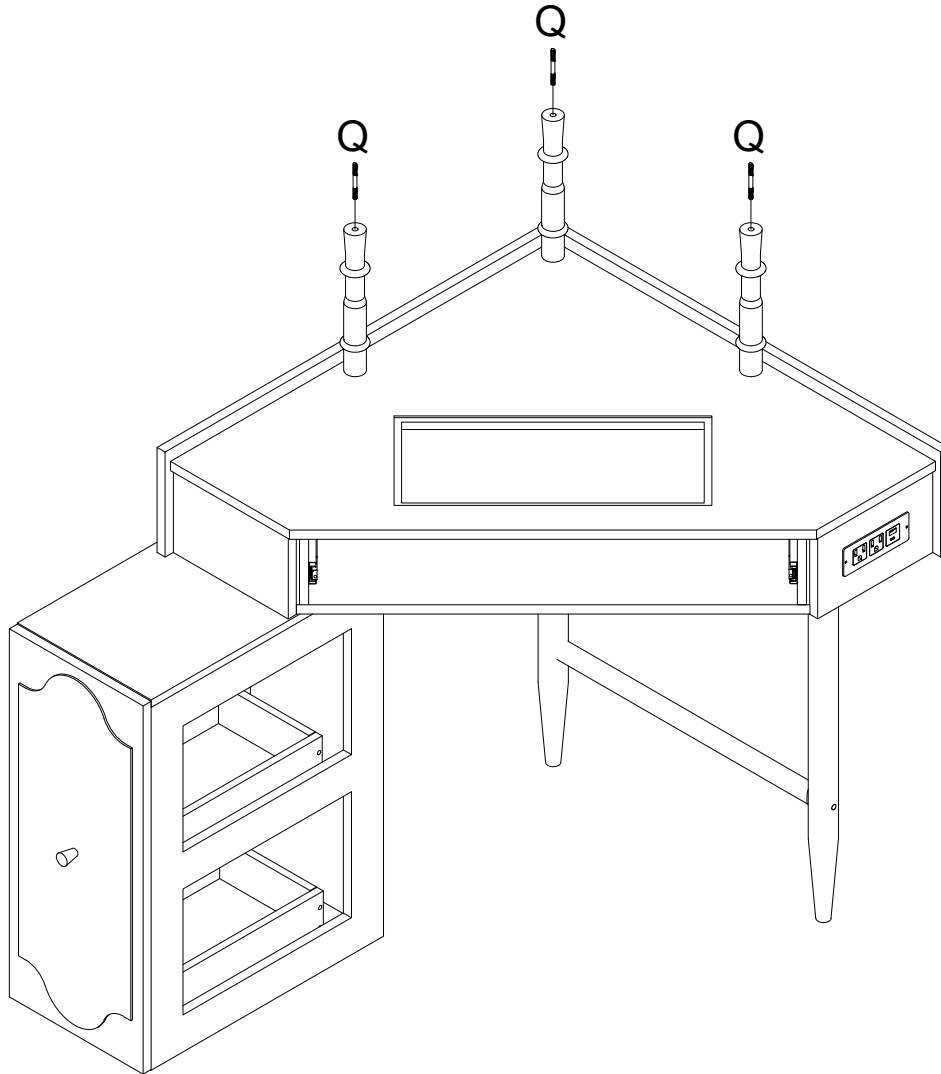

Assembly Instructions

Step 15

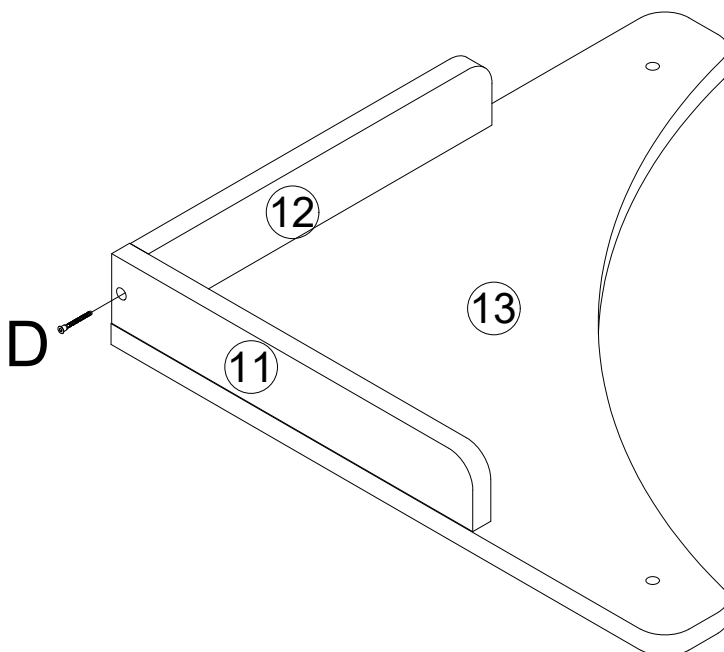
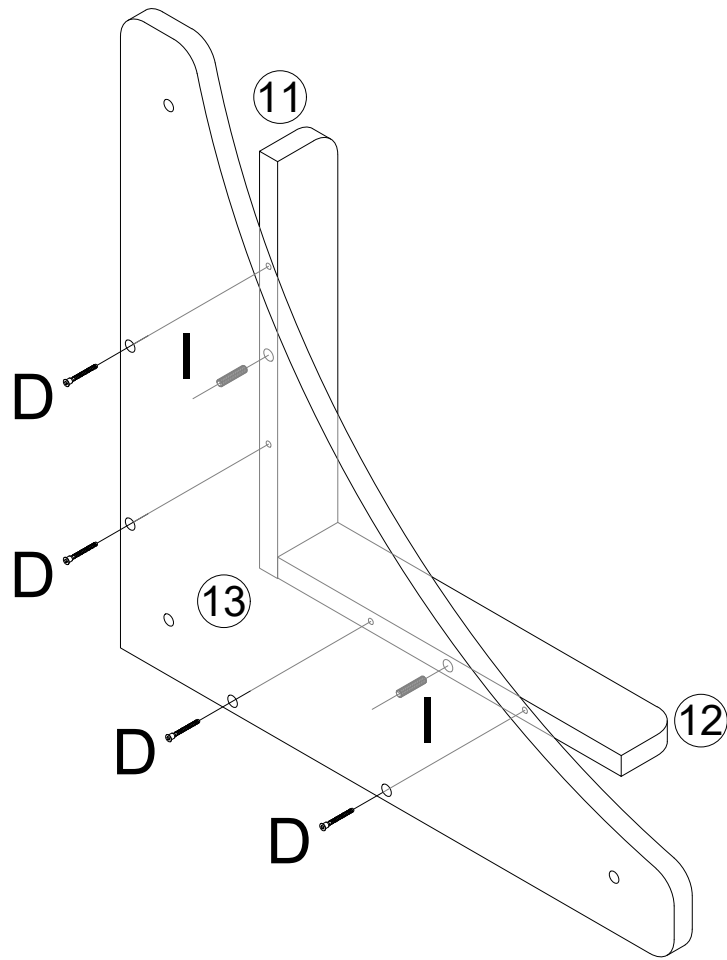

D  X5

I  X2

Assembly Instructions

Step 16

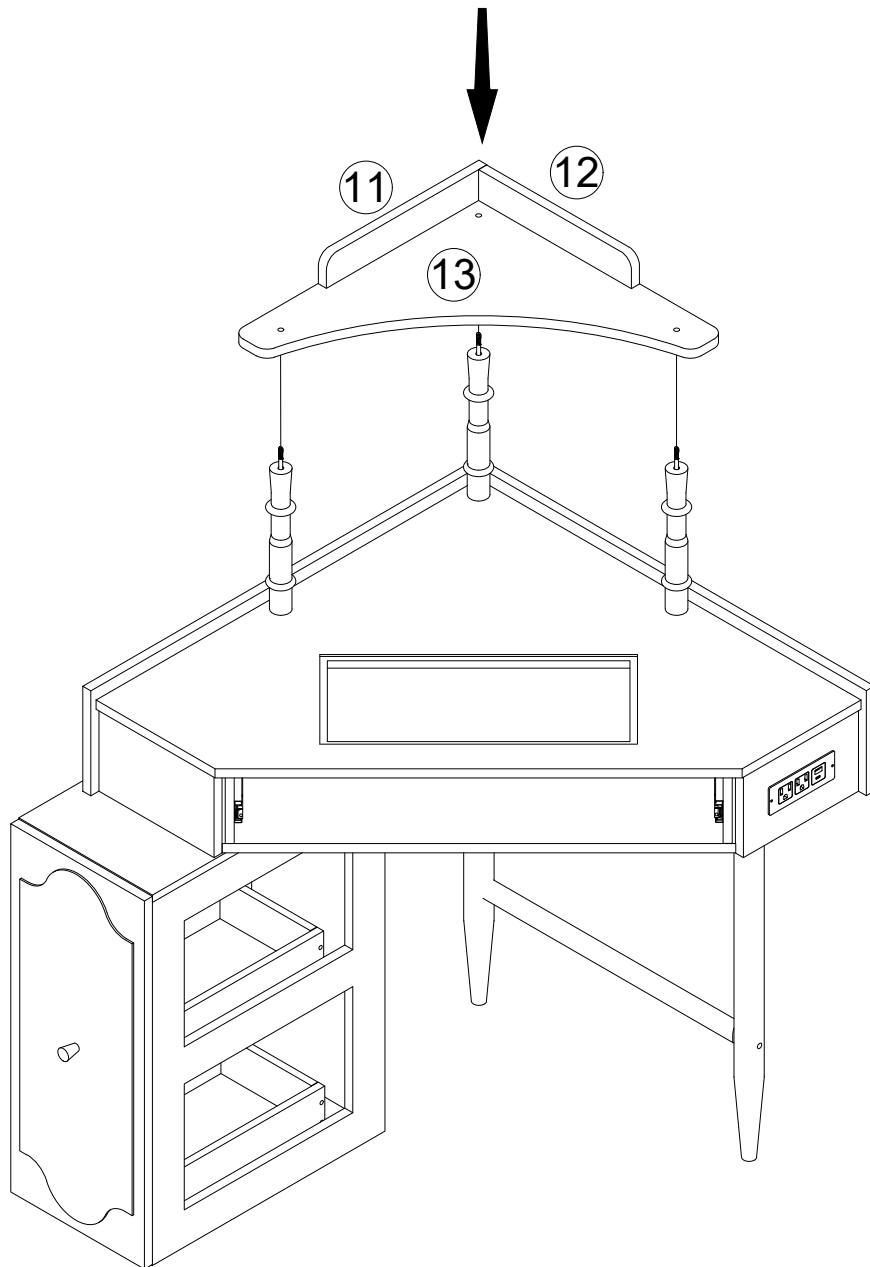

Assembly Instructions

Step 17

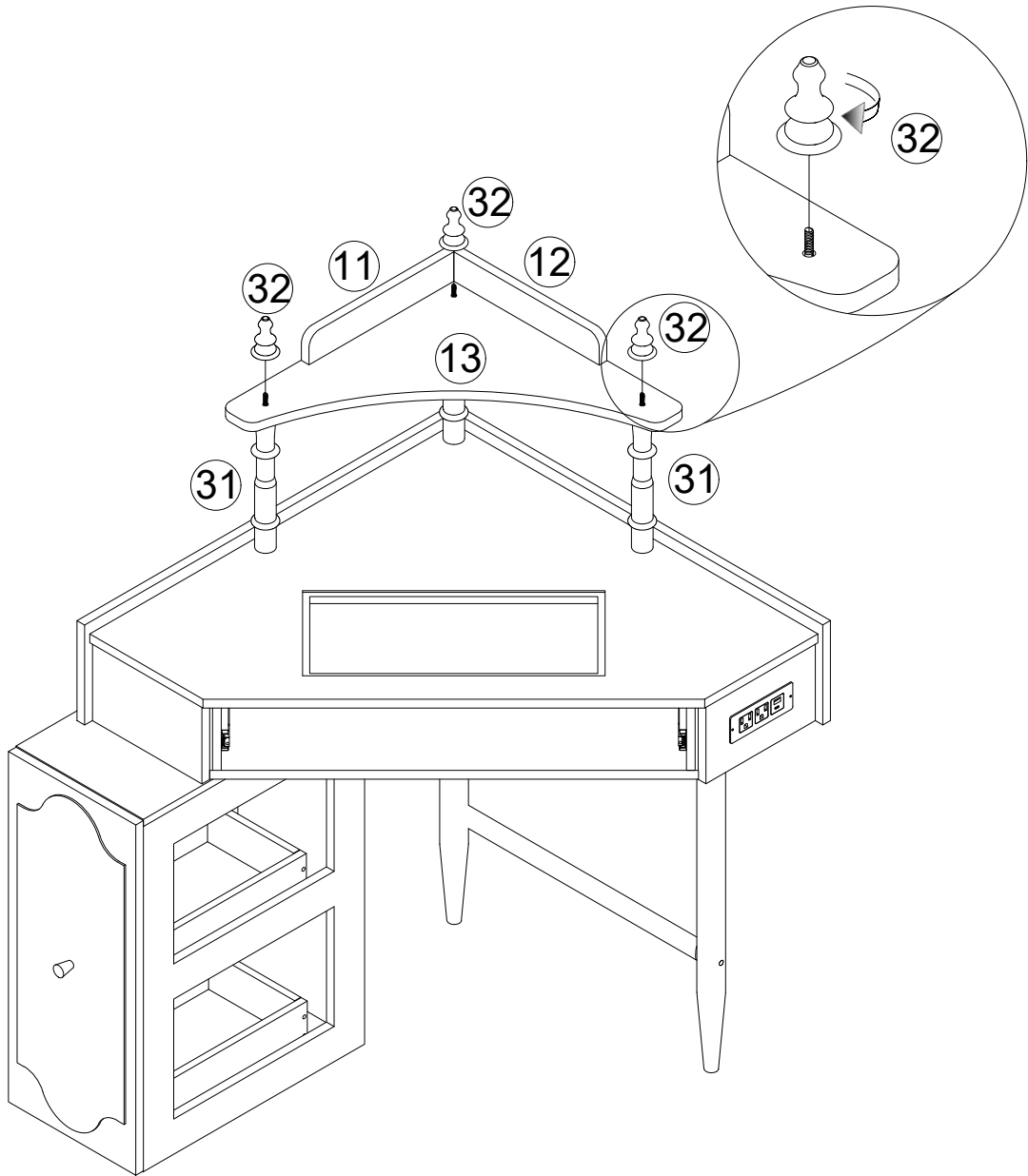

Assembly Instructions

Step 18

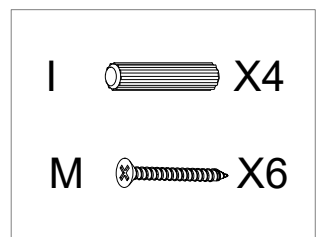
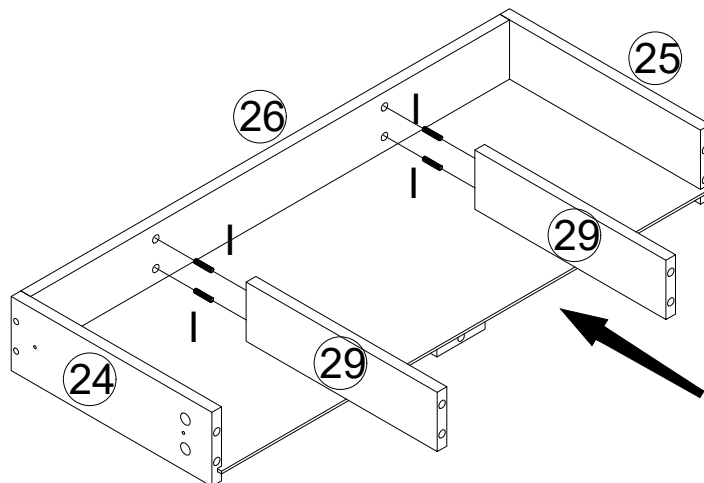
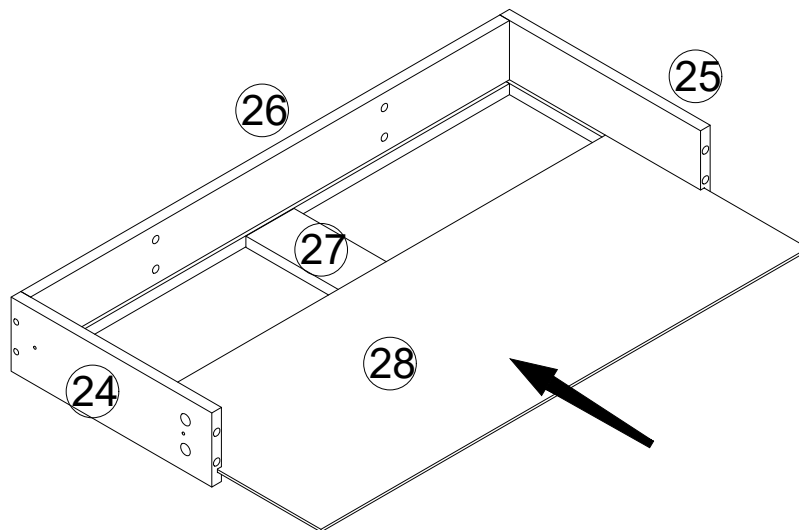
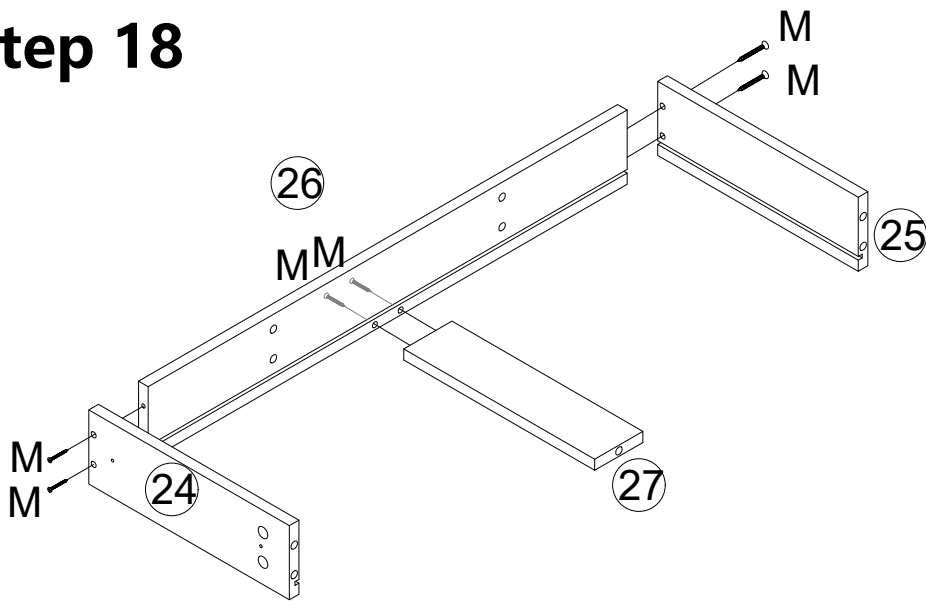

Assembly Instructions

Step 19

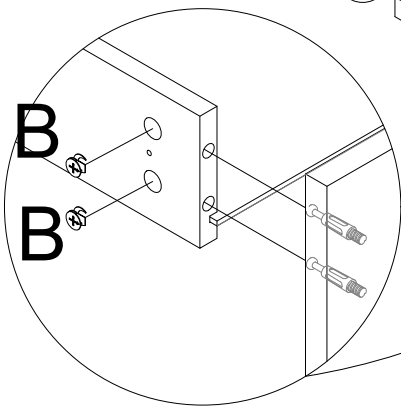
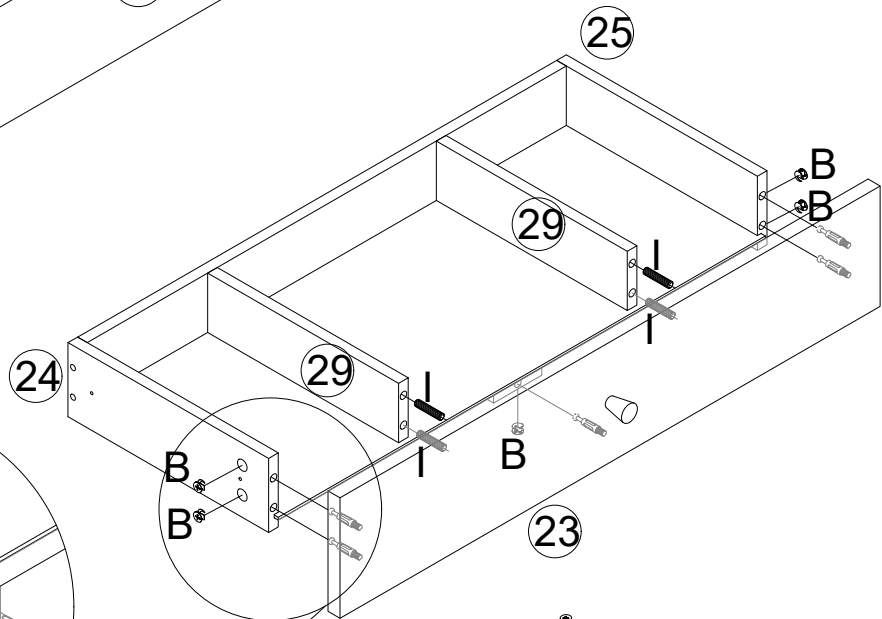
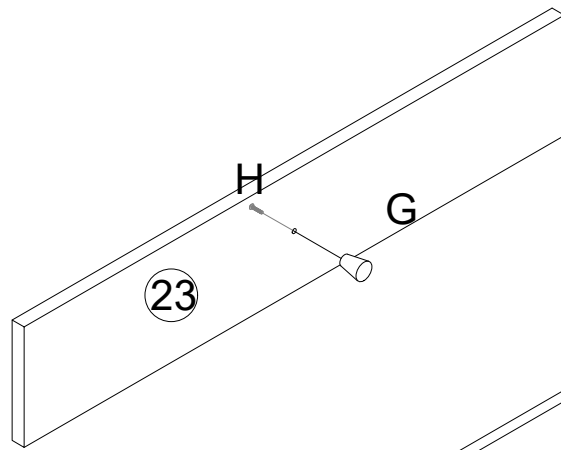
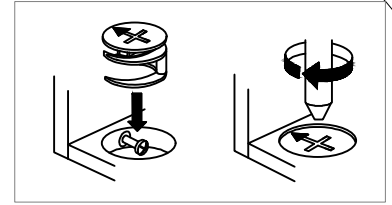

F1

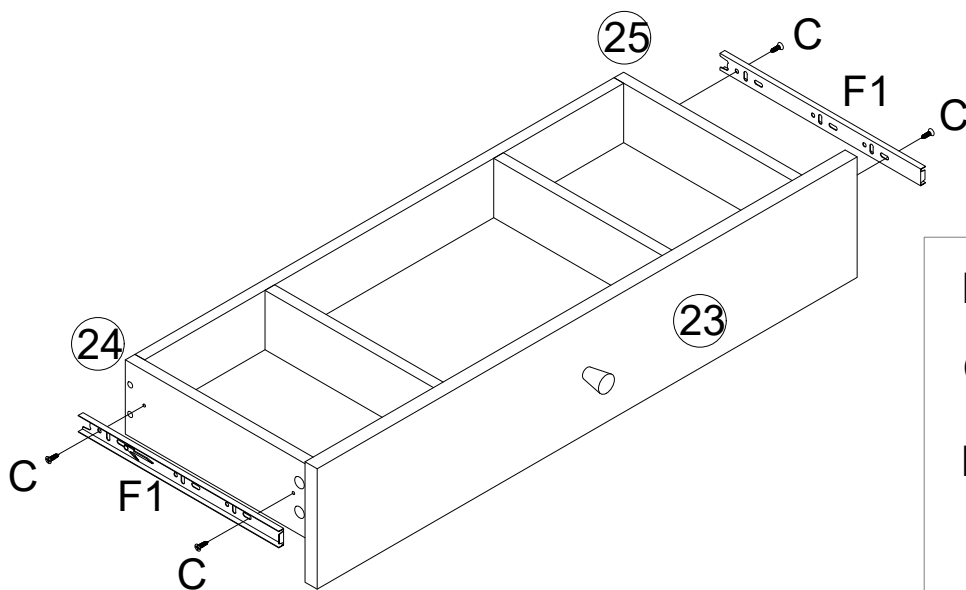

B		X5
C		X4
F1		X2
I		X4
G		X1
H		X1

Assembly Instructions

Step 20

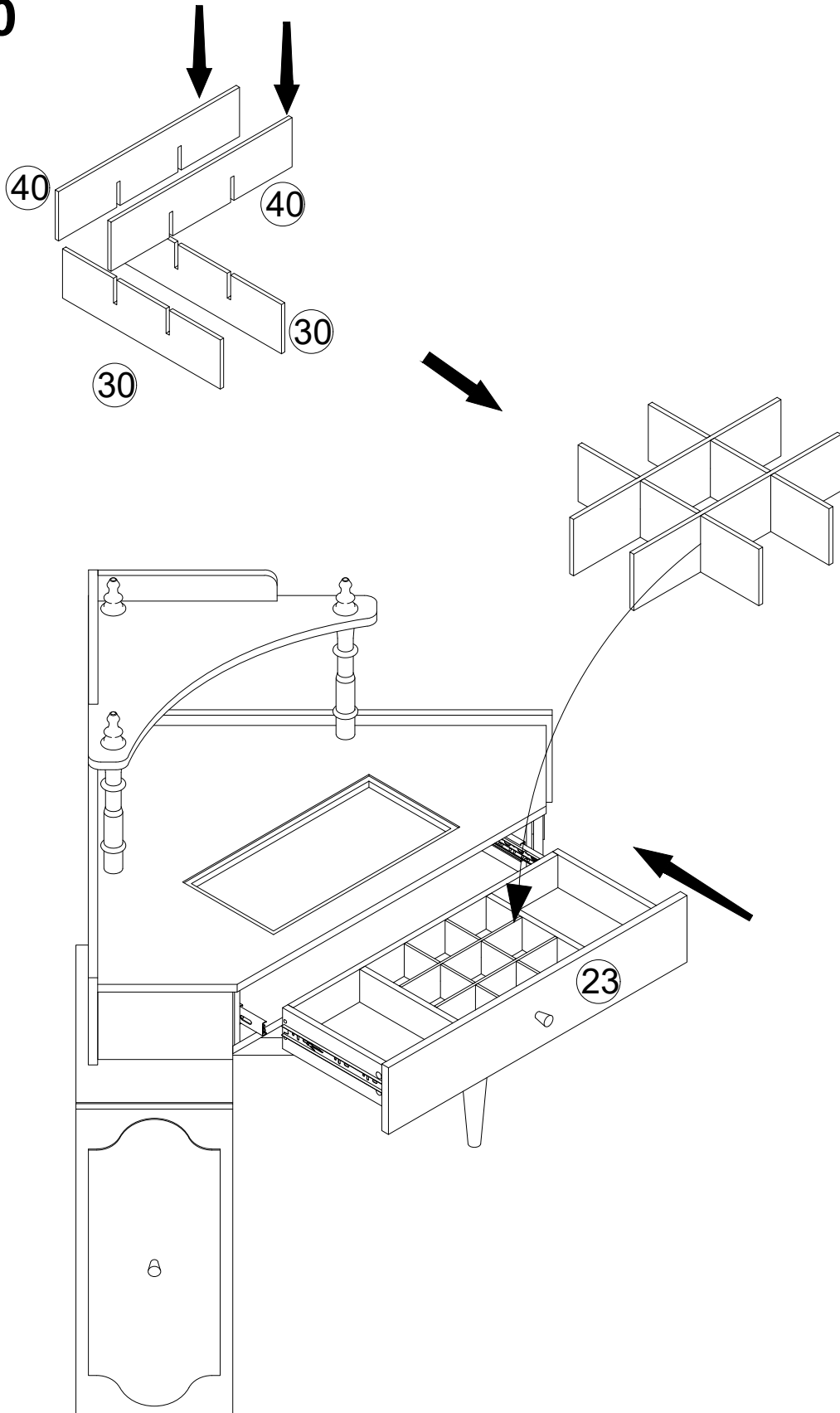

Assembly Instructions

Step 21

WALL

WALL

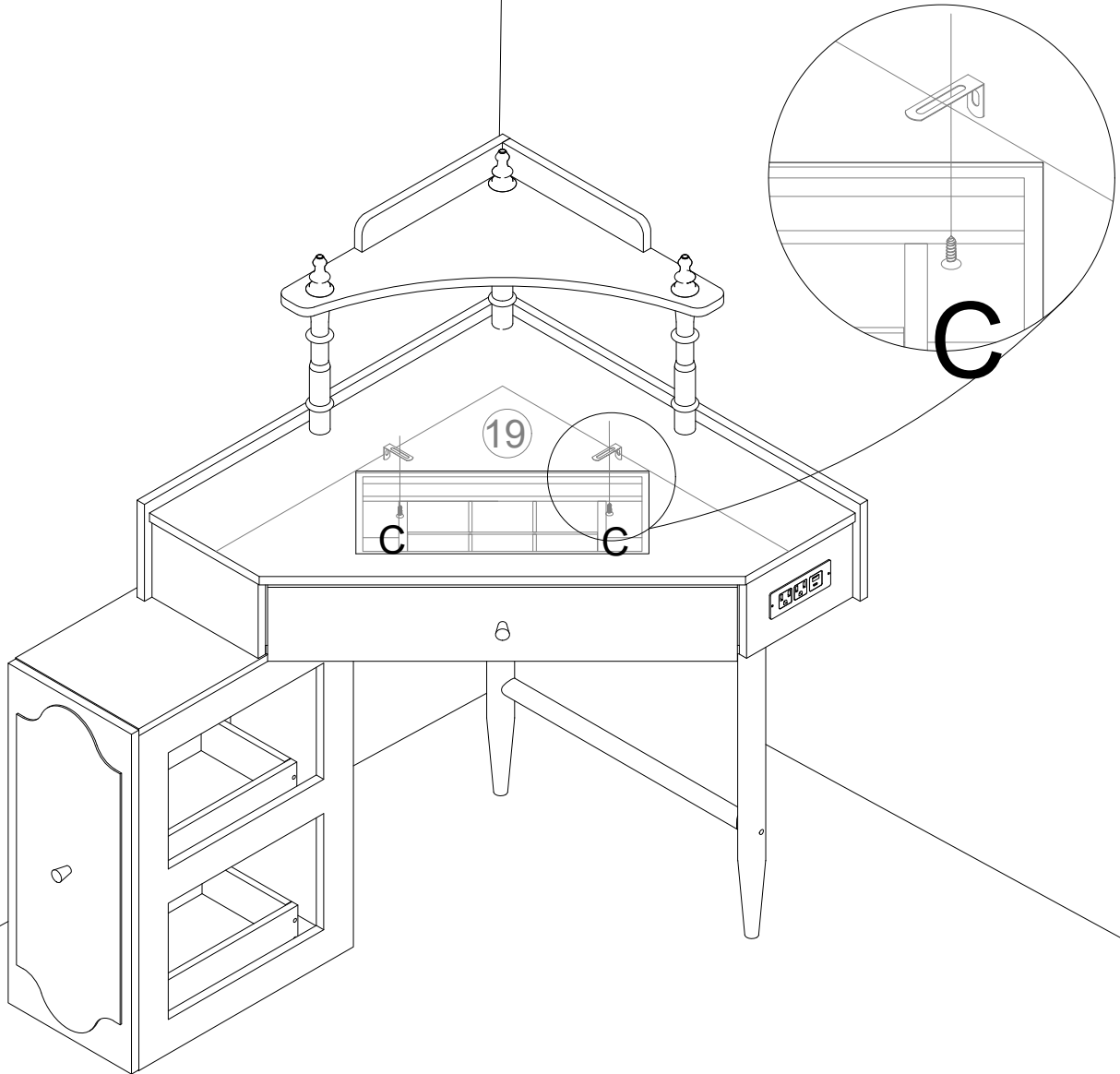

C  X2

K  X2

Assembly Instructions

Step 22

WALL

WALL

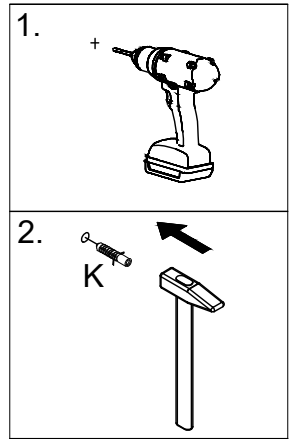
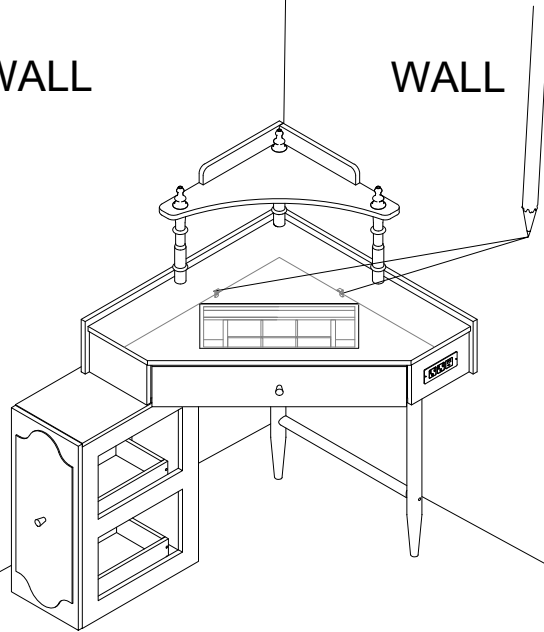

WALL

WALL



K



K

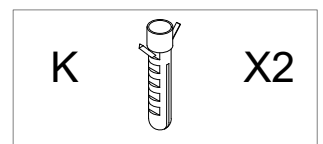
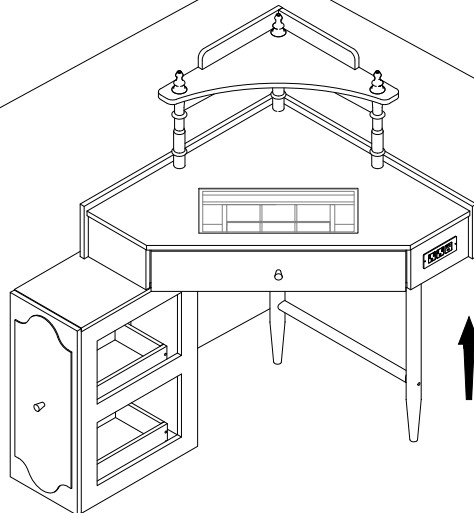

Assembly Instructions

Step 23

WALL

WALL

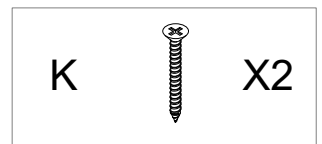
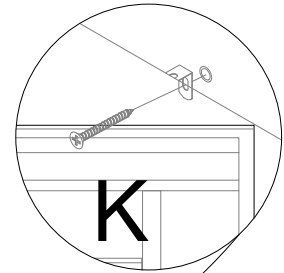
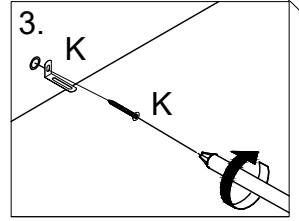
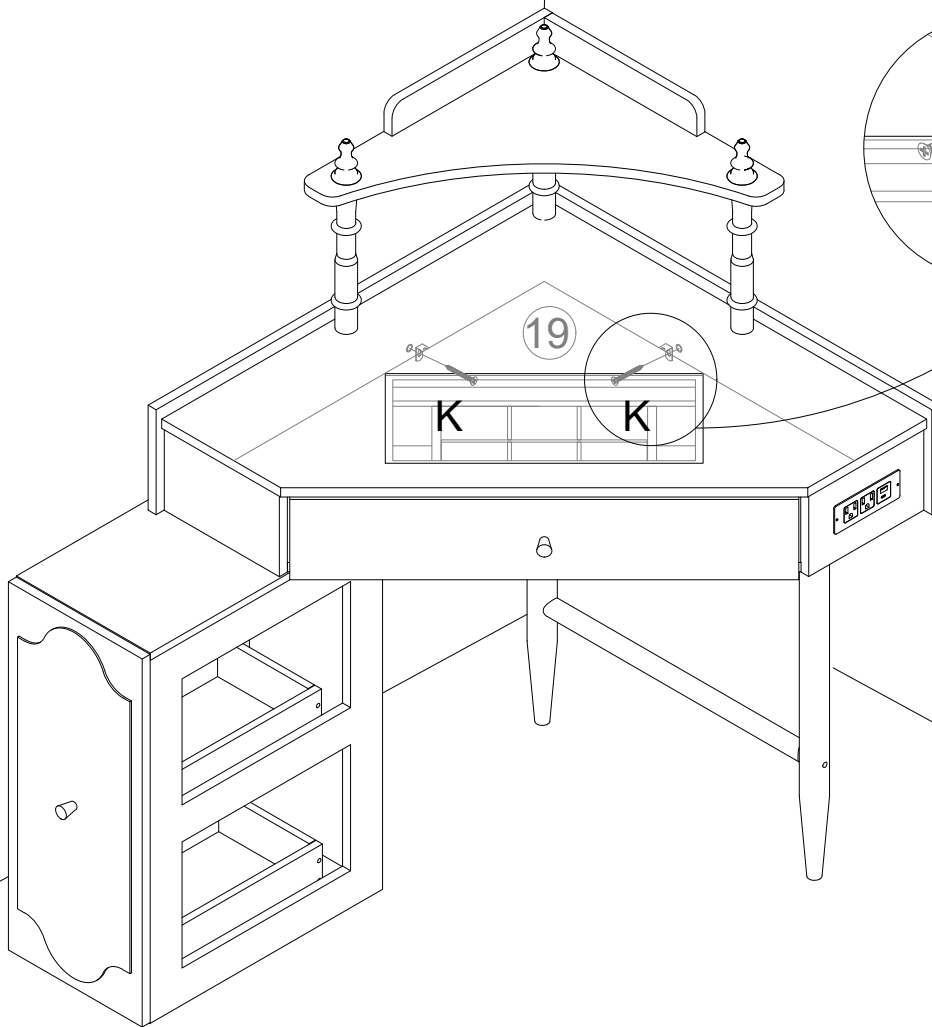

Assembly Instructions

Step 24

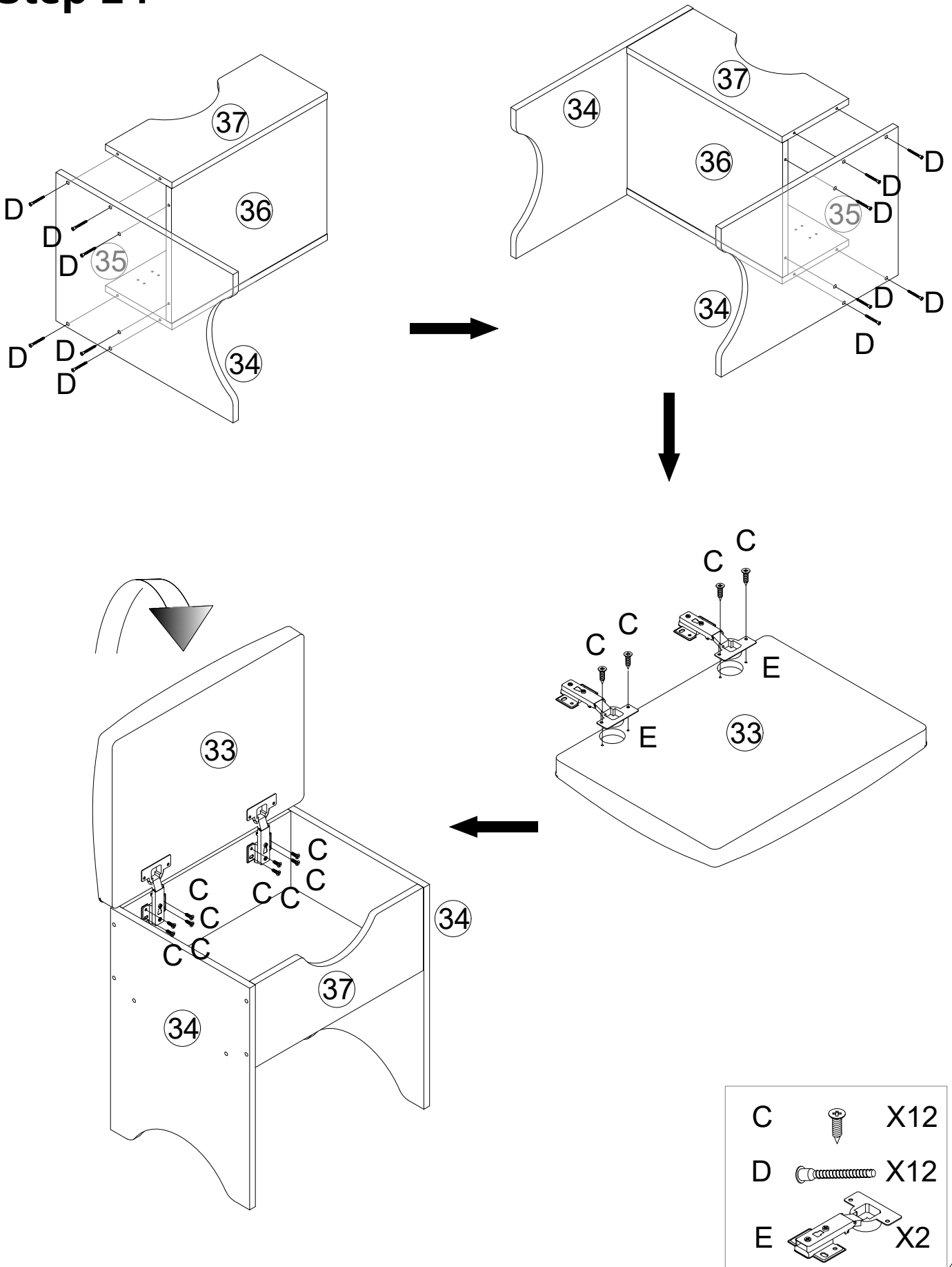

Assembly Instructions

Step 25

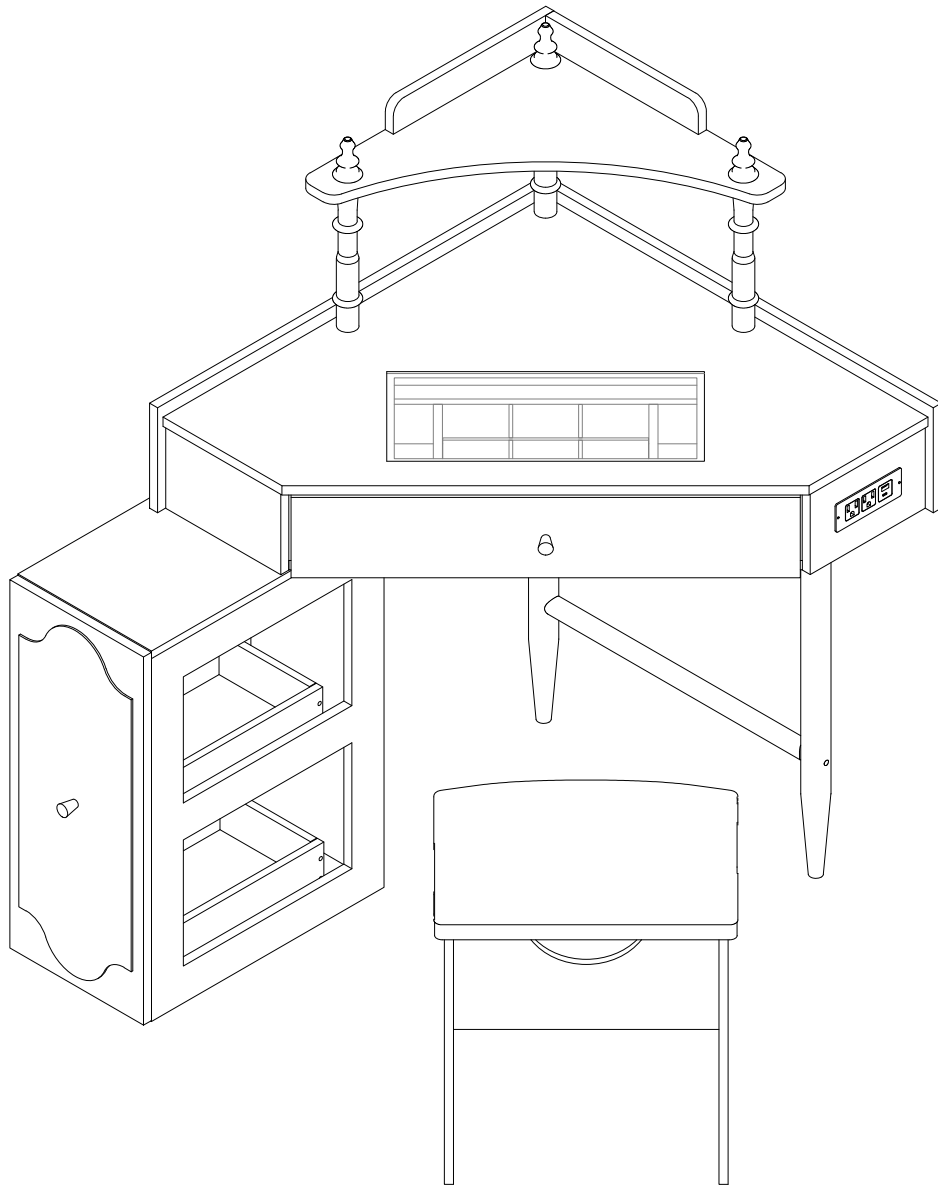

Product Name: Table

"This device complies with Part 15 of the FCC Rules. Operation is subject to the following two conditions: (1) this device may not cause harmful interference, and (2) this device must accept any interference received, including interference that may cause undesired operation."