

# ASSEMBLY INSTRUCTION

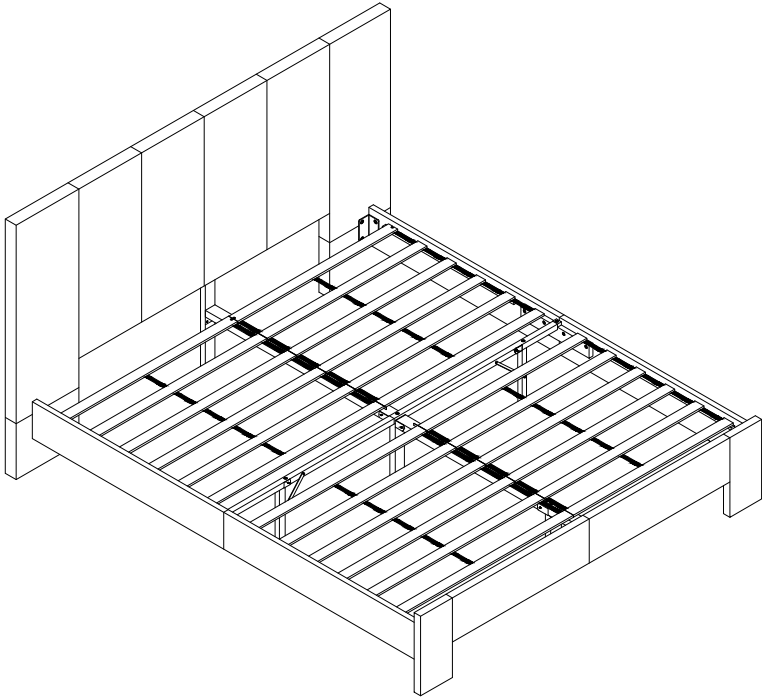

Please **TEAR OFF** this shrink film from side!  
**DO NOT USE CUTTER!**

ITEM NUMBER:BU006

## IMPORTANT NOTE

1. For the protection of your furniture, place all parts on a clean and smooth surface to prevent any damage.
2. Keep fittings out of children's reach and keep children well away from construction area.
3. When moving your assembled bed. it is best to lift the bed and never to drag it.
4. Do not use this product if parts are missing, damaged or worn.
5. This product should only be used on firm, level ground.
6. Please periodically check all fittings and re-tighten as necessary.
7. Do not use the bed unless all bolts and screws are firmly secured.
8. For further assistance, please provide a screenshot of your order and contact us via email at [support@velocavabed.com](mailto:support@velocavabed.com)

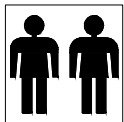

Minimum two  
person assembly

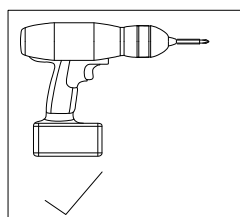

**PART LIST**

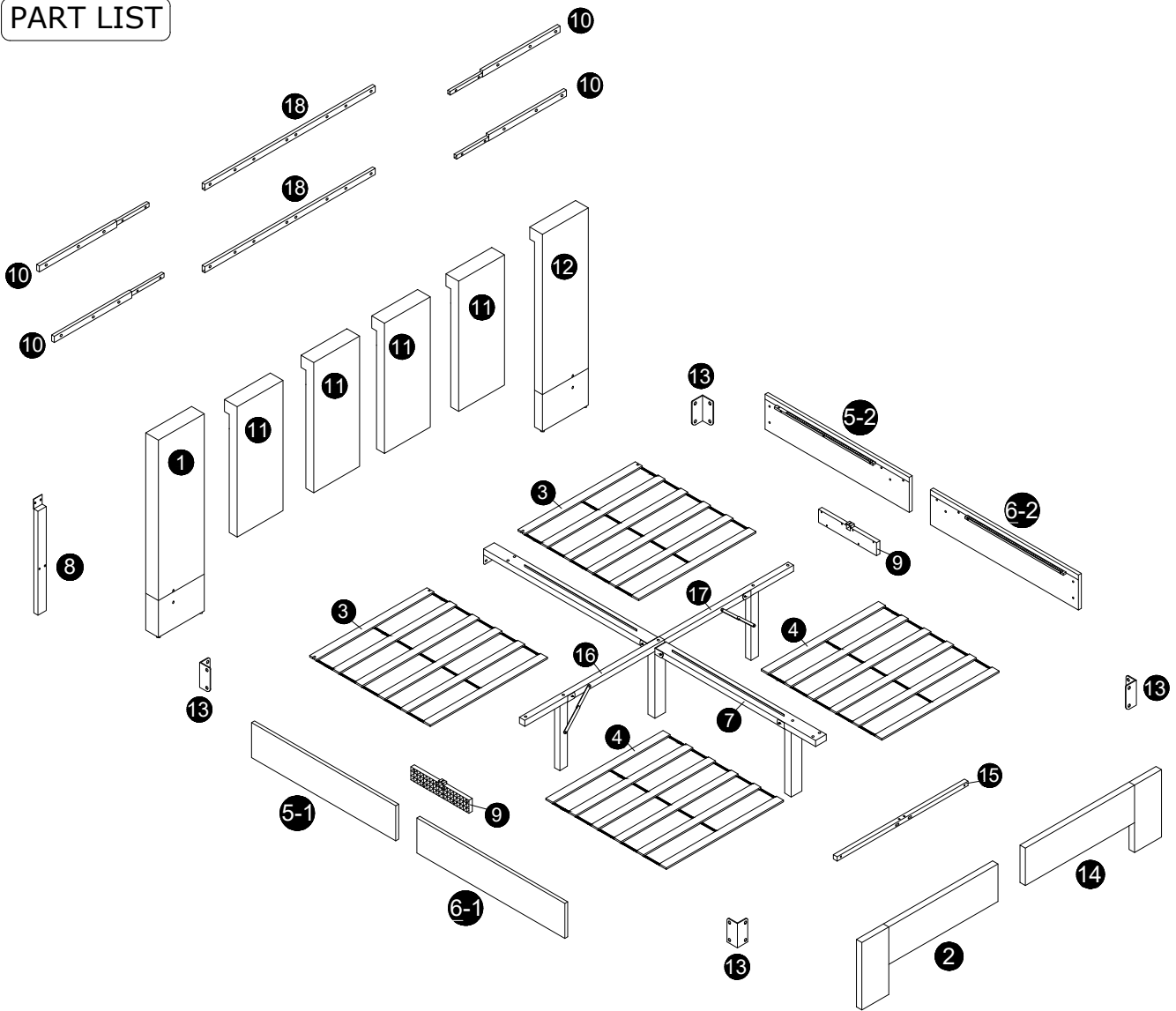

**Components of Carton A**

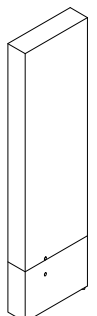
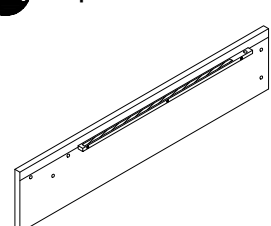
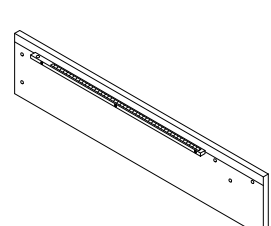
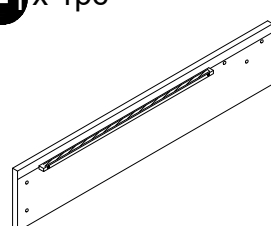
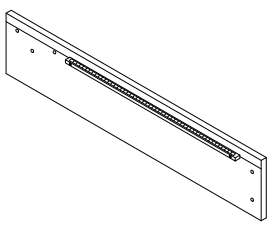
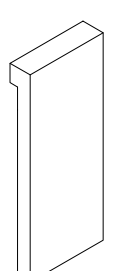
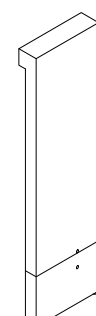
<p><b>1</b> x 1pc</p> 	<p><b>5-1</b> x 1pc</p> 	<p><b>5-2</b> x 1pc</p> 	<p><b>6-1</b> x 1pc</p> 
<p><b>6-2</b> x 1pc</p> 	<p><b>11</b> x 4pcs</p> 	<p><b>12</b> x 1pc</p> 	

## Components of Carton B

**2** x 1pc

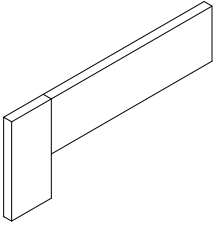

**3** x 2pcs

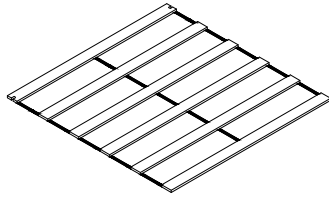

**4** x 2pcs

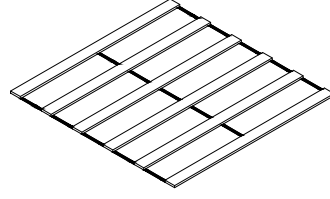

**7** x 1pc

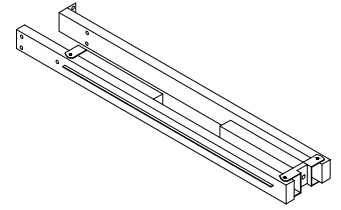

**8** x 1pc



**9** x 2pcs

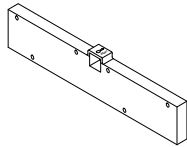

**10** x 4pcs

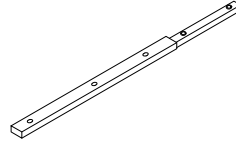

**13** x 4pcs



**14** x 1pc

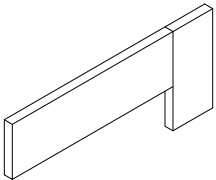

**15** x 1pc

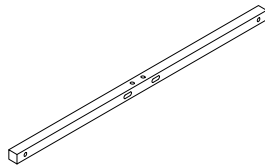

**16** x 1pc

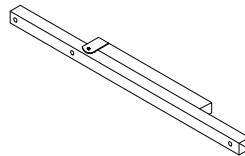

**17** x 1pc

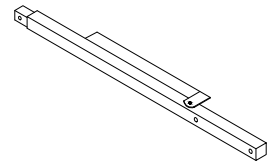

**18** x 2pcs

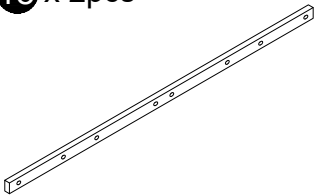

### HARDWARE LIST



**H1** M5 x 1pc



**H2** M8x20mm x 22pcs



**H3** M8x40mm x 18pcs



**H4** M8x50mm x 27pcs



**H5** M8 x 28pcs



**H6** M8x22mm x 28pcs



**H7** M8x30mm x 2pcs



**H8** M8x60mm x 3pcs

**Please ensure to thoroughly inspect the small inner cardboard box containing the hardware, which are tied with a red string, before disposing of the box.**

1

As shown in the diagram, align the screws with the corresponding holes and pre-fix them. Then, tighten each screw separately.

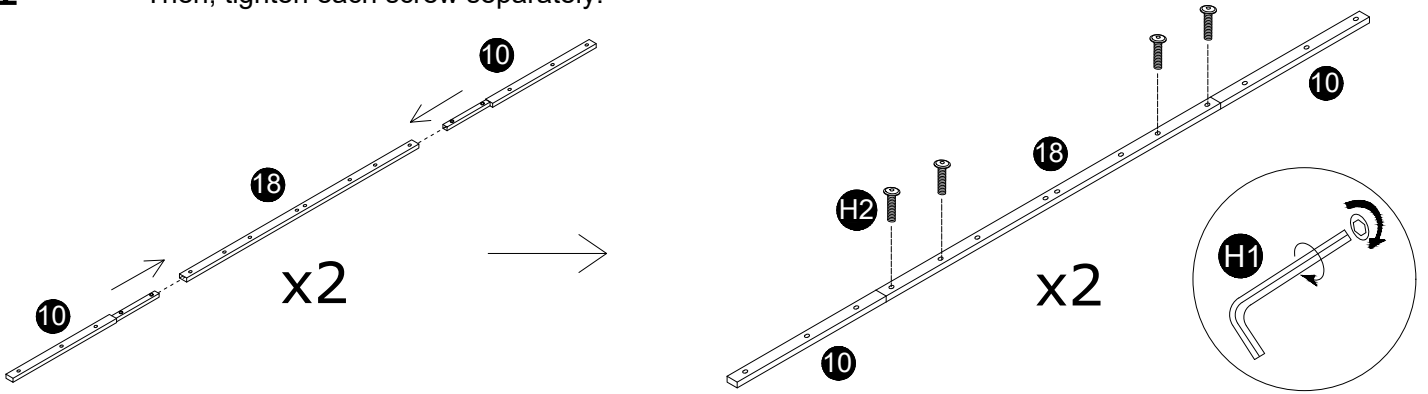

2

Loosely screw parts 1, 12, and 10 together to facilitate inserting part 11 between 1 and 12. Tightening the screws too much will make it difficult to insert part 11.

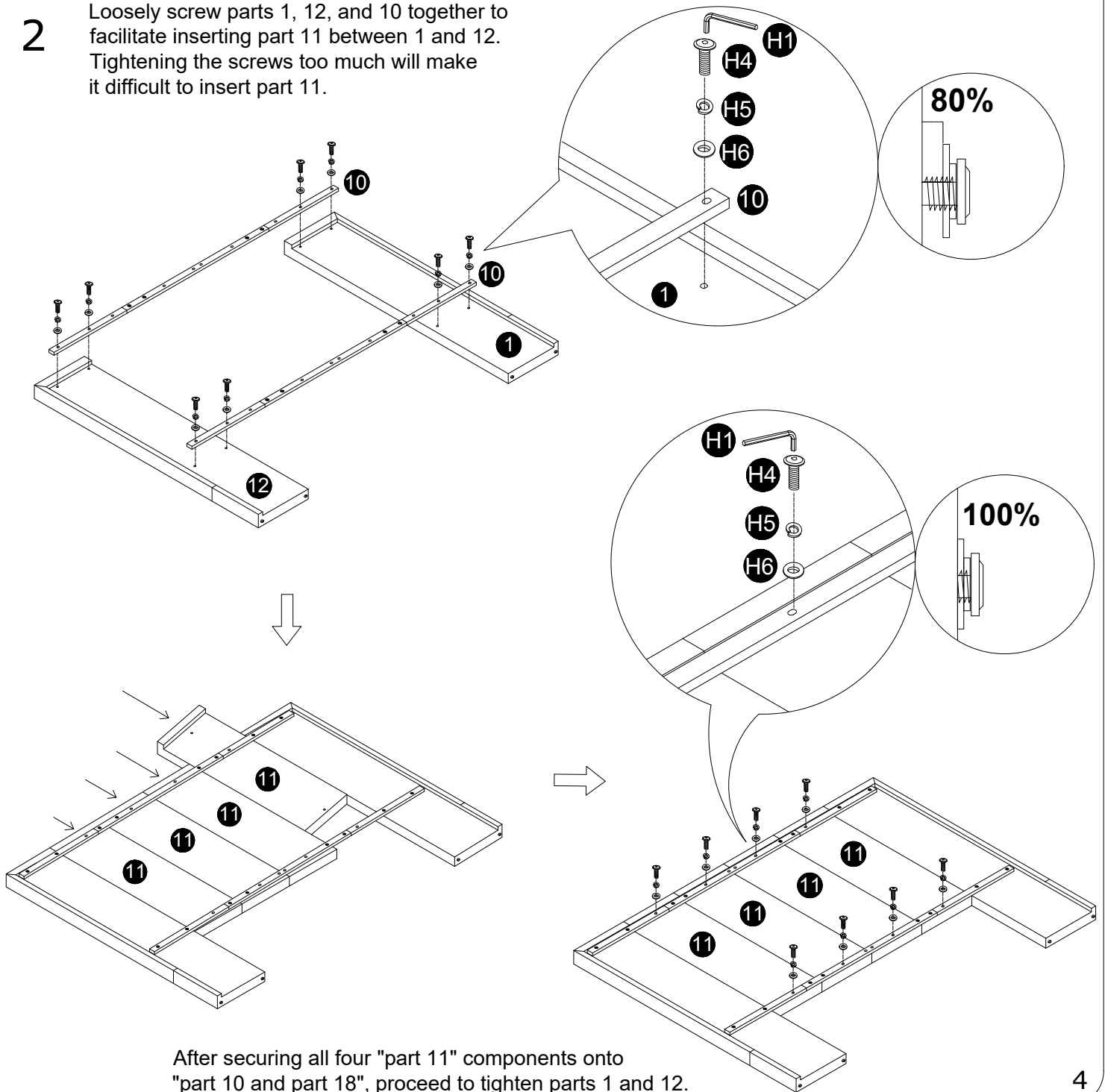

After securing all four "part 11" components onto "part 10 and part 18", proceed to tighten parts 1 and 12.

3

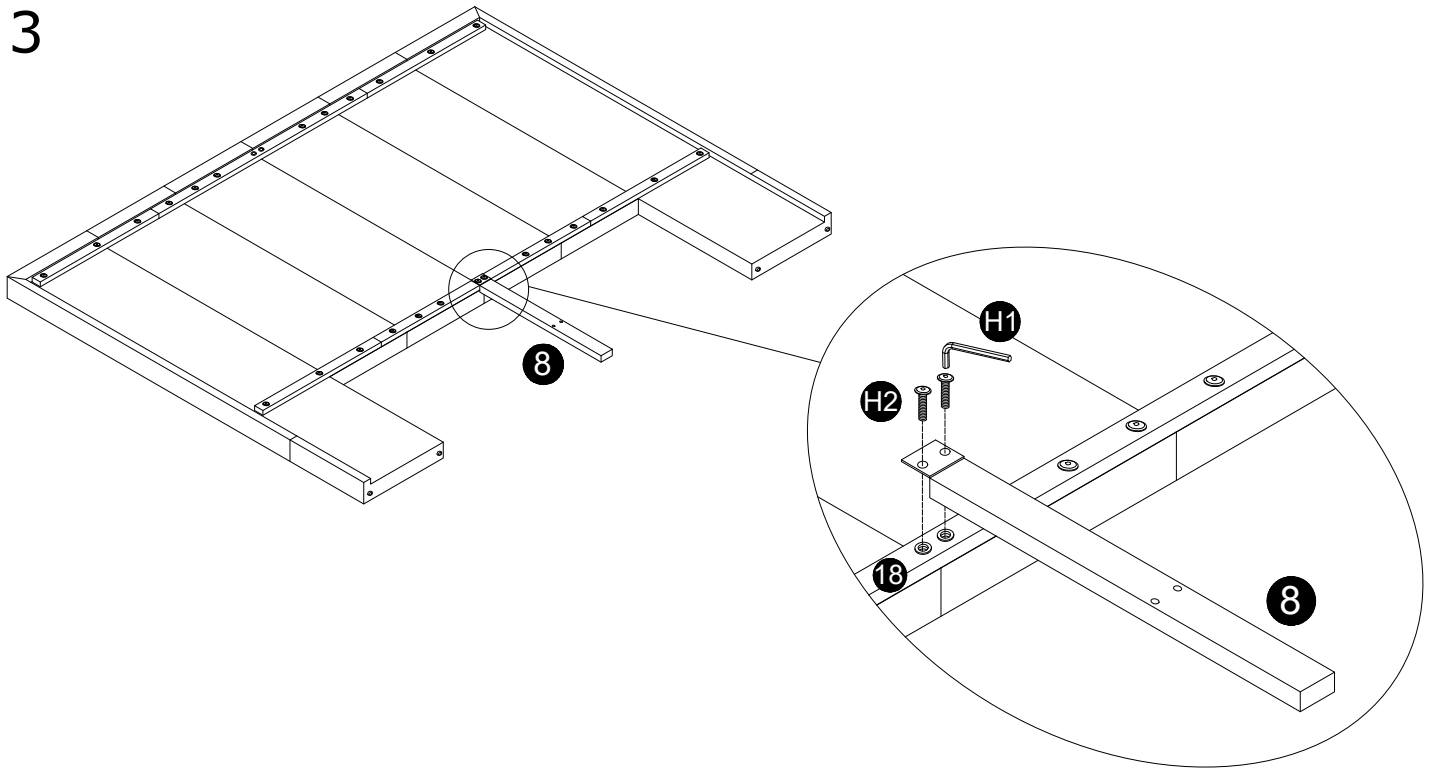

4

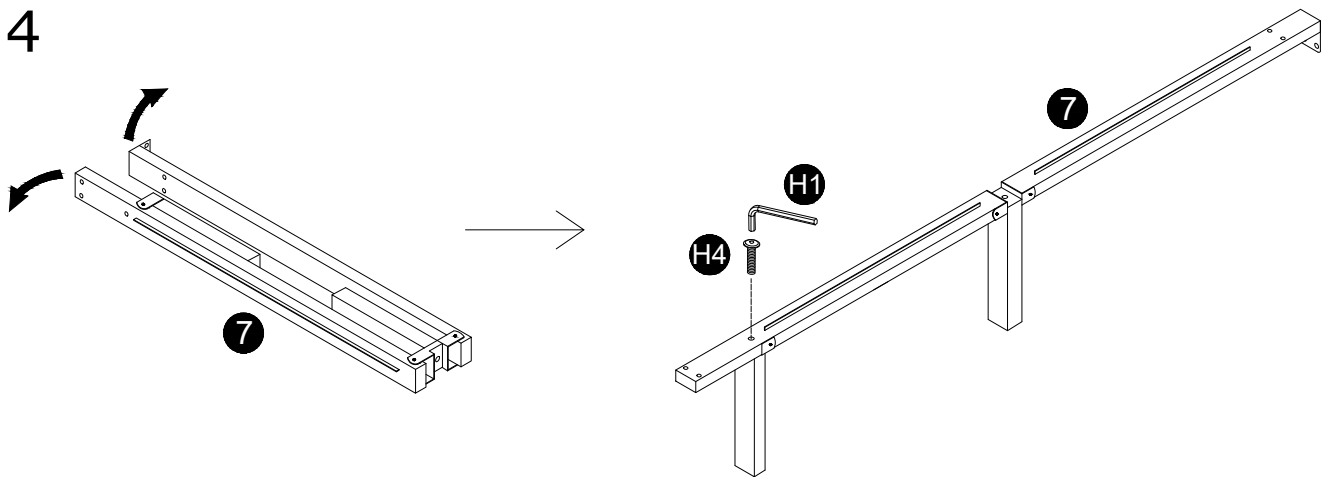

5

BEWARE OF CLAMP HAND

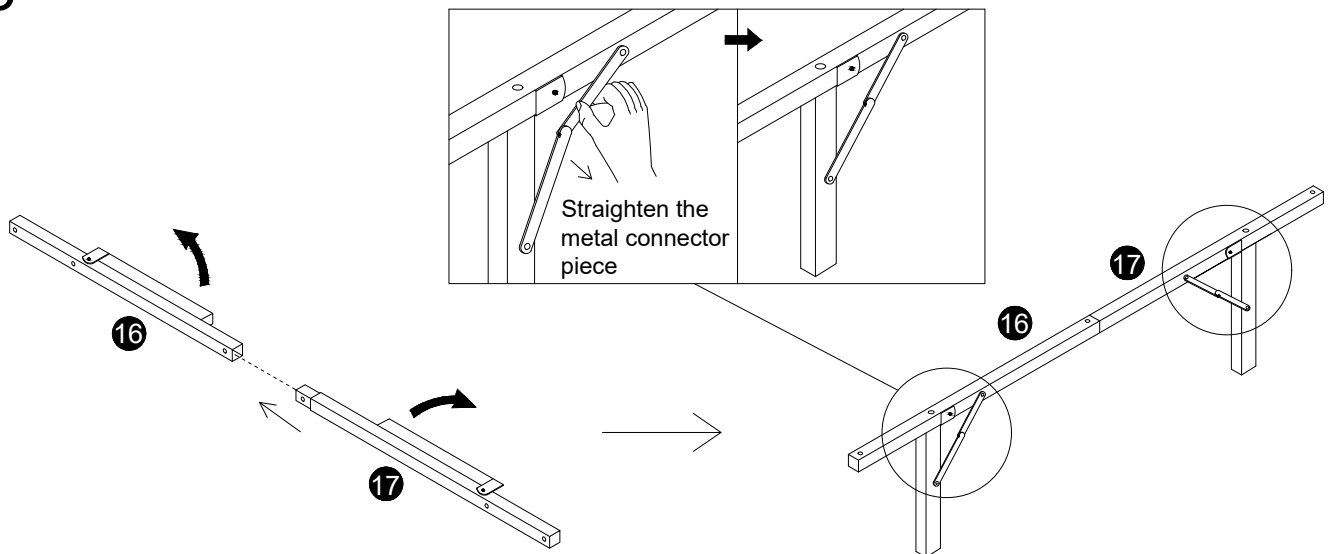

6

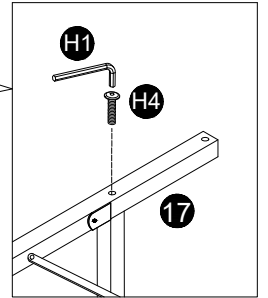
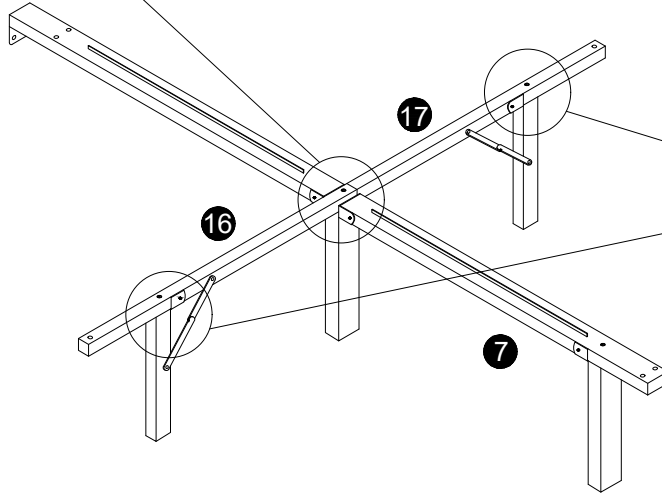
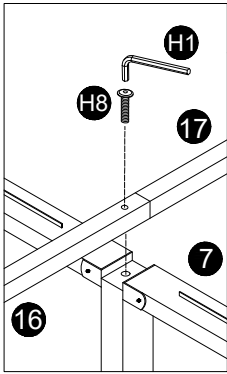

7

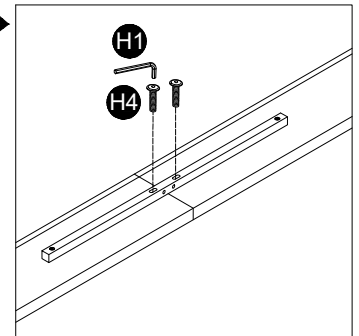
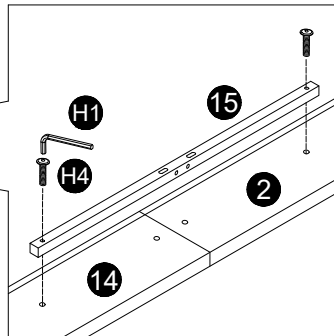
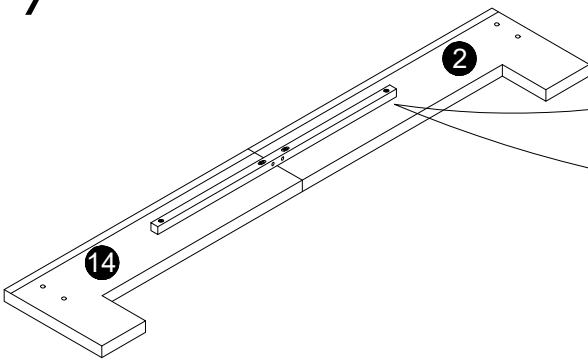

8

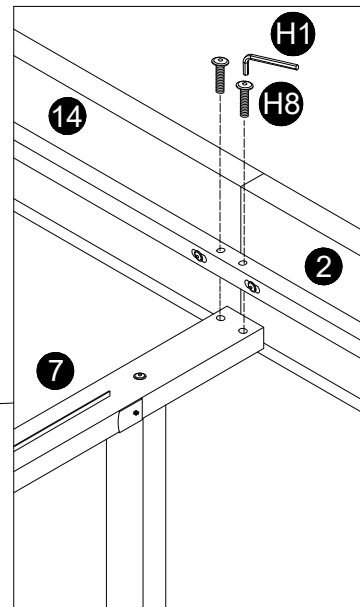
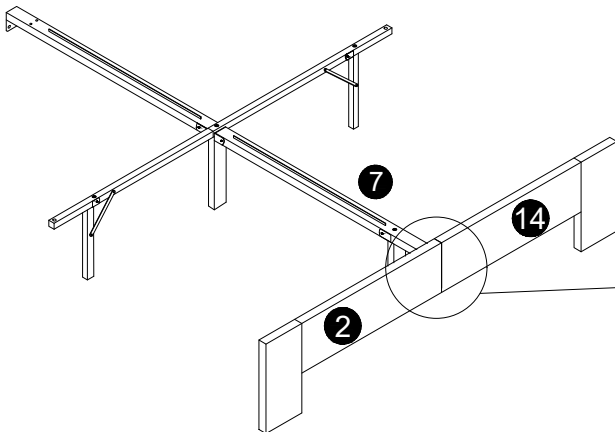

9

**Important:** part 9 , following the "INNER"

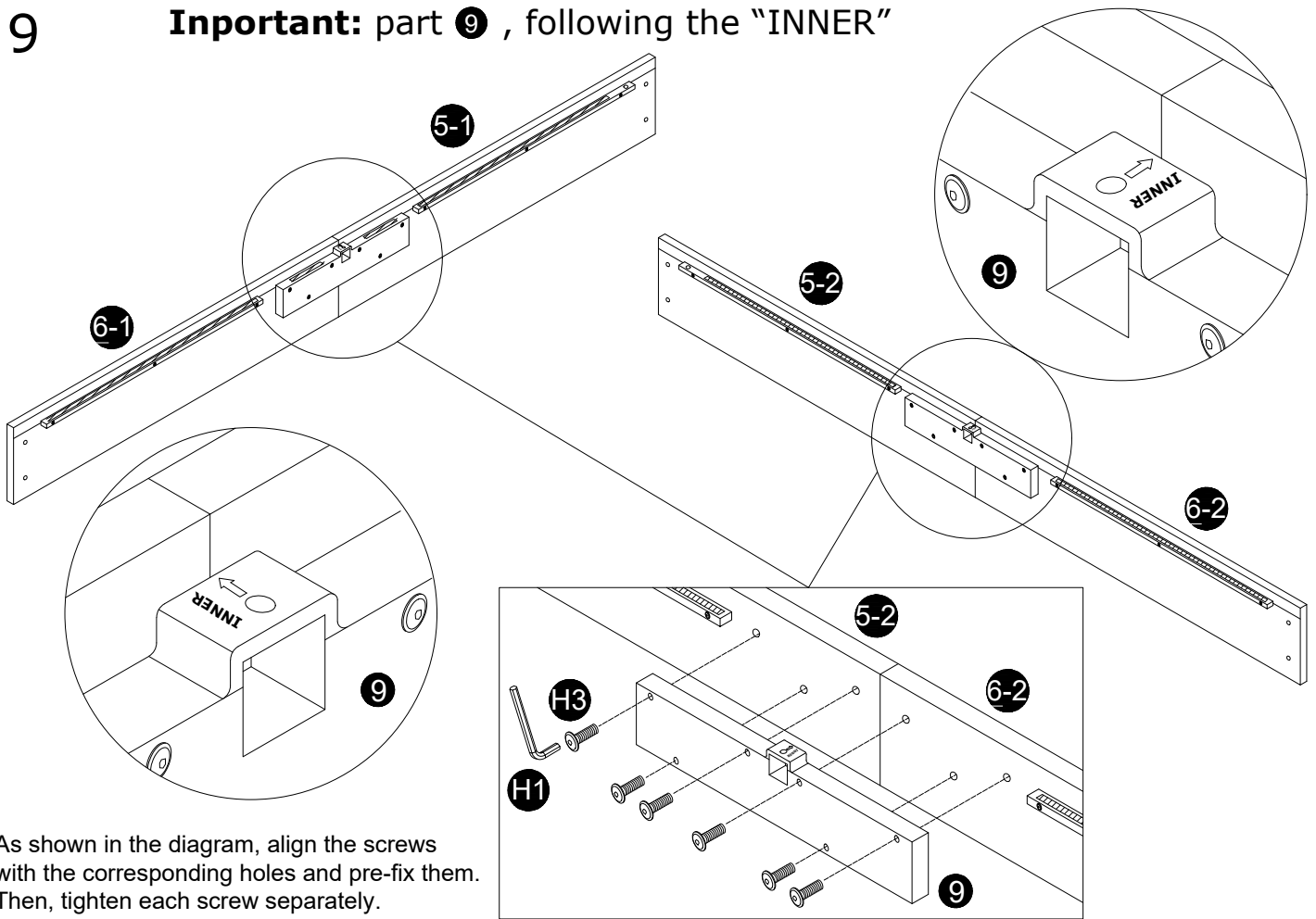

10

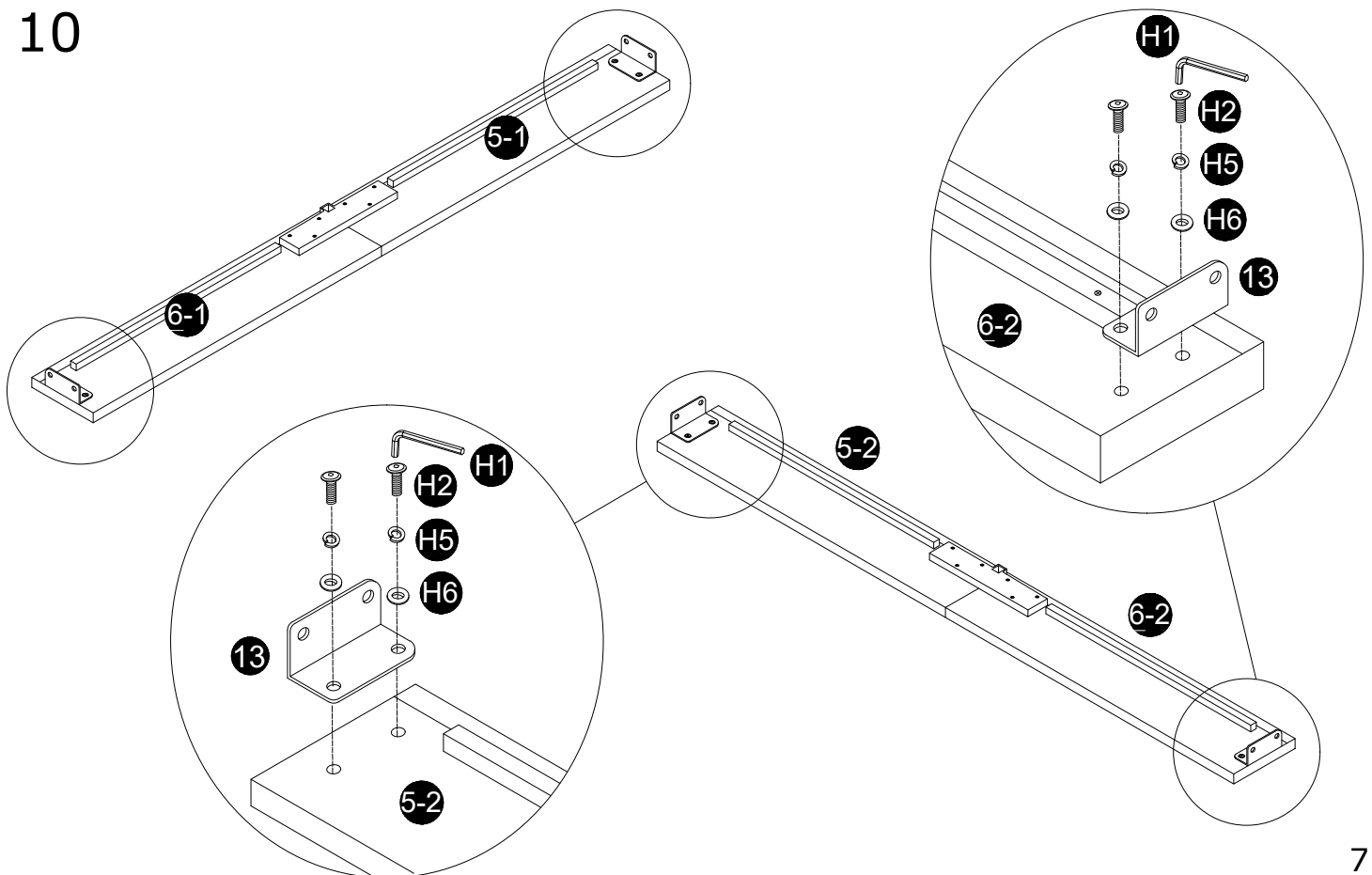

11

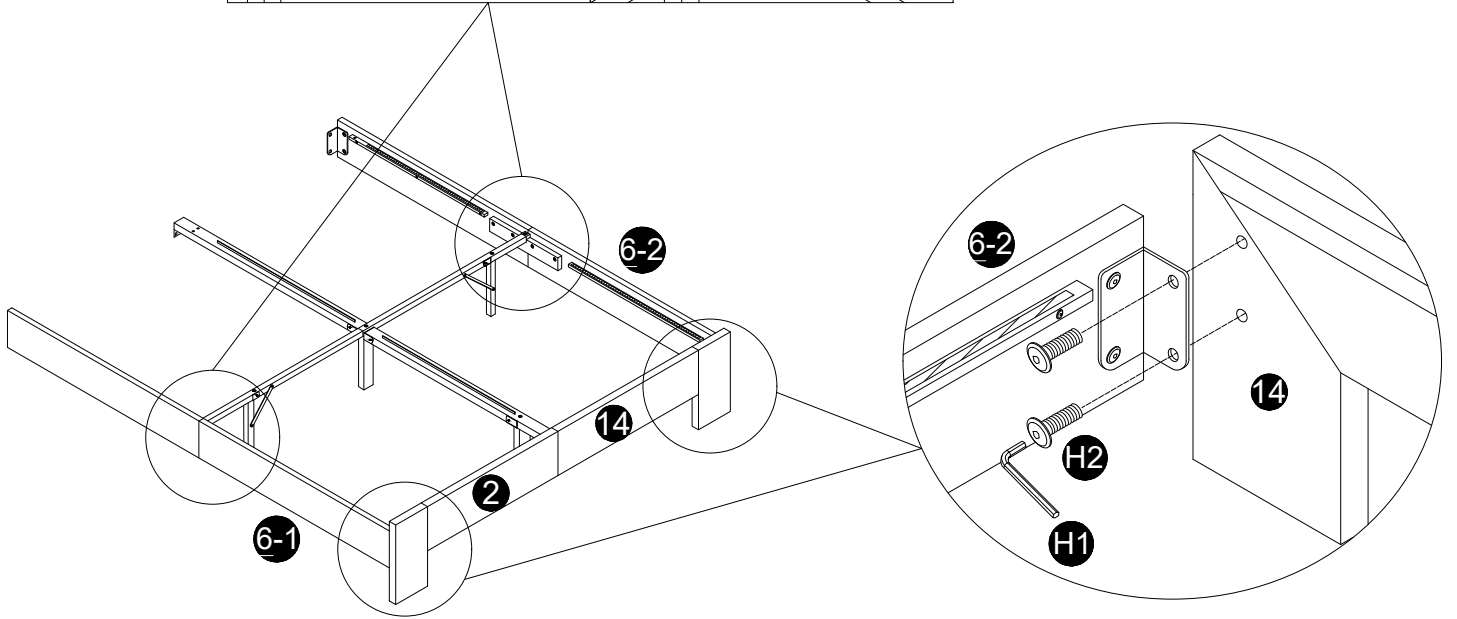
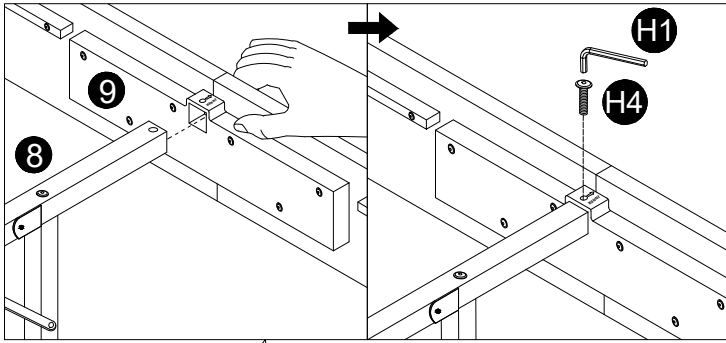

12

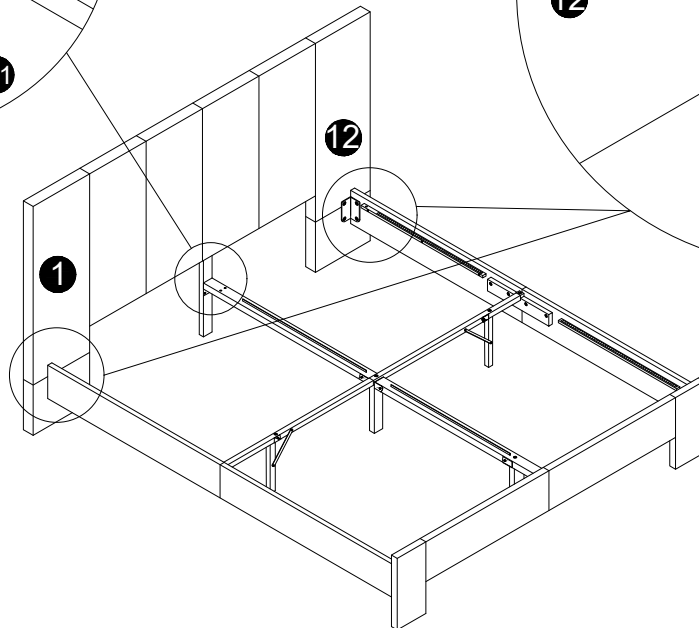
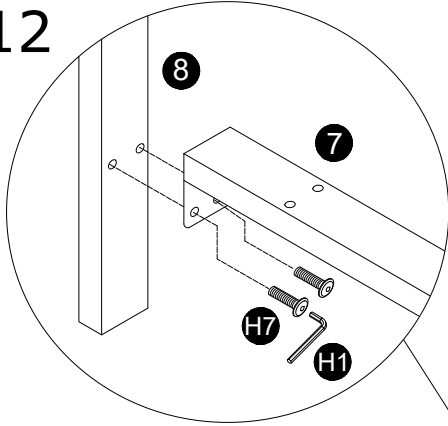

13

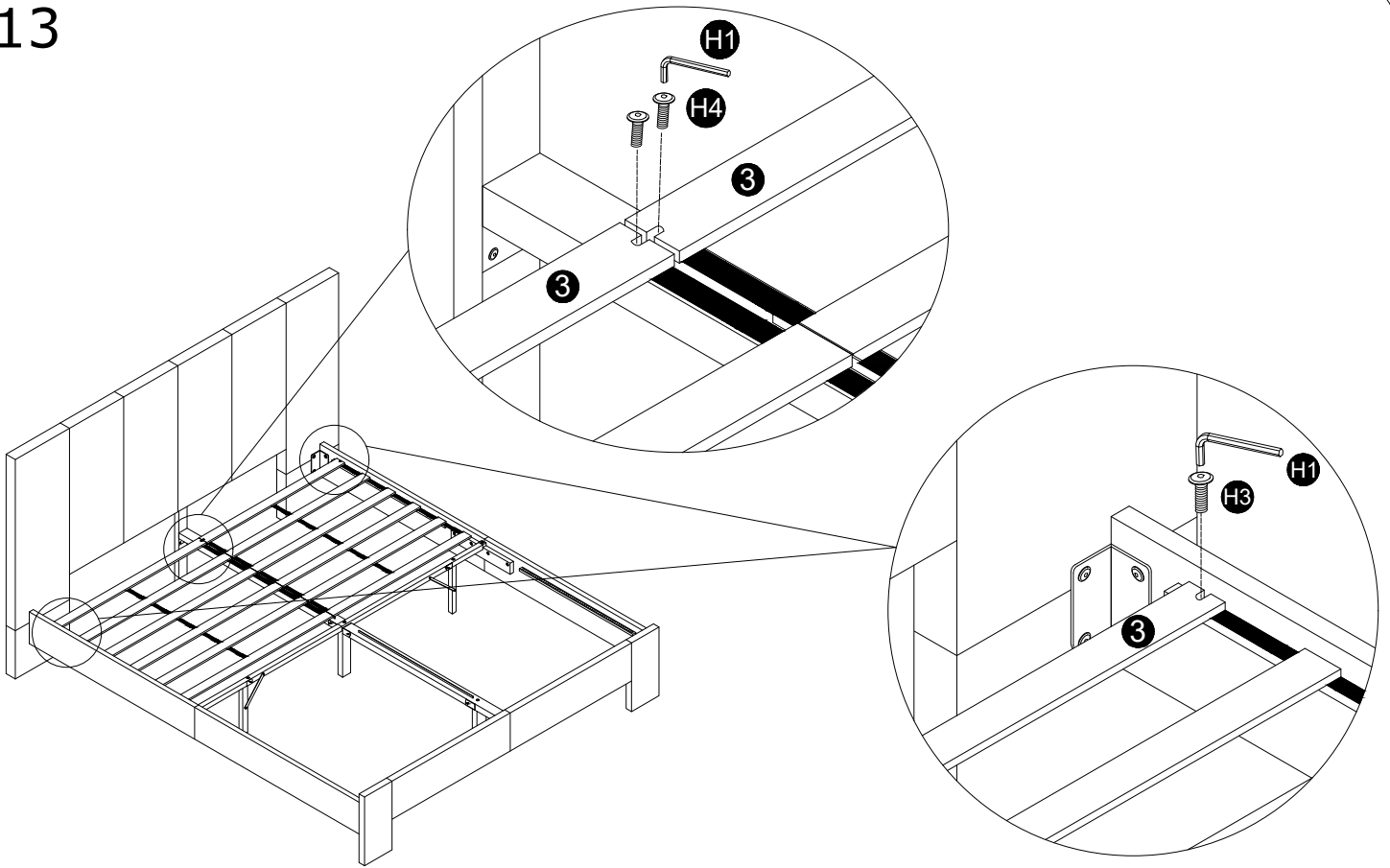

14

