

ASSEMBLY INSTRUCTION

KING HEADBOARD

NO	PART LIST	QTY
1	HEADBOARD WITH LABEL "1"	1pc
2	HEADBOARD WITH LABEL "2"	2pcs
3	HEADBOARD LEG	2pcs
4	HEADBOARD SUPPORT (SHORT)	1pc
5	HEADBOARD SUPPORT (LONG)	1pc
NO	HARDWARE LIST	QTY
A	JCBC SCREW M8 x 35mm	9pcs
B	SPRING WASHER M8 x 14mm	9pcs
C	FLAT WASHER M8 x 22mm	9pcs
D	JCBC SCREW M6 x 50mm	4pcs
E	SPRING WASHER M6 x 12mm	9pcs
F	FLAT WASHER M6 x 19mm	13pcs
G	HEX NUT (M6)	4pcs
H	L - KEY M4 x 65mm	1pc
I	L - KEY M5 x 65mm	1pc
J	JCBC SCREW M6 x 35mm	5pcs
K	PANHEAD M4 x 28mm	6pcs

STEP 1

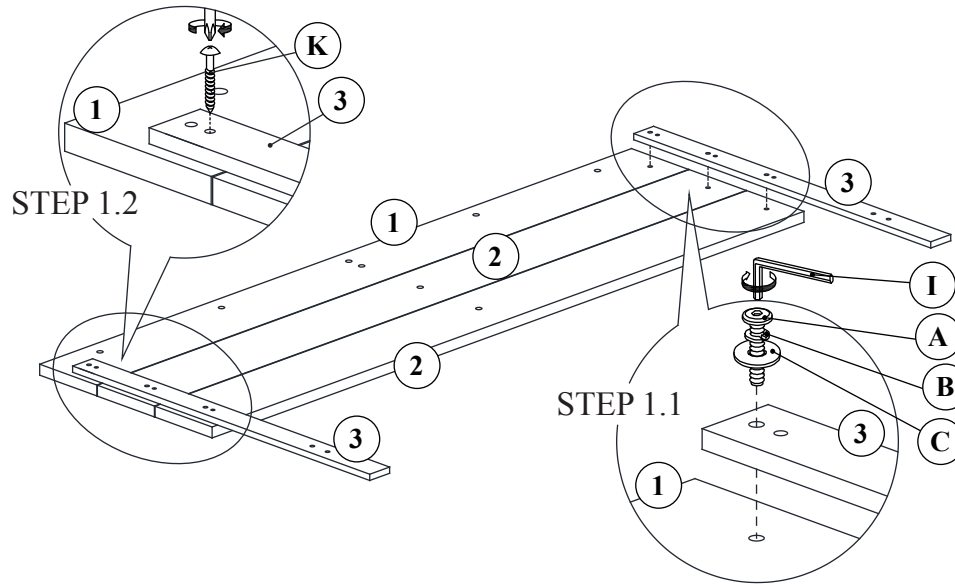

STEP 2

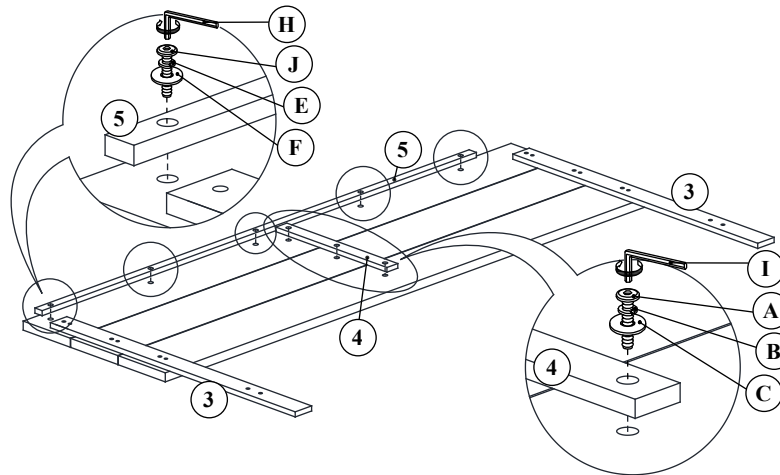

STEP 3

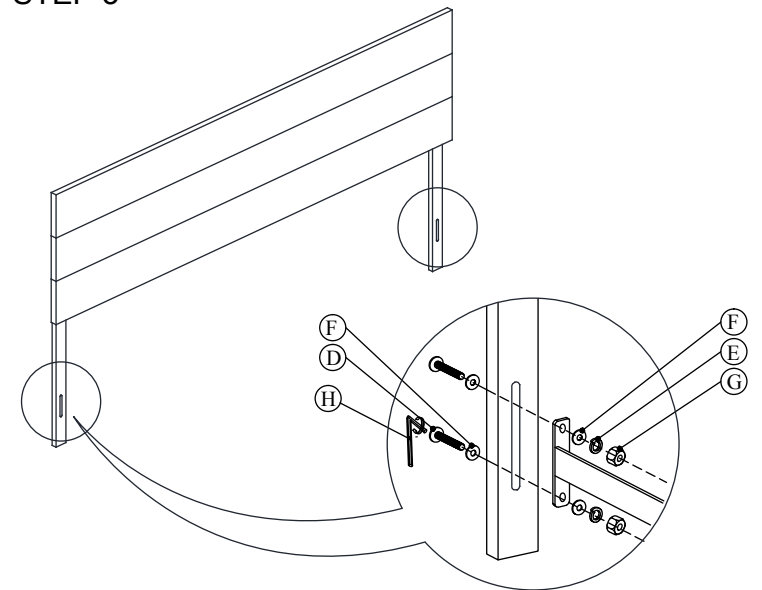

NOTE: AFTER A FEW DAYS OF ASSEMBLY, IT WILL HAVE ACCLIMATIZED TO THE ENVIRONMENT. PLEASE TIGHTEN ALL HARDWARE. CHECK TIGHTNESS OF ALL SCREWS EVERY 6-8 WEEKS.