

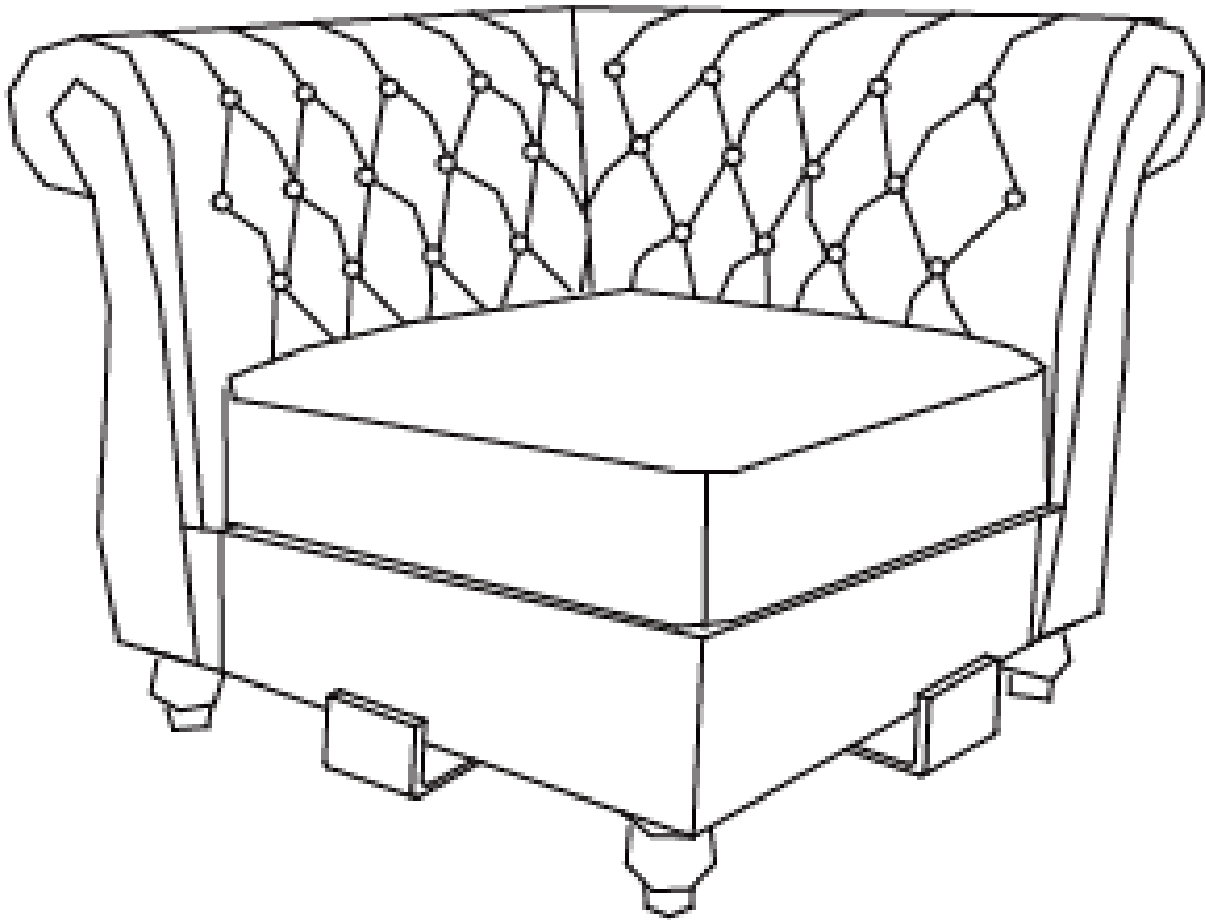

Assembly Instructions

Caution: You must read this before you proceed



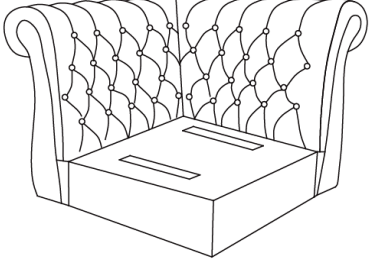
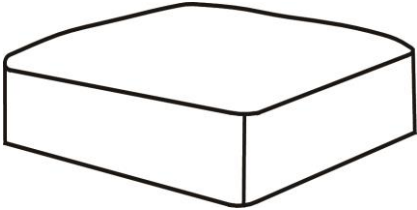

Corner Seat

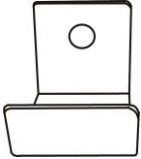

Parts List





Label	Picture	Description	QTY
A	 A line drawing of a tufted corner seat. The seat has a high, tufted backrest and a square base. The tufting is arranged in a grid pattern on the backrest.	Corner Seat	1
B	 A line drawing of a square seat cushion. It is a simple rectangular block with rounded corners and a slightly raised edge.	Seat Cushion	1
C	 A line drawing of a leg. It is a simple, rounded, bulbous shape with a small vertical post extending from the top center.	Leg	4
D	 A line drawing of a metal bracket. It consists of a rectangular base with a circular hole in the center, and a vertical post extending upwards from the center of the base.	Metal Bracket	2

Hardware

Label	Picture	Description	QTY
①		Bolt (M8*25mm)	3
②		Washer(M8)	3
③		Gasket	7
④		Allen Wrench(M8)	1
⑤		Spring Washer(M8)	3

Assembly Preparation

Before Beginning Assembly:

-  X3
-  X3
-  X3
-  X7
- 

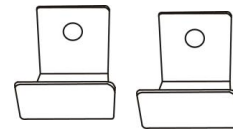
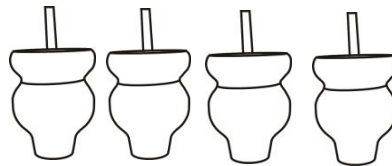
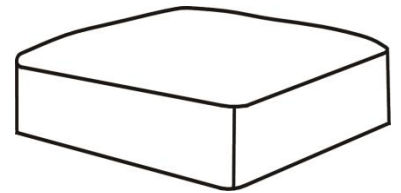
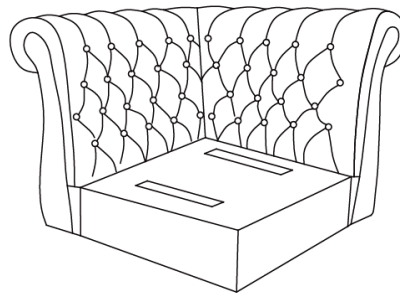

- Read instructions, cover to cover-



- Have 2 adults on hand for assembly-



- Do not assemble on flooring or carpet-



- Assemble on a clean non-marring surface (packing foam)-



- Save all packaging until finished-

Assembly Steps

Overview

Corner Seat(A)

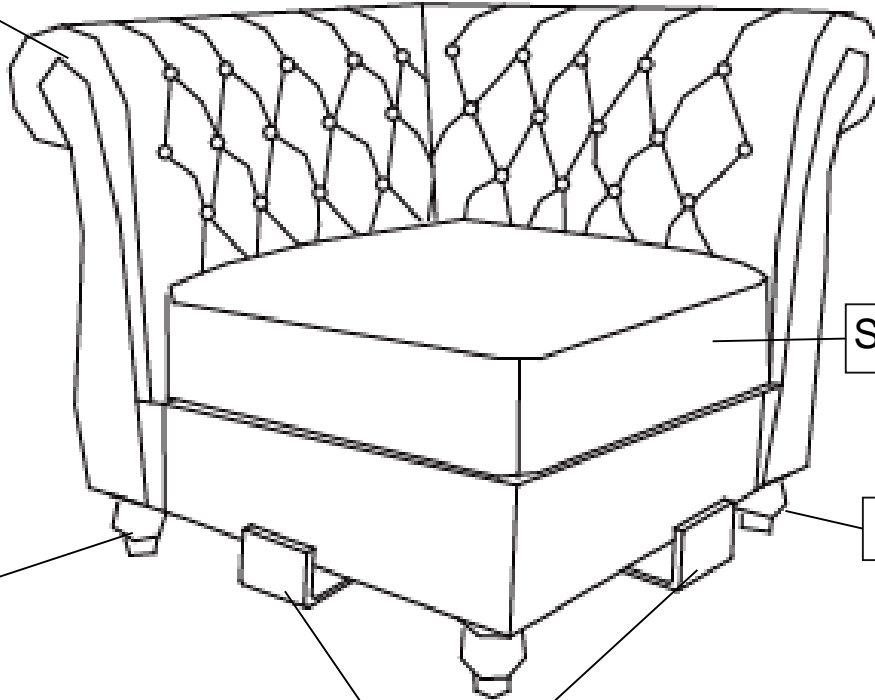

Seat Cushion(B)

Leg(C)

Leg(C)

Metal Bracket(D)



FRONT FACING

This Corner Seat has multiple parts and may require up to 30 minutes to assemble. To give you an overview of the Corner seat parts, the above picture is to help you put the various parts into perspective. Please read through the instructions below to familiarise yourself with the parts and steps before assembly.

Note: It is recommended that you have an adult partner to assist during the entire assembly process.

Step 1

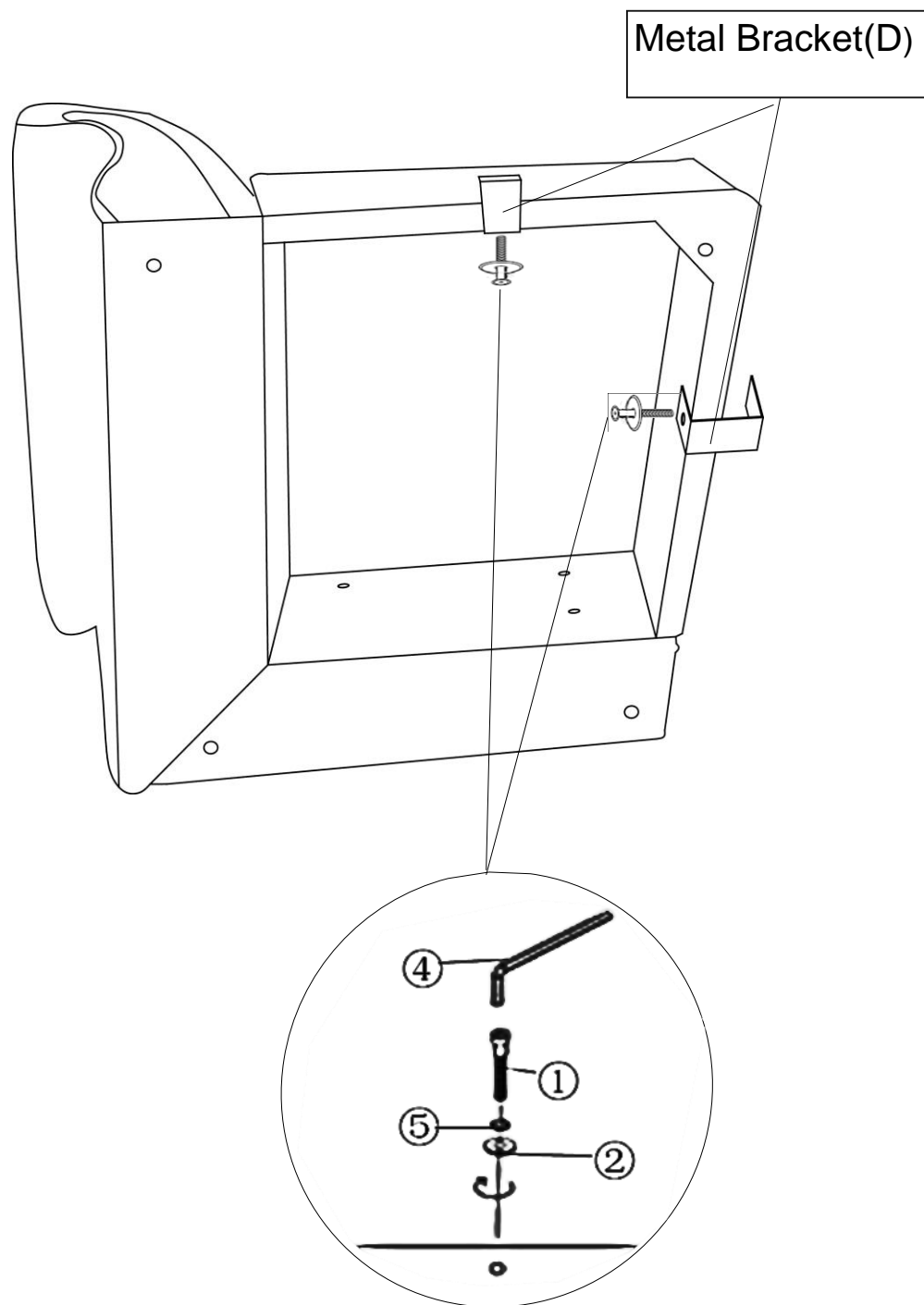

Attach the Metal Brackets(D) to the Corner Seat using Bolts(①), Spring Washers(⑤), and Washers(②) with the Allen Wrench(④) .
Tighten the Bolts fully in a sequential manner.

Step 2

Use Gasket(③) to achieve stability

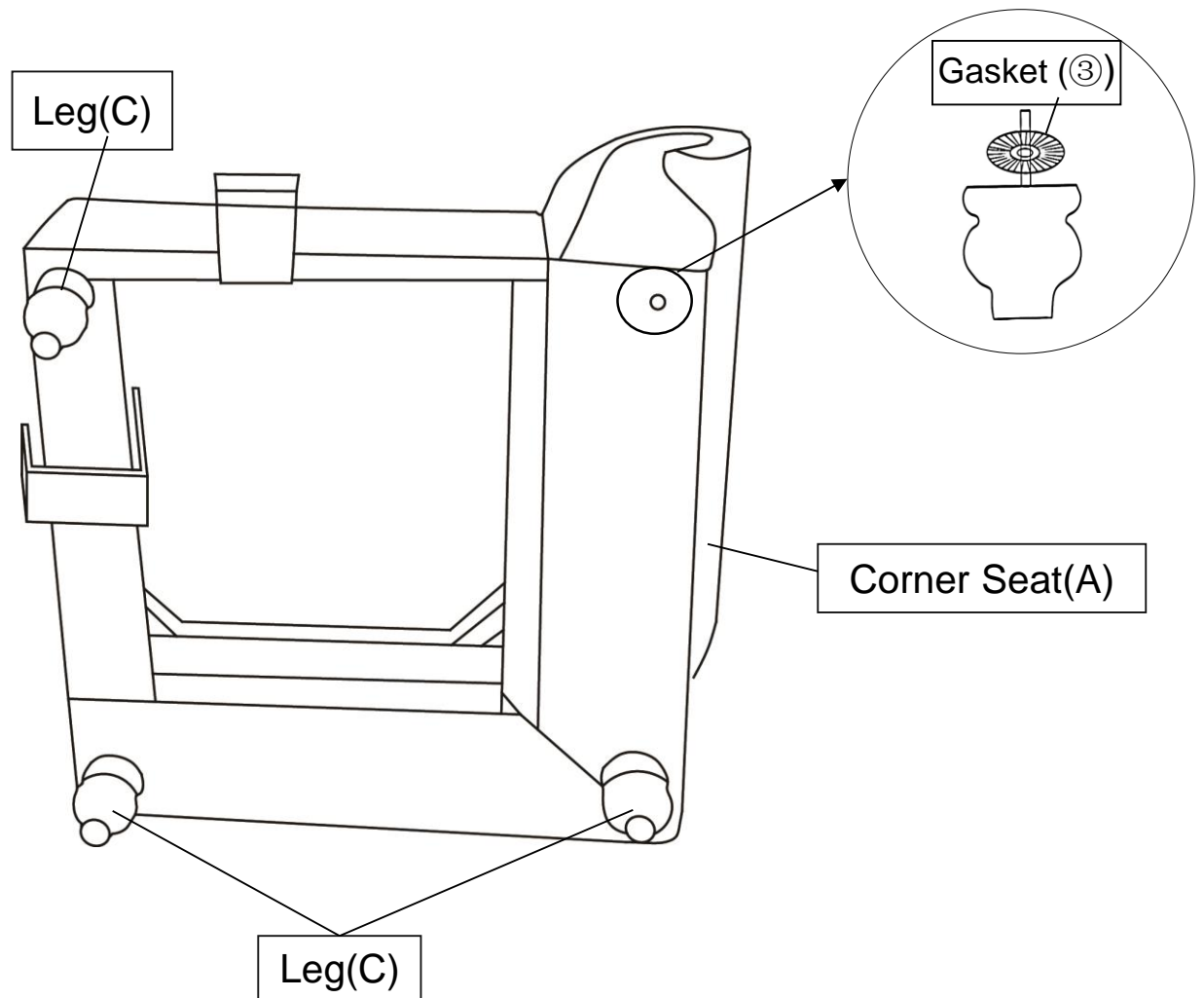

Install the Legs(C) at the bottom of the Corner Seat by placing one Gasket(③) on the threaded stem.

Then insert the threaded stem into the threaded mounting position at the corner of the Corner Seat.

Tighten by turning the Leg clockwise.

Repeat the same step to install the remaining three Legs.

Note: The use of Gaskets are OPTIONAL and are especially useful to help alleviate slight wobbleness. Some Legs may need more than one whilst some legs may not need any.

Step 3

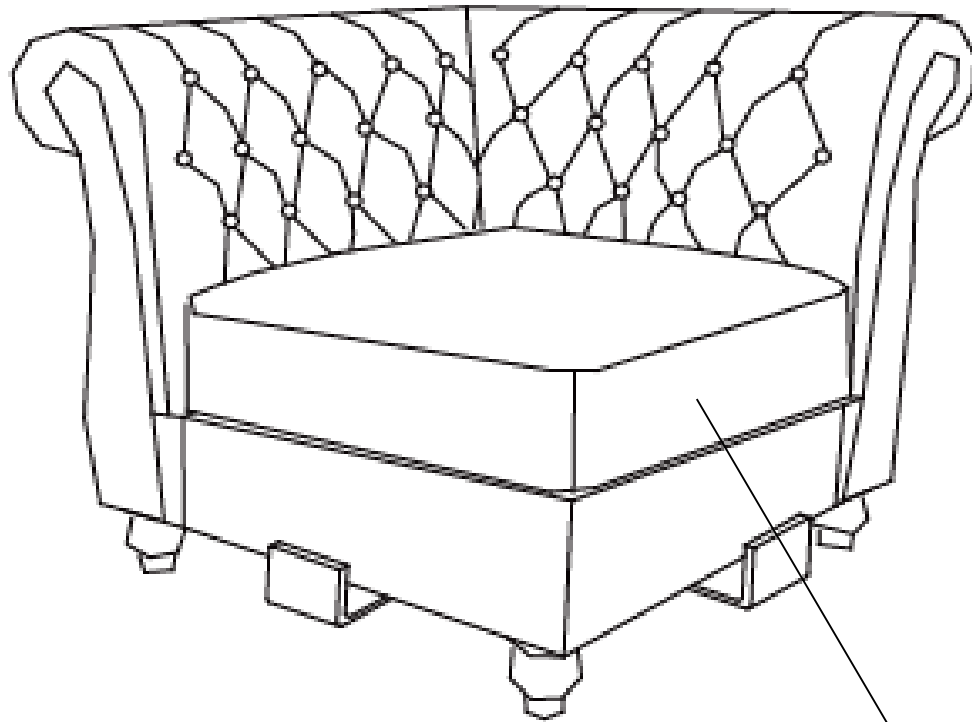

Seat Cushion(B)

Place the Seat Cushion(B) onto the Corner Seat.
Your Corner Seat is ready for use.

This Corner Seat can only be used on a flat, level surface.

Additional Steps

Step 1

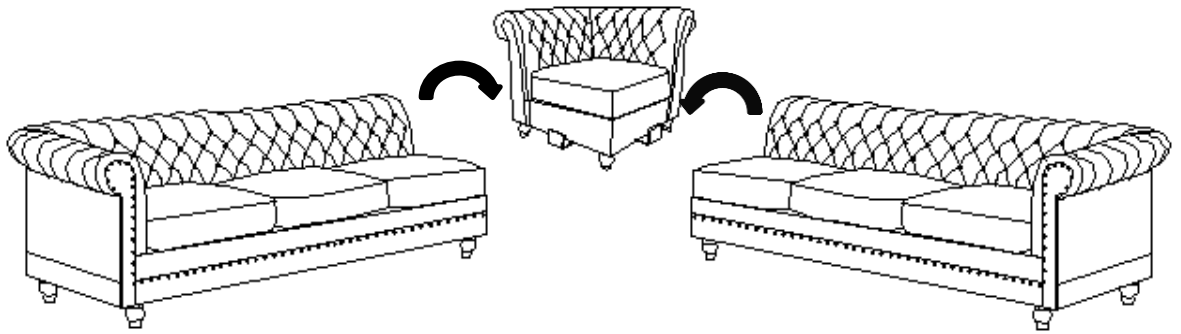

Connect the Sofas by intersecting the metal brackets.
Make sure all parts are connected and securely locked into position.

Step 2

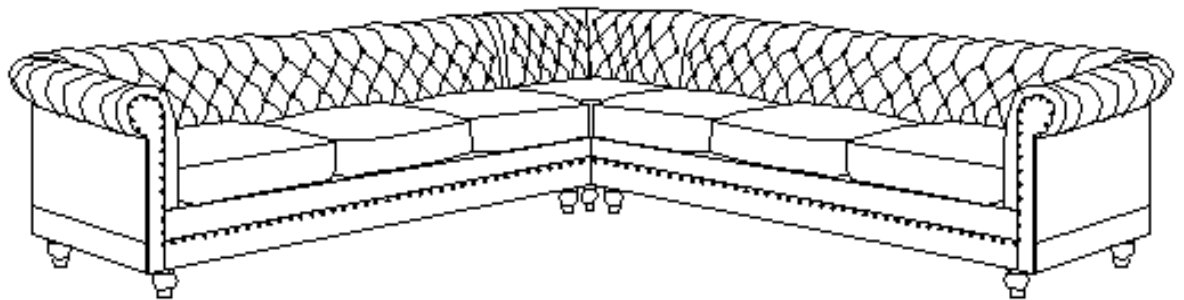

Your Sofa Set is ready for use.
This Sofa Set can only be used on a flat level surface.

Care & Maintenance



- Furniture may scratch floors. We recommend using furniture pads to protect your floors.



- Do not put hot items directly on furniture surface.



- Do not clean furniture with harsh cleansers or polish.



- Do not place furniture under direct sunlight.



- Do not place furniture near heating or cooling vents.



- Do not write on furniture without a padded barrier to protect the surface.



- Do not place furniture outside . For indoor use only.



- Not for commercial use. For residential use only.



- Stains may be removed with mild soap solution and damp cloth.



- Children should not climb or jump on the furniture.



- Dust and pick-up spills using a clean, non-colored, lint-free cloth.