



ASSEMBLY INSTRUCTIONS



Thank you for purchasing this product. Please take time to read and follow instructions below. Check that you have all parts and hardware before assembly. Parts apparently missing are often found in packing materials. If you do not have all parts listed, call us and they be sent to you immediately



It is recommended to install protective pads under all legs and supports to avoid damage or scratches when placing furniture on a wood floor or other hard surface, and to limit indentation and prevent discoloration if placing on carpet.

PARTS LIST			
NO.	SKETCH	DESCRIPTION	Q'TY
A		BACK	1PC
B		LEG	1PC

HARDWARE LIST				
NO.	DESCRIPTION	SIZE	SKETCH	Q'TY/ Q'TÉ
1	BOLT	M6x30mm		4PCS
2	ALLEN KEY	5mm		1PC

Step 1

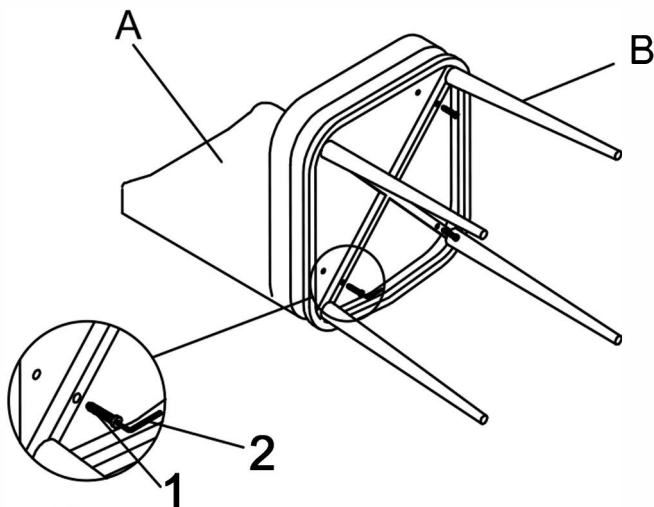

Step 2



ASSEMBLY COMPLETED

DO NOT TIGHTEN BOLTS UNTIL COMPLETELY ASSEMBLED.

HARDWARE MAY LOOSEN OVER TIME. PERIODICALLY CHECK TO MAKE SURE ALL CONNECTIONS ARE TIGHT.