

## NOTICE

- \* Please make sure that you have all parts indicated and they are in good condition before you begin assembly of this item. Refer to part list and hardware list below for guidance.
- \* This item should be assembled on a soft surface to prevent scratching the finish during assembly.
- \* This item may require periodic tightening.













## PREPARATION

- \* Before beginning assembly of product, make sure all parts are present. Compare parts with part contents list and hardware contents list.
- \* If any part is missing or damaged, do not attempt to assemble the product.
- \* Estimated Assembly Time: 10 minutes.
- \* Tools Required for Assembly (included): Allen Key

## CARE AND MAINTENANCE

- \* Spot clean using a mild water-free solvent. Only a professional cleaner should undertake a complete overall cleaning.
- \* The use of steam or water-based cleaners may cause excessive shrinking or staining.

### Part List and Hardware List

PIECE	DESCRIPTION	PICTURE	QUANTITY
A	Back		1X
B	Seat		1X
C	Arm Frame		2X
D	Back support		2X
HW1	Split Lock Washer(M8)		6X
HW2	Flat Washer(M8)		6X
HW3	Socket Screws 8*1.25*40MM		6X
HW4	Allen Key(M8)		1X
HW5	Split Lock Washer(M6)		8X
HW6	Flat Washer(M6)		8X
HW7	Socket Screws 6*1.05*20MM		8X
HW8	Allen Key(M6)		1X
HW9	Metal plate		4X

**Dimensions:28.7"WX34.6"DX28.9"H**

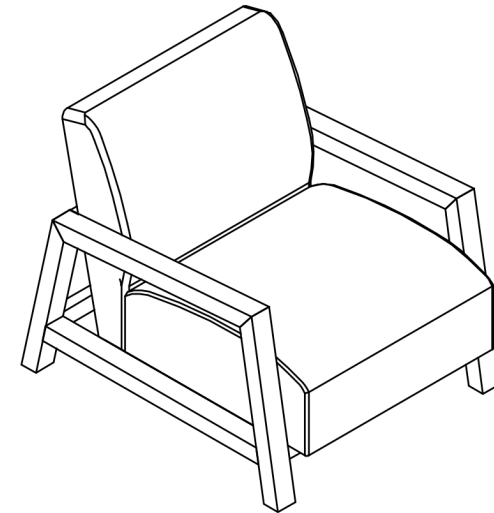

**Weight Capacity: 275 lbs**

**Warning: Do not stand on Chair**

**Warning: Do not over torque bolts**

# PREPARATION

- \* Before beginning assembly of product, make sure all parts are present. Compare parts with part contents list and hardware contents list.
- \* If any part is missing or damaged, do not attempt to assemble the product.
- \* Estimated Assembly Time: 10 minutes.
- \* Tools Required for Assembly (included): Allen Key

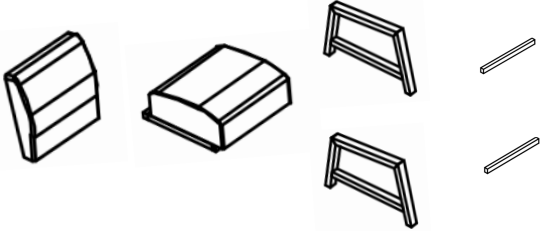
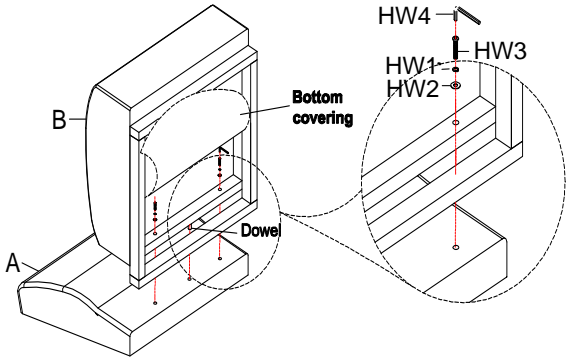
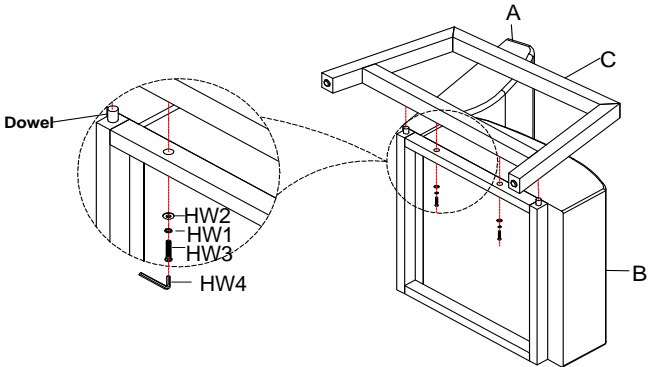
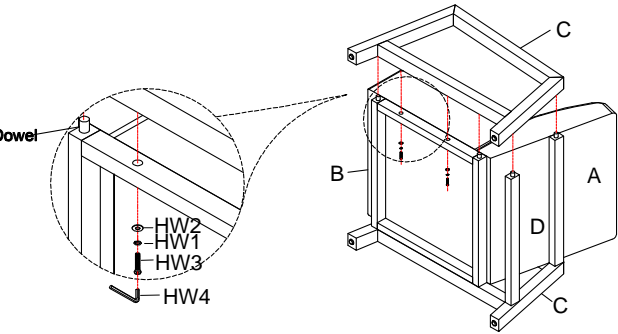
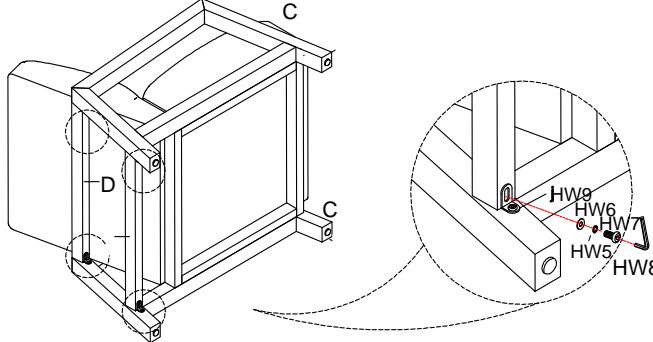
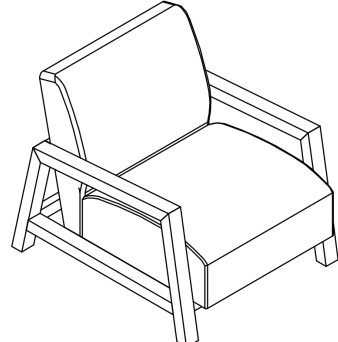
		
<p><b>STEP1</b> OPEN TO TAKE OUT THE BODY AND HARDWARE</p>	<p><b>STEP2</b> ATTACH THE SEAT B TO BACK A AS SHOWN. SECURELY TIGHTEN ALL BOLTS WITH ALLEN WRENCH HW4.</p>	<p><b>STEP3</b> ATTACH THE ONE ARM FRAME C TO STEP2 PART AS SHOWN. SECURELY TIGHTEN ALL BOLTS WITH ALLEN WRENCH HW4.</p>
		
<p><b>STEP4</b> INSERT BACK SUPPORT TO THE OTHER ARM FRAME. LOOSELY ATTACH THE ARM FRAME C TO STEP3 PART AS SHOWN. SECURELY TIGHTEN ALL BOLTS WITH ALLEN WRENCH HW4.</p>	<p><b>STEP5</b> ATTACH METAL PALTE HW9 TO STEP4 PART AS SHOWN. SECURELY TIGHTEN ALL BOLTS WITH ALLEN WRENCH HW8.</p>	<p>TURN THE CHAIR TO AN UPRIGHT POSITION. ASSEMBLY IS COMPLETE.</p>