



Manufactured by: Backyard
Discovery
3305 Airport Drive, Pittsburg,
KS 66762 800-856-4445

Basepoint Business Centre: Rivermead Drive, Westlea, Swindon SN5 7EX Phone:
0800-118-2476 J.P. Coenstraat 7, The Bridge, The Hague, 2595 WP, Netherlands Phone: 08005678990

12x12 BARRINGTON GAZEBO

MODEL # : 2306226



Please visit www.backyarddiscovery.com
For the most up to date assembly manual, to register your product, or to order
replacement parts *Para obtener instrucciones en español, visite*
www.backyarddiscovery.com



EASY STEP-BY-STEP
3D INTERACTIVE INSTRUCTIONS
DOWNLOAD THE FREE APP



Made in China

INS-2306226-A-12X12 BARRINGTON GAZEBO-ENG 9-23-2024

OWNER'S MANUAL - BASIC SETUP DIMENSIONS & ASSEMBLY NOTES

It is critically important that you start with square and level footings or concrete pad to attach your structure.

- Pay close attention to the items needed for each step. Make sure you are using the correct hardware for each step. using incorrecdt hardware may result in improper assembly
- Remember to double check for underground utilities and overhead electrical lines

Post mounts are provided with your structure which allows you to permanently install your structure to a pre-existing or new wood concrete surface. See Anchor Instructions for further details and recommendations.

- The hardware to attach the post mounts to the structure is included.
- The hardware to mount the structure permanently to a concrete surface is included
- The hardware to mount the sctructure permanently to a wood deck is NOT included and will need to be purchased separately. You must ensure there is ample structural support under the deck before permanently attaching.

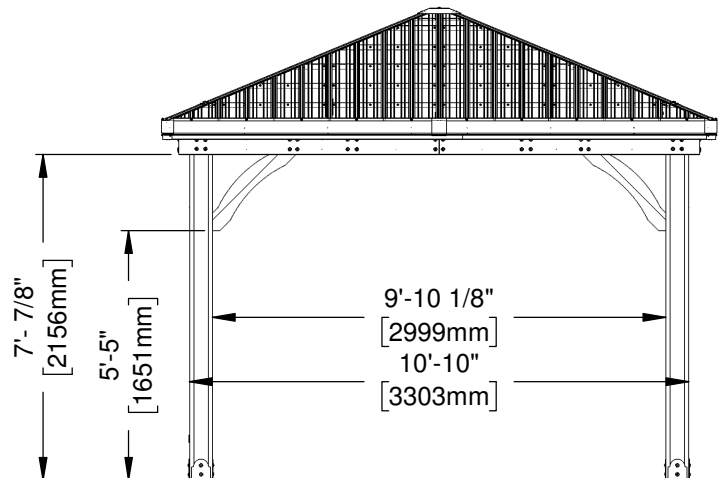
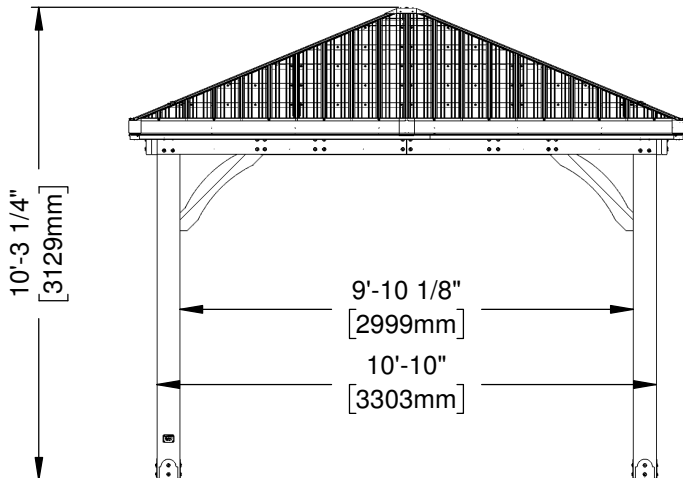
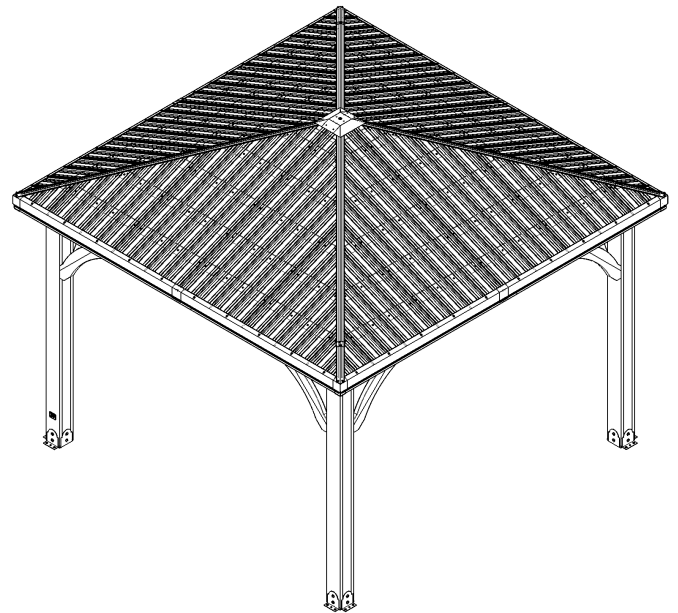
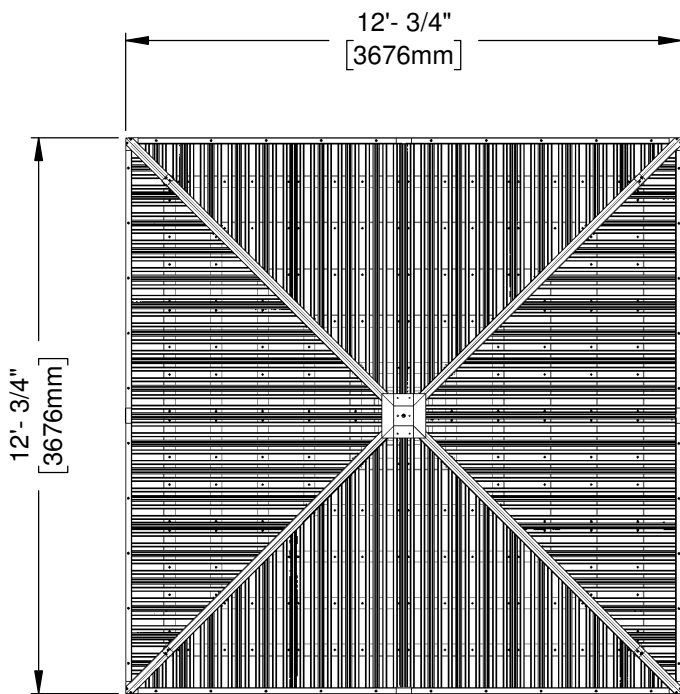

OWNER'S MANUAL - ANCHORING LAYOUT

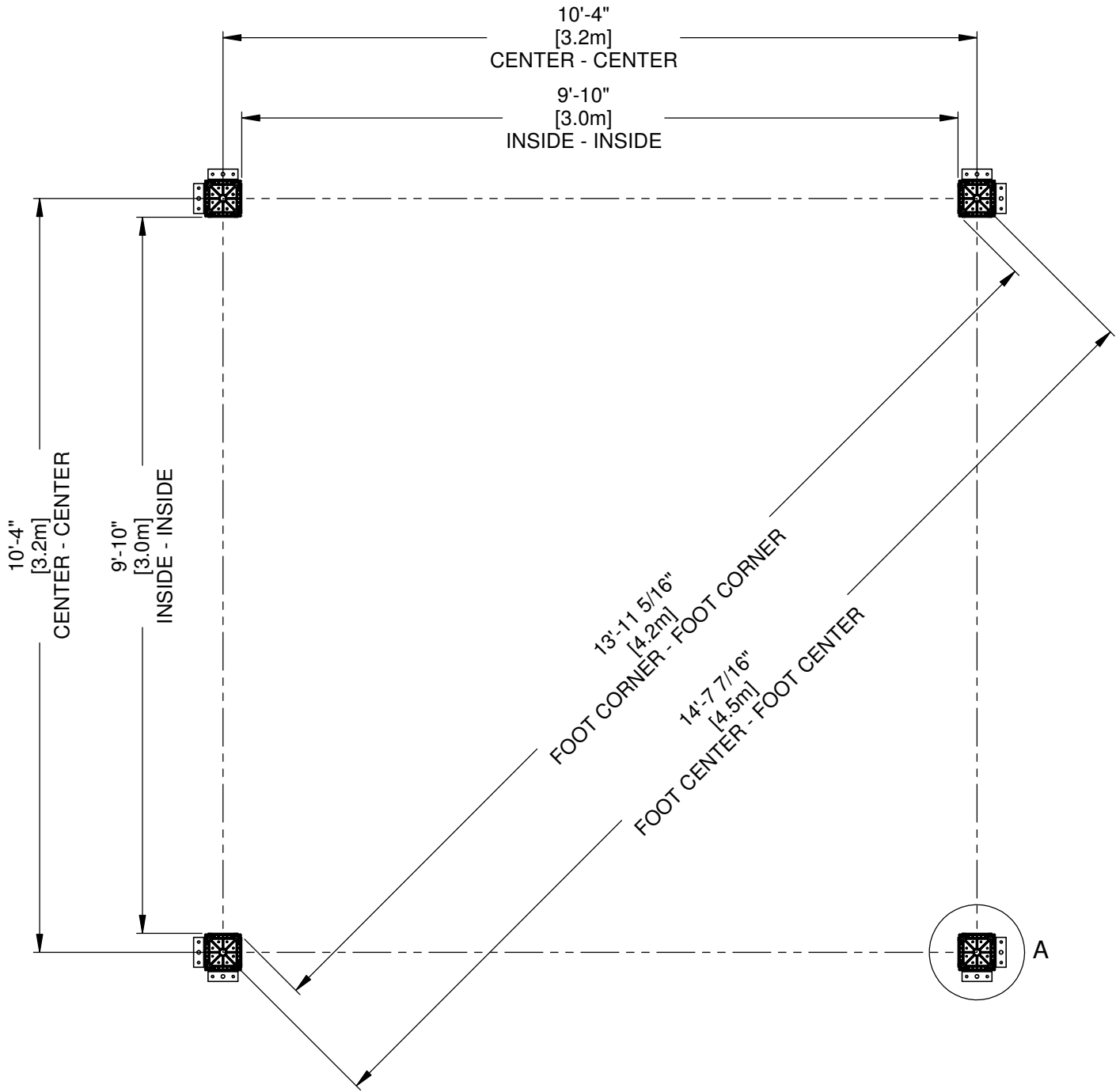

NOTE: DIMENSIONS ARE TO ANCHOR PLATES MOUNTED TO POSTS EXCEPT WHERE NOTED.

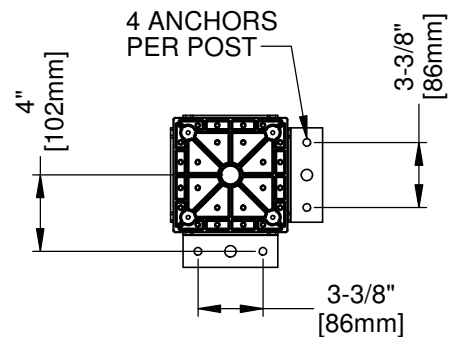

DETAIL A

OWNER'S MANUAL - PARTS IDENTIFICATION

Wood Components (Not to Scale)



C01 | CORBEL-W2A03198
(x7) | 1 7/16"x6 7/16"x35 1/8" (36x163x893)



C02 | CORBEL-W2A03198
(x1) | 1 7/16"x6 7/16"x35 1/8" (36x163x893)



D01 | BEAM-W4L20737
(x4) | 1 7/16"x5 1/4"x29 15/16" (36x134x760)



D02 | BEAM-W4L17576
(x4) | 1 7/16"x5 1/4"x1 7/16" (36x134x688)



D03 | BEAM-W4L17577
(x4) | 1 7/16"x5 1/4"x65" (36x134x1651)

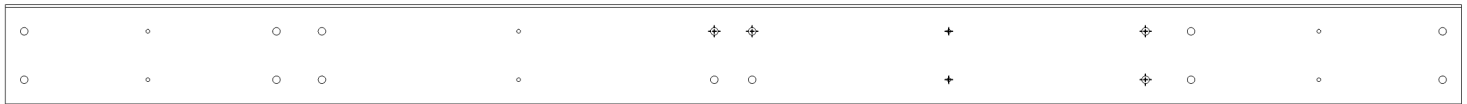

D05 | BEAM-W4L20738
(x4) | 1 7/16"x5 1/4"x75 7/8" (36x134x1927)



D06 | BEAM-W4L15241
(x4) | 1 7/16"x5 1/4"x67 13/16" (36x134x1723)



E05 | RAFTER-W4L15207
(x4) | 1 7/16"x3 3/8"x69" (36x86x1752)



E06 | RAFTER-W4L15208
(x4) | 1 7/16"x3 3/8"x45 7/16" (36x86x1155)



E07 | RAFTER-W4L15209
(x4) | 1 3/8"x3 3/8"x22" (36x86x557)



E11 | RAFTER-W4L15217
(x4) | 1 7/16"x3 3/8"x69" (36x86x1752)

OWNER'S MANUAL - PARTS IDENTIFICATION

Wood Components (Not to Scale)

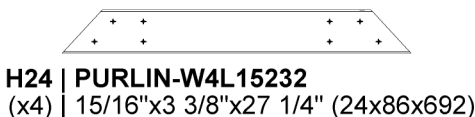
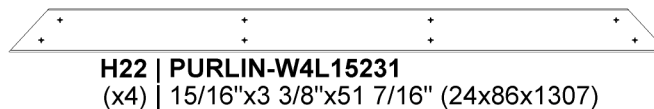
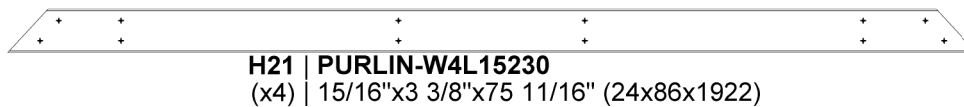
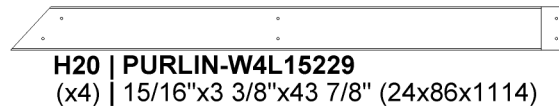
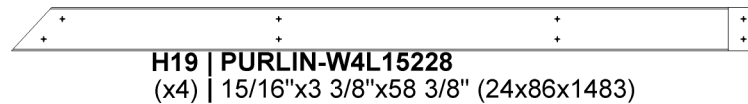
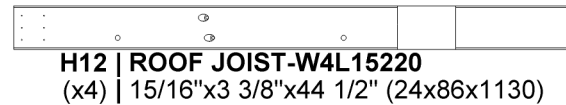
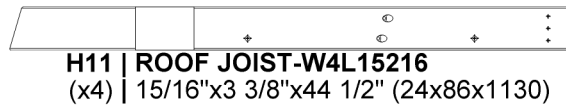
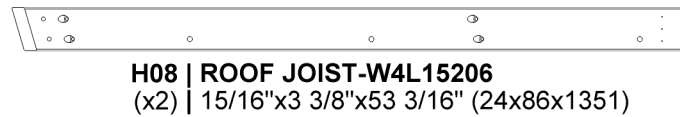
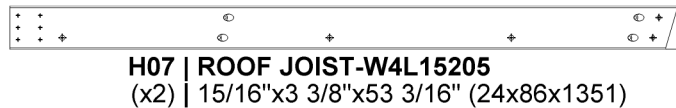
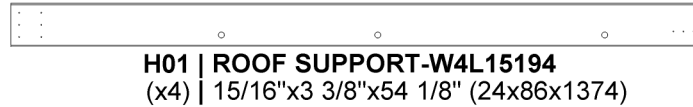
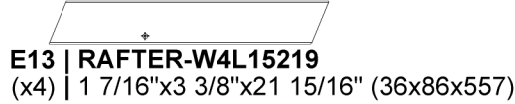
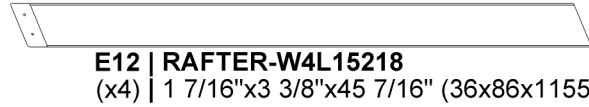

OWNER'S MANUAL - PARTS IDENTIFICATION

Wood Components (Not to Scale)



H27 | PURLIN-W4L15237
(x4) | 15/16"x3 3/8"x56" (24x86x1422)

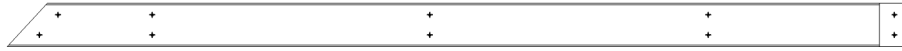

H28 | PURLIN-W4L15238
(x4) | 15/16"x3 3/8"x70 1/2" (24x86x1791)



H30 | TOP JOIST-W4L20292
(x4) | 15/16"x3 3/8"x38 13/16" (24x86x986)



H31 | SIDE PANEL ROOF JOIST-W4L20290
(x2) | 15/16"x3 3/8"x53 3/16" (24x86x1351)



H32 | SIDE PANEL ROOF JOIST-W4L20291
(x2) | 15/16"x3 3/8"x53 3/16" (24x86x1351)

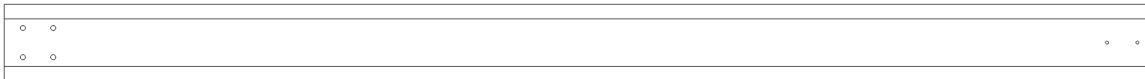

P01 | POST-W2A03202
(x2) | 6"x6"x89 1/2" (152x152x2274)

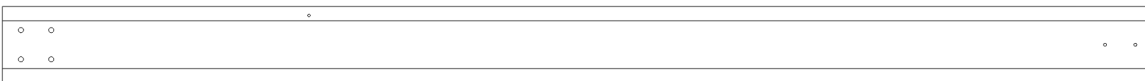

P02 | POST-W2A03203
(x2) | 6"x6"x89 1/2" (152x152x2274)



Q01 | ROOF JOIST-W4L15204
(x2) | 15/16"x4 7/16"x65 15/16" (24x112x1675)



Q02 | ROOF JOIST-W4L17579
(x2) | 15/16"x4 7/16"x64 15/16" (24x112x1649)



Q03 | ROOF JOIST-W4L15221
(x2) | 24x4 7/16"x80 1/2" (24x112x2044)



Q04 | ROOF JOIST-W4L17578
(x2) | 24x4 7/16"x79 7/16" (24x112x2018)



T02 | PURLIN-W4L15239
(x4) | 15/16"x1 5/16"x12 7/8" (24x34x327)

OWNER'S MANUAL - PARTS IDENTIFICATION

Hardware Components (Not to Scale)

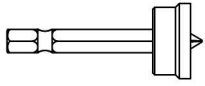

H100764 | SCREW SETTER
(x1) |

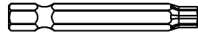

H100147 | TORX BIT
(x1) | T-30

H101058 | BOLT WH BLK
(x32) | 5/16 X 8 3/4

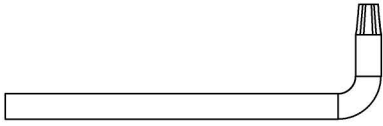
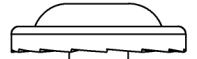

H100114 | TORX WRENCH
(x1) | T-30

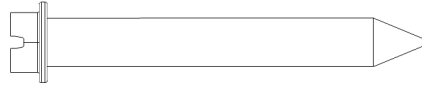

H100120 | CONCRETE ANCHOR
(x16) | 1/4"X2"

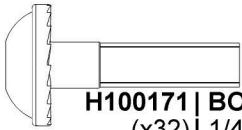

H100171 | BOLT WH BLK
(x32) | 1/4 X 1

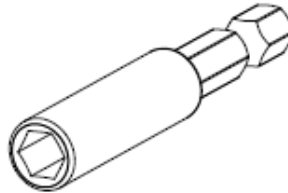

H101100 | MAGNETIC DRIVER
(x1) |



H100488 | BOLT WH
(x16) | 1/4 X 2

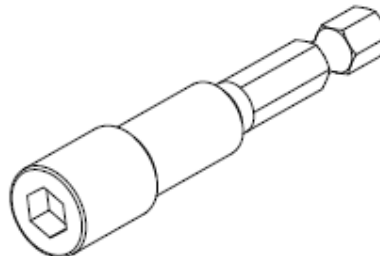

H101106 | SOCKET DRIVER
(x1) |

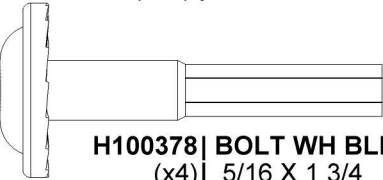

H100378 | BOLT WH BLK
(x4) | 5/16 X 1 3/4



H100195 | BOLT WH BLK
(x48) | 5/16 X 2 3/4

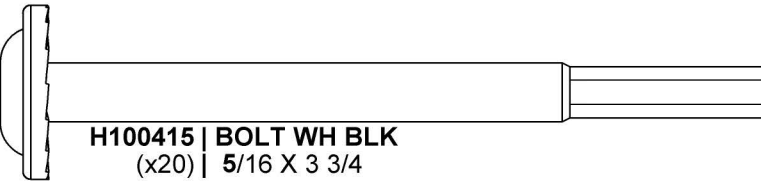

H100415 | BOLT WH BLK
(x20) | 5/16 X 3 3/4

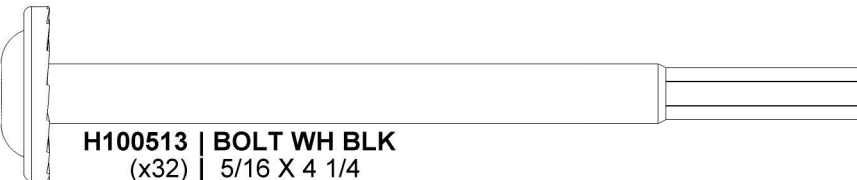

H100513 | BOLT WH BLK
(x32) | 5/16 X 4 1/4

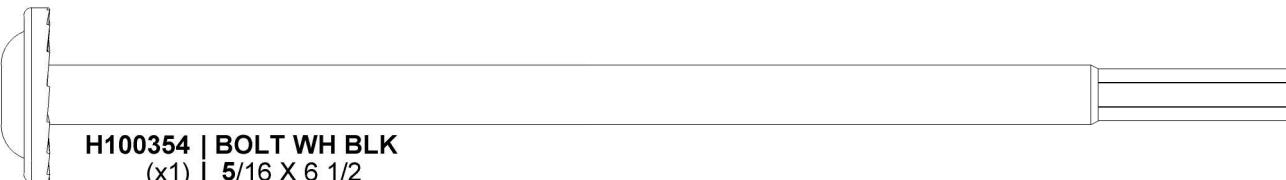

H100354 | BOLT WH BLK
(x1) | 5/16 X 6 1/2

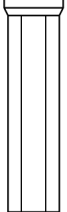

OWNER'S MANUAL - PARTS IDENTIFICATION

Hardware Components (Not to Scale)

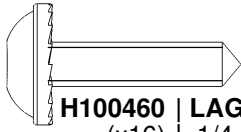

H100460 | LAG SCREW WH BLK
(x16) | 1/4 X 1

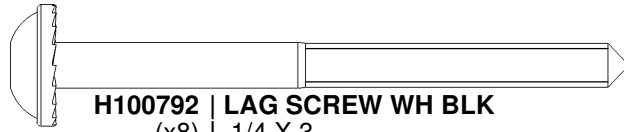

H100792 | LAG SCREW WH BLK
(x8) | 1/4 X 3

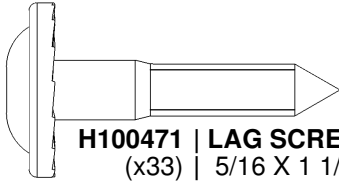

H100471 | LAG SCREW WH BLK
(x33) | 5/16 X 1 1/2

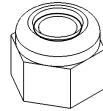

H100653 | NUT LOCK BLK
(x16) | 1/4

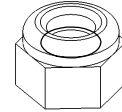

H100479 | NUT LOCK BLK
(x20) | 5/16



H101030 | CONFIRMAT SCREW
(x96) | 2

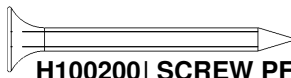

H100200 | SCREW PFH BLK
(x16) | 8 X 1 1/2

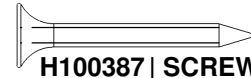

H100387 | SCREW PFH BLK
(x4) | 8 X 1 1/4

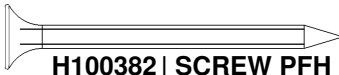

H100382 | SCREW PFH BLK
(x16) | 8 X 1 3/4

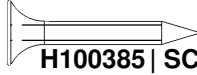

H100385 | SCREW PFH BLK
(x172) | 8 X 1

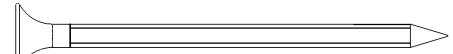

H100483 | SCREW PFH BLK
(x48) | 8 X 2 1/4



H100391 | SCREW PFH BLK
(x232) | 8 X 2

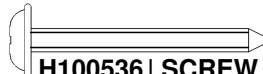

H100536 | SCREW PWH BLK
(x32) | 8 X 1 1/4

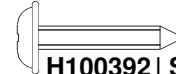

H100392 | SCREW PWH BLK
(x16) | 8 X 3/4

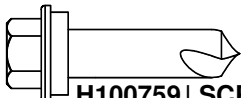

H100759 | SCREW TAPPING
(x52) | 1/4X1

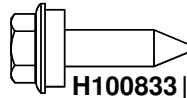

H100833 | SCREW WOODGRIP
(x224) | 10-16X3/4"

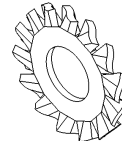

H100198 | WASHER LOCK EXT BLK
(x136) | 8X19

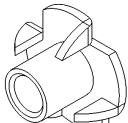

H100398 | T-NUT BLK
(x32) | 1/4X1

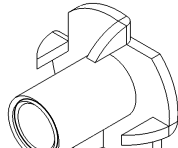

H100379 | T-NUT BLK
(x116) | 5/16



H100630 | WASHER FLAT BLK
(x32) | 8X19

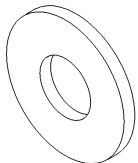

H100770 | WASHER FLAT BLK
(x20) | 9.5 X 22



H100405 | WASHER LOCK EXT BLK
(x8) | 6X15

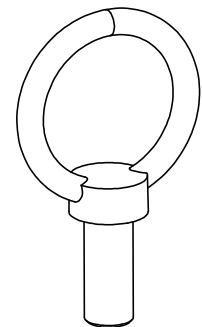

H101285 | EYE NUT
(x1) | 5/16-18 X 3/4" DIA.

OWNER'S MANUAL - PARTS IDENTIFICATION

Accessory Components (Not to Scale)

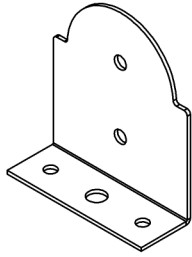

A4M01793 | POST ANCHOR PLATE
(x8)

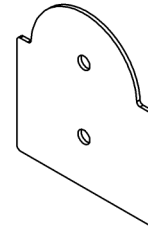

A4M01794 | POST PLATE
(x8)

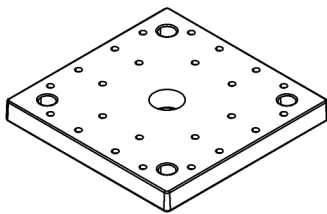

A6P00308 | 6x6 POST FOOT
(x4)

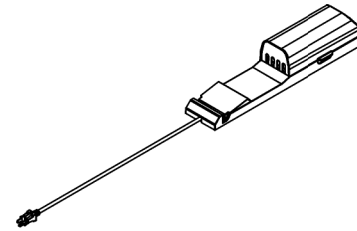

9205413 | ELECTRICAL ENCLOSURE
(x1)

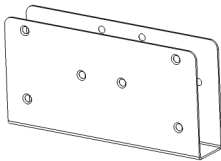

A4M01237 | ROOF SUPPORT SPLICE CLIP
(x12)

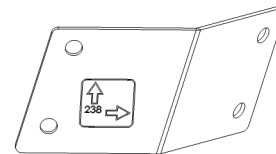

A4M01238 | PANEL BRACKET
(x4)

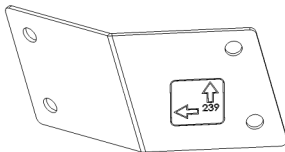

A4M01239 | PANEL BRACKET
(x4)



A4M02850 | RIDGE CAP CHANNEL SHORT
(x8)



A4M02158 | BYD ID TAG PATIO
(x1)

OWNER'S MANUAL - PARTS IDENTIFICATION

Accessory Components (Not to Scale)

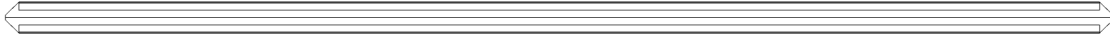

A4M02826 | CORNER RIDGE CAP LONG
(x4) |

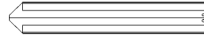

A4M02867 | CORNER RIDGE CAP SHORT
(x4) |

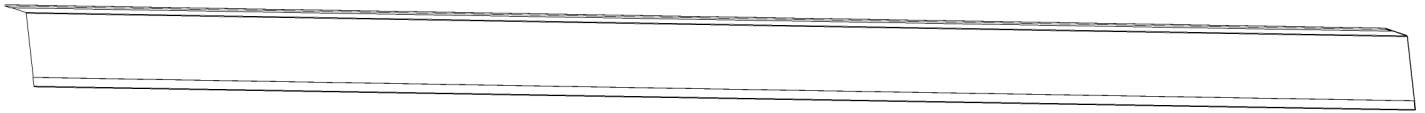

A4M02821 | EDGE TRIM
(x8) |



A4M02847 | RIDGE CAP CHANNEL LONG
(x8) |

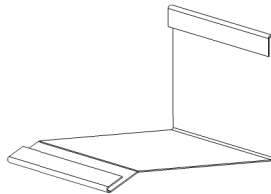

A4M03410 | DRIP EDGE SPLICE
(x4) |

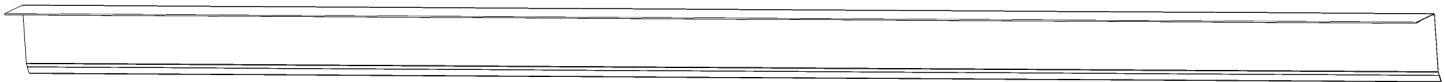

A4M03411 | DRIP EDGE
(x8) |

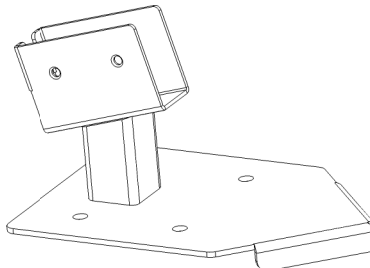

A4M01234 | POST CLIP ASSY
(x4) |

OWNER'S MANUAL - PARTS IDENTIFICATION

Accessory Components (Not to Scale)

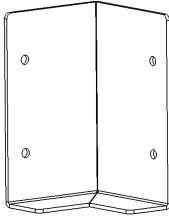

A4M01185 | CORNER BRACKET
(x4)

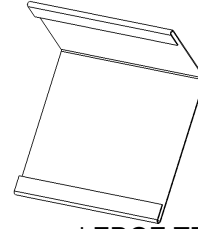

A4M02822 | EDGE TRIM SPLICE
(x4)

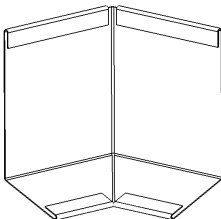

A4M02825 | EDGE TRIM CORNER SPLICE
(x4)

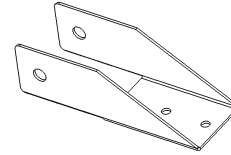

A4M01228 | RAFTER CLIP
(x16)

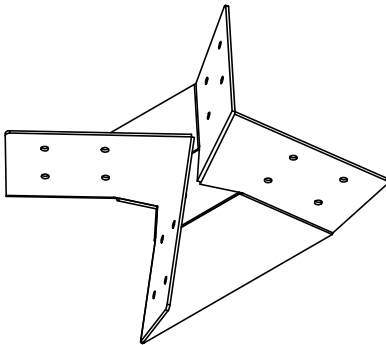

A4M01901 | PANEL SUPPORT BRACKET
(x1)

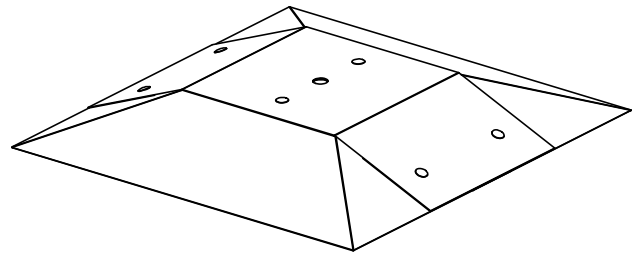

A4M01907 | PEAK RIDGE CAP
(x1)



A4M01908 | METAL SPACER
(x1)

OWNER'S MANUAL - PARTS IDENTIFICATION

Accessory Components (Not to Scale)

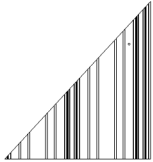

A4M01924-2 | 29GA STEEL SHEETING
(x4)

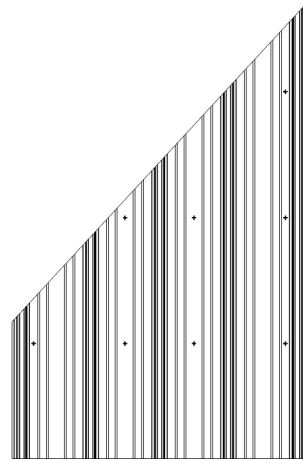

A4M01923-1 | 29GA STEEL SHEETING
(x4)

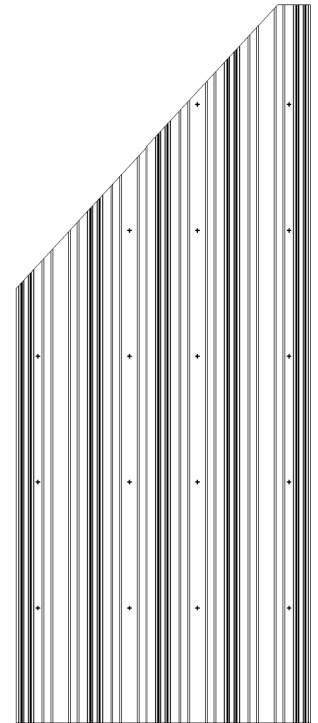

A4M01923-2 | 29GA STEEL SHEETING
(x4)

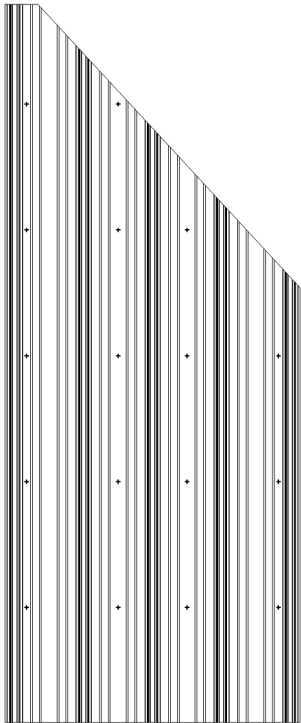

A4M01922-2 | 29GA STEEL SHEETING
(x4)

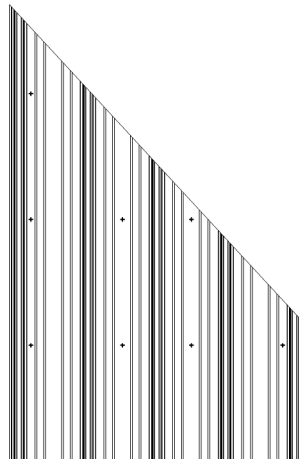

A4M01922-1 | 29GA STEEL SHEETING
(x4)

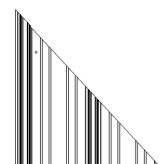

A4M01924-1 | 29GA STEEL SHEETING
(x4)

PRE-ASSEMBLY STEP 1 - SORTING PARTS

It is critical for ease of assembly that you take the time to sort and organize the wood and hardware.

WOOD PARTS:

- Organize wood parts by the three-digit, alpha-numeric number stamped on each board (ex. P01).
- If there are multiple boards with the same stamped number, stack those pieces together.
- Stamps can be found on the flat surface of the boards or on the end of the boards.
- Allow yourself plenty of room - the wood pieces can take up a significant amount of space.

NOTE: CARTONS ARE NOT ORGANIZED BY BOARD OR STEP NUMBER.



HARDWARE PARTS:

- We recommend that you have a separate table to organize the hardware.
- Hardware bags are printed with a seven-digit, alpha-numeric part number.
- You can organize your hardware by part number or group by hardware type (e.g. bolts, nuts, etc.).
- During assembly you only need to reference the last four digits of the number.

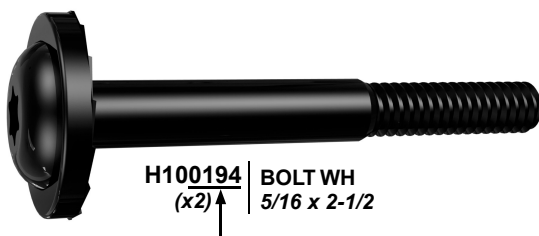

PRE-ASSEMBLY STEP 2 - TOOLS REQUIRED



Cordless Drill or Electric Drill



Drill Attachments:
Phillips Head

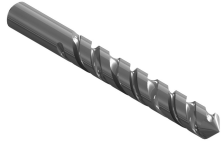

1/8" & 3/8" Drill Bits



Phillips Screw Driver

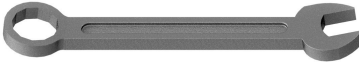

Open End Wrenches 1/2" & 7/16"



3/8" Drive Ratchet, 1/2" & 7/16" STD Sockets, 1/2" & 7/16" Deep Sockets



Tape Measure



Claw Hammer

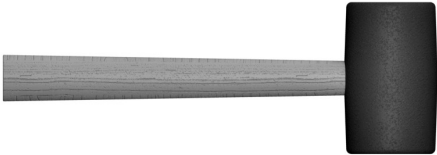

Rubber Mallet - Optional

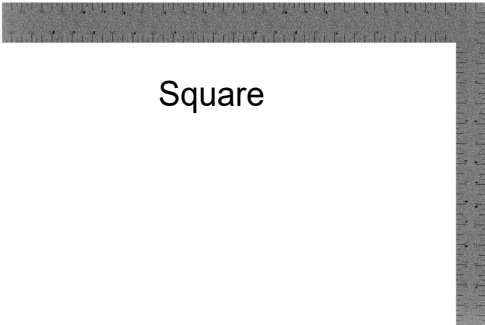

Square



Level 24"

PRE-ASSEMBLY STEP 3 - CHOOSE YOUR ASSEMBLY METHOD

There are several types of assembly instructions available to you.

1. Printed Assembly Manual included with your set
2. BILT APP - 3D interactive instructions
3. Combination of the Printed Manual and BILT APP (Note: Step numbers can differ between the two methods)



STEP 1 - POST ASSEMBLY

QTY	PART NUMBER	DESCRIPTION
8	H100200	SCREW PFH 8x1 1/2 BLK



P01 POST - W2A03202-1
(x1) 1 1/4"x6"x89 1/2" (152x152x2274)



P02 POST - W2A03202-1
(x1) 1 1/4"x6"x89 1/2" (152x152x2274)

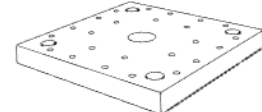

A6P00308 - 6x6 POST FOOT
(x2)

- FOR EASE OF ASSEMBLY, SAW HORSES ARE RECOMMENDED FOR POST AND BEAM ASSEMBLIES
- ALIGN FEET WITH POSTS AND PRE-DRILL HOLES WITH 1/8" DRILL BIT PRIOR TO ATTACHMENT

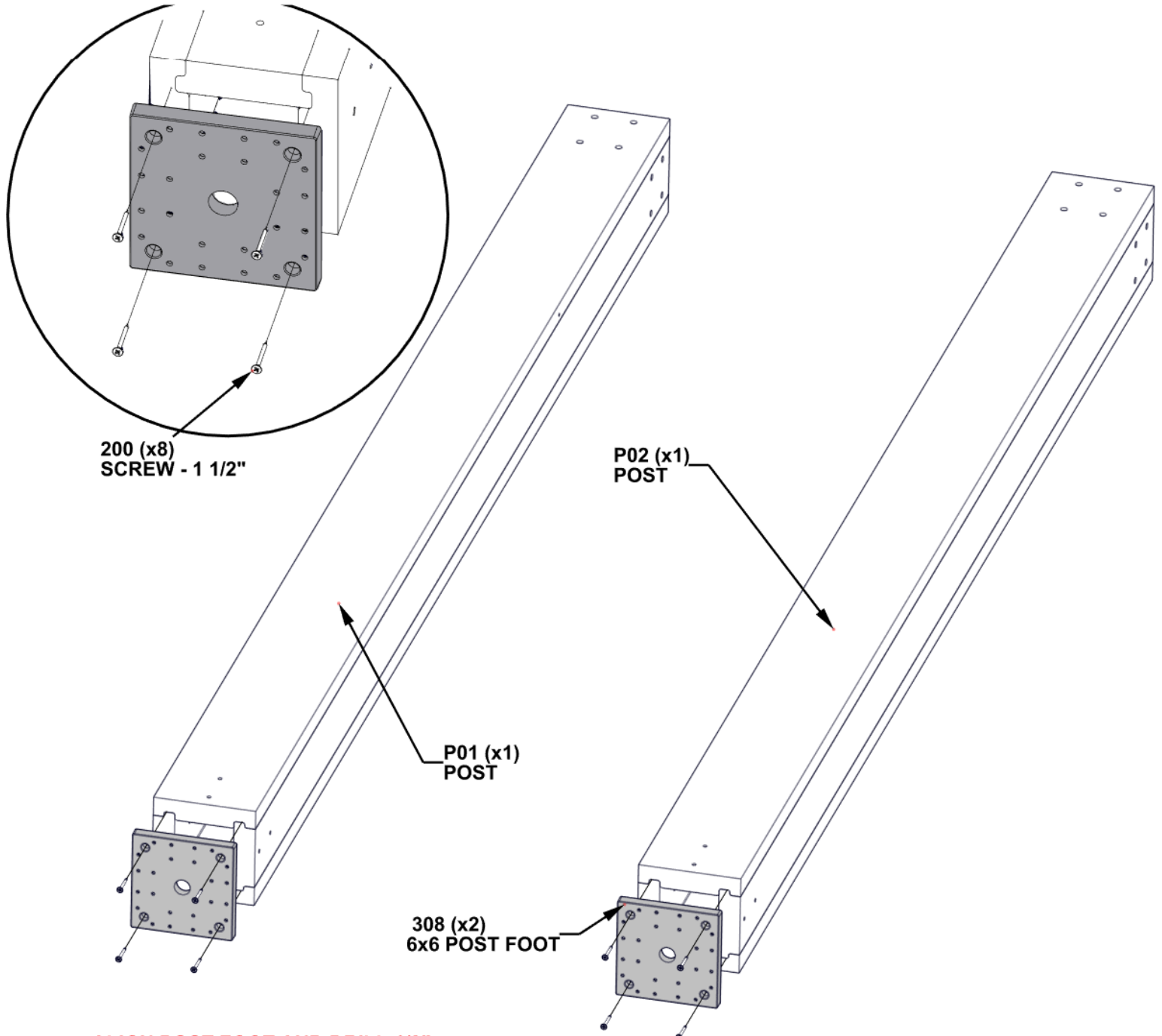

**ALIGN POST FOOT AND DRILL 1/8"
[3mm] PILOT HOLES FOR THE
ATTACHMENT HARDWARE.**

STEP 2 - 130" BEAM ASSEMBLY



D05 BEAM - W4L20738
(x1) 1 7/16"x5 1/4"x75 7/8" (36x134x1927)



D03 BEAM - W4L17577
(x2) 1 7/16"x5 1/4"x65" (36x134x1651)

QTY	PART NUMBER	DESCRIPTION
12	H100195	BOLT WH 5/16x2 3/4 BLK
12	H100198	WASHER LOCK EXT 8x19
12	H100379	TNUT-5/16" BLK

- INSERT T-NUTS FIRST

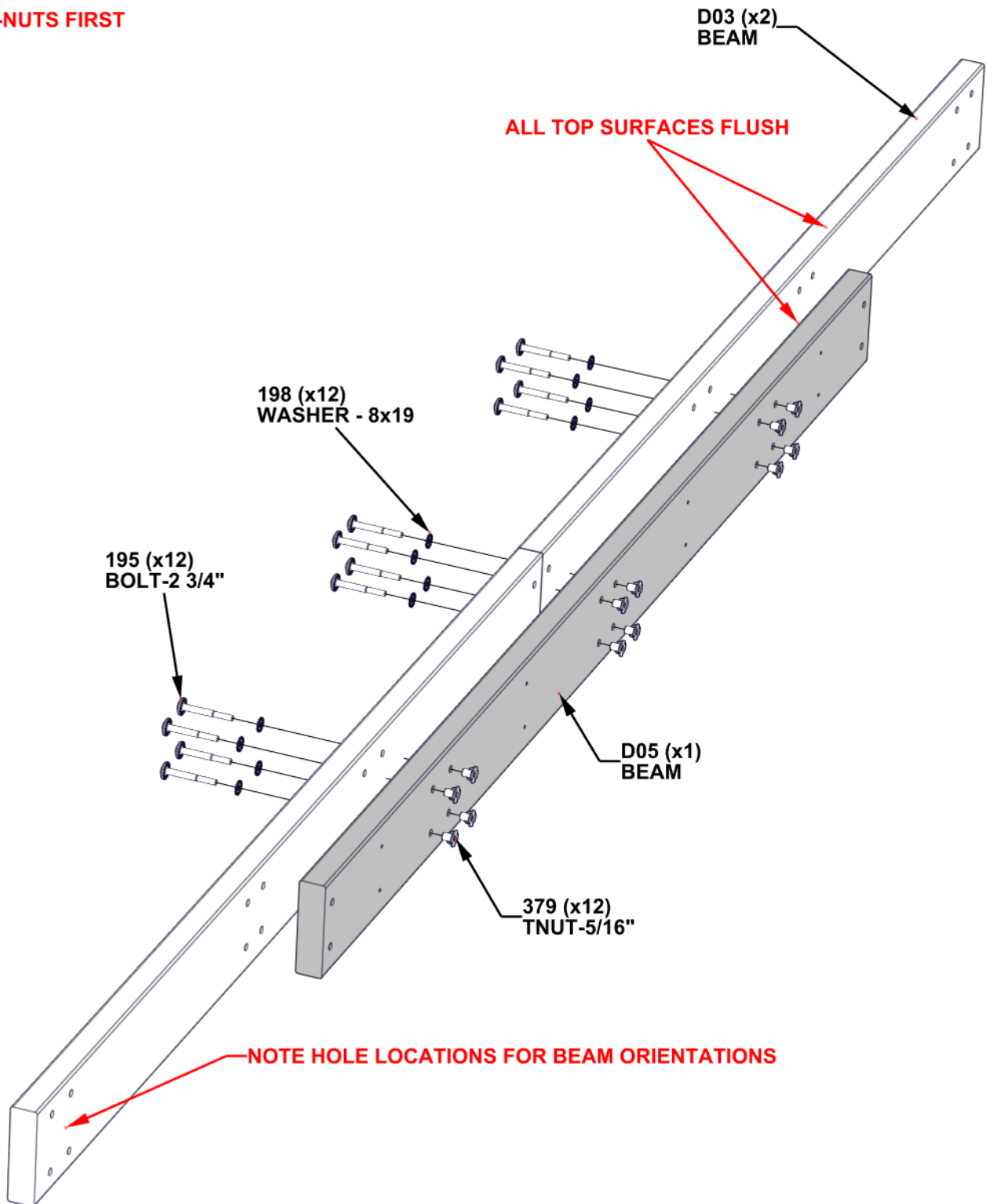

STEP 3 - 130" BEAM ASSEMBLY



D02 BEAM - W4L17576
 (x2) 27 1/16"x5 1/4"x1 7/16" (688x134x36)

QTY	PART NUMBER	DESCRIPTION
12	H100483	SCREW PFH 8x2 1/4 BLK

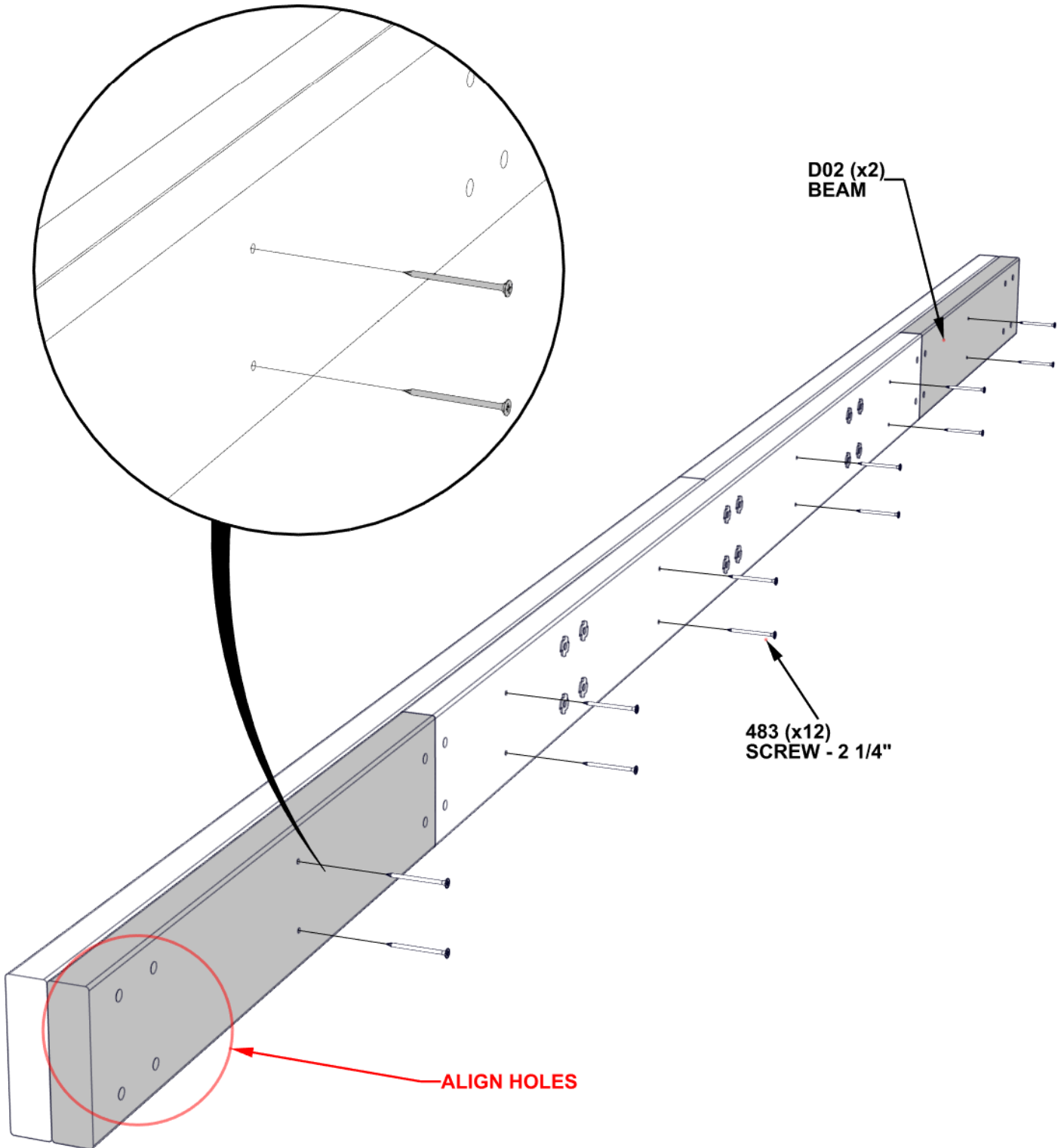

STEP 4 - 130" BEAM & POST ASSEMBLY

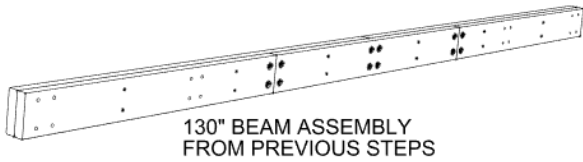

QTY	PART NUMBER	DESCRIPTION
8	H100198	WASHER LOCK EXT 8x19
8	H100379	TNUT-5/16" BLK
8	H101058	BOLT WH 5/16x8 3/4 BLK

- INSERT T-NUTS FIRST

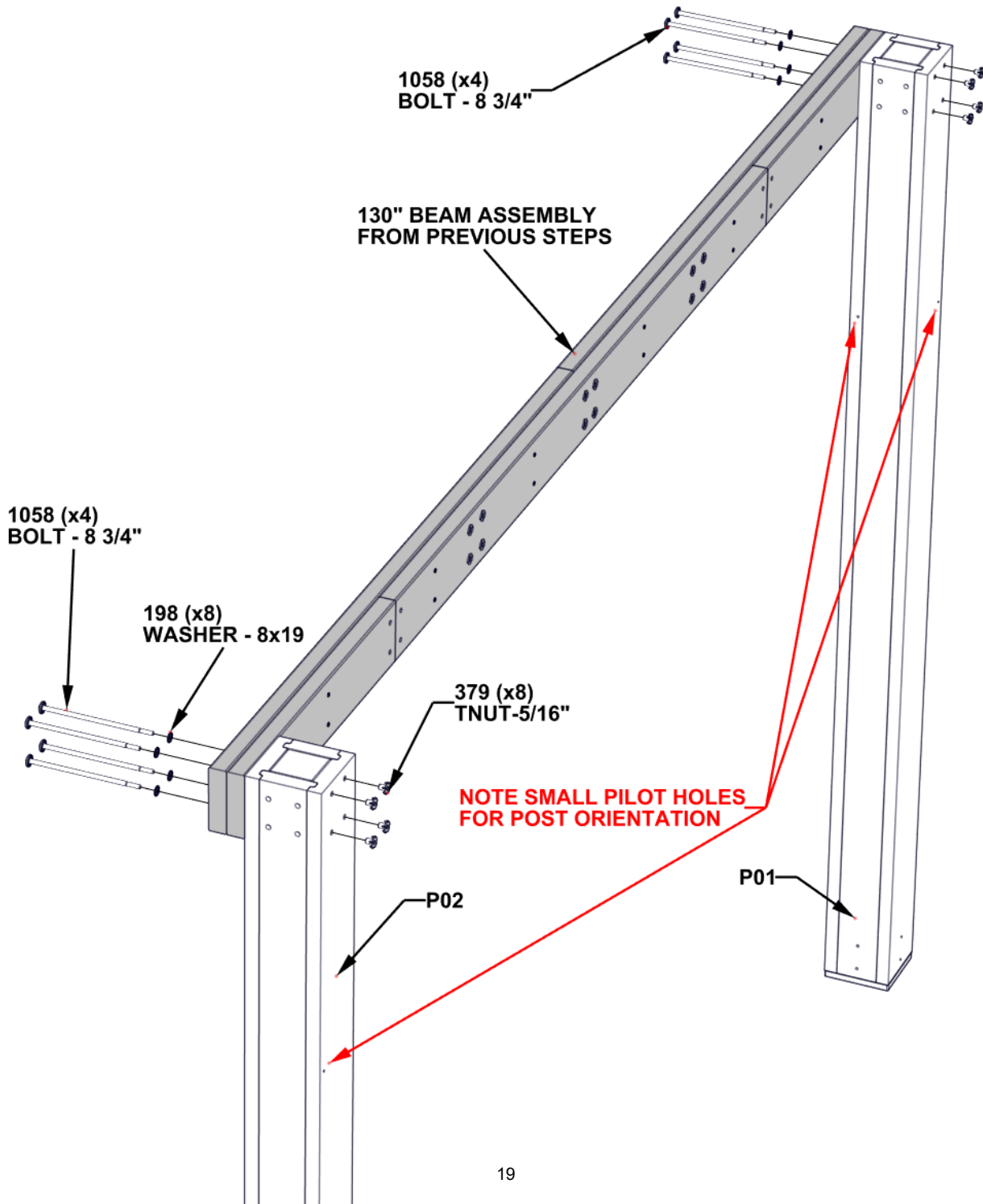

STEP 5 - 130" BEAM & POST ASSEMBLY



C01 CORBEL - W2A03198-1
(x2) 1 7/16"x3 3/8"x35 1/8" (36x86x893)

QTY	PART NUMBER	DESCRIPTION
8	H100198	WASHER LOCK EXT 8x19
8	H100379	TNUT-5/16" BLK
2	H100405	WASHER LOCK EXT 6x15
8	H100513	BOLT WH 5/16x4 1/4 BLK
2	H100792	LAG SCREW WH 1/4x3 BLK

- INSERT T-NUTS FIRST

- INSERT BOLTS BEFORE LAG SCREWS

-TO AVOID SPLITTING, MAKE SURE LAG SCREWS GO INTO PILOT HOLES

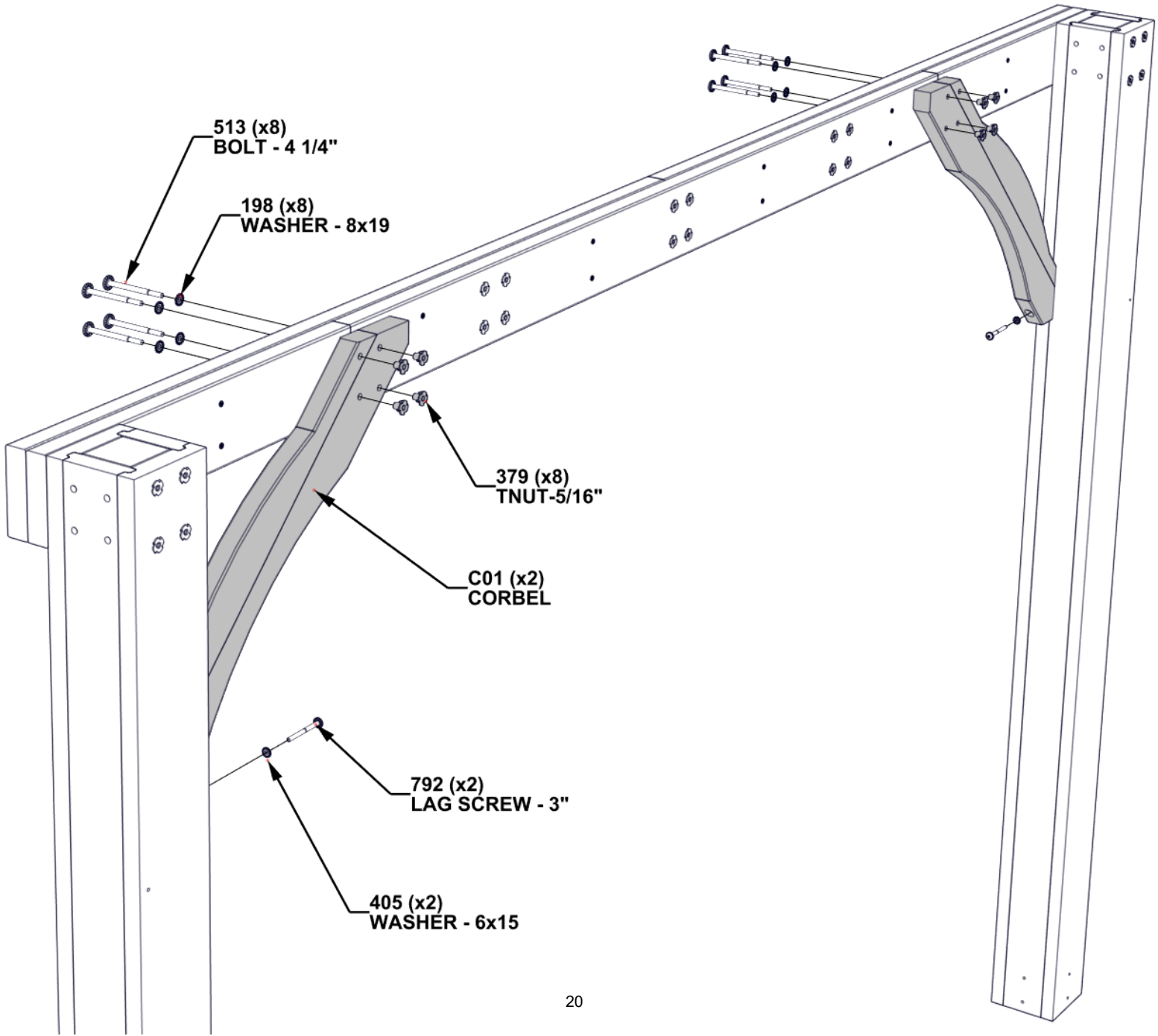

**REPEAT 130" BEAM & POST
ASSEMBLY STEPS 1 THROUGH 5**

STEP 6 - 135-3/4" BEAM ASSEMBLY



D06 BEAM - W4L15241
 (x2) 1 7/16"x5 1/4"x67 13/16" (36x134x1723)



D05 BEAM - W4L20738
 (x1) 1 7/16"x5 1/4"x75 7/8" (36x134x1927)

QTY	PART NUMBER	DESCRIPTION
12	H100195	BOLT WH 5/16x2 3/4 BLK
12	H100198	WASHER LOCK EXT 8x19
12	H100379	TNUT-5/16" BLK

- INSERT T-NUTS FIRST

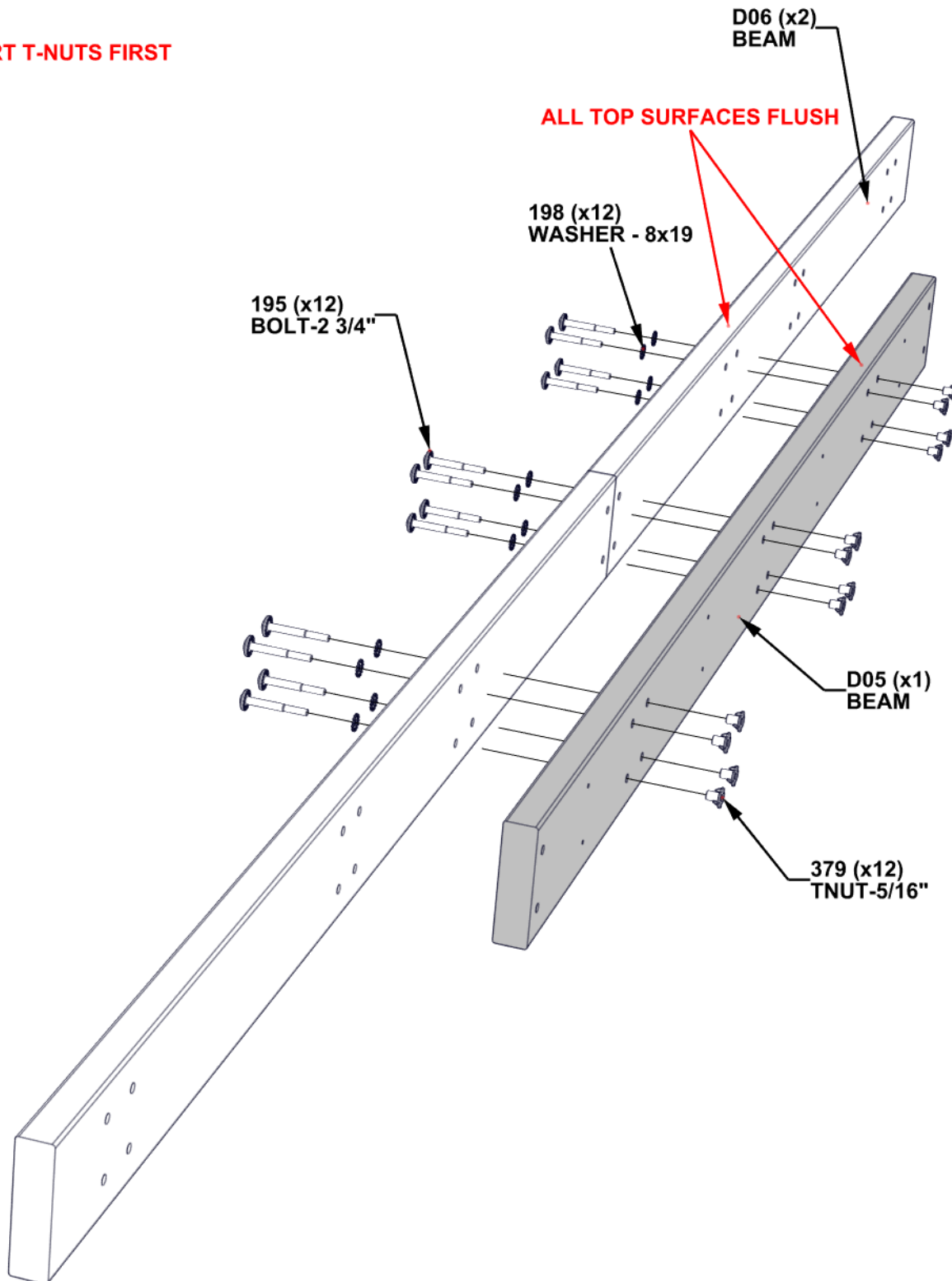

STEP 7 - 135-3/4" BEAM ASSEMBLY

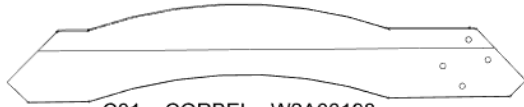

C01 CORBEL - W2A03198
(x1) 1 7/16"x6 7/16"x35 1/8" (36x163x893)

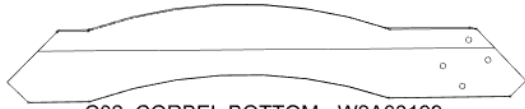

C02 CORBEL BOTTOM - W2A03199
(x1) 1 7/16"x6 7/16"x35 1/8" (36x163x893)

QTY	PART NUMBER	DESCRIPTION
8	H100198	WASHER LOCK EXT 8x19
8	H100379	TNUT-5/16" BLK
8	H100513	BOLT WH 5/16x4 1/4 BLK



D01 BEAM - W4L20737
(x2) 1 7/16"x5 1/4"x29 15/16" (36x134x760)

- INSERT T-NUTS FIRST

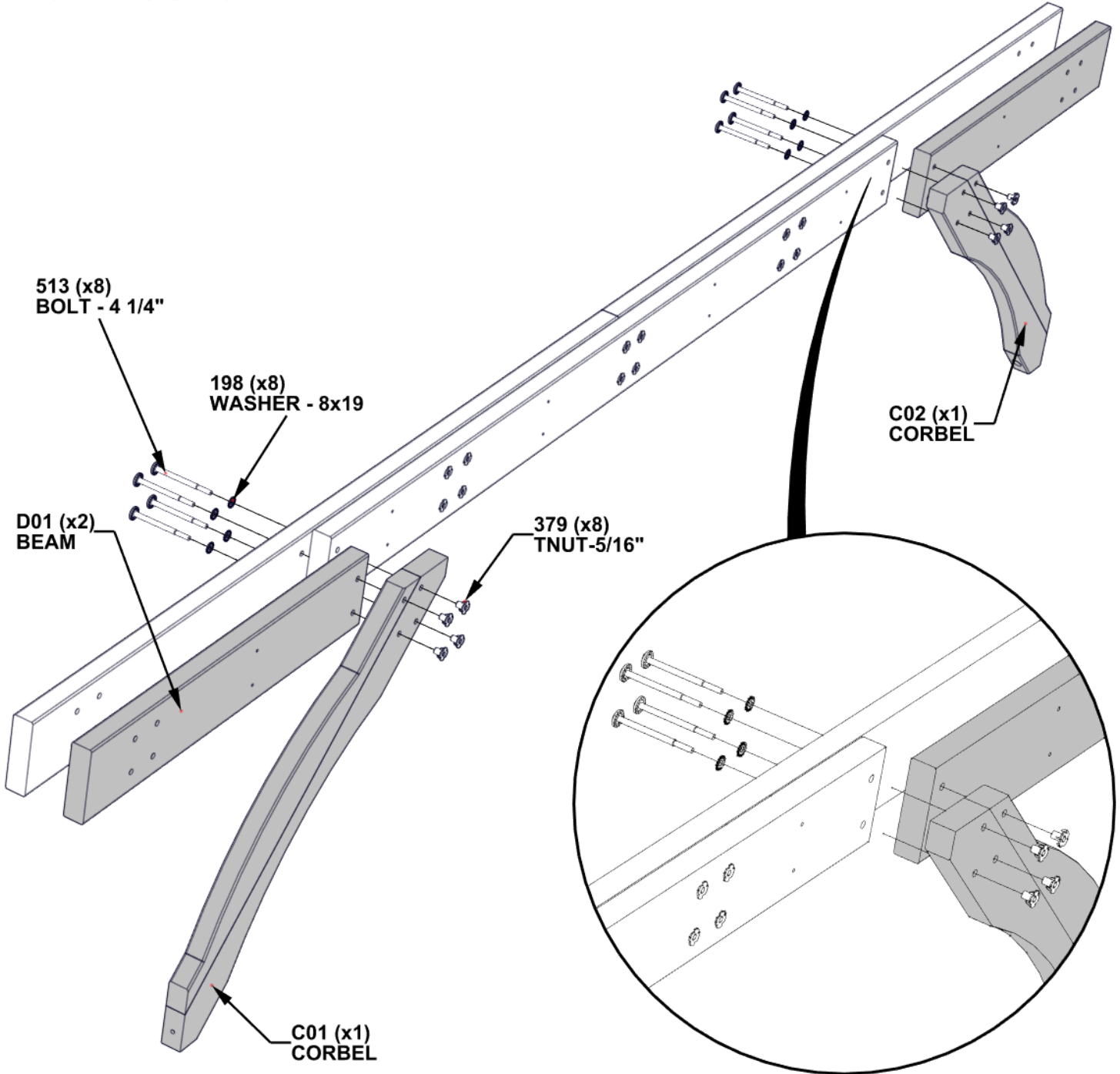

STEP 8 - 135-3/4" BEAM ASSEMBLY

QTY	PART NUMBER	DESCRIPTION
12	H100483	SCREW PFH 8x2 1/4 BLK

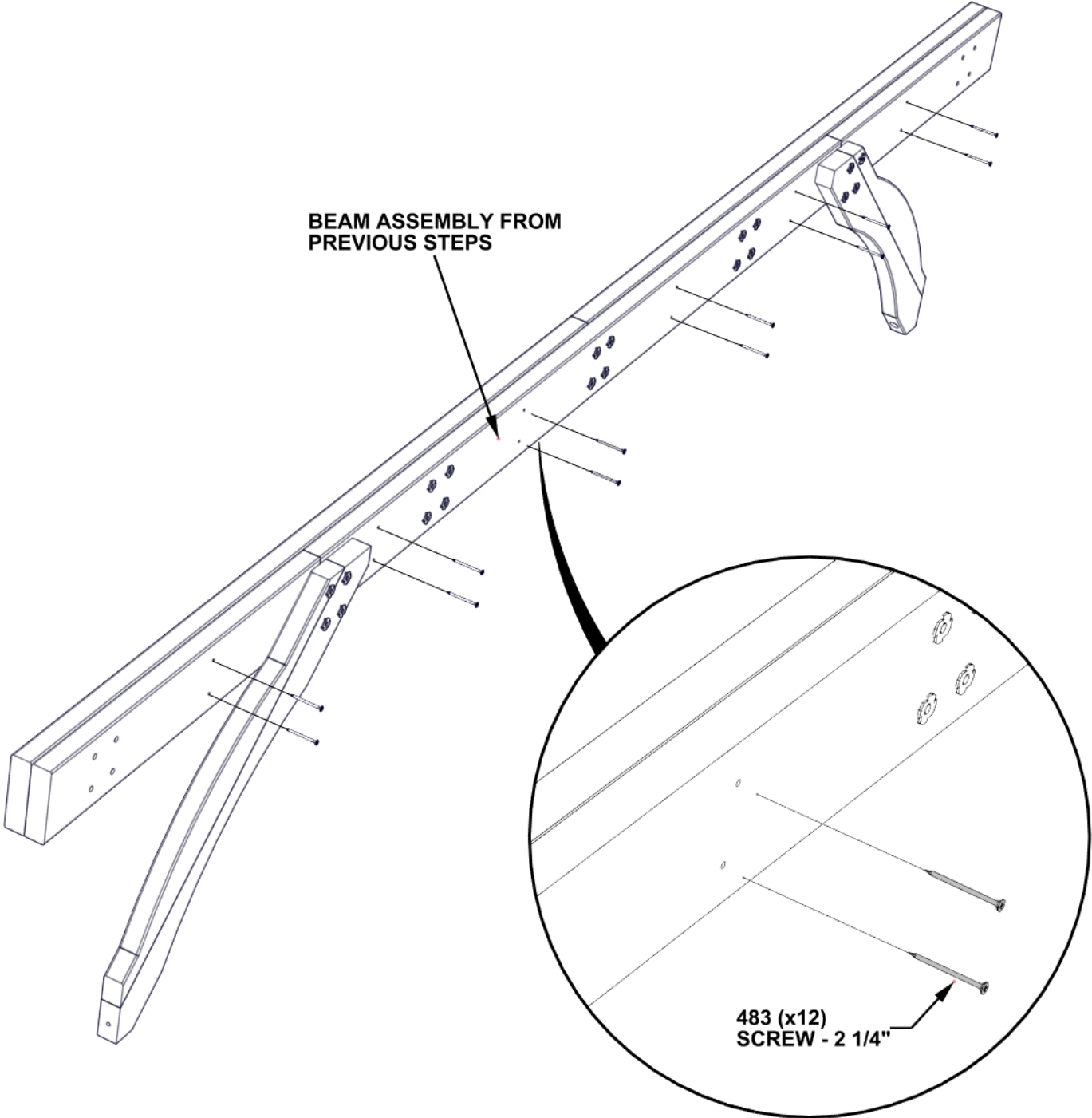

**REPEAT 135-3/4" BEAM
ASSEMBLY STEPS 6 THROUGH 8**

STEP 9 - STRUCTURE ASSEMBLY

QTY	PART NUMBER	DESCRIPTION
8	H100198	WASHER LOCK EXT 8x19
8	H100379	TNUT-5/16" BLK
2	H100405	WASHER LOCK EXT 6x15
2	H100792	LAG SCREW WH 1/4x3 BLK
8	H101058	BOLT WH 5/16x8 3/4 BLK

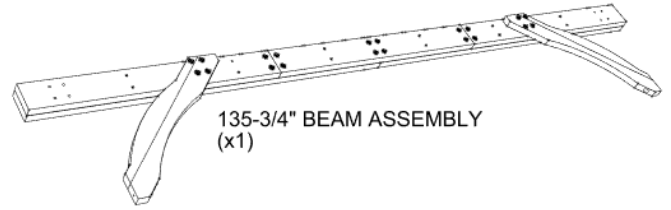
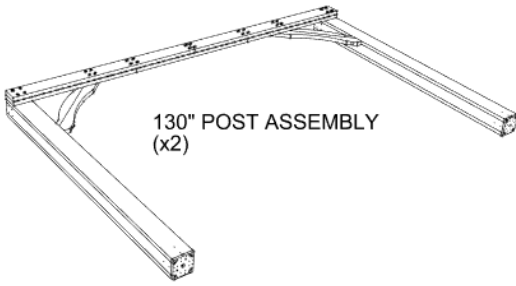

- INSERT T-NUTS FIRST

- 3 PEOPLE ARE HELPFUL FOR THIS STEP.

- MOVE THE POST ASSEMBLIES TO THEIR FINAL LOCATION WITH SOMEONE HOLDING EACH ASSEMBLY UPRIGHT.

- USING A THIRD PERSON, CONNECT THE 135-3/4" BEAM ASSEMBLY TO THE POSTS TO MAKE THE GAZEBO FRAME.

- HAND TIGHTEN ONLY

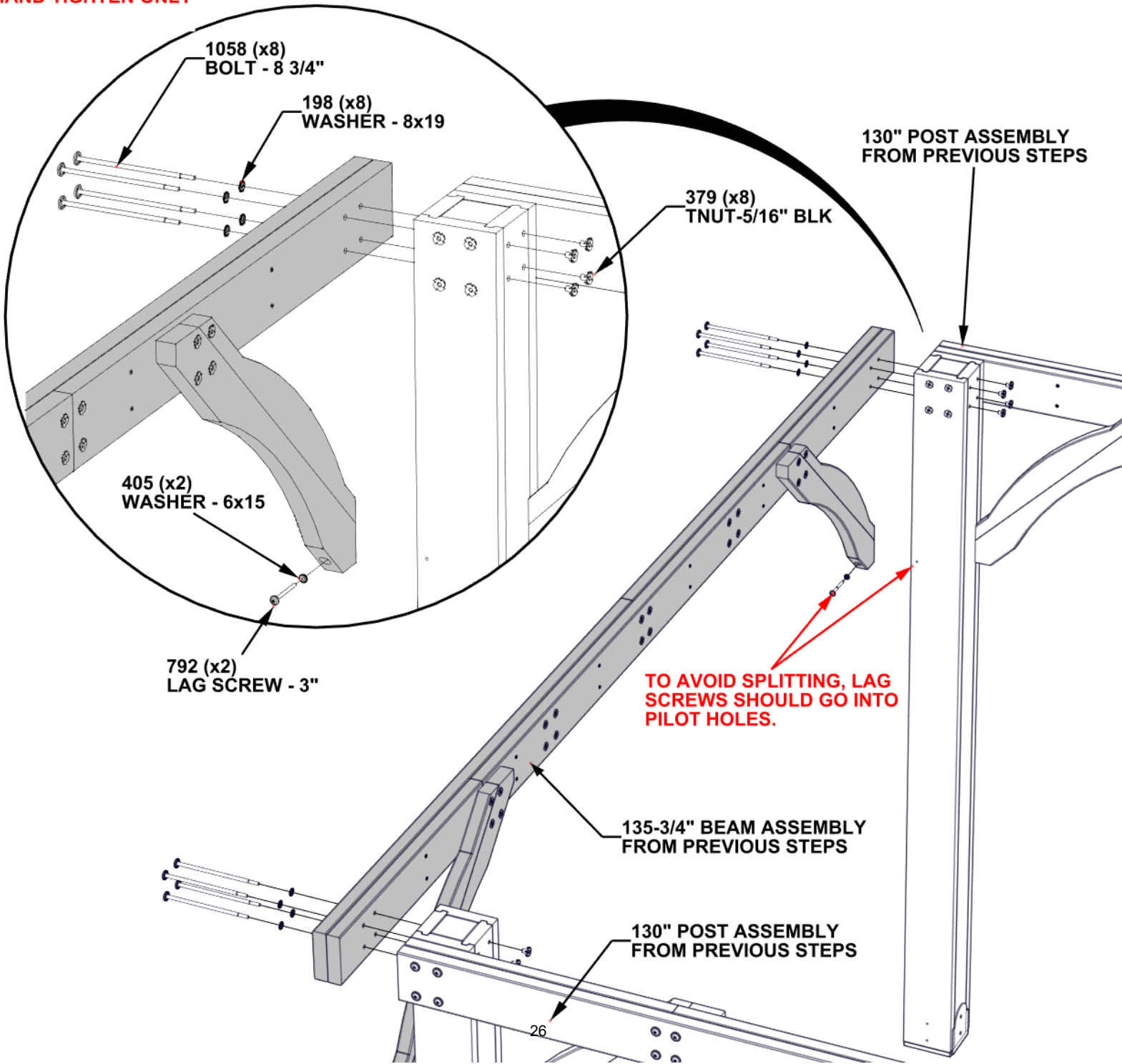

**REPEAT 135-3/4" BEAM TO POST
ASSEMBLY STEP 9**

STEP 10 - SQUARE STRUCTURE

**CRITICAL: SQUARE UNIT BEFORE PROCEEDING TO NEXT STEPS.
ONCE SQUARE, TIGHTEN ALL HARDWARE.**

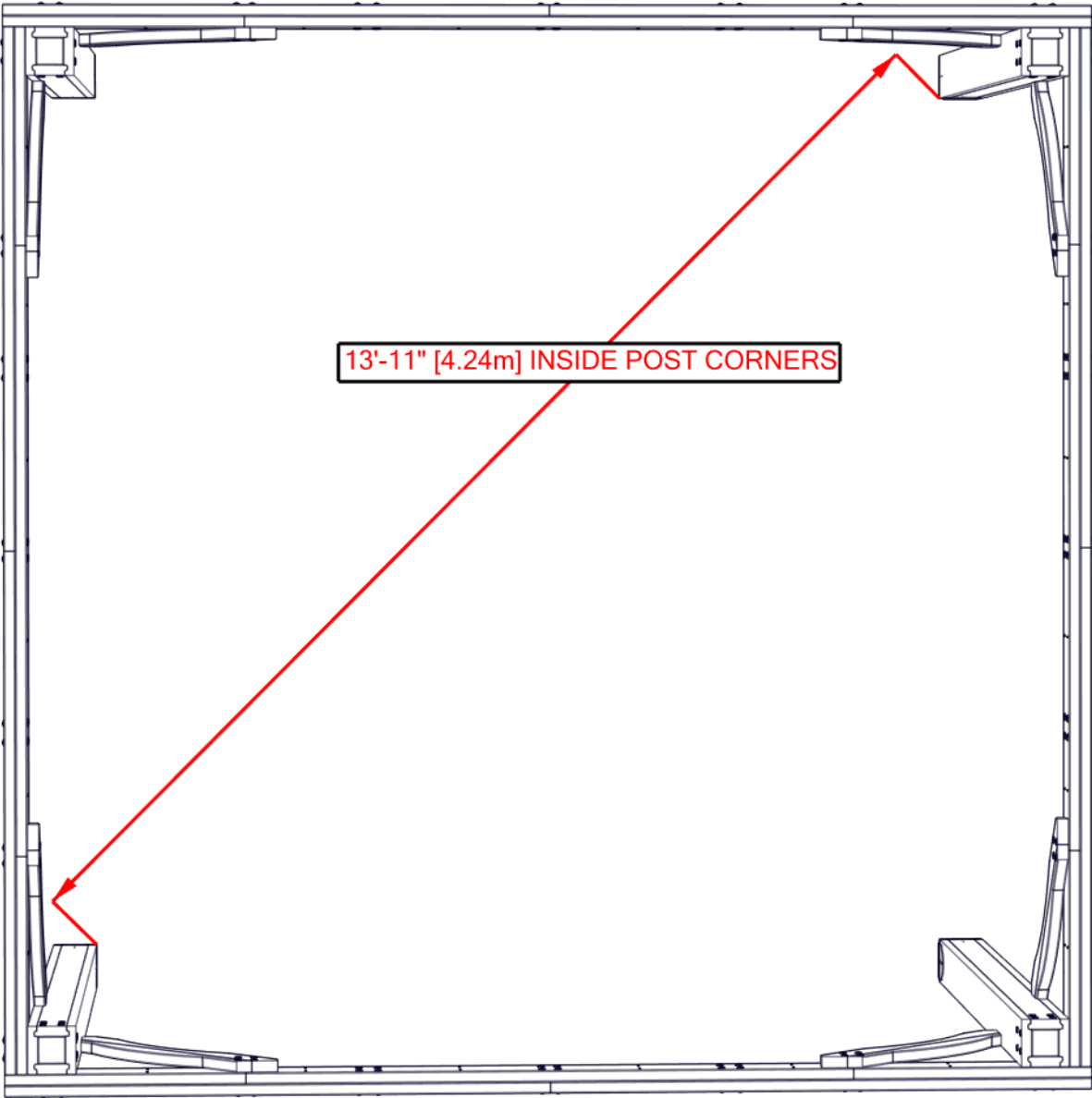

STEP 11 - ROOF SUPPORT ASSEMBLY

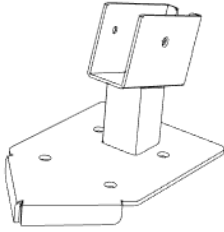

A4M01234 - 1234 POST CLIP ASSY
(x4)

QTY	PART NUMBER	DESCRIPTION
16	H100460	LAG SCREW WH 1/4x1 BLK

- REPEAT ON ALL 4 POSTS
- DO NOT OVERTIGHTEN

460 (x4)
LAG SCREW - 1"

1234 (x1)
POST CLIP ASSY

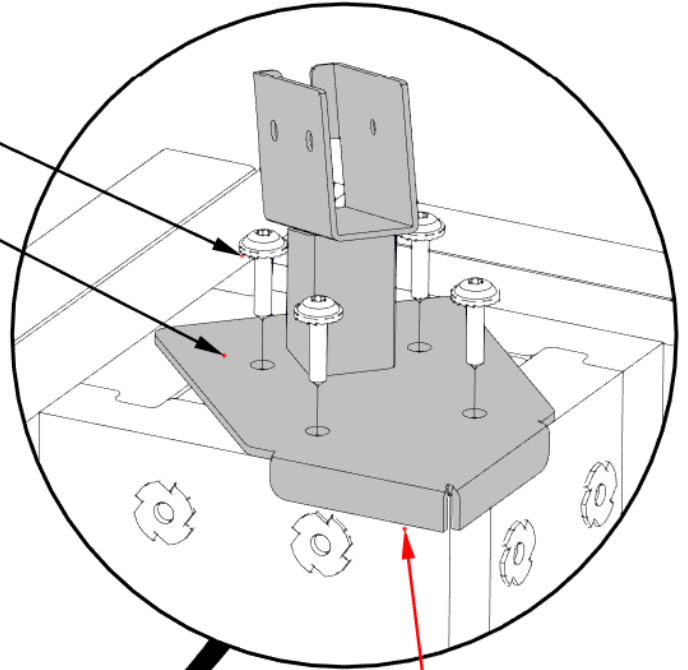

**POST CLIPS MUST BE
FLUSH TO POST BEFORE
ATTACHING SCREWS**

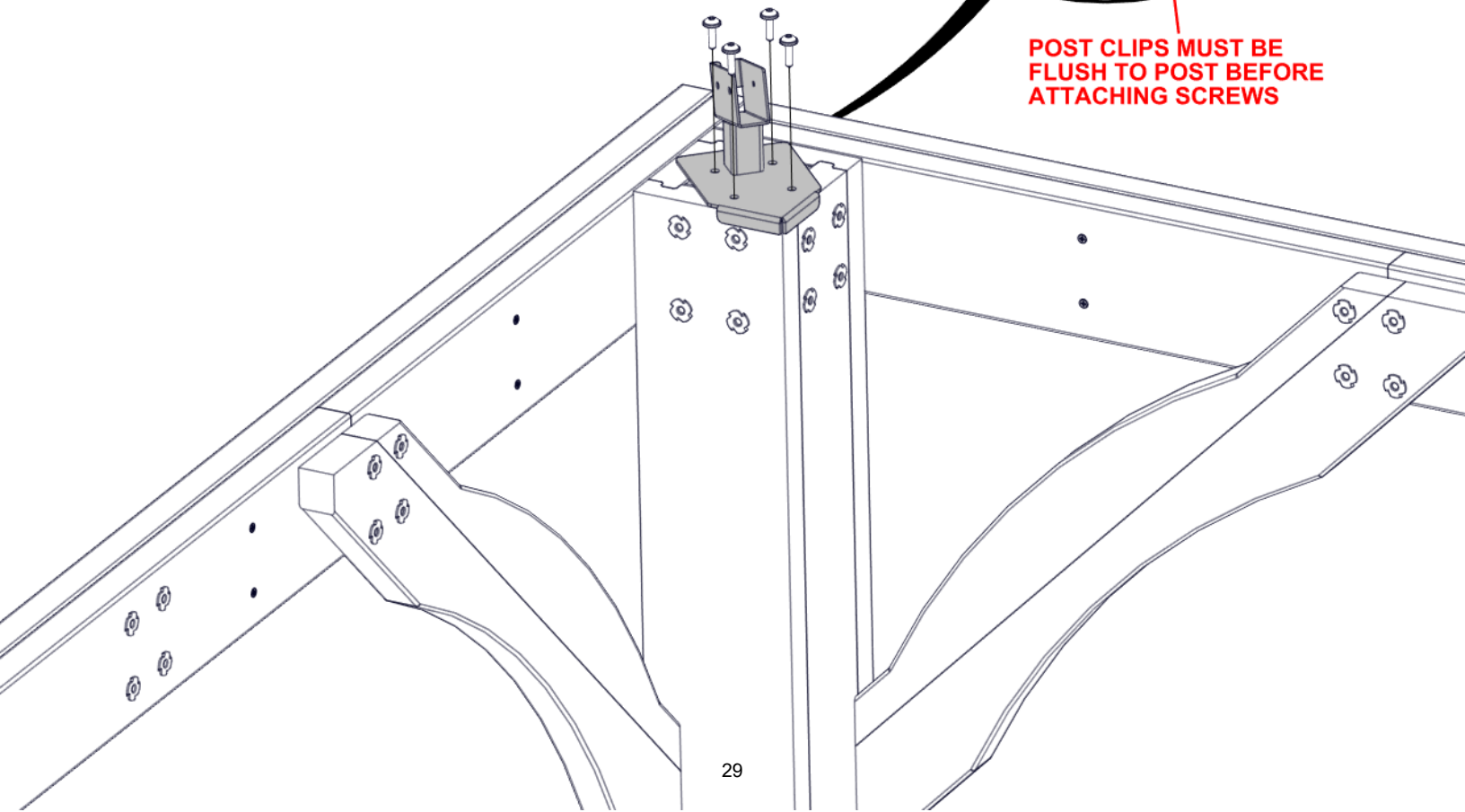

STEP 12 - ROOF SUPPORT ASSEMBLY

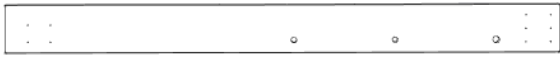

H30 TOP JOIST - W4L20292
(x4) 15/16"x3 3/8"x38 13/16" (24x86x986)

QTY	PART NUMBER	DESCRIPTION
48	H100385	SCREW PFH 8x1 BLK

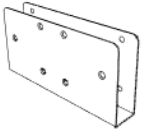

A4M01237 - ROOF SUPPORT SPLICE CLIP
(x4)



H01 ROOF SUPPORT - W4L15194
(x4) 15/16"x3 3/8"x54 1/8" (24x86x1374)

- USE PILOT HOLES TO ATTACH SPLICE CLIP TO H01 & H30

- REPEAT THIS STEP 3 MORE TIMES

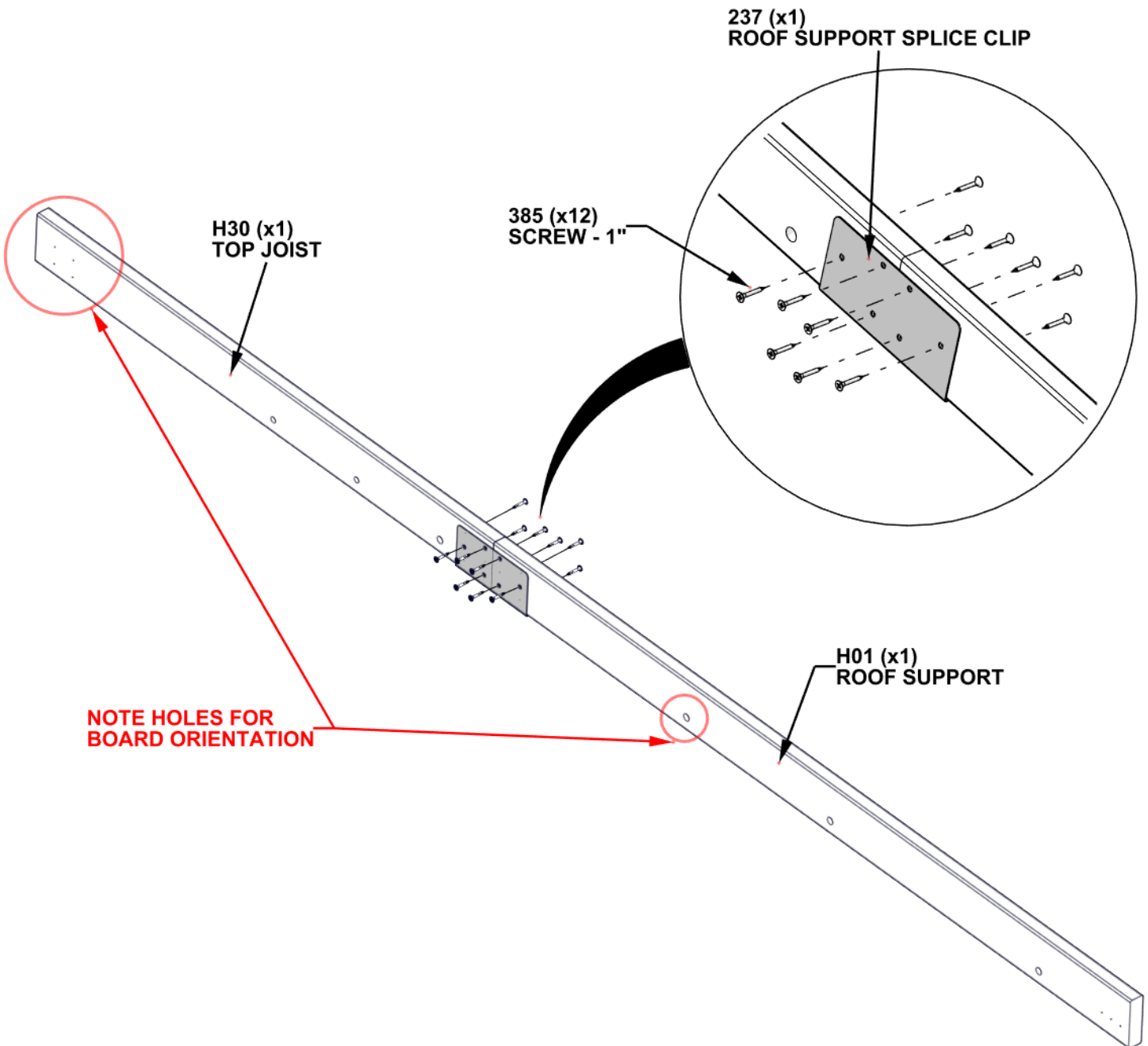

STEP 13 - ROOF SUPPORT ASSEMBLY

QTY	PART NUMBER	DESCRIPTION
16	H100385	SCREW PFH 8 X 1 BLK

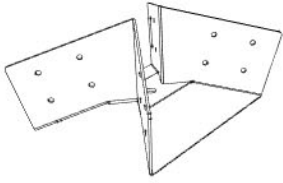

A4M01901 BROKE PLATE
(x1)

- REPEAT THIS STEP

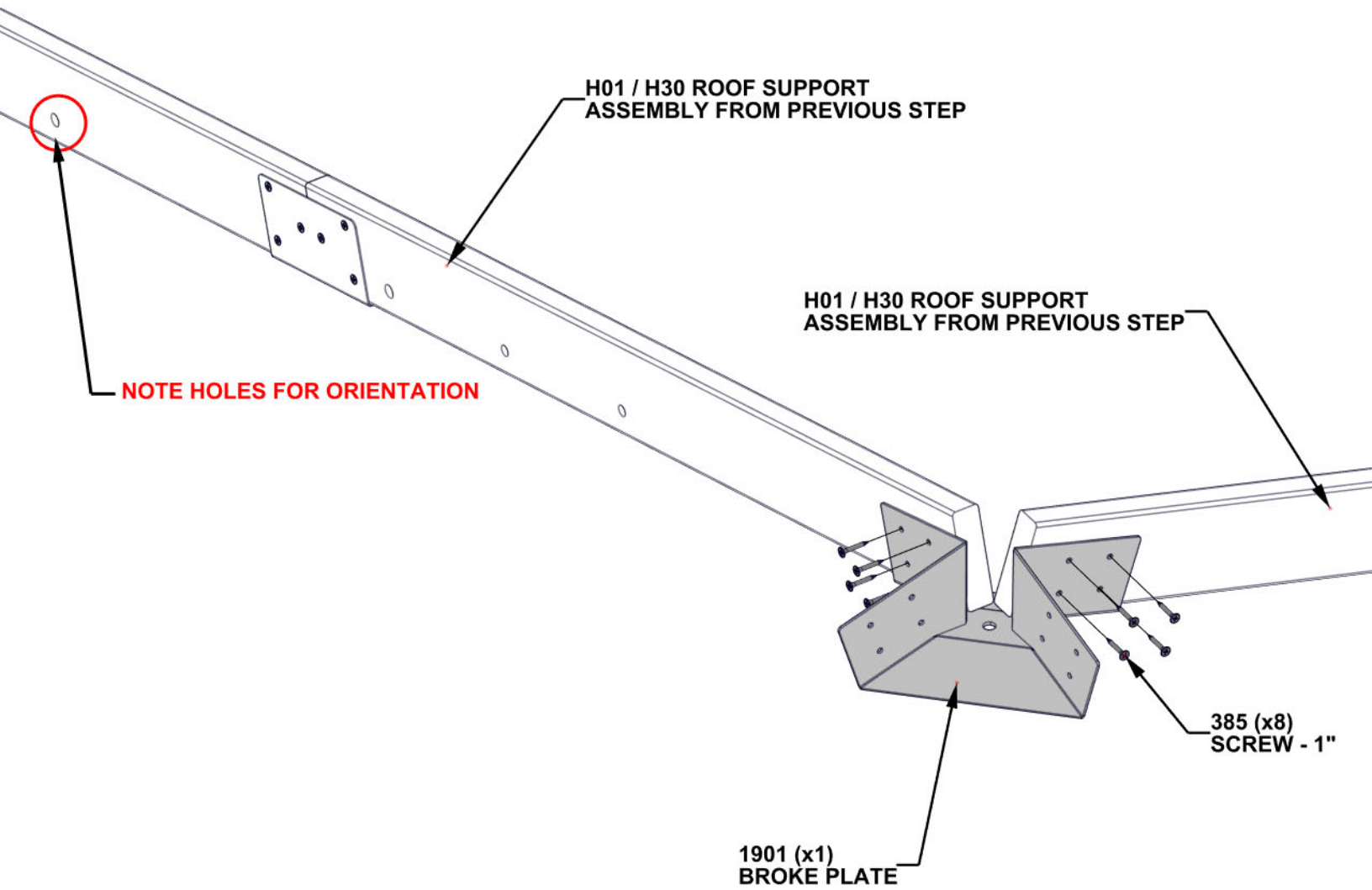

STEP 14 - ROOF SUPPORT ASSEMBLY

QTY	PART NUMBER	DESCRIPTION
1	H100354	BOLT WH 5/16 X 6 1/2 BLK
1	H101285	EYE NUT

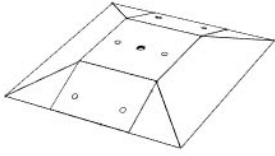

A4M01907 PEAK RIDGE CAP PLATE
(x1)



A4M01908 METAL SPACER
(x1)

- REMOVE PROTECTIVE BLUE FILM BEFORE ASSEMBLY.
- GLOVES ARE RECOMMENDED WHEN HANDLING STEEL ROOF PIECES.

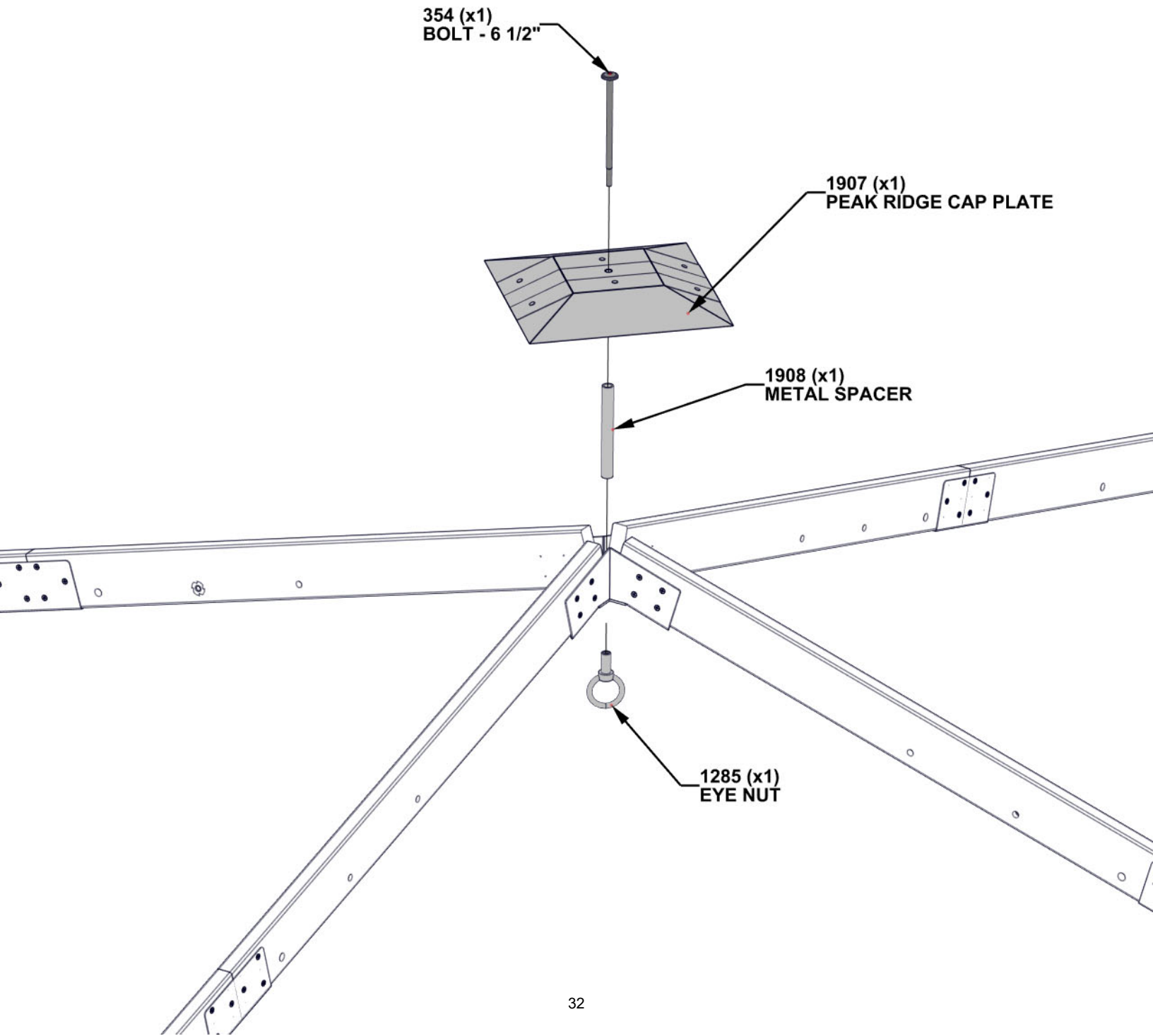

STEP 15 - ROOF SUPPORT ASSEMBLY

- 3 PEOPLE ARE RECOMMENDED FOR THIS STEP.
- POSITION 1 PERSON ON A LADDER IN THE CENTER.
- LIFT ROOF SUPPORT UP AND OVER BEAMS AND INSERT INTO CORNER POST CLIPS.

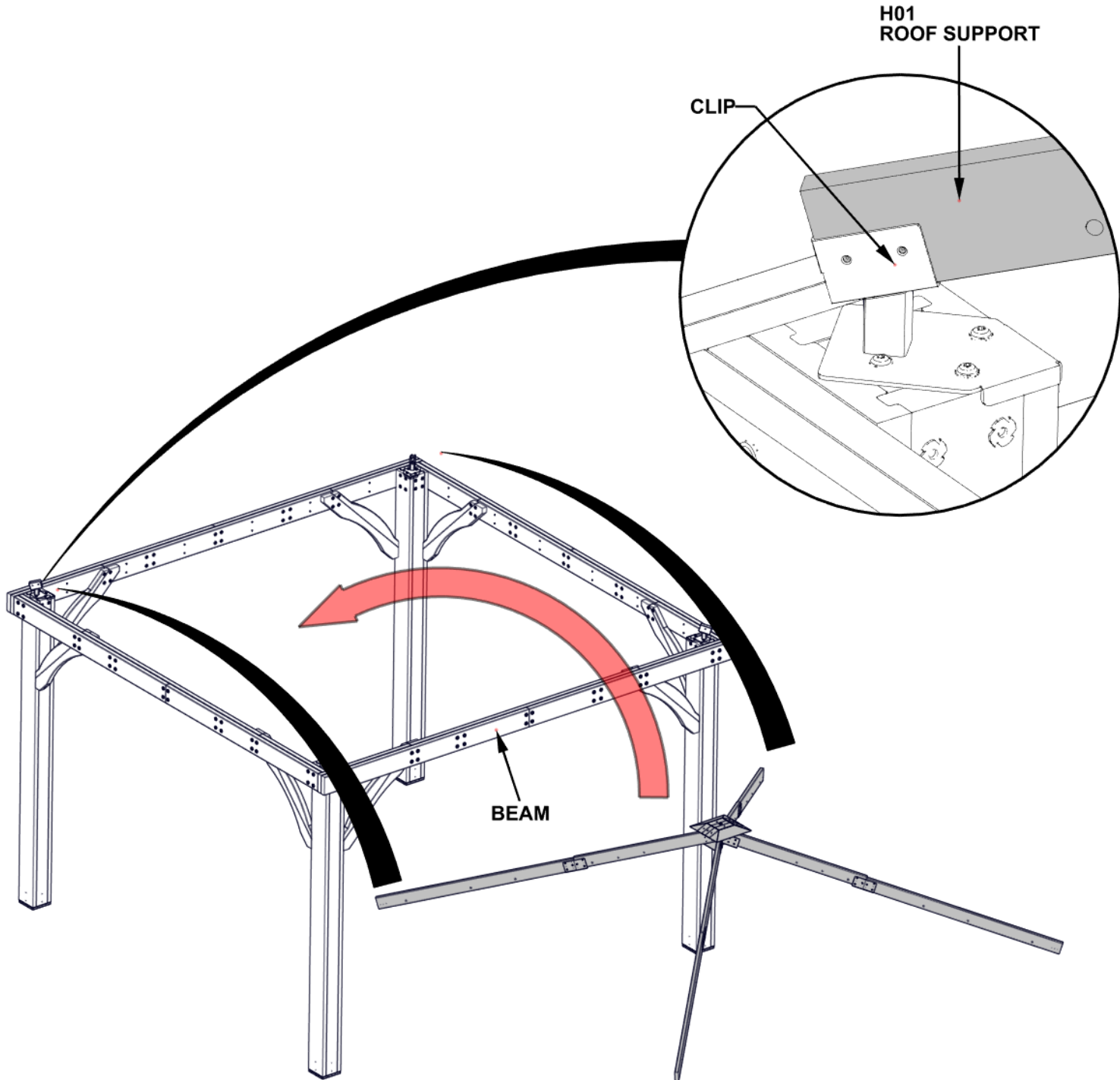

STEP 16 - ROOF SUPPORT ASSEMBLY

QTY	PART NUMBER	DESCRIPTION
12	H100385	SCREW PFH 8x1 BLK

- REPEAT ON ALL POSTS

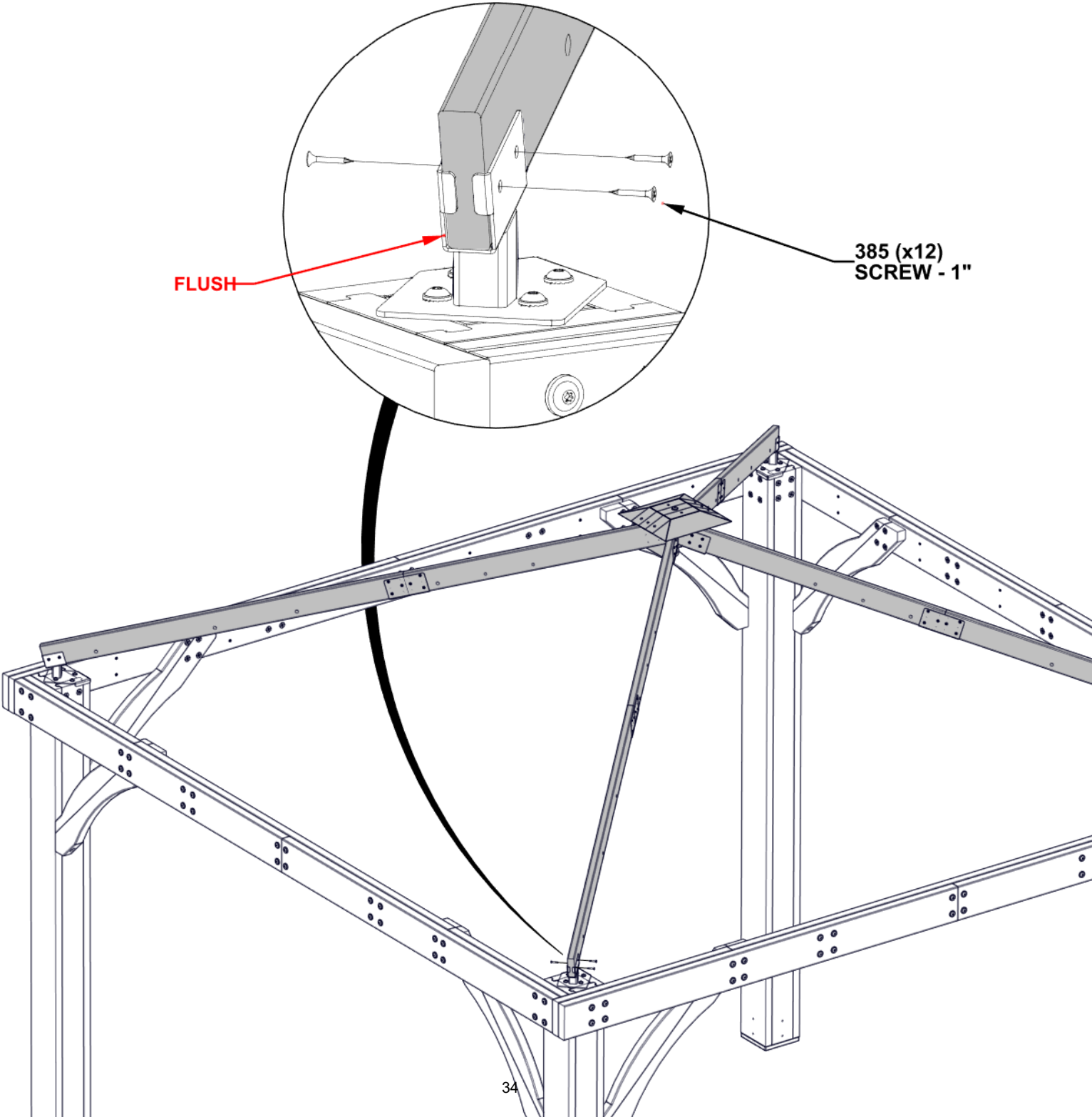

STEP 17 - SIDE ROOF PANEL ASSEMBLY



H31 TOP JOIST - W4L20290
(x1) 15/16"x3 3/8"x53 3/16" (24x86x1351)



H32 TOP JOIST - W4L20291
(x1) 15/16"x3 3/8"x53 3/16" (24x86x1351)

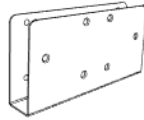

A4M01237- ROOF SUPPORT SPLICE CLIP
(x2)

QTY	PART NUMBER	DESCRIPTION
24	H100385	SCREW PFH 8x1 BLK



H11 ROOF JOIST - W4L15216
(x1) 15/16"x3 3/8"x44 1/2" (24x86x1130)



H12 ROOF JOIST - W4L15220
(x1) 15/16"x3 3/8"x44 1/2" (24x86x1130)

- INSERT BOARDS INTO EACH SIDE OF THE BRACKETS AS SHOWN
- INSERT SCREWS THROUGH EACH OF THE BRACKET HOLES ON BOTH SIDES

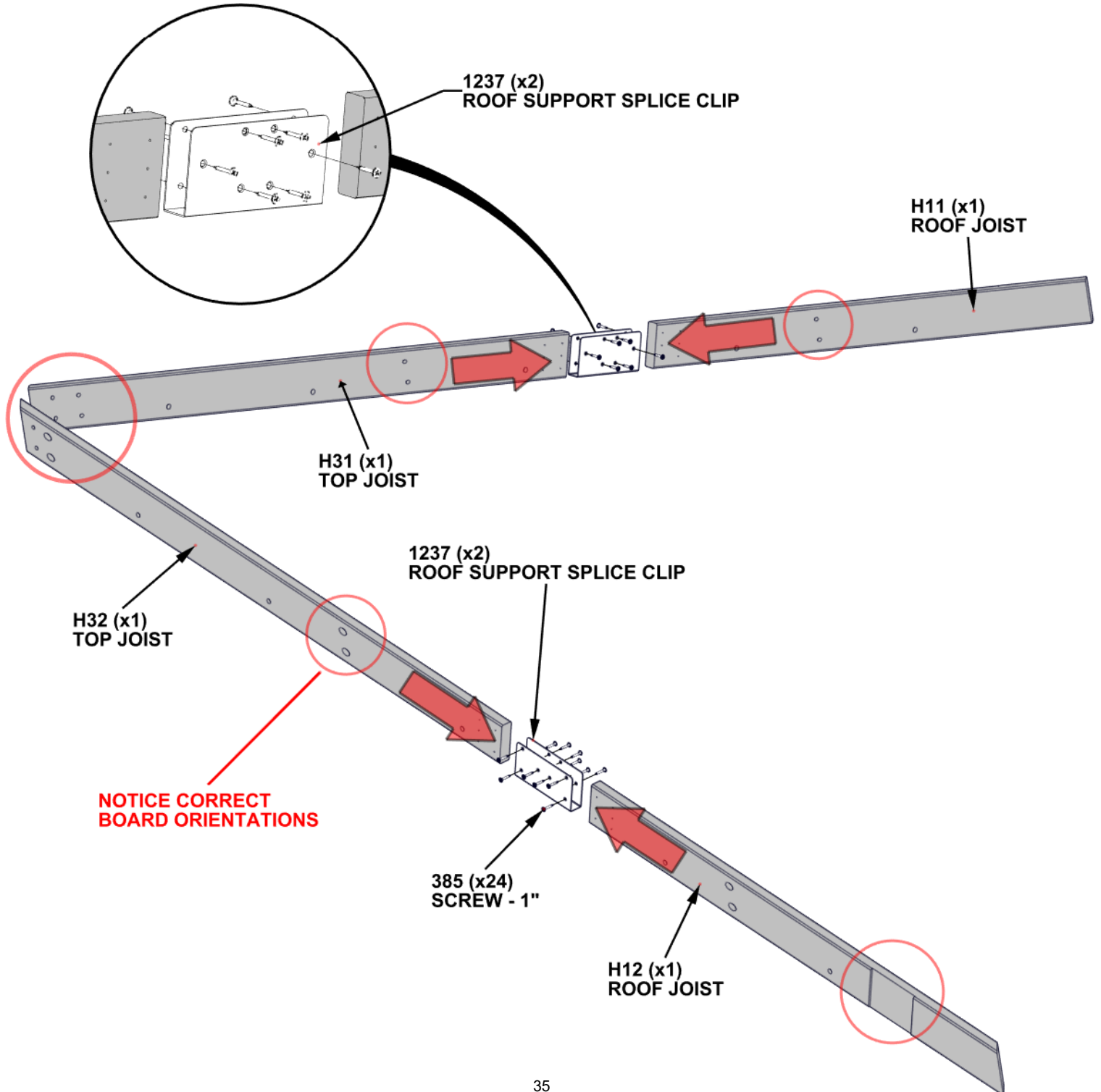

STEP 18 - SIDE ROOF PANEL ASSEMBLY

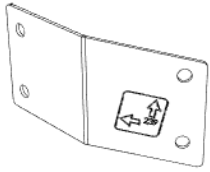

A4M01239 PANEL BRACKET
(x1)

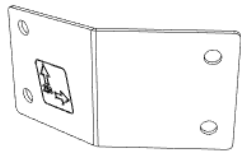

A4M01238 PANEL BRACKET
(x1)

QTY	PART NUMBER	DESCRIPTION
4	H100171	BOLT WH 1/4x1 BLK
4	H100398	T-NUT 1/4 BLK



H06 ROOF JOIST - W4L15203
(x1) 15/16"x3 3/8"x10 11/16" (24x86x272)

- INSERT T-NUTS FIRST

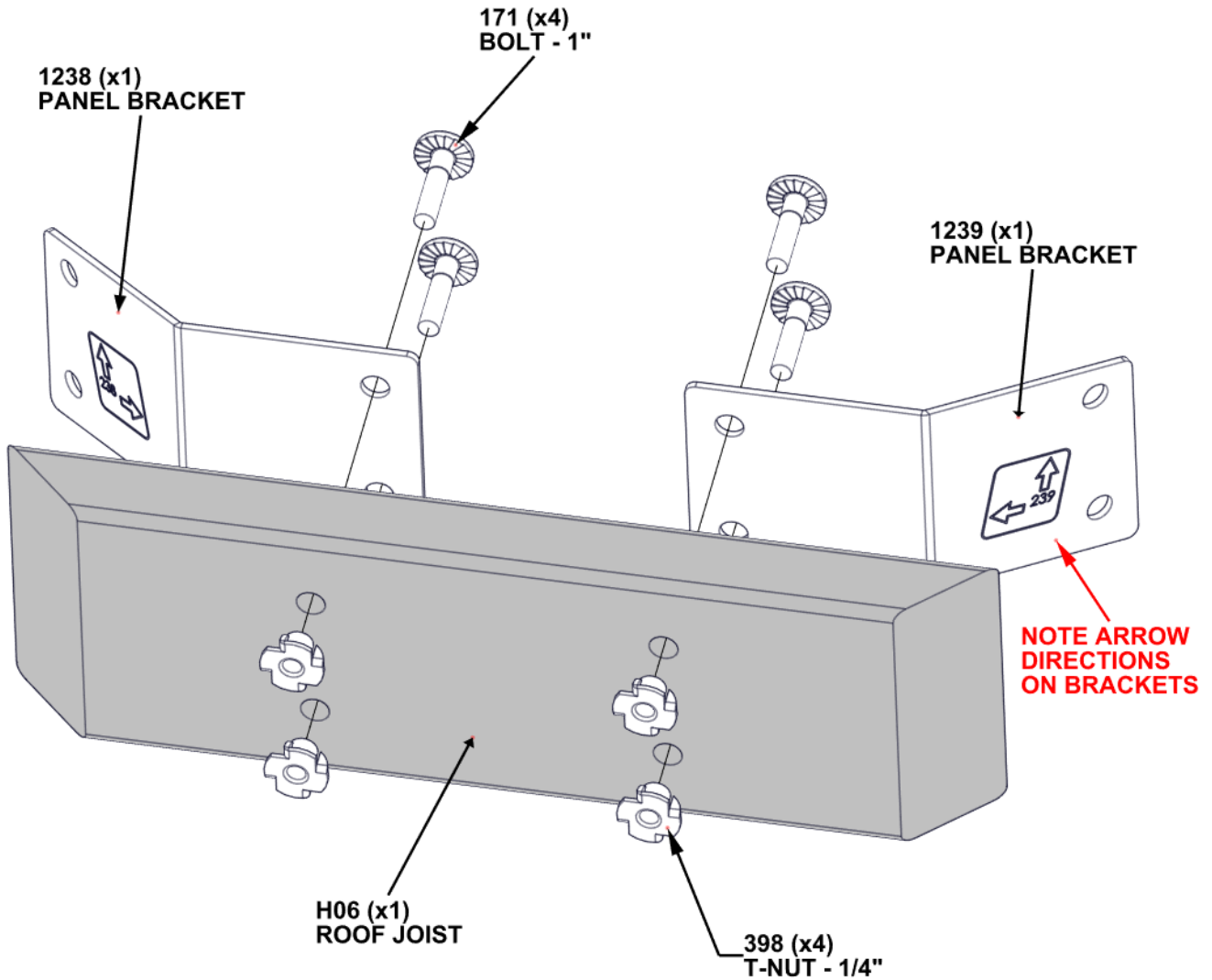

STEP 19 - SIDE ROOF PANEL ASSEMBLY

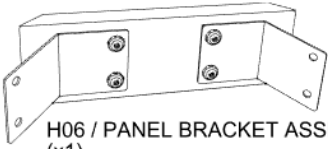

H06 / PANEL BRACKET ASSEMBLY (x1)

QTY	PART NUMBER	DESCRIPTION
4	H100171	BOLT WH 1/4x1 BLK
4	H100398	T-NUT 1/4 BLK

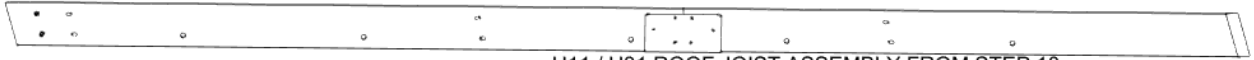

H11 / H31 ROOF JOIST ASSEMBLY FROM STEP 18 (x1)



H12 / H32 ROOF JOIST ASSEMBLY FROM STEP 18 (x1)

- INSERT T-NUTS FIRST

H06 / PANEL BRACKET ASSEMBLY

H11 / H31 ROOF JOIST ASSEMBLY

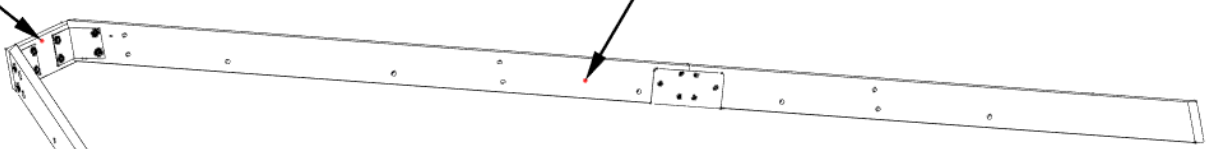

COMPLETED VIEW

H12 / H32 ROOF JOIST ASSEMBLY

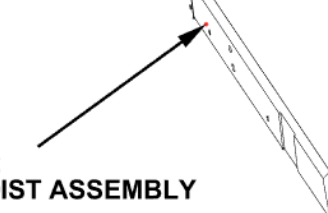

H06 (x1) ROOF JOIST

398 (x4) T-NUT - 1/4"

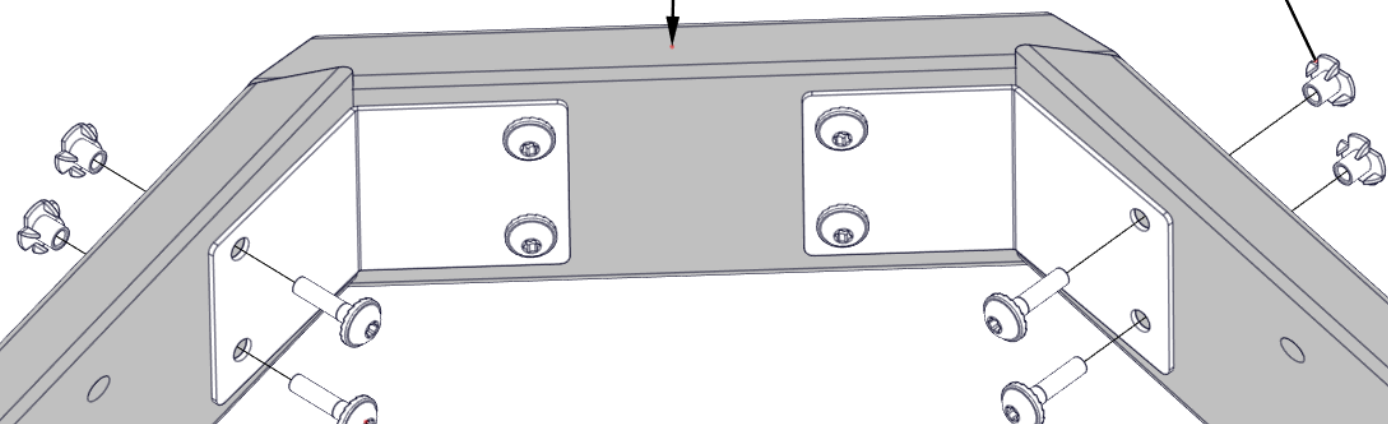

171 (x4) BOLT - 1"

STEP 20 - SIDE ROOF PANEL ASSEMBLY



E13 RAFTER - W4L15219
(x1) 1 7/16"x3 3/8"x21 15/16" (36x86x557)



E07 RAFTER - W4L15209
(x1) 1 3/8"x3 3/8"x22" (36x86x557)

QTY	PART NUMBER	DESCRIPTION
12	H101030	CONFIRMAT - SCREW 2"



E11 RAFTER - W4L15217
(x1) 1 7/16"x3 3/8"x69" (36x86x1752)

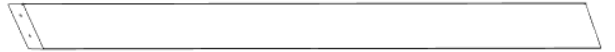

E12 RAFTER - W4L15218
(x1) 1 7/16"x3 3/8"x45 7/16" (36x86x1155)



E05 RAFTER - W4L15207
(x1) 1 7/16"x3 3/8"x69" (36x86x1752)



E06 RAFTER - W4L15208
(x1) 1 7/16"x3 3/8"x45 7/16" (36x86x1155)

**NOTE PILOT HOLES ARE
FACE UP ON ALL RAFTERS**

1030 (x12)
CONFIRMAT SCREW - 2"

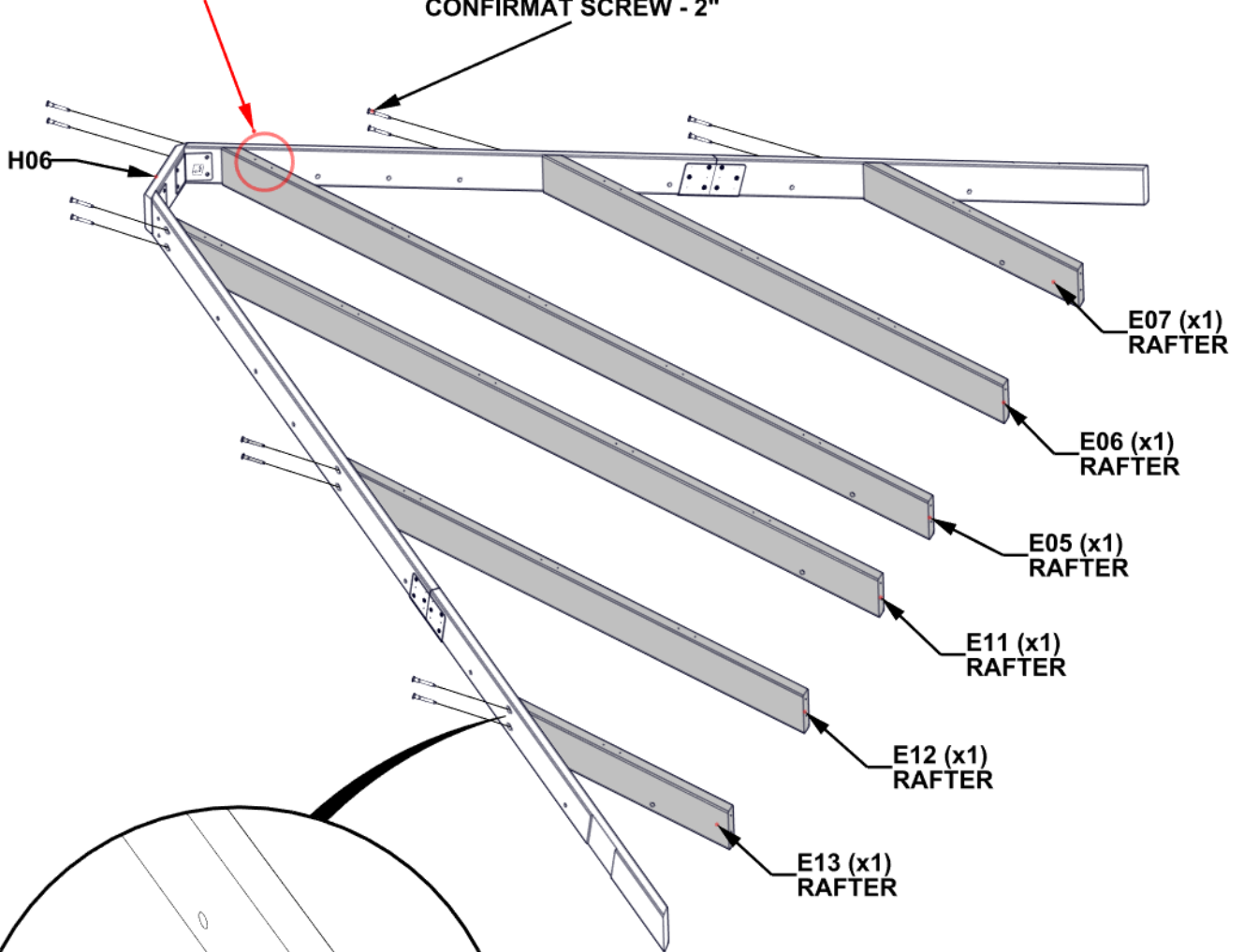

STEP 21 - SIDE ROOF PANEL ASSEMBLY



Q04 ROOF JOIST - W4L17578
(x1) 24x4 7/16"x79 7/16" (24x112x2018)

QTY	PART NUMBER	DESCRIPTION
4	H100382	SCREW PFH 8x1 3/4 BLK
12	H101030	CONFIRMAT - SCREW 2"



Q02 ROOF JOIST - W4L17579
(x1) 15/16"x4 7/16"x64 15/16" (24x112x1649)

- USE Q04/Q02 BOARDS AS GUIDES, & A 1/8" DRILL BIT, TO DRILL PILOT HOLES INTO THE H12/11 BOARDS
- RAFTERS MAY NEED TO BE LOOSENED TO ATTACH Q04 & Q02 TO H12/11

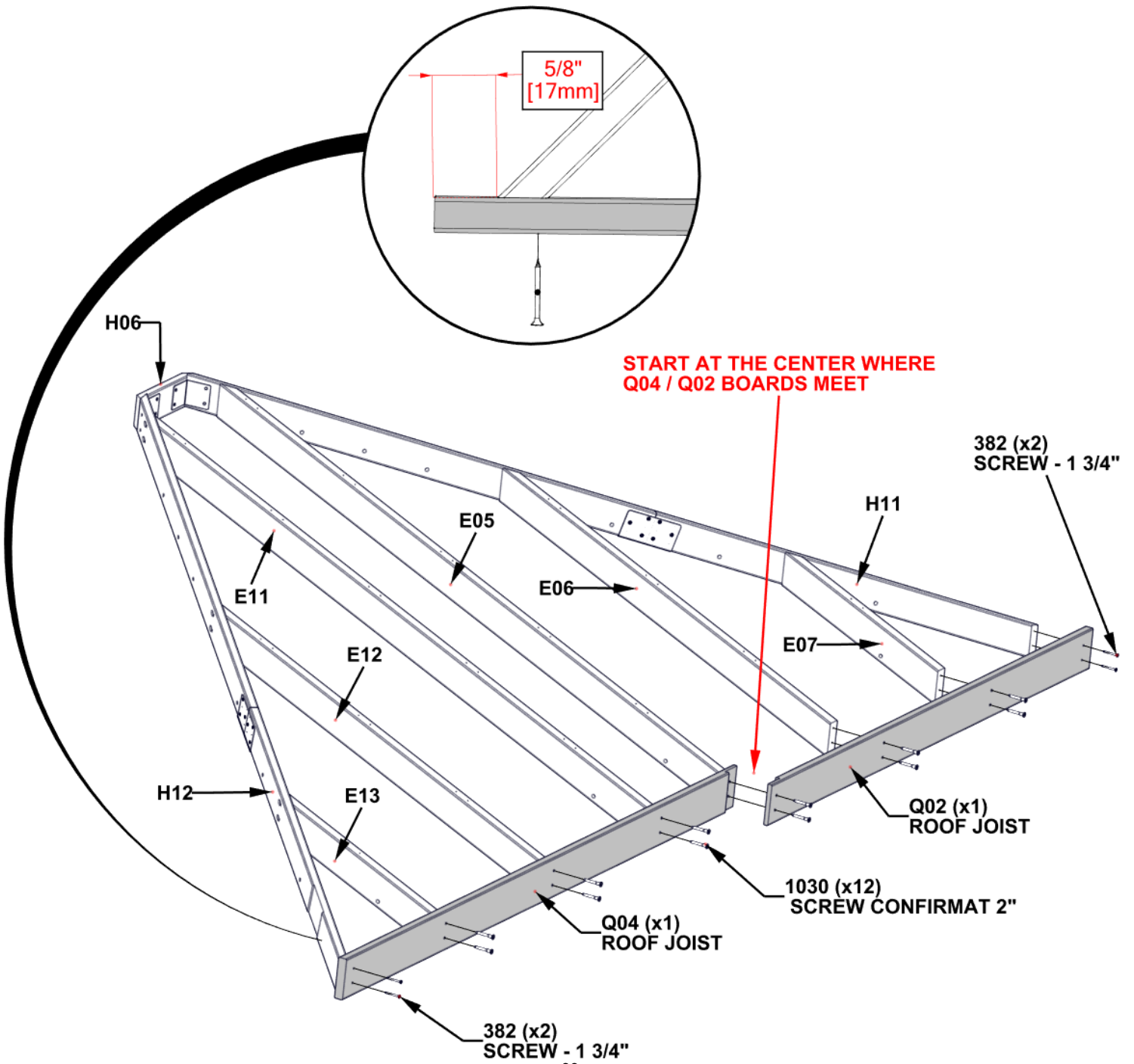

STEP 22 - SIDE ROOF PANEL ASSEMBLY

CRITICAL

- SQUARE UNIT BEFORE PROCEEDING TO NEXT STEPS.
- THE BELOW DIMENSIONS ARE CRITICAL TO THE FINAL ROOF ASSEMBLY.
- MEASUREMENTS SHOULD BE WITHIN $\pm 1/4"$.
- MEASUREMENTS OUTSIDE OF TOLERANCE WILL LEAD TO THE INABILITY TO ASSEMBLE THE ROOF

- LOOSEN HARDWARE TO ADJUST FOR SQUARING IF NEEDED

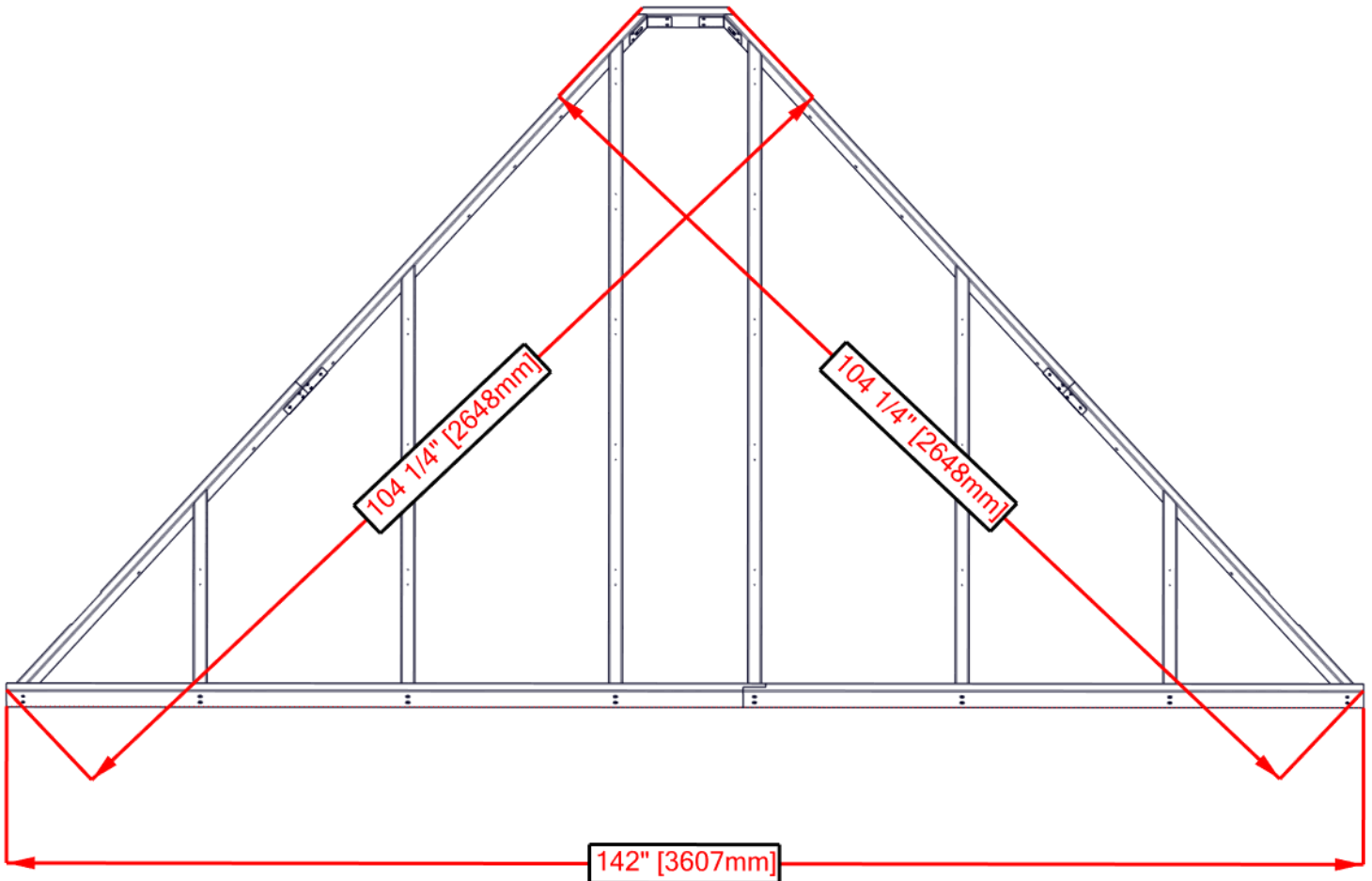

STEP 23 - SIDE ROOF PANEL ASSEMBLY

QTY	PART NUMBER	DESCRIPTION
36	H100391	SCREW PFH 8x2 BLK

H24 PURLIN - W4L15232
(x1) 15/16"x3 3/8"x27 1/4" (24x86x692)

H21 PURLIN - W4L15230
(x1) 15/16"x3 3/8"x75 11/16" (24x86x1922)

H19 PURLIN - W4L15228
(x1) 15/16"x3 3/8"x58 3/8" (24x86x1483)

H20 PURLIN - W4L15229
(x1) 15/16"x3 3/8"x43 7/8" (24x86x1114)

H28 PURLIN - W4L15238
(x1) 15/16"x3 3/8"x70 1/2" (24x86x1791)

H27 PURLIN - W4L15237
(x1) 15/16"x3 3/8"x56" (24x86x1422)

H22 PURLIN - W4L15231
(x1) 15/16"x3 3/8"x51 7/16" (24x86x1307)

- ALIGN PURLIN PILOT HOLES WITH RAFTER PILOT HOLES
- ATTACH SCREWS FROM THE CENTER AND WORK OUTWARD

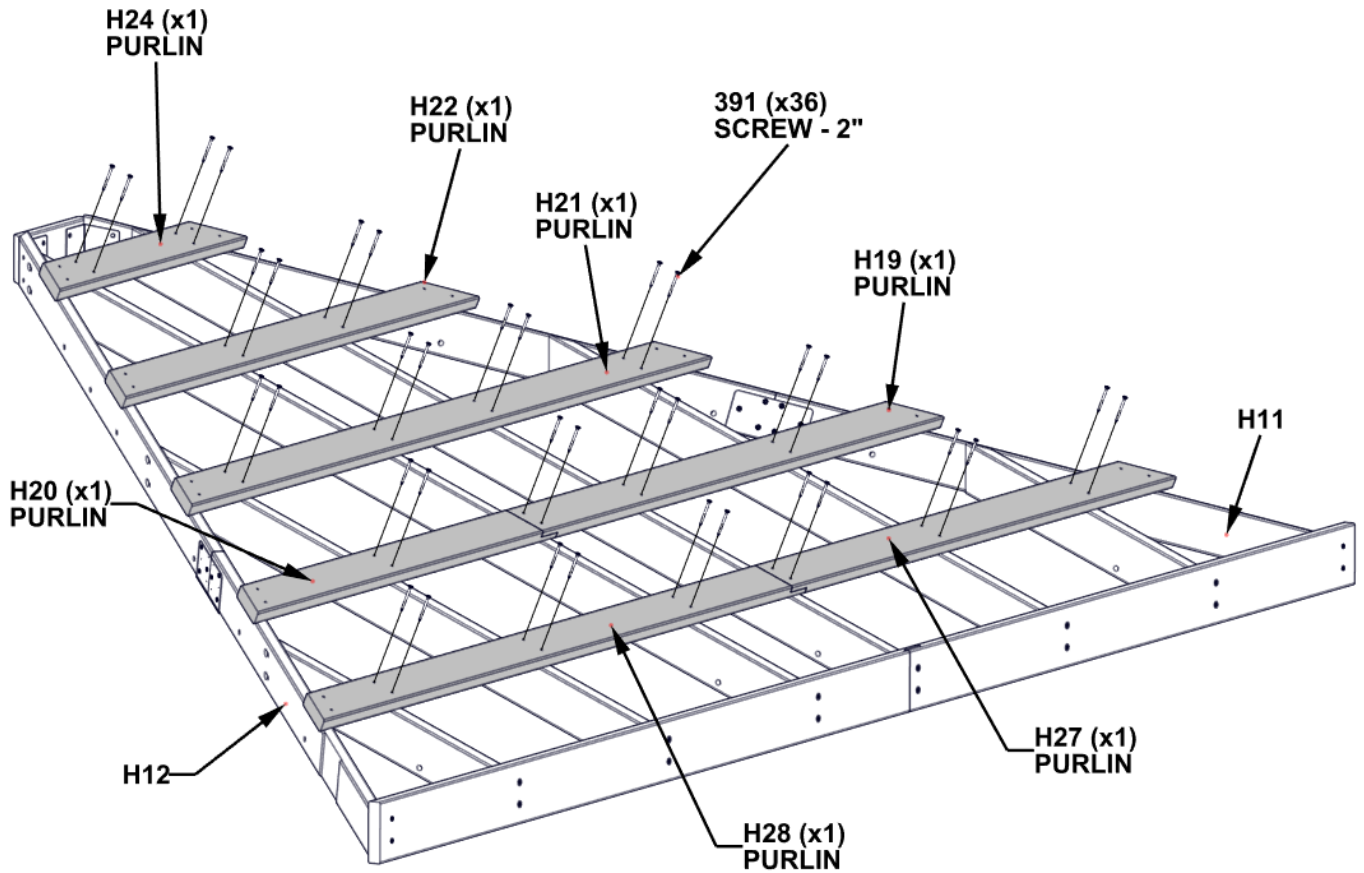

STEP 24 - SIDE ROOF PANEL ASSEMBLY



T02 PURLIN - W4L15239
(x1) 15/16"x1 5/16"x12 7/8" (24x34x327)

QTY	PART NUMBER	DESCRIPTION
22	H100391	SCREW PFH 8x2 BLK

- H07, H08, H11, & H12 BOARDS DO NOT HAVE PILOT HOLES FOR OUTSIDE EDGE SCREWS
- USING THE PURLINS AS A GUIDE AND A 1/8" DRILL BIT, DRILL PILOT HOLES INTO H12/H08/H11/H07 BOARDS

- IF PURLINS OVERHANG MORE THAN 5/8" CUT DOWN TO 5/8"

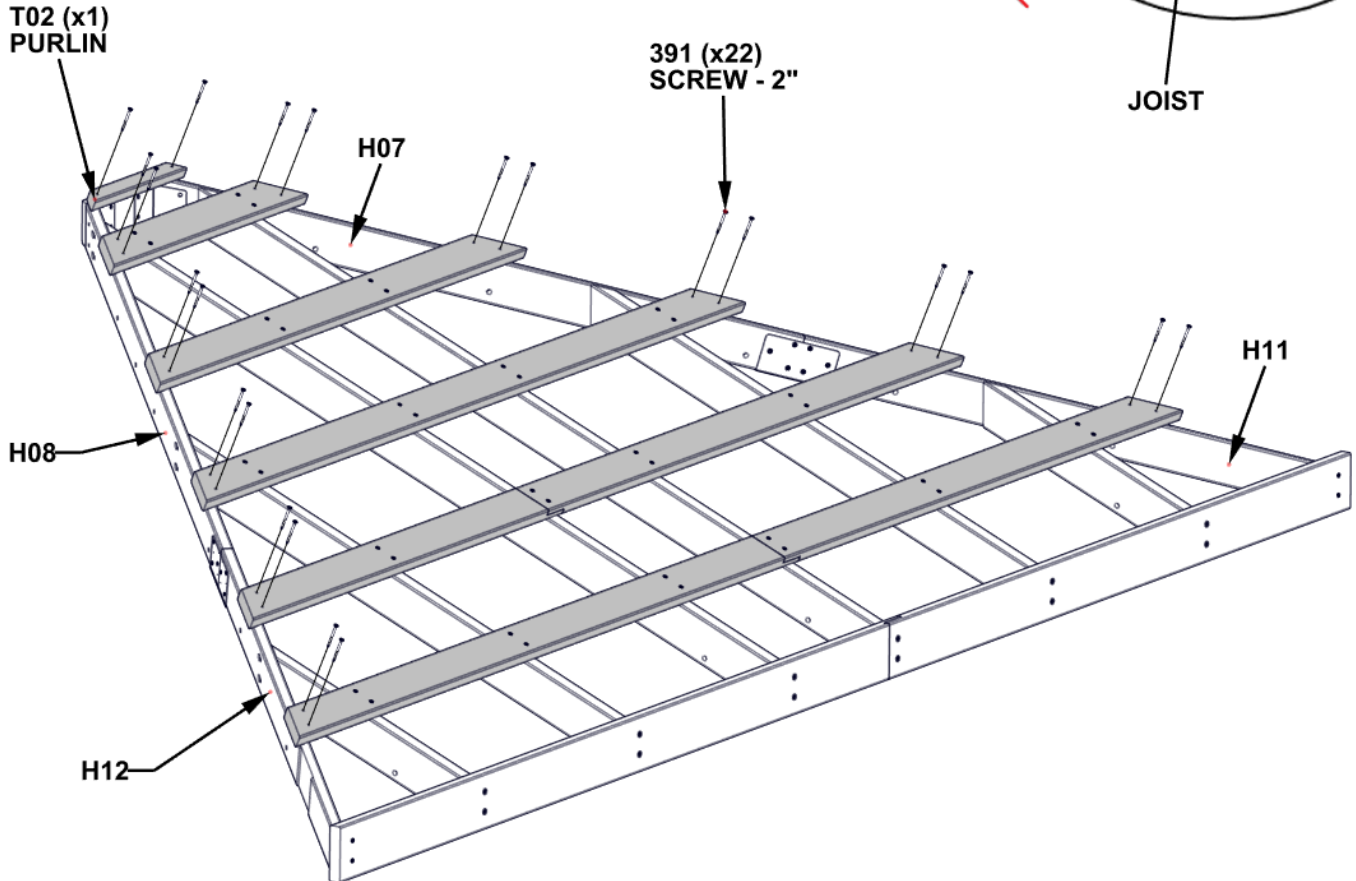
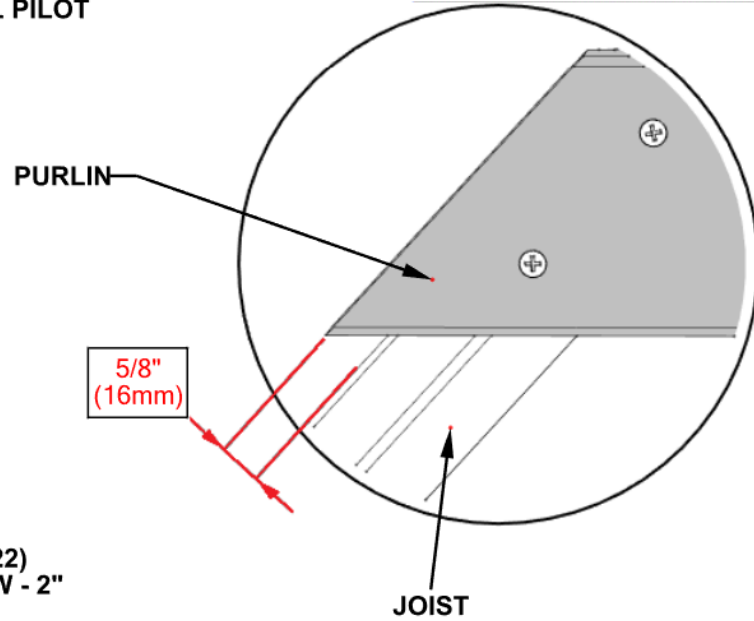

STEP 25 - SIDE ROOF PANEL ASSEMBLY

29GA STEEL SHEETING - A4M01923-1
(x1) 0.02x30 11/16"x14 1/4"

29GA STEEL SHEETING - A4M01922-2
(x1) 0.02x30 11/16"x45 5/16"

29GA STEEL SHEETING - A4M01922-1
(x1) 0.02x30 11/16"x45 5/16"

29GA STEEL SHEETING - A4M01924-2
(x1) 0.02x30 11/16"x32 15/16"

29GA STEEL SHEETING - A4M01923-2
(x1) 0.02x30 11/16"x14 1/4"

29GA STEEL SHEETING - A4M01924-1
(x1) 0.02x30 11/16"x32 15/16"

- REMOVE PROTECTIVE BLUE FILM. THIS SIDE WILL FACE UP.
- STARTING IN THE CENTER, PLACE PANELS AS SHOWN BELOW.
- OVERLAP PANELS BY ONE RIDGE.
- PANELS SHOULD BE FLUSH WITH PURLIN END AND ROOF JOIST.

WARNING: GLOVES ARE RECOMMENDED WHEN HANDLING STEEL ROOF SHEETING

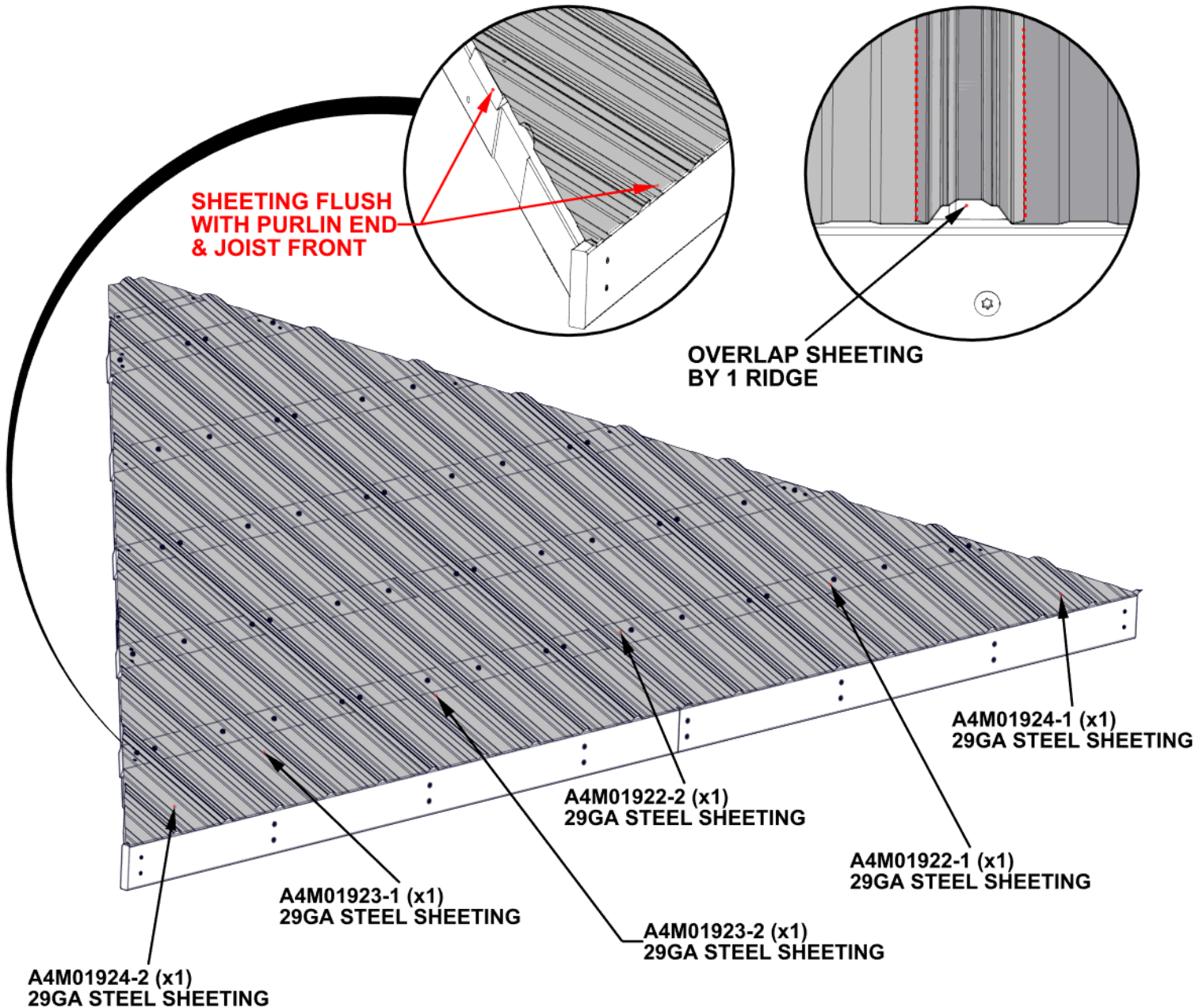

STEP 26 - SIDE ROOF PANEL ASSEMBLY

QTY	PART NUMBER	DESCRIPTION
46	H100833	SCREW WOODGRIP 10-16x3/4

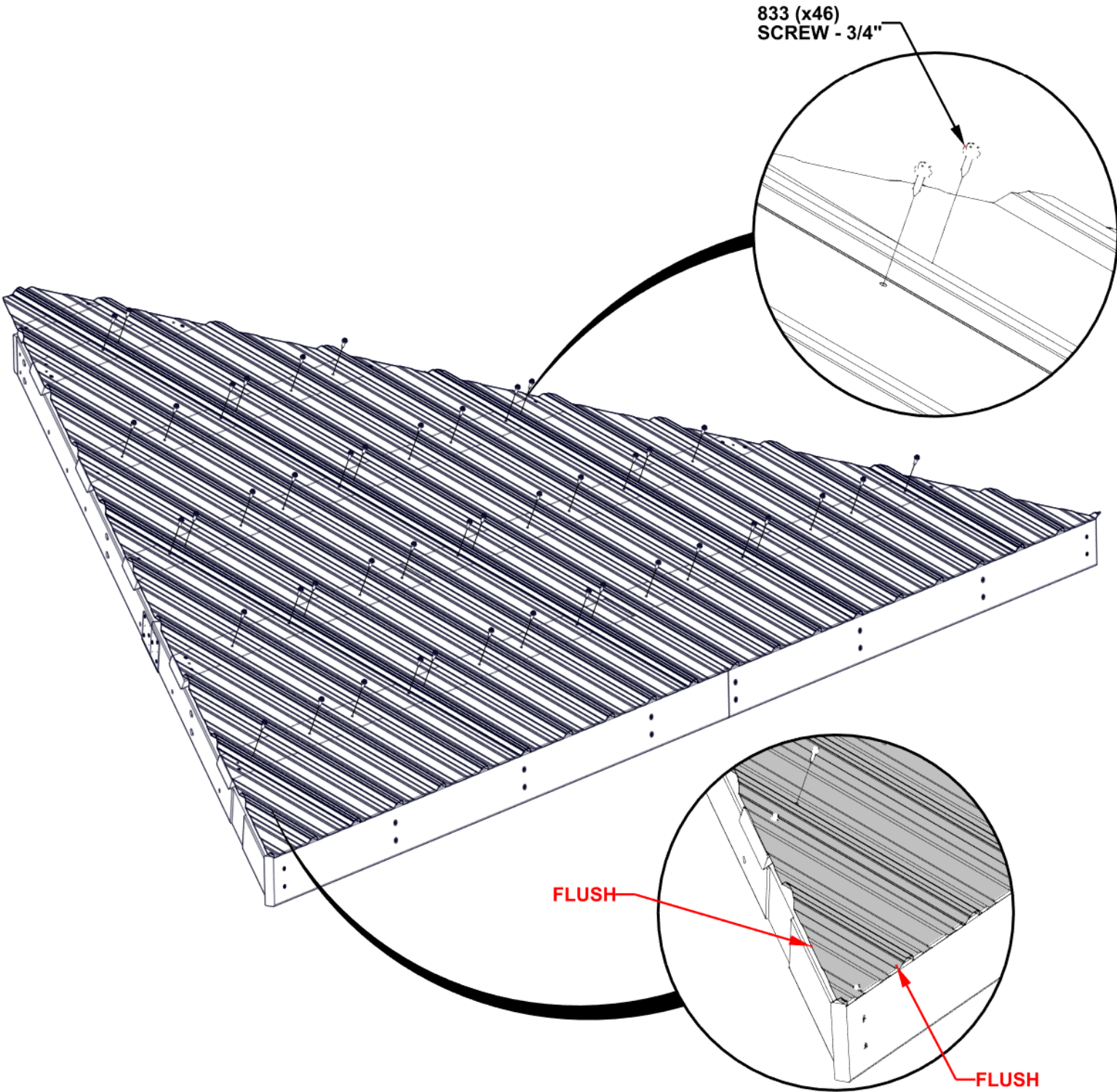

STEP 27 - SIDE ROOF PANEL ASSEMBLY

QTY	PART NUMBER	DESCRIPTION
6	H100833	SCREW WOODGRIP 10-16x3/4"

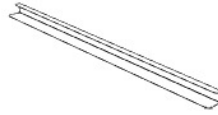
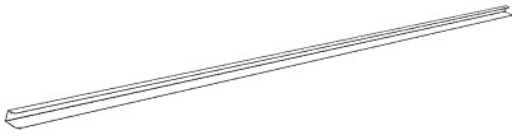

A4M02847 - RIDGE CAP CHANNEL LONG
(x2)

A4M02850 - RIDGE CAP CHANNEL SHORT
(x2)

- POSITION THE RIDGE CAP CHANNEL OVER THE EDGE OF THE ROOF PANELS WITH THE WIDER SIDE OF THE CHANNEL ON THE BOTTOM
- MAKE SURE THE PANELS ARE FULLY SEATED INTO THE CHANNEL.
- FLUSH THE TOP OF THE CHANNEL WITH THE TOP OF THE METAL PANELS
- NOTE IT MAY BE NECESSARY TO LOOSEN SOME OF THE OUTSIDE SCREWS FROM STEP 26

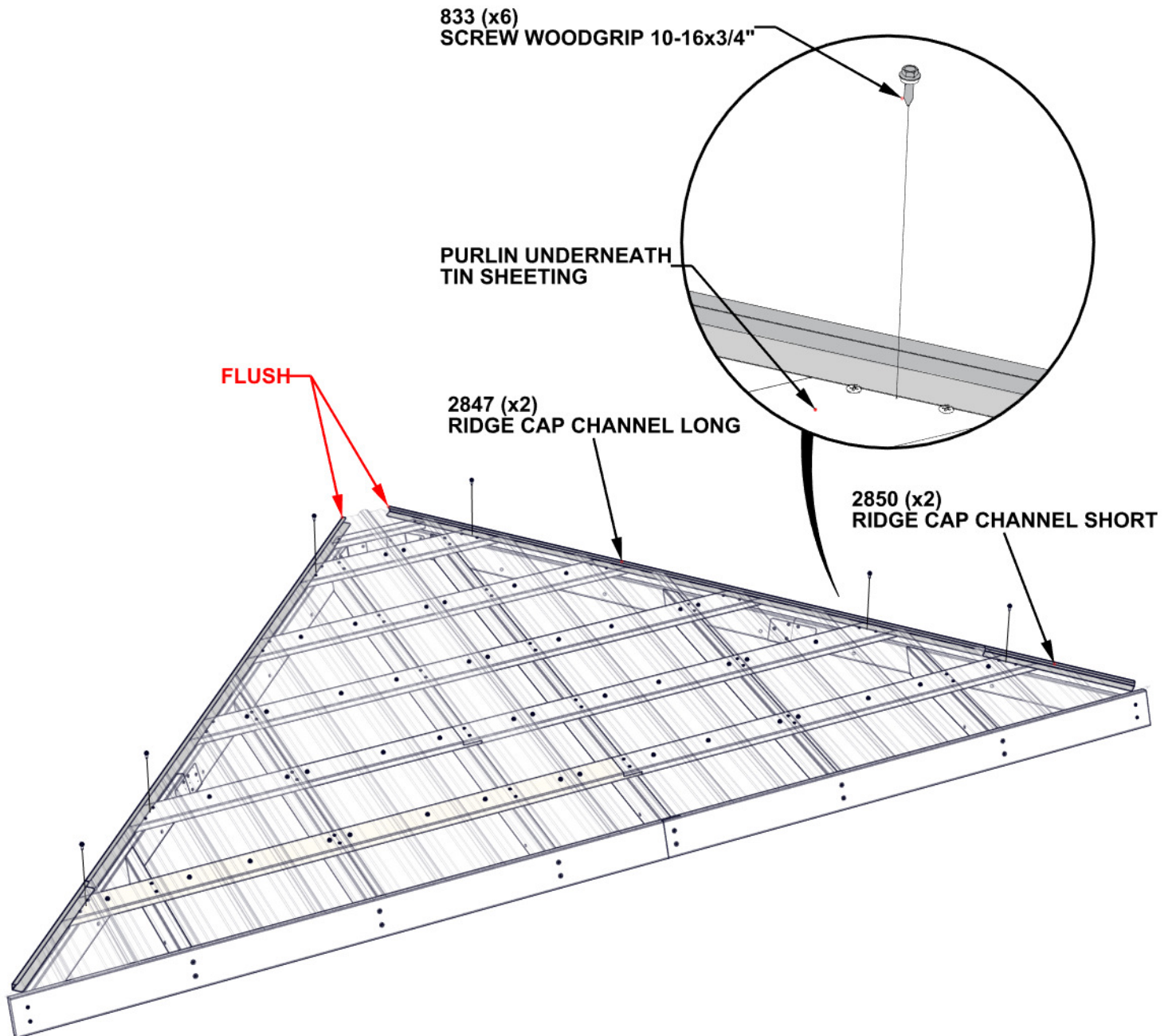

**REPEAT ROOF PANEL ASSEMBLY
STEPS 17 THROUGH 27**

STEP 28 - ROOF PANEL ATTACHMENT

QTY	PART NUMBER	DESCRIPTION
4	H100379	T-NUT 5/16 BLK

- INSERT T-NUTS AS SHOWN

- CORRECT T-NUT PLACEMENT IS CRITICAL TO REMAINING STEPS

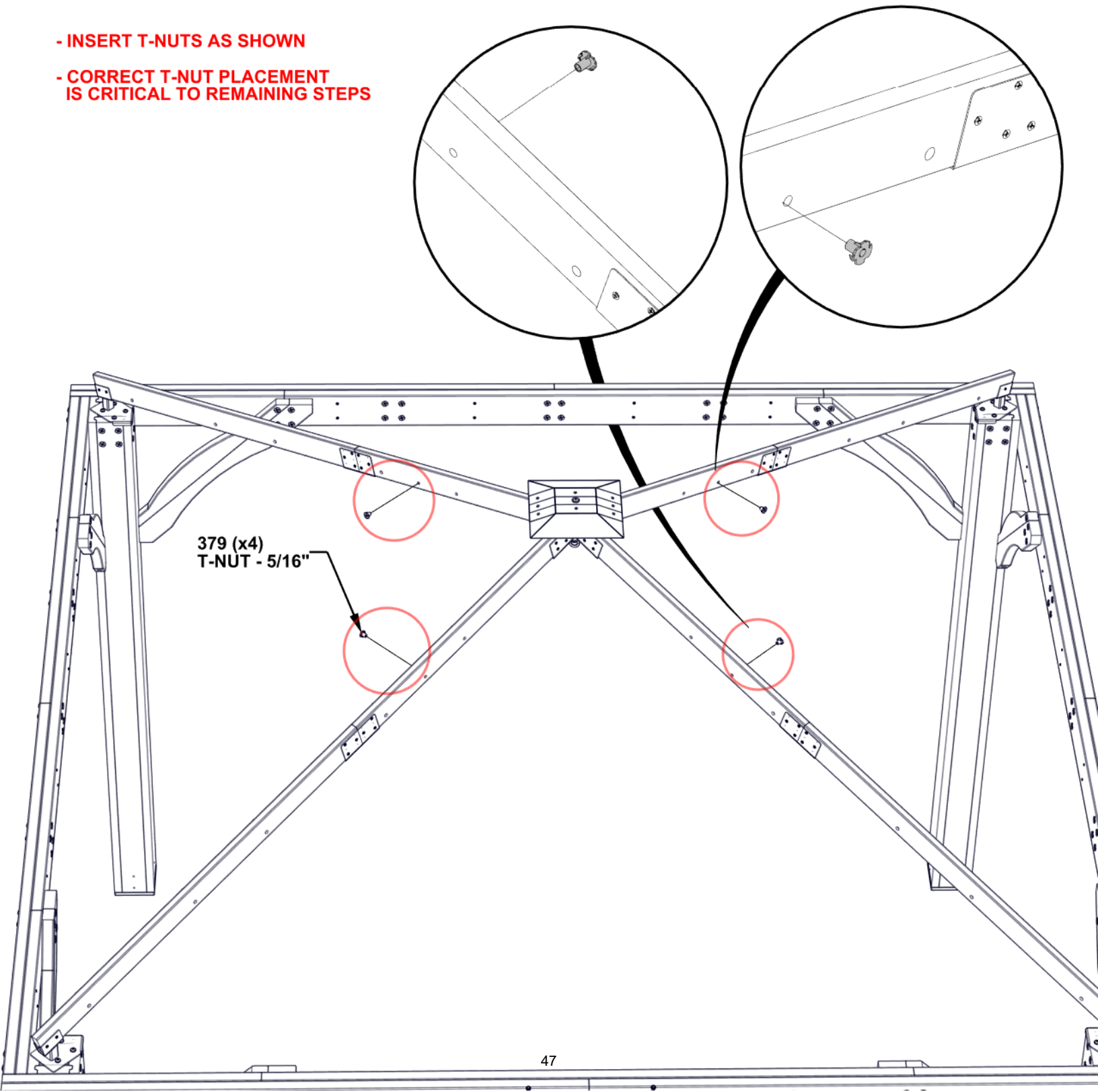

STEP 29 - ROOF PANEL ATTACHMENT

QTY	PART NUMBER	DESCRIPTION
4	H100198	WASHER LOCK EXT 8x19
4	H100378	BOLT WH 5/16x1 3/4 BLK

- 3 PEOPLE ARE RECOMMENDED FOR THIS STEP.
- POSITION A PERSON ON A LADDER IN THE CENTER OF THE GAZEBO TO HELP SUPPORT THE ROOF PANEL
- WITH 2 PEOPLE, WORK THE PANEL UP WITHOUT SLIDING OR DRAGGING, UNTIL IT MEETS THE ROOF SUPPORT FRAME.
- MAKE SURE THE ROOF PANEL SLIDES UNDERNEATH THE RIDGE CAP.
- PLACE BOLTS WITH WASHER INTO THE T-NUTS INSTALLED DURING THE PREVIOUS STEP ON BOTH SIDES.

- REPEAT THIS STEP FOR THE OTHER SIDE ROOF PANEL ON THE OPPOSITE SIDE.

VIEW FROM BELOW ROOF PANEL

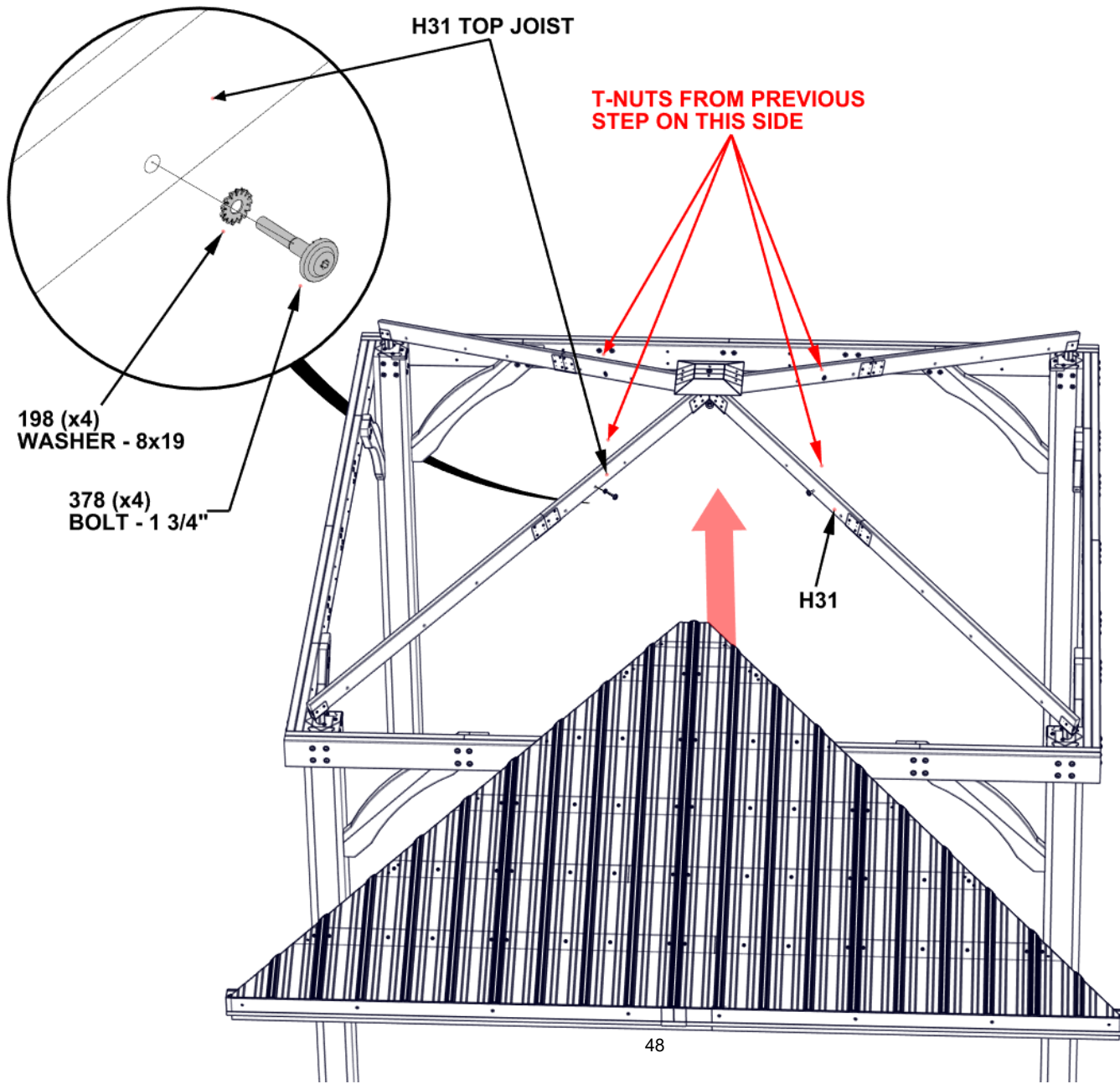

STEP 30 - FRONT / BACK ROOF PANEL ASSEMBLY



H07 ROOF JOIST - W4L15205
(x1) 15/16"x3 3/8"x53 3/16" (24x86x1351)

QTY	PART NUMBER	DESCRIPTION
24	H100385	SCREW PFH 8x1 BLK



H08 ROOF JOIST - W4L15206
(x1) 15/16"x3 3/8"x53 3/16" (24x86x1351)



H11 ROOF JOIST - W4L15216
(x1) 15/16"x3 3/8"x44 1/2" (24x86x1130)

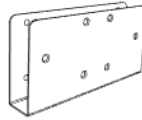

A4M01237 - ROOF SUPPORT SPLICE CLIP
(x2)



H12 ROOF JOIST - W4L15220
(x1) 15/16"x3 3/8"x44 1/2" (24x86x1130)

- INSERT BOARDS INTO EACH SIDE OF THE BRACKETS AS SHOWN
- INSERT SCREWS THROUGH EACH OF THE BRACKET HOLES ON BOTH SIDES

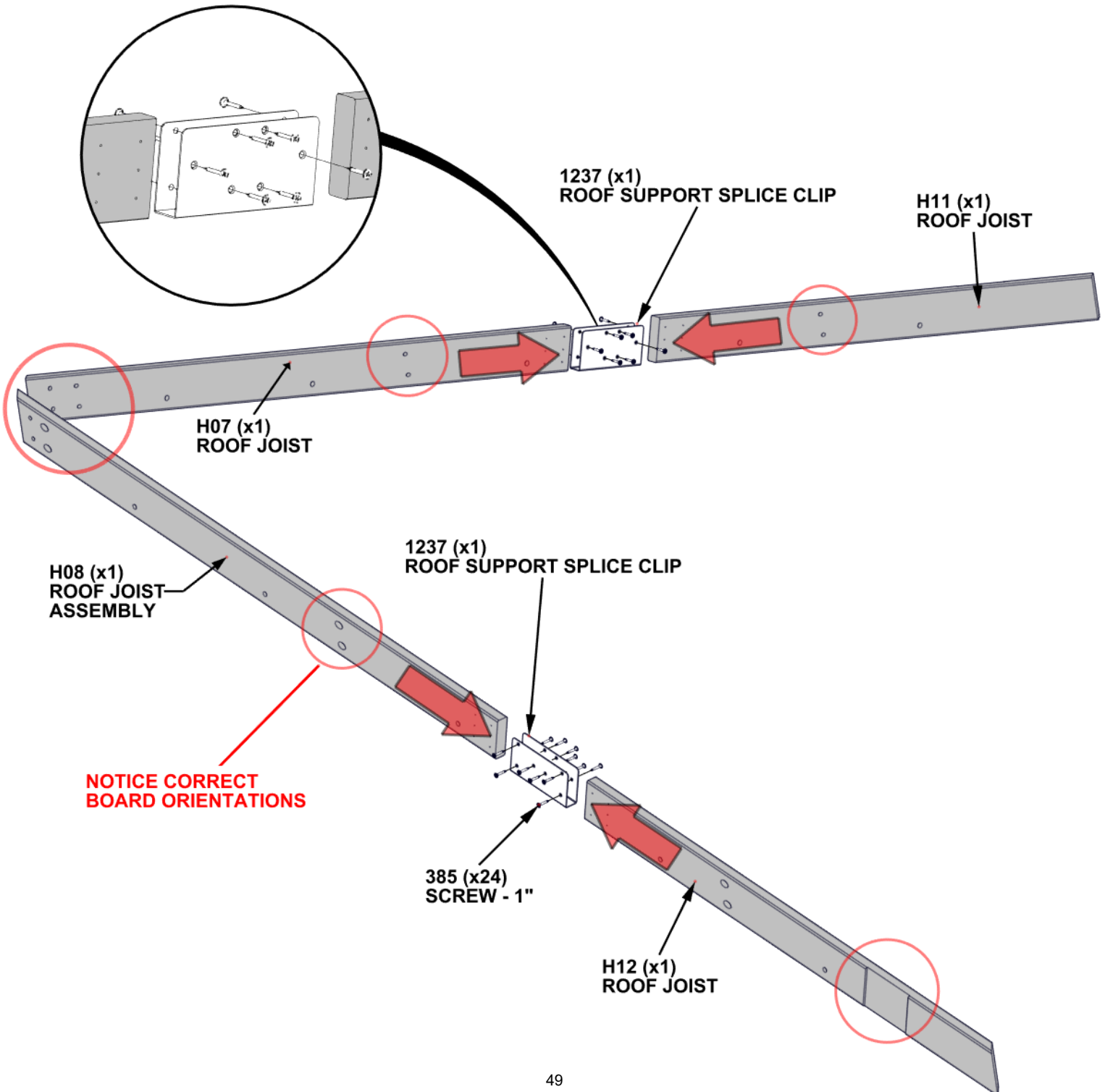

STEP 31 - FRONT / BACK ROOF PANEL ASSEMBLY

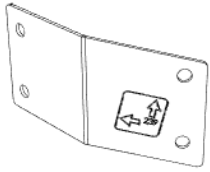

A4M01239 - PANEL BRACKET
(x1)

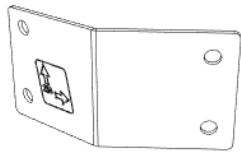

A4M01238 - PANEL BRACKET
(x1)

QTY	PART NUMBER	DESCRIPTION
4	H100171	BOLT WH 1/4x1 BLK
4	H100398	T-NUT 1/4 BLK

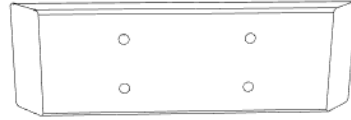

H06 ROOF JOIST - W4L15203
(x1) 15/16"x3 3/8"x10 11/16" (24x86x272)

- INSERT T-NUTS FIRST

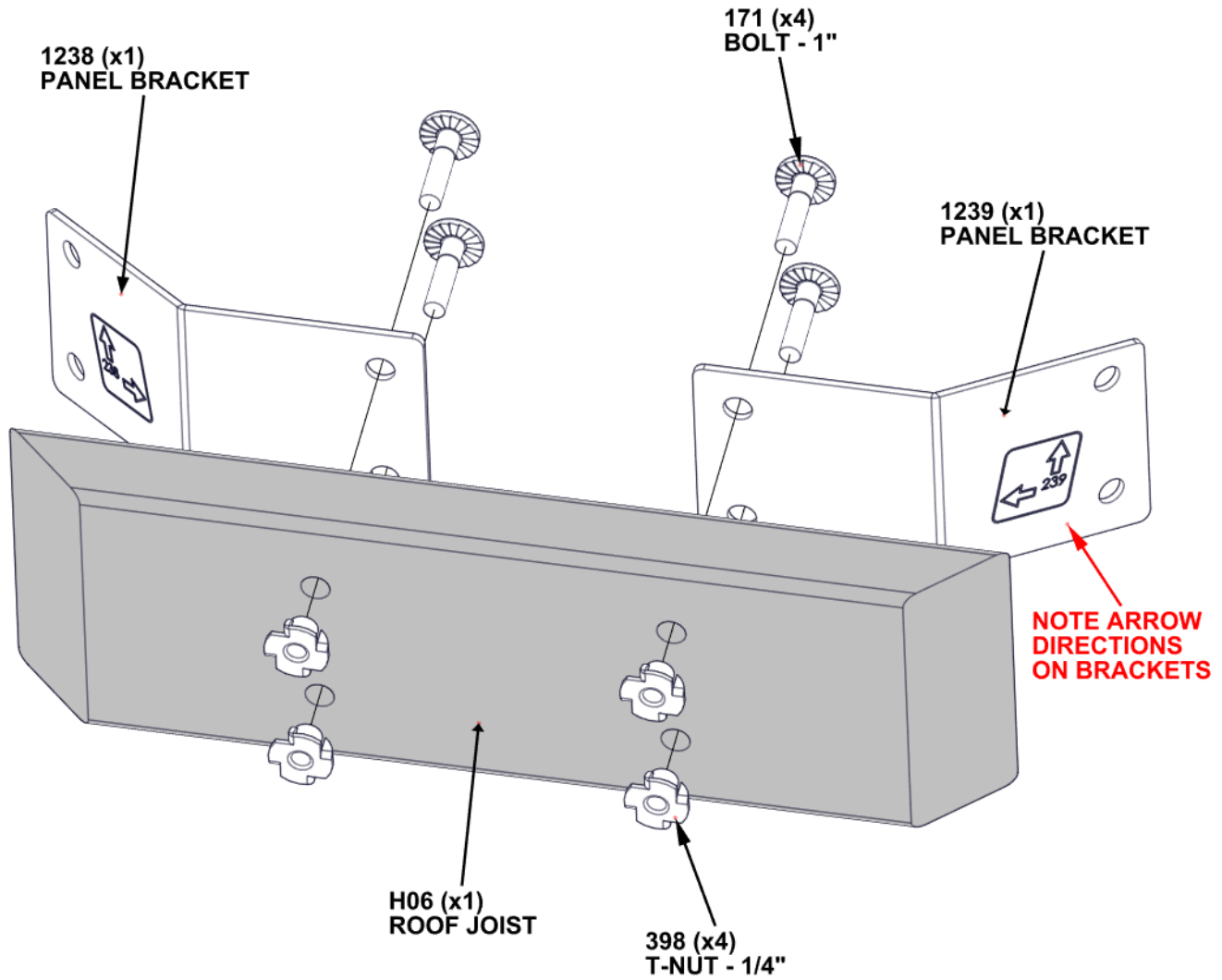

STEP 32 - FRONT / BACK ROOF PANEL ASSEMBLY

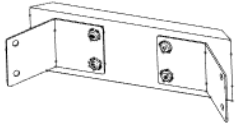

H06 / PANEL BRACKET ASSEMBLY
(x1)

QTY	PART NUMBER	DESCRIPTION
4	H100171	BOLT WH 1/4x1 BLK
4	H100398	T-NUT 1/4 BLK

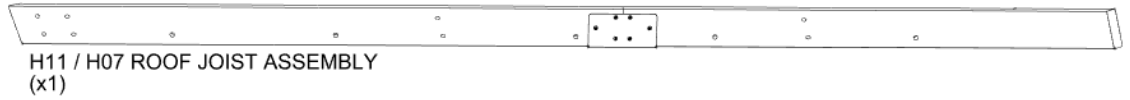

H11 / H07 ROOF JOIST ASSEMBLY
(x1)



H12 / H08 ROOF JOIST ASSEMBLY
(x1)

- INSTALL T-NUTS FIRST

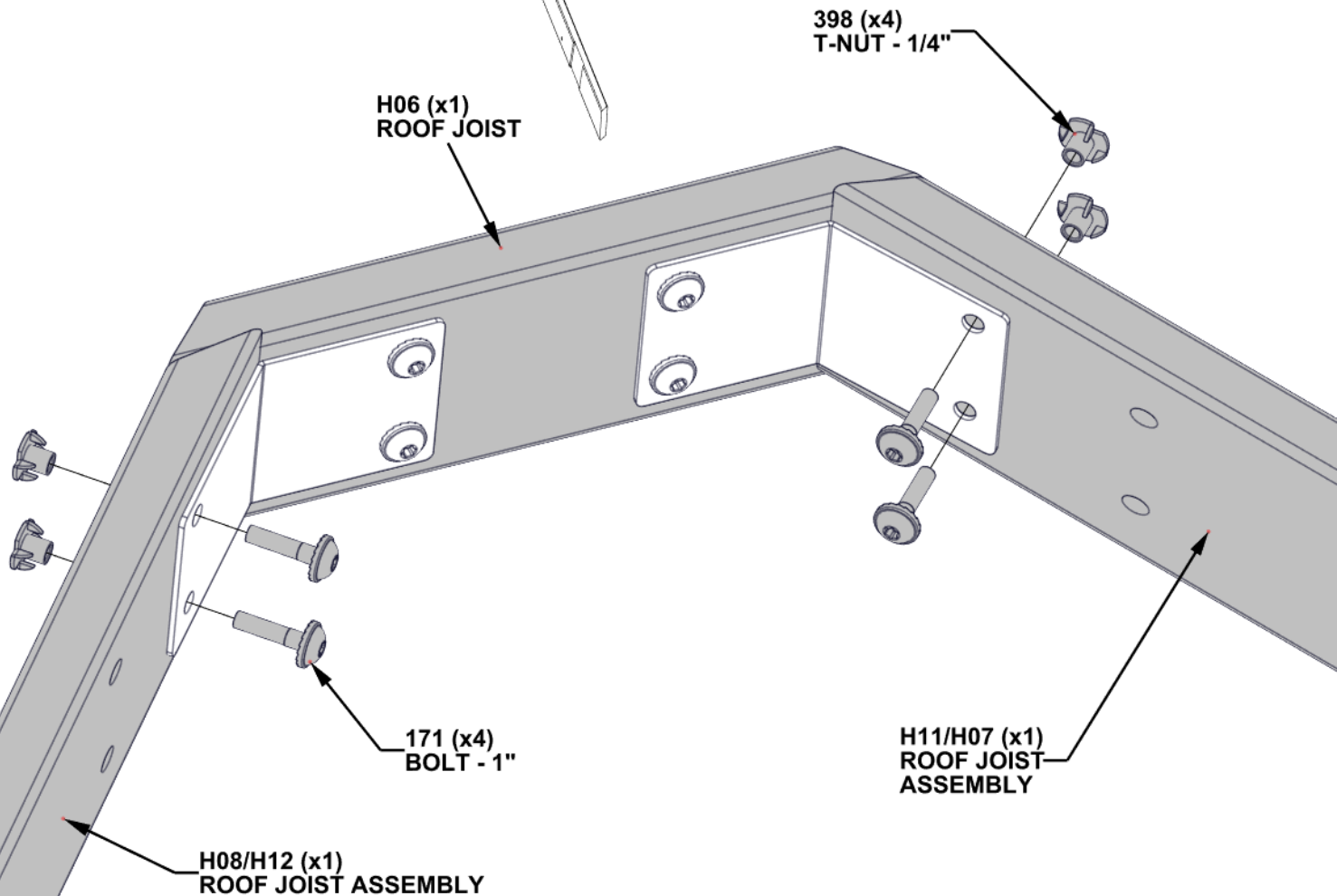
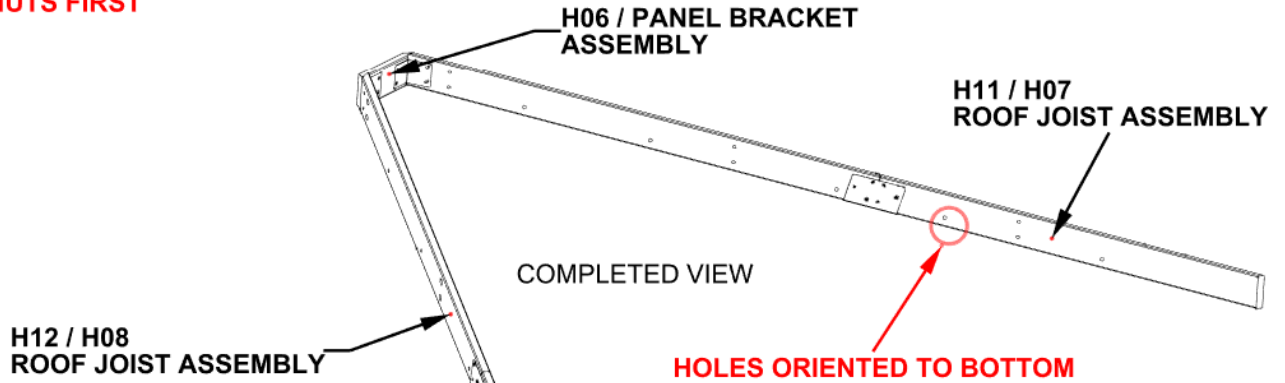

STEP 33 - FRONT / BACK ROOF PANEL ASSEMBLY

E07 RAFTER - W4L15209
(x1) 1 3/8"x3 3/8"x22" (36x86x557)

E13 RAFTER - W4L15219
(x1) 1 7/16"x3 3/8"x21 15/16" (36x86x557)

QTY	PART NUMBER	DESCRIPTION
12	H101030	CONFIRMAT - SCREW 2"

E11 RAFTER - W4L15217
(x1) 1 7/16"x3 3/8"x69" (36x86x1752)

E12 RAFTER - W4L15218
(x1) 1 7/16"x3 3/8"x45 7/16" (36x86x1155)

E05 RAFTER - W4L15207
(x1) 1 7/16"x3 3/8"x69" (36x86x1752)

E06 RAFTER - W4L15208
(x1) 1 7/16"x3 3/8"x45 7/16" (36x86x1155)

NOTE PILOT HOLES ARE FACE UP ON ALL RAFTERS

1030 (x12)
CONFIRMAT SCREW - 2"

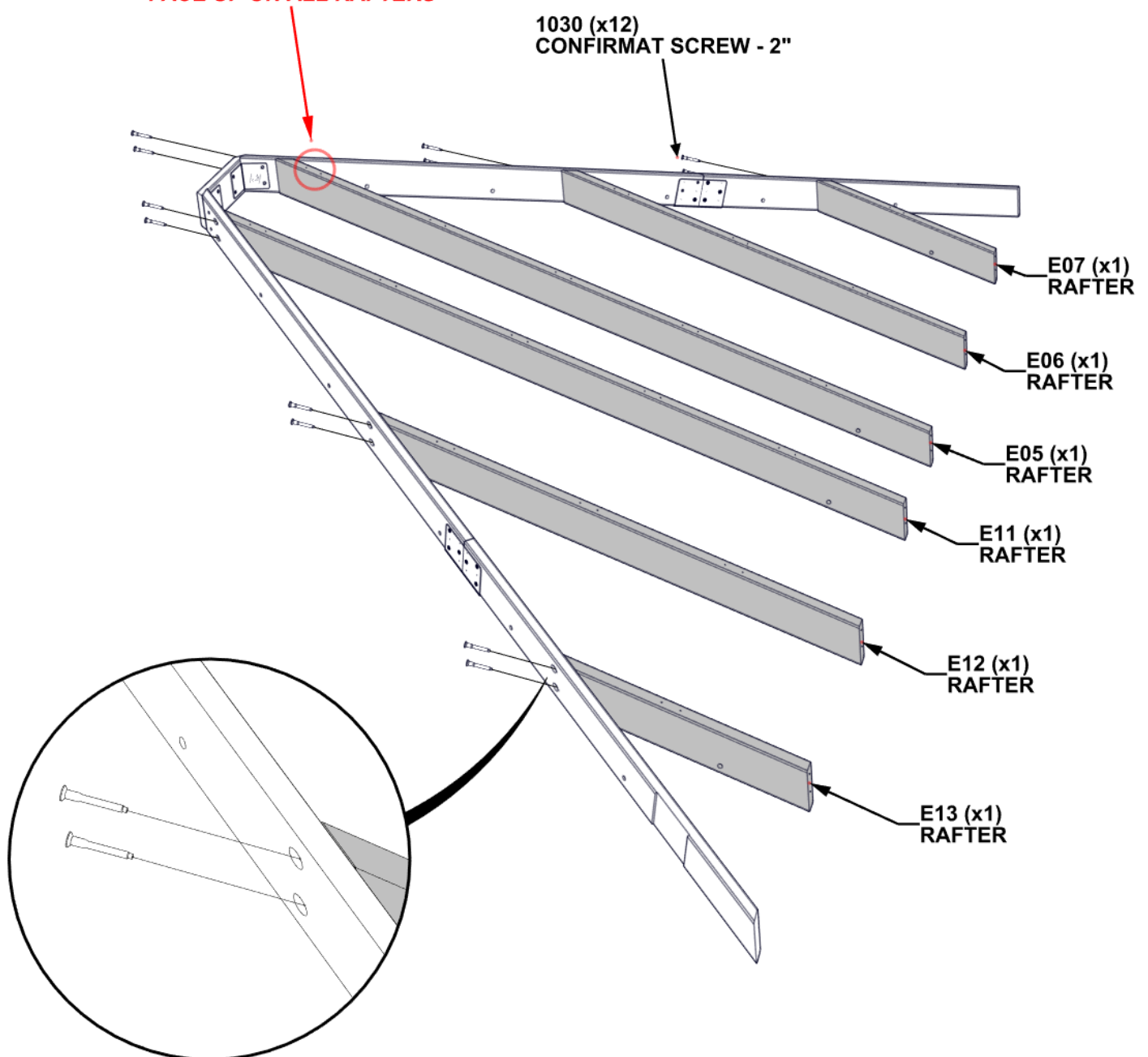

STEP 34 - FRONT / BACK ROOF PANEL ASSEMBLY



Q03 ROOF JOIST - W4L15221
(x1)

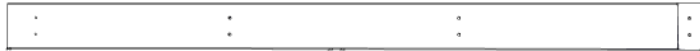

Q01 ROOF JOIST - W4L15204
(x1)

QTY	PART NUMBER	DESCRIPTION
4	H100382	SCREW PFH 8x1 3/4 BLK
12	H101030	CONFIRMAT - SCREW 2"

- USE Q01/Q03 BOARDS AS GUIDES, & A 1/8" DRILL BIT, DRILL PILOT HOLES INTO H12/11 BOARDS
- RAFTERS MAY NEED TO BE LOOSENED TO ATTACH Q01/Q03 BOARDS

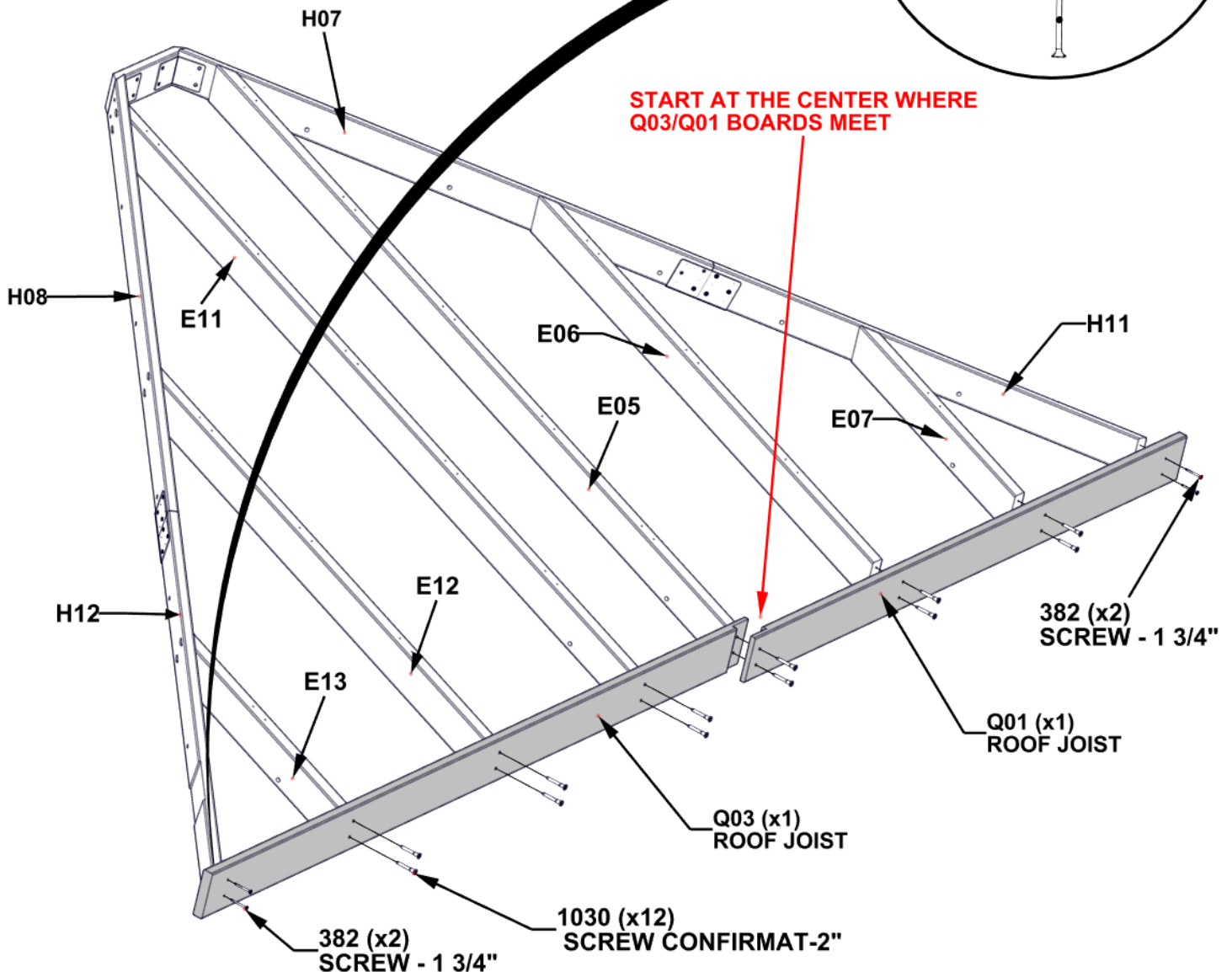
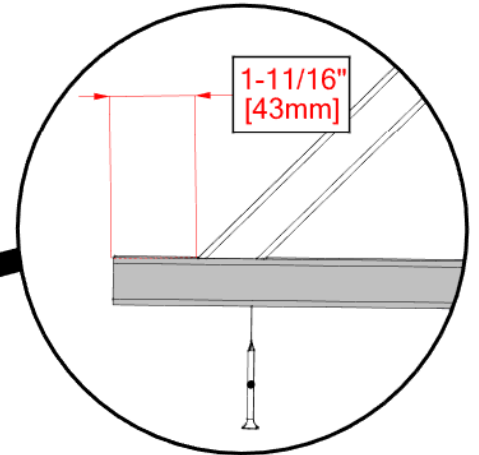

STEP 35 - FRONT / BACK ROOF PANEL ASSEMBLY

CRITICAL

- SQUARE UNIT BEFORE PROCEEDING TO NEXT STEPS.
- THE BELOW DIMENSIONS ARE CRITICAL TO THE FINAL ROOF ASSEMBLY.
- MEASUREMENTS SHOULD BE WITHIN $\pm 1/4"$.
- MEASUREMENTS OUTSIDE OF TOLERANCE WILL LEAD TO THE INABILITY TO ASSEMBLE THE ROOF

- LOOSEN HARDWARE TO ADJUST FOR SQUARING IF NEEDED

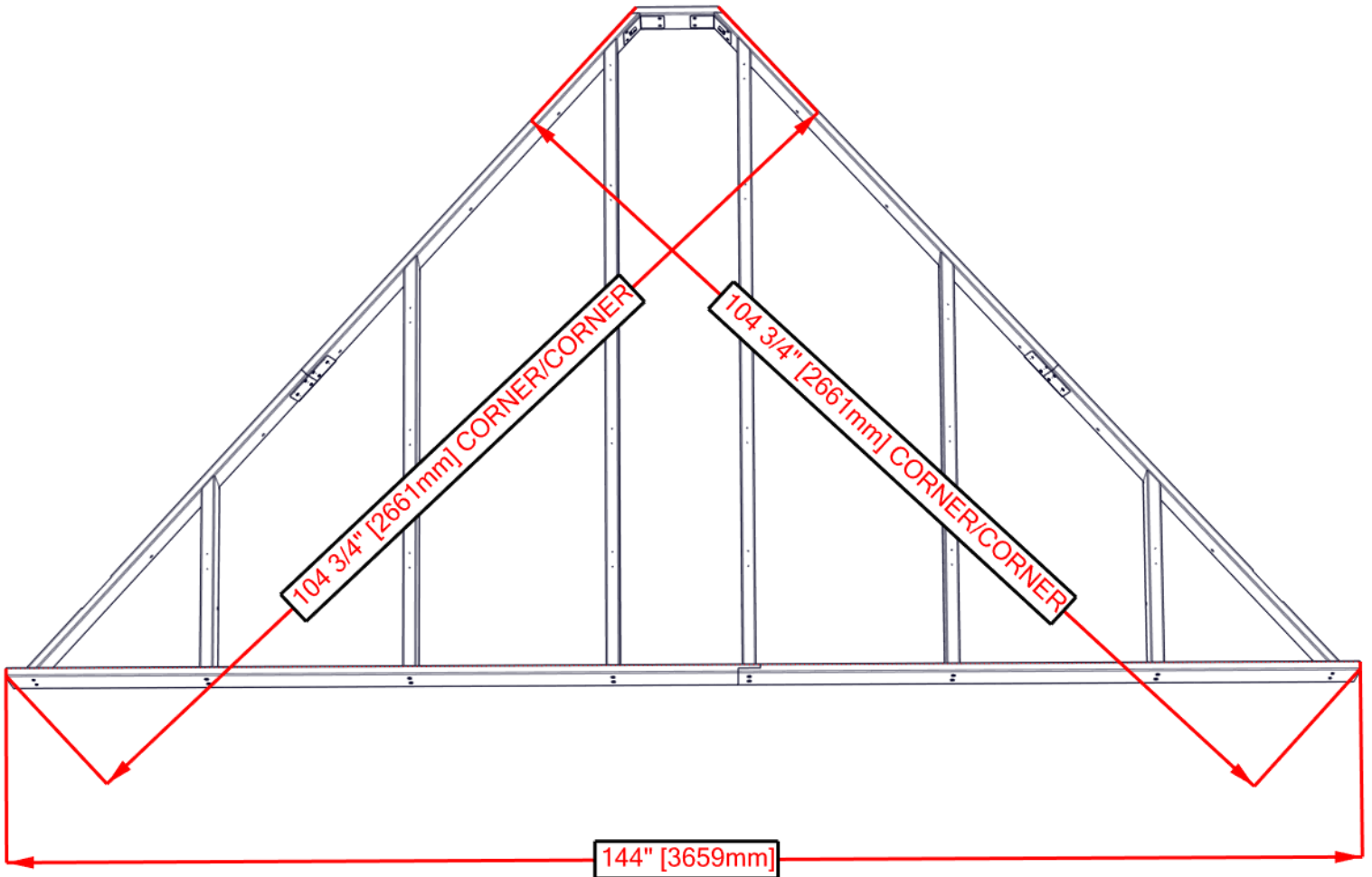

STEP 36 - FRONT / BACK ROOF PANEL ASSEMBLY

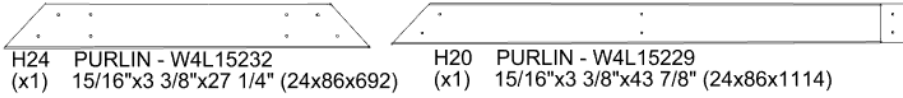

QTY	PART NUMBER	DESCRIPTION
36	H100391	SCREW PFH 8x2 BLK

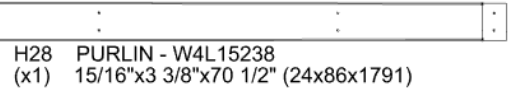
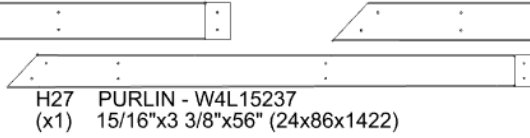
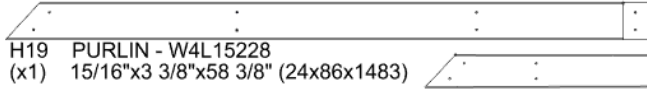
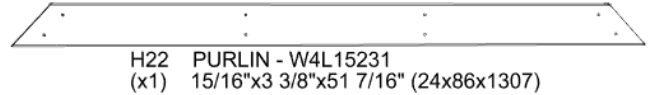
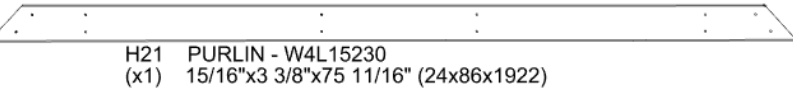

- ALIGN PURLIN PILOT HOLES WITH RAFTER PILOT HOLES
- ATTACH SCREWS FROM THE CENTER AND WORK OUTWARD

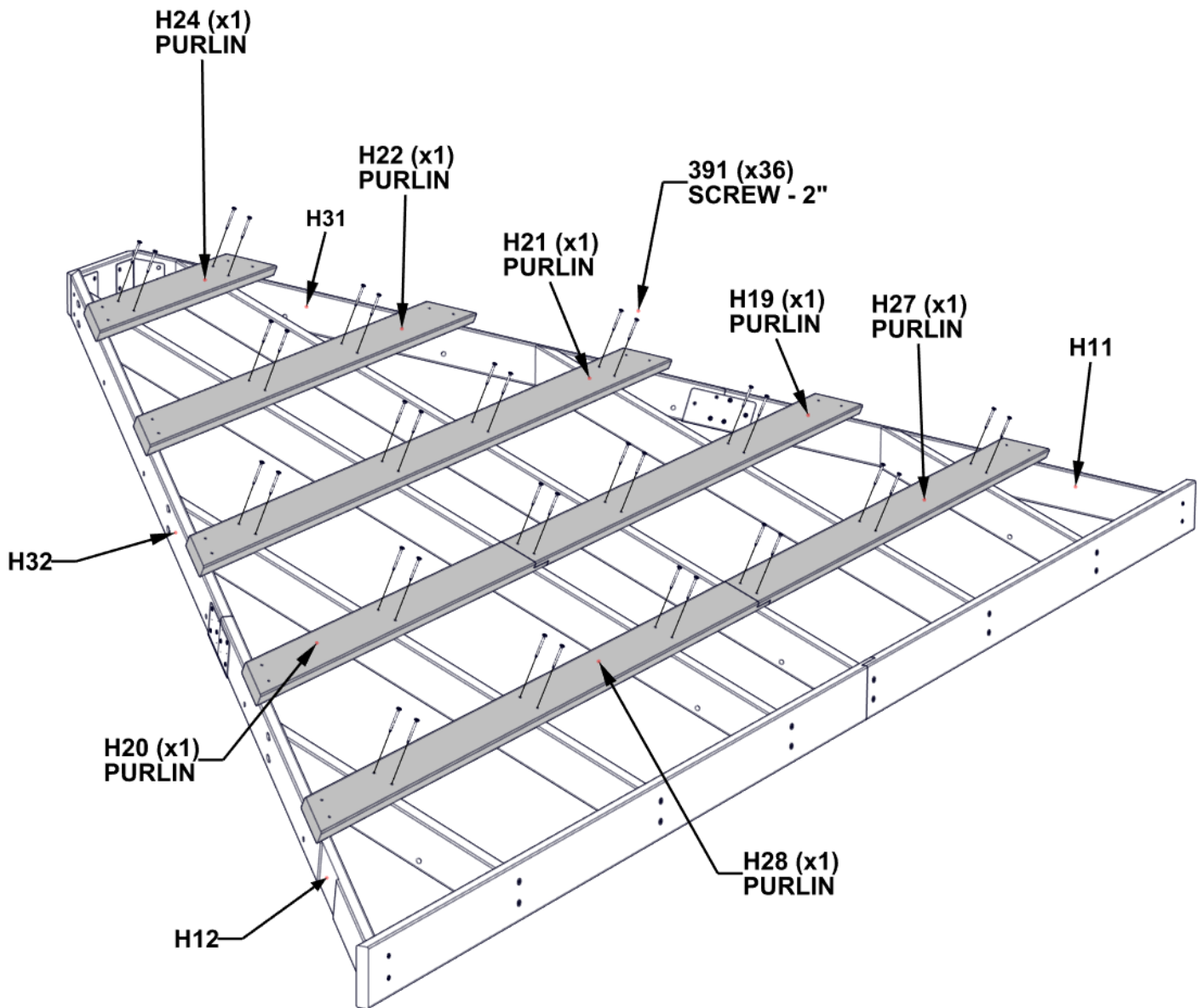

STEP 37 - FRONT / BACK ROOF PANEL ASSEMBLY



T02 PURLIN - W4L15239
 (x1) 15/16"x1 5/16"x12 7/8" (24x34x327)

QTY	PART NUMBER	DESCRIPTION
22	H100391	SCREW PFH 8x2 BLK

- H11, H12, H31, & H32 BOARDS DO NOT HAVE PILOT HOLES FOR OUTSIDE EDGE SCREWS
- USING THE PURLINS AS A GUIDE AND A 1/8" DRILL BIT, DRILL PILOT HOLES INTO H12/H08/H11/H07 BOARDS

**- IF PURLINS OVERHANG MORE THAN 5/8"
 CUT DOWN TO 5/8"**

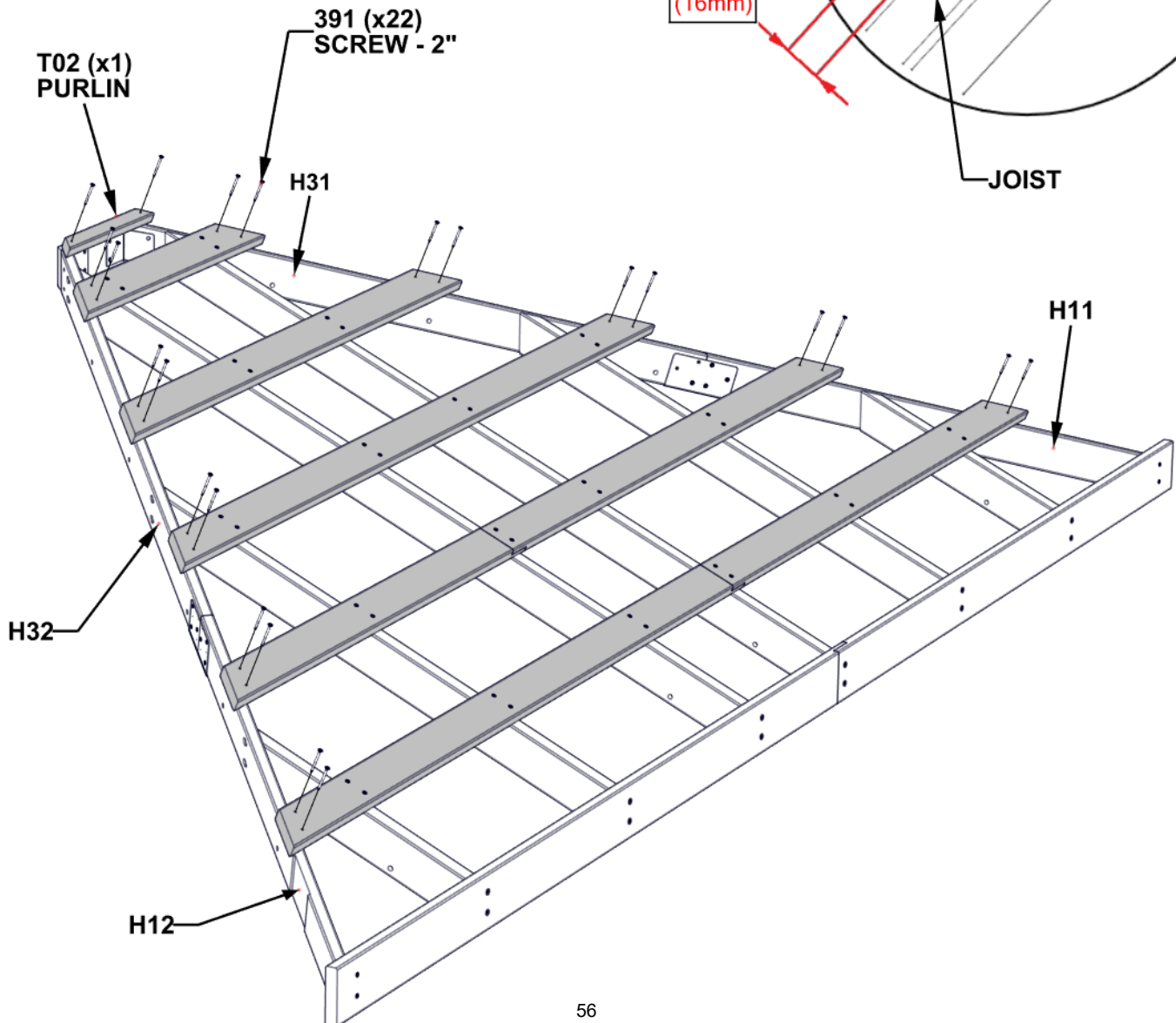
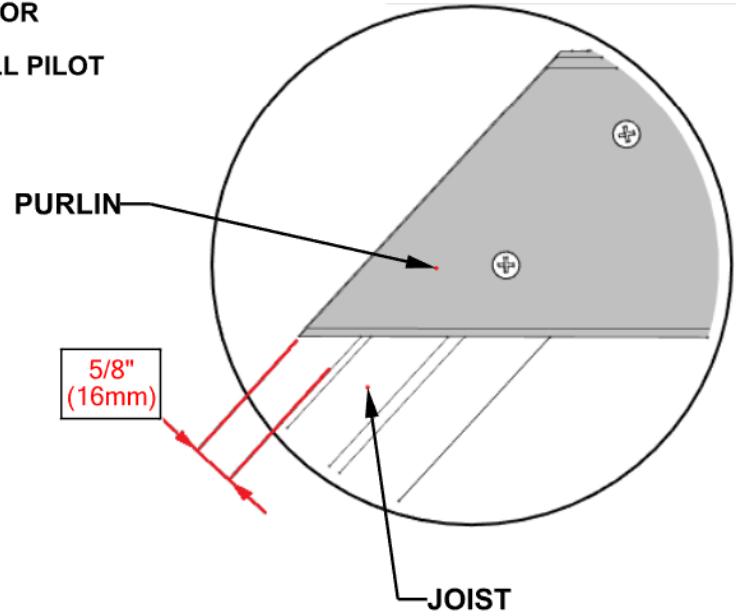

STEP 38 - FRONT / BACK ROOF PANEL ASSEMBLY

29GA STEEL SHEETING - A4M01923-1
(x1) 0.02x30 11/16"x14 1/4"

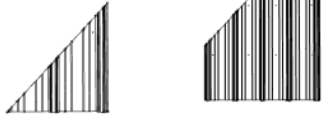

29GA STEEL SHEETING - A4M01924-2
(x1) 0.02x30 11/16"x32 15/16"



29GA STEEL SHEETING - A4M01923-2
(x1) 0.02x30 11/16"x14 1/4"



29GA STEEL SHEETING - A4M01922-2
(x1) 0.02x30 11/16"x45 5/16"



29GA STEEL SHEETING - A4M01922-1
(x1) 0.02x30 11/16"x45 5/16"

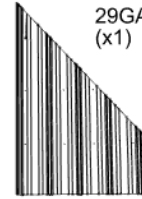

29GA STEEL SHEETING - A4M01924-1
(x1) 0.02x30 11/16"x32 15/16"



- REMOVE PROTECTIVE BLUE FILM. THIS SIDE WILL FACE UP.
- STARTING IN THE CENTER, PLACE PANELS AS SHOWN BELOW.
- OVERLAP PANELS BY ONE RIDGE.
- PANELS SHOULD BE FLUSH WITH PURLIN ENDS AND ROOF JOIST.

WARNING: GLOVES ARE RECOMMENDED WHEN HANDLING STEEL ROOF SHEETING

SHEETING EXTENDS BEYOND FRAME

SHEETING FLUSH WITH PURLIN END & JOIST FRONT

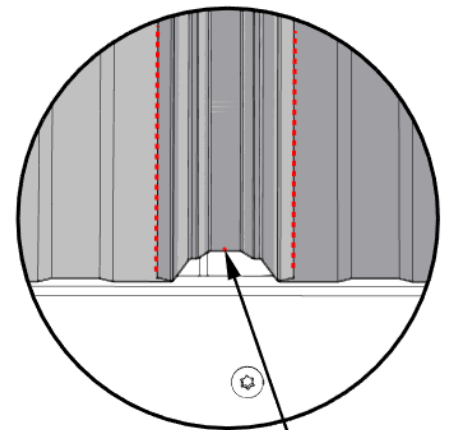
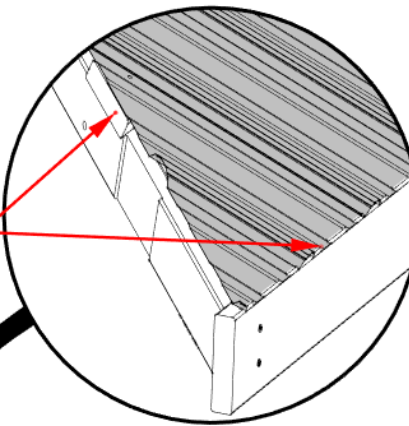

OVERLAP SHEETING BY 1 RIDGE

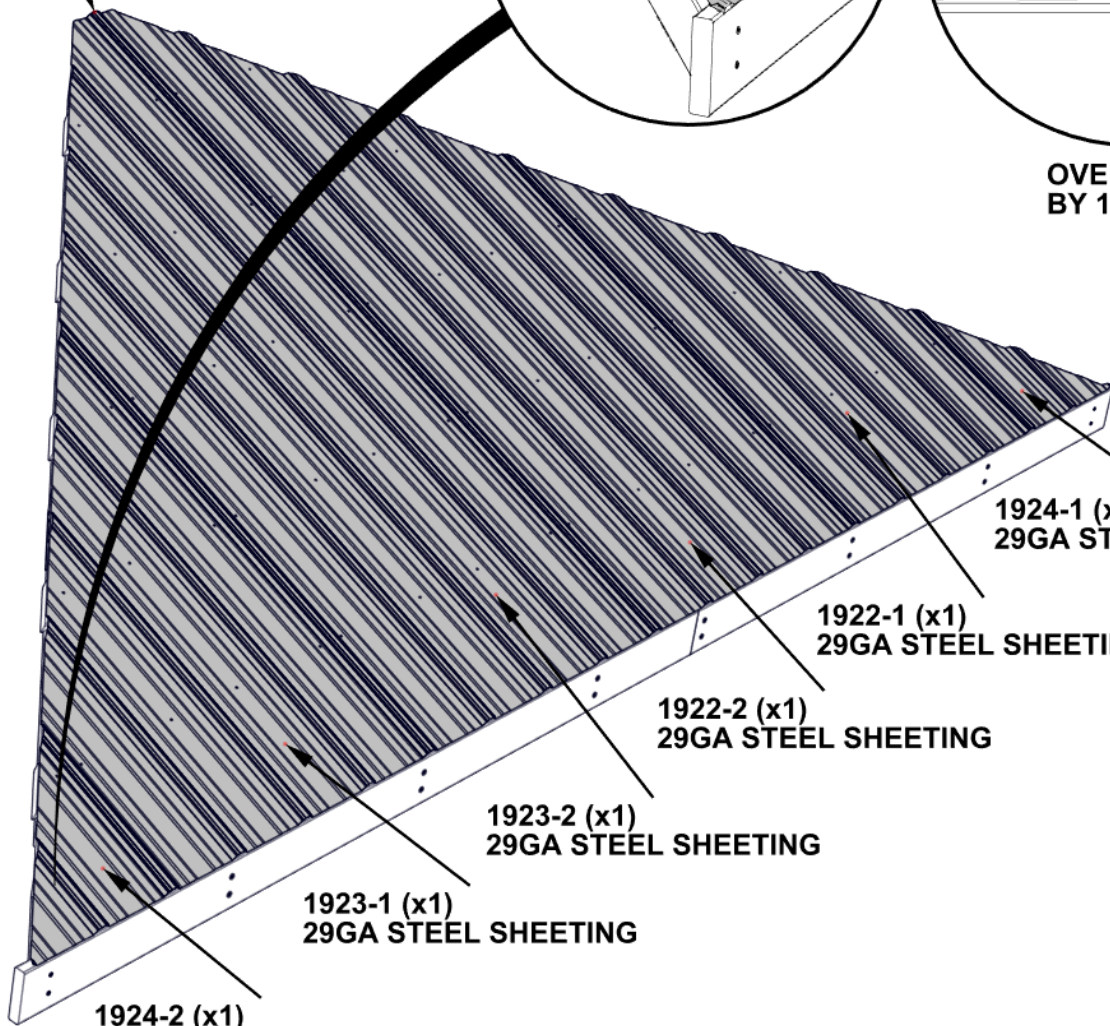

1924-1 (x1)
29GA STEEL SHEETING

1922-1 (x1)
29GA STEEL SHEETING

1922-2 (x1)
29GA STEEL SHEETING

1923-2 (x1)
29GA STEEL SHEETING

1923-1 (x1)
29GA STEEL SHEETING

1924-2 (x1)
29GA STEEL SHEETING

STEP 39 - FRONT / BACK ROOF PANEL ASSEMBLY

QTY	PART NUMBER	DESCRIPTION
46	H100833	SCREW WOODGRIP 10-16x3/4

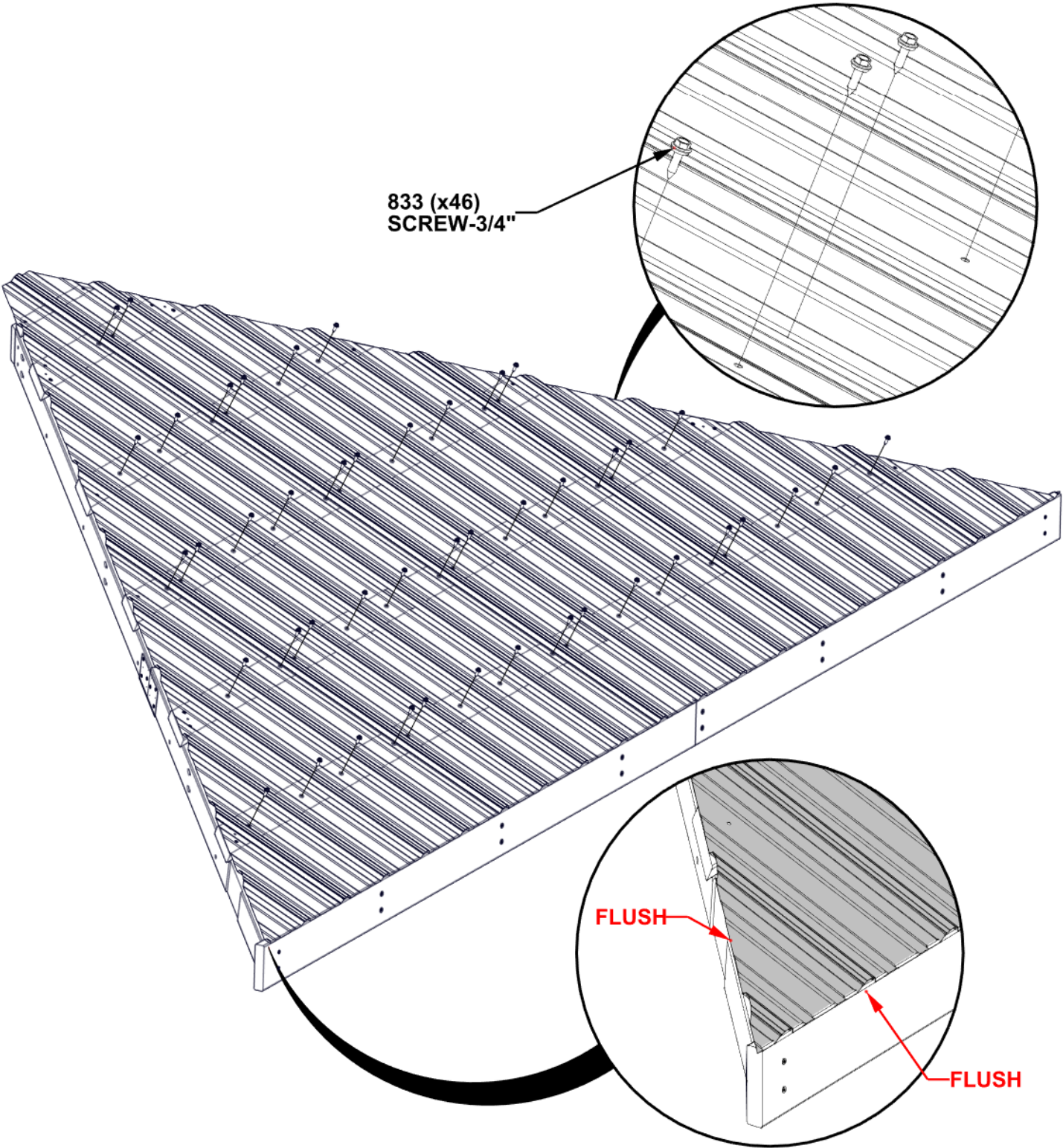

STEP 40 - FRONT / BACK ROOF PANEL ASSEMBLY

QTY	PART NUMBER	DESCRIPTION
6	H100833	SCREW WOODGRIP 10-16x3/4"

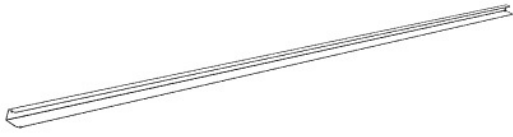

A4M02847 - RIDGE CAP CHANNEL LONG (x2)

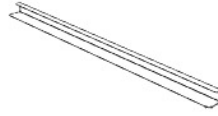

A4M02850 - RIDGE CAP CHANNEL SHORT (x2)

- POSITION THE RIDGE CAP CHANNEL OVER THE EDGE OF THE ROOF PANELS WITH THE WIDER SIDE OF THE CHANNEL ON THE BOTTOM.
- MAKE SURE THE PANELS ARE FULLY SEATED INTO THE CHANNEL.
- FLUSH THE TOP OF THE CHANNEL WITH THE TOP OF THE METAL PANELS.

833 (x6)
SCREW WOODGRIP 10-16x3/4"

PURLIN UNDERNEATH
TIN SHEETING

2847 (x2)
RIDGE CAP CHANNEL LONG

FLUSH

2850 (x2)
RIDGE CAP CHANNEL SHORT

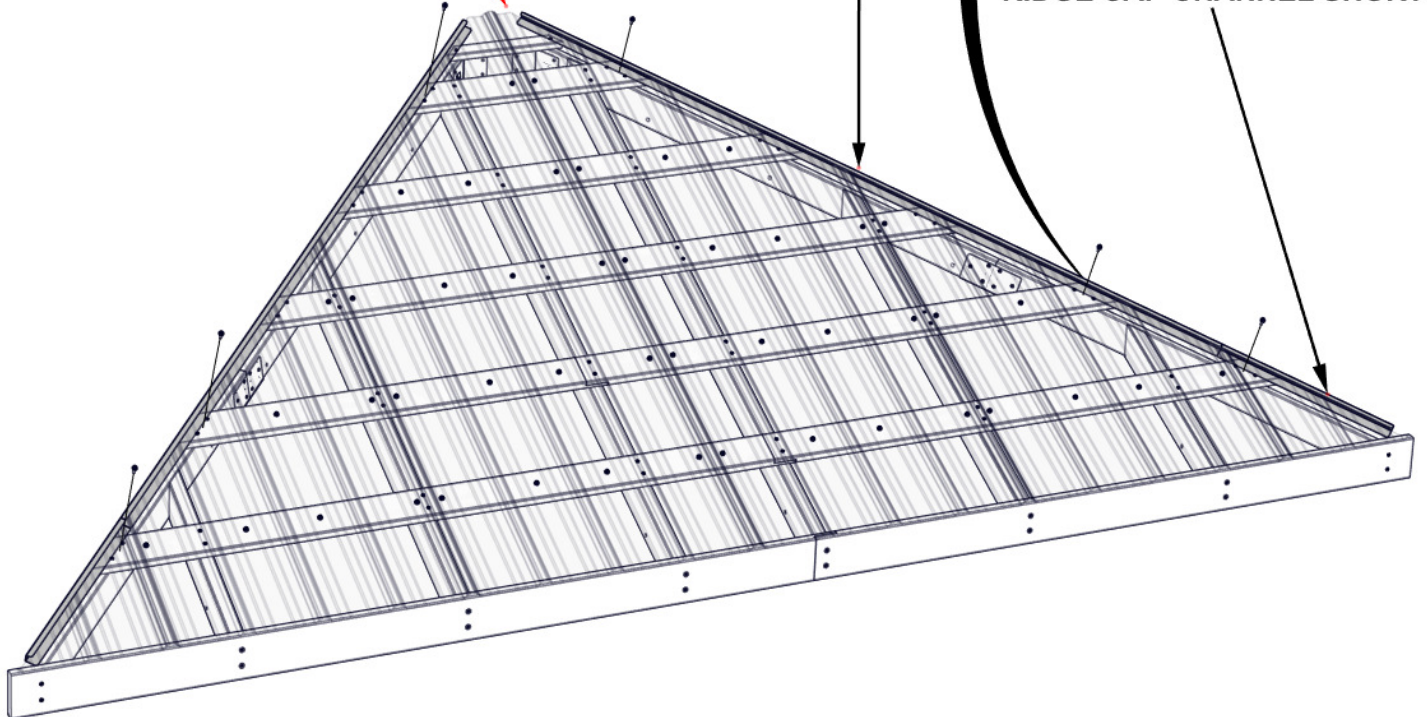
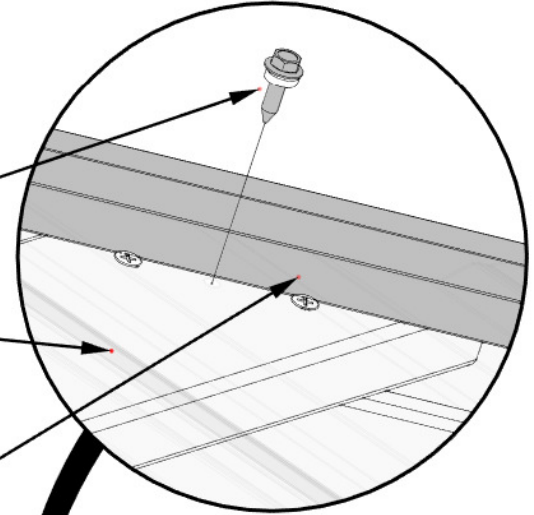

**REPEAT FRONT/BACK ROOF
PANEL ASSEMBLY STEPS 30
THROUGH 40**

STEP 41 - ROOF PANEL ATTACHMENT

- 3 PEOPLE ARE RECOMMENDED FOR THIS STEP.
- POSITION A PERSON ON A LADDER IN THE CENTER OF THE GAZEBO TO HELP SUPPORT THE ROOF PANEL.
- WITH 2 PEOPLE, WORK THE PANEL UP WITHOUT SLIDING OR DRAGGING, UNTIL IT MEETS THE ROOF SUPPORT FRAME.
- MAKE SURE THE ROOF PANEL SLIDES UNDERNEATH THE RIDGE CAP.

SEE NEXT STEP FOR ROOF PANEL HARDWARE ATTACHMENT

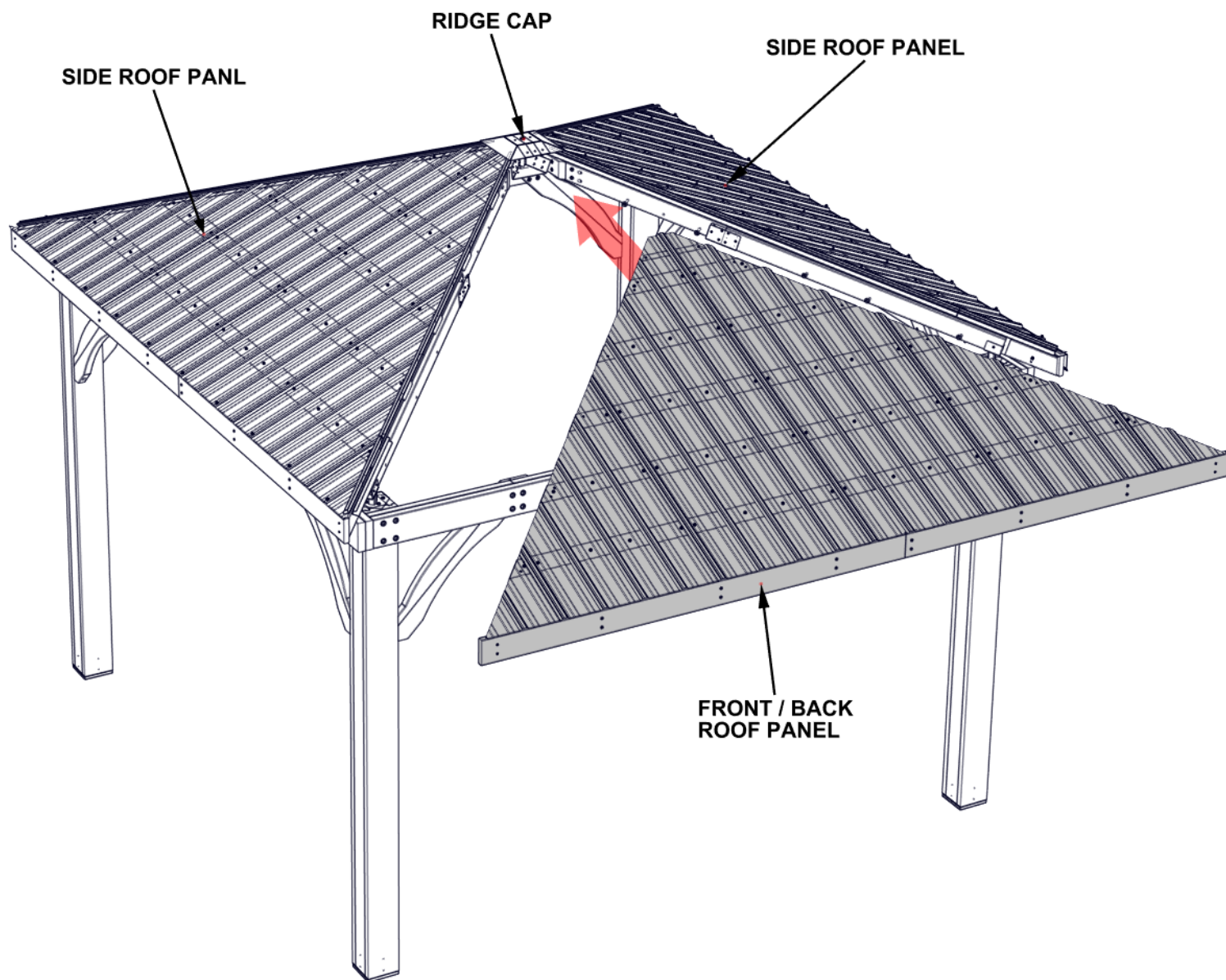

STEP 42 - ROOF PANEL ATTACHMENT

QTY	PART NUMBER	DESCRIPTION
20	H100198	WASHER LOCK EXT 8x19
20	H100415	BOLT WH 5/16x3 3/4 BLK
20	H100479	NUT LOCK 5/16 BLK
20	H100770	WASHER FLAT 5/16 BLK

- HAND TIGHTEN ONLY
- REPEAT ON ALL PANEL EDGES

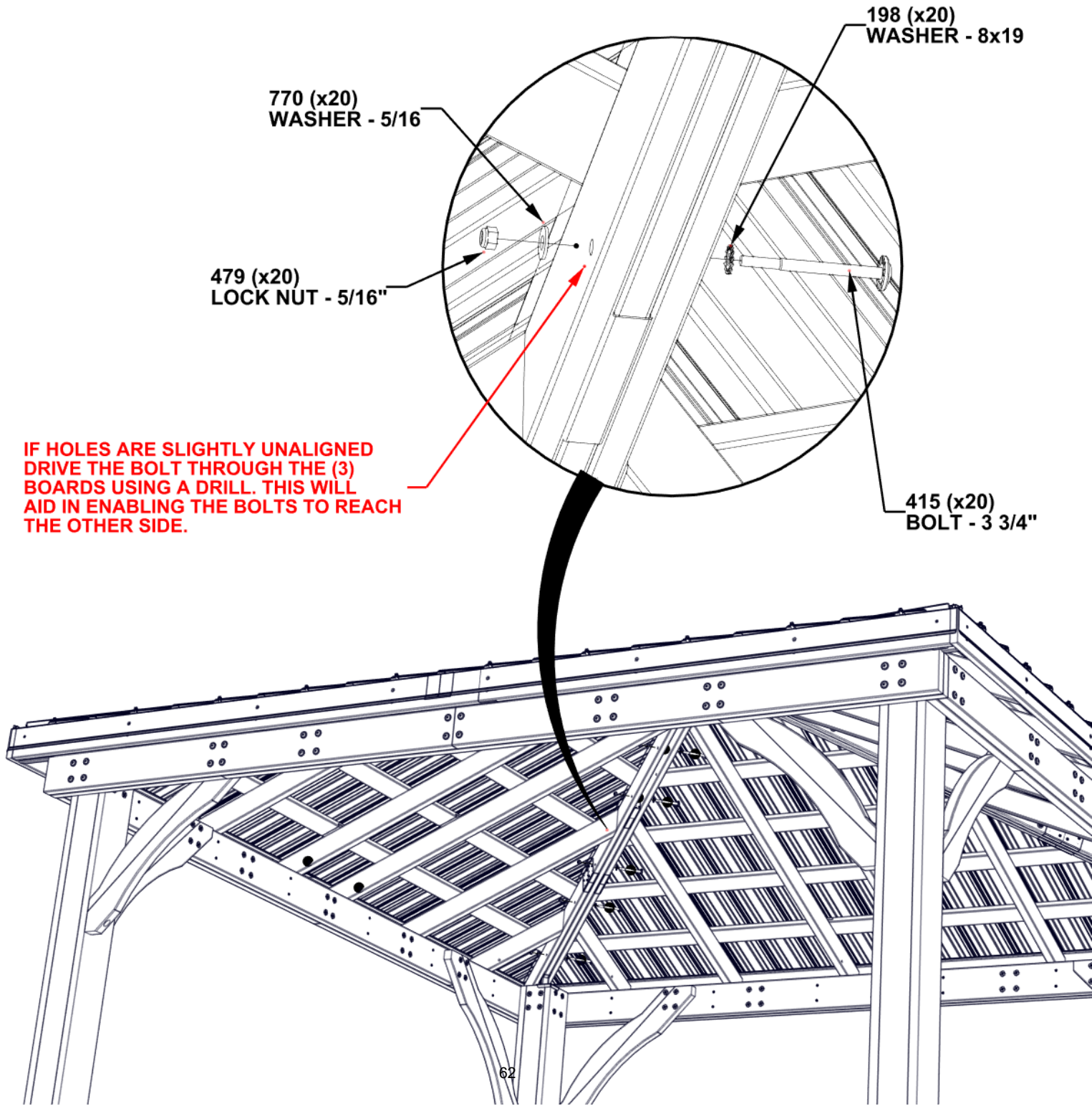

IF HOLES ARE SLIGHTLY UNALIGNED
DRIVE THE BOLT THROUGH THE (3)
BOARDS USING A DRILL. THIS WILL
AID IN ENABLING THE BOLTS TO REACH
THE OTHER SIDE.

STEP 43 - ROOF PANEL ASSEMBLY

**TIGHTEN ALL THE HARDWARE IN THE ORDER SHOWN BELOW.
START AT THE TOP AND WORK YOUR WAY DOWN.**

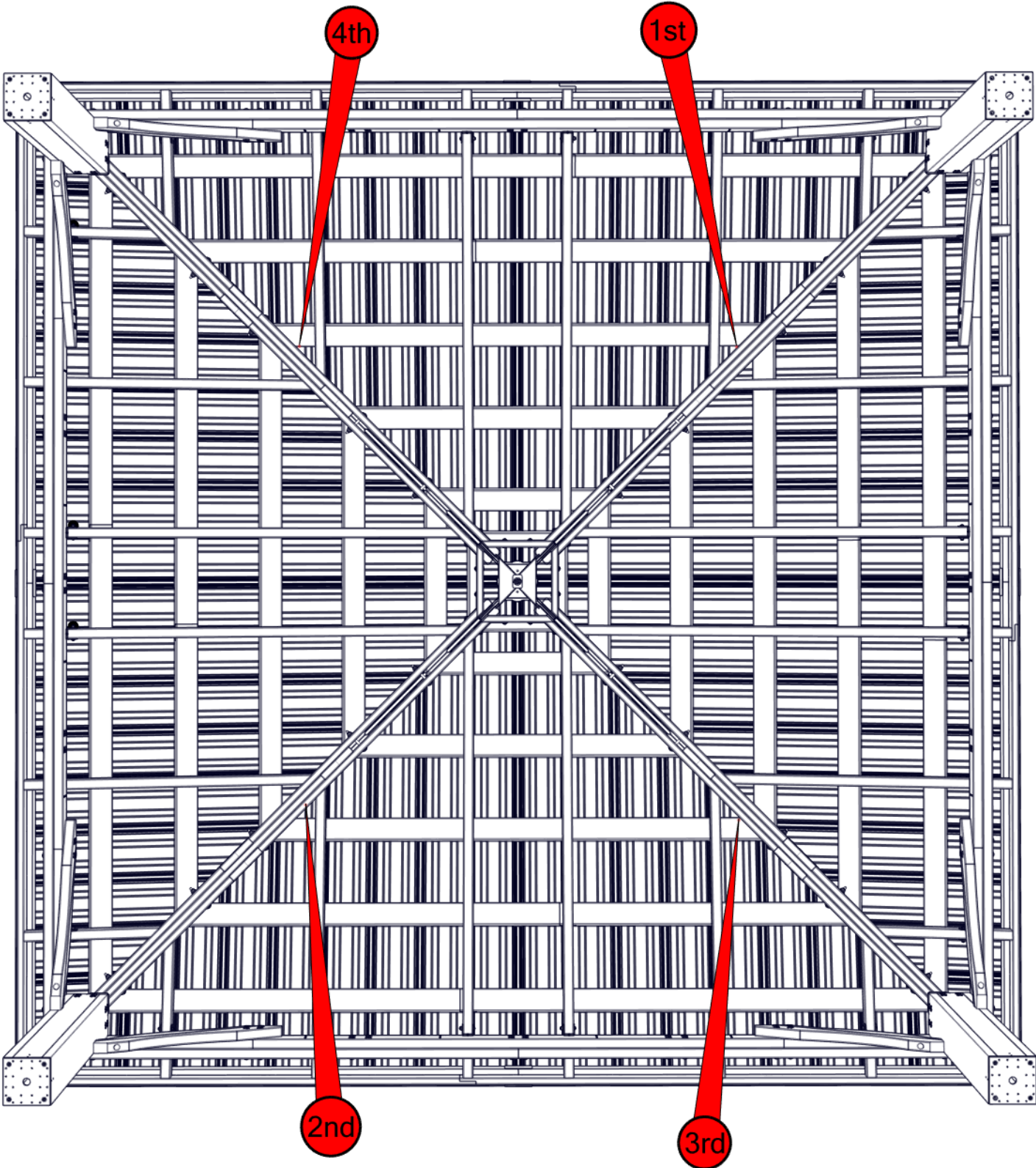

STEP 44 - ROOF TRIM ASSEMBLY

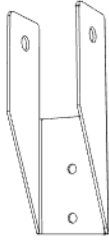

A4M01228 - RAFTER CLIP-
(x16)

QTY	PART NUMBER	DESCRIPTION
16	H100488	BOLT WH 1/4x2 BLK
32	H100536	SCREW PWH 8x1 1/4 BLK
16	H100630	WASHER FLAT 8x19 BLK
16	H100653	NUT LOCK 1/4 BLK

- ATTACH RAFTER CLIPS FIRST WITH 2" BOLTS
- USING THE BRACKET AS A TEMPLATE & A 1/8" DRILL BIT, DRILL PILOT HOLES FOR THE H100536 SCREWS.
- DRILL PILOT HOLES APPROXIMATELY 1/2" DEEP.

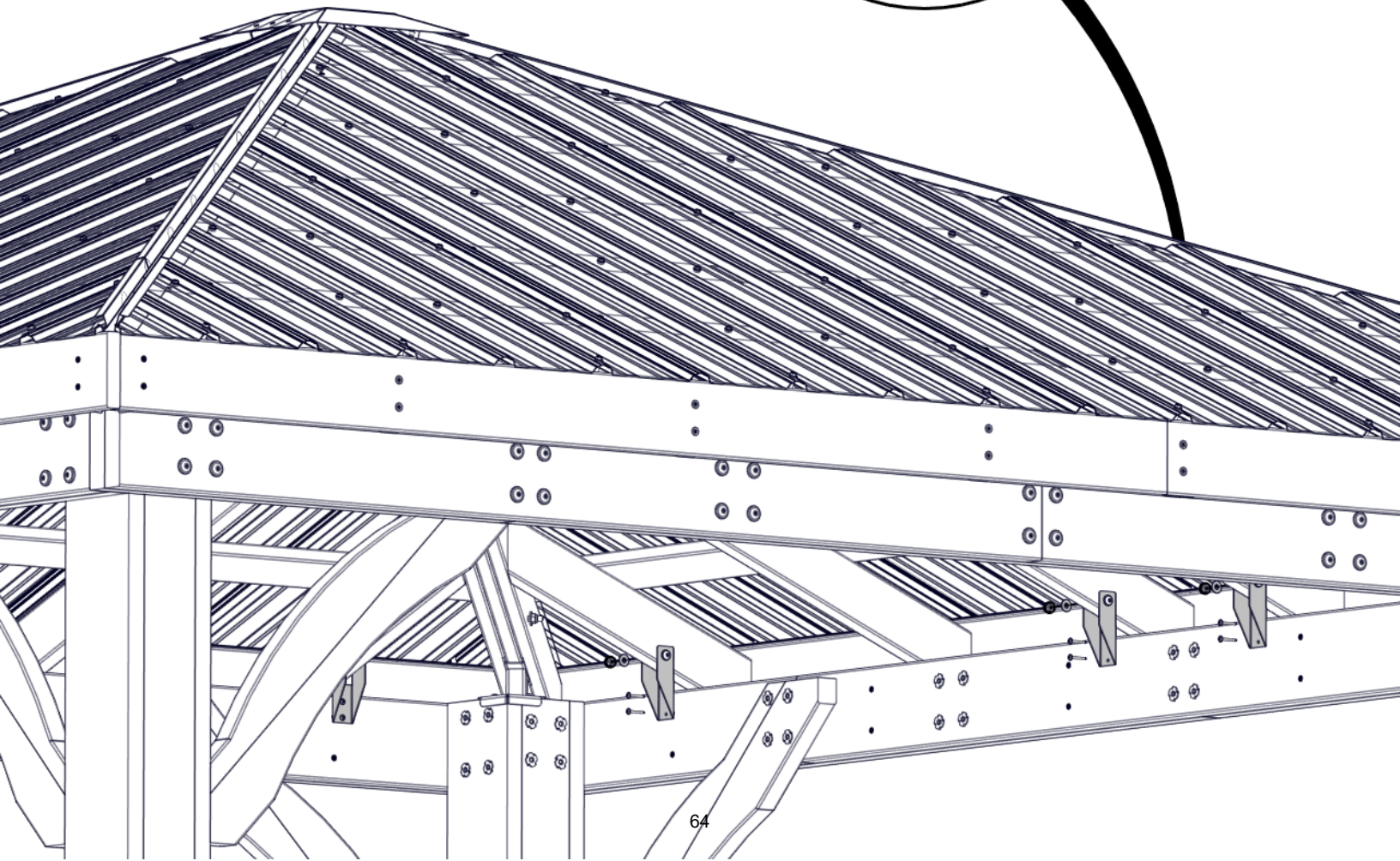
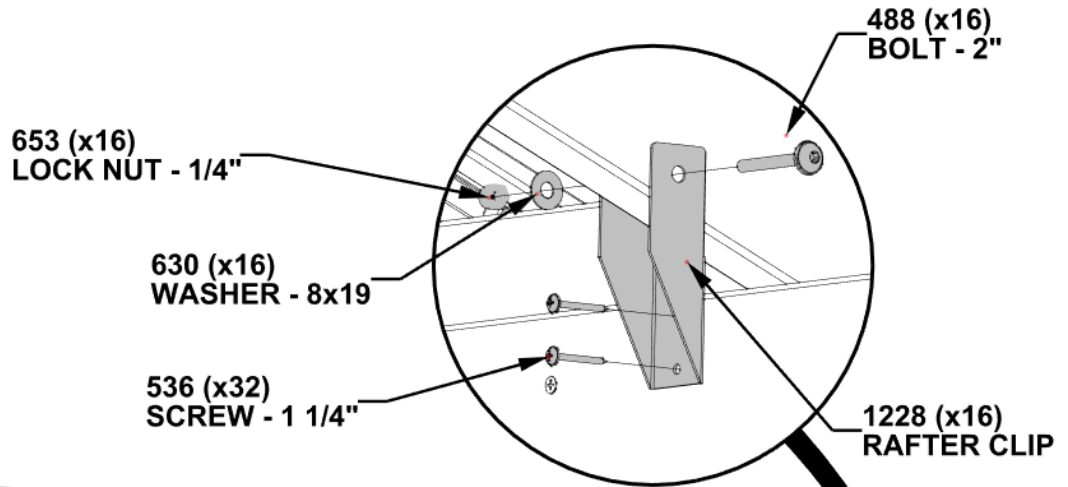

STEP 45 - ROOF TRIM ASSEMBLY



A4M01185 - CORNER BRACKET
(x4)

QTY	PART NUMBER	DESCRIPTION
16	H100392	SCREW PWH 8x3/4 BLK

- USING THE CORNER BRACKETS AS A GUIDE & A 1/8" DRILL BIT, PREDRILL HOLES AT EACH BRACKET LOCATION

- REPEAT THIS STEP ON THE 3 REMAINING CORNERS

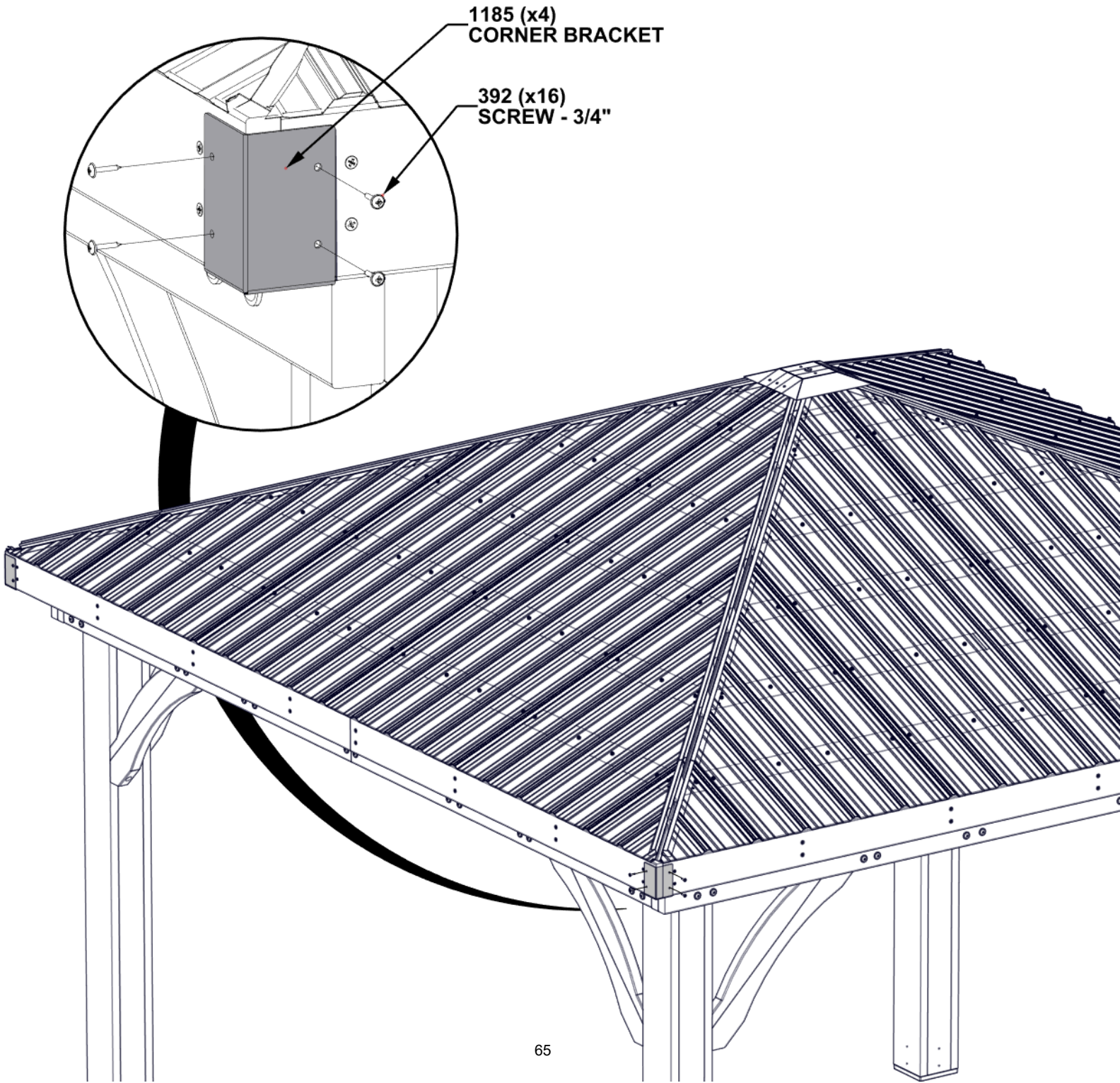

STEP 46 - DRIP EDGE ASSEMBLY

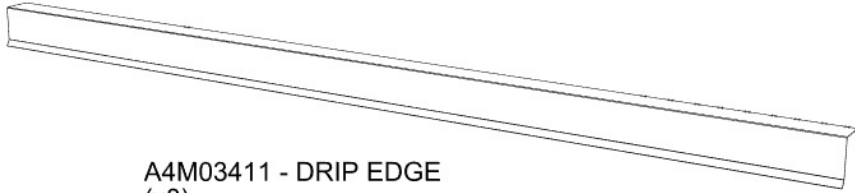

A4M03411 - DRIP EDGE
(x8)

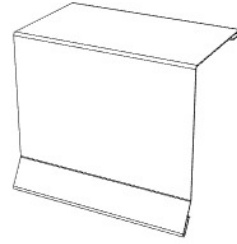

A4M03410 - DRIP EDGE SPLICE
(x4)

- INSERT 1 DRIP EDGE INTO EACH SIDE OF THE SPLICE SO THEY MEET IN THE CENTER.
- INSERT THE DRIP EDGE ASSEMBLY UNDER THE ROOF SHEETING, AND ON TOP OF THE ROOF JOIST.
- SEE THE DETAIL BELOW

- REPEAT THIS STEP FOR ALL 4 SIDES

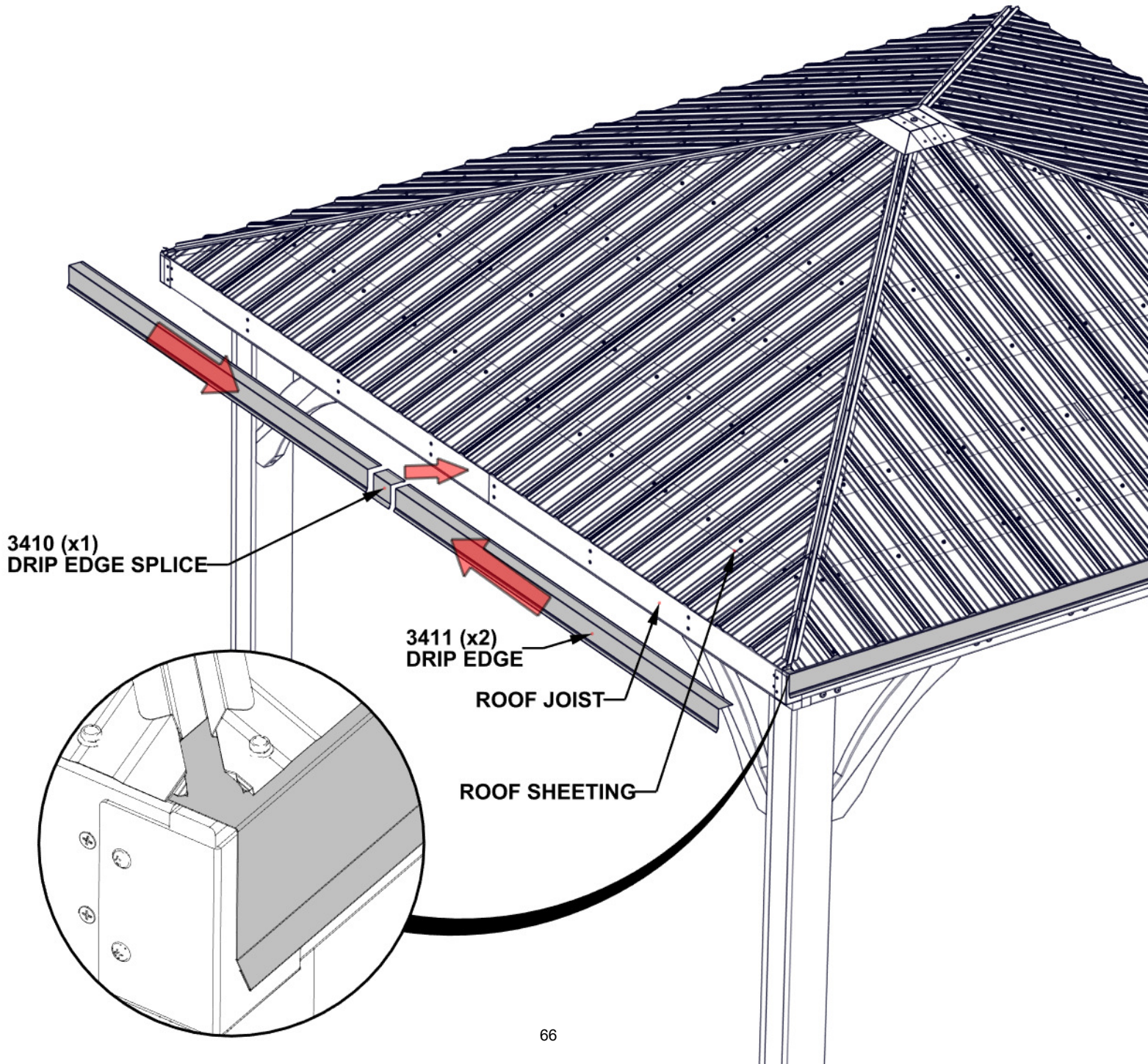

STEP 47 - ROOF TRIM ASSEMBLY

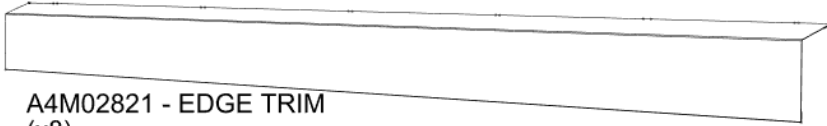

A4M02821 - EDGE TRIM
(x8)

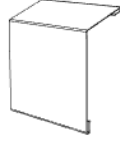
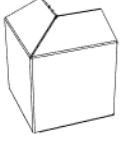

QTY	PART NUMBER	DESCRIPTION
40	H100759	SCREW SELF TAPPING 1/4x1

A4M02825 - EDGE TRIM CORNER SPLICE -
(x4)

A4M02822 - EDGE TRIM SPLICE -
(x4)

- SLIDE EDGE TRIM PIECES INTO EACH SIDE OF THE EDGE TRIM SPLICE AND CORNER SPLICE.
- CENTER THE EDGE TRIM ASSEMBLY OVER THE EDGE OF THE ROOF.
- BE SURE ALL ROOF PANELS ARE COVERED BEFORE INSTALLING SCREWS.
- START SCREWS AT THE FIRST HIGH RIDGE OF THE ROOF SHEETING.
- BE SURE TO INSERT SCREWS THROUGH TRIM PIECES AND DRIP EDGE PIECES.
- PROCEED TO INSTALL A SCREW AT EVERY OTHER HIGH RIDGE (10 PER SIDE).

REPEAT THIS STEP ON ALL 4 SIDES

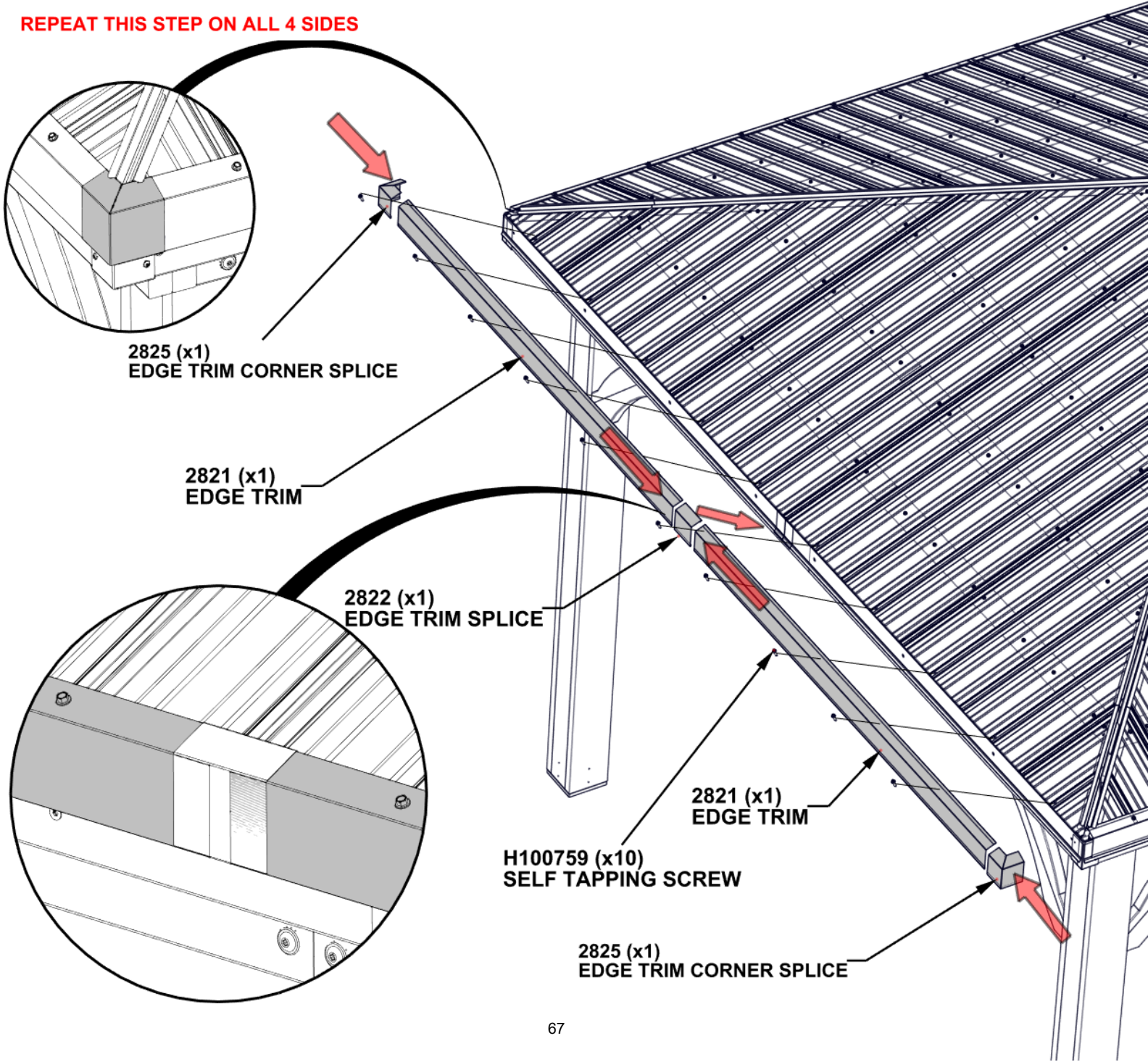

STEP 48 - ROOF ASSEMBLY

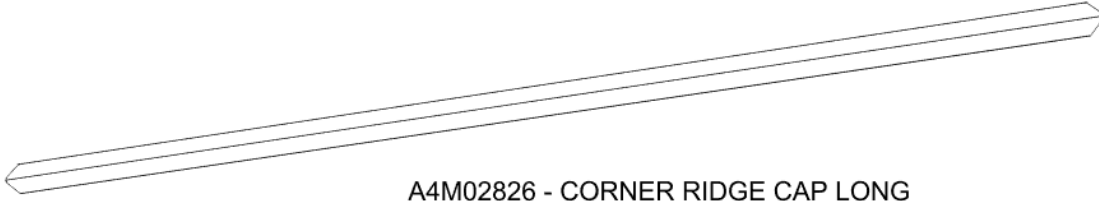

A4M02826 - CORNER RIDGE CAP LONG
(x4)

- SLIDE LONG CORNER RIDGE CAP ONTO ROOF RIDE CAP CHANNEL AS SHOWN.
- SLIDE THE END UNDER THE PEAK RIDGE CAP PLATE.
- THIS PIECE WILL BE SECURED INTO PLACE DURING THE NEXT STEP.
- IF NEEDED, THE PEAK RIDGE CAP CAN BE LOOSENED WITH THE EYE NUT TO MAKE ROOM FOR 248 RIDGE CAP.

REPEAT THIS STEP FOR ALL 4 CORNERS

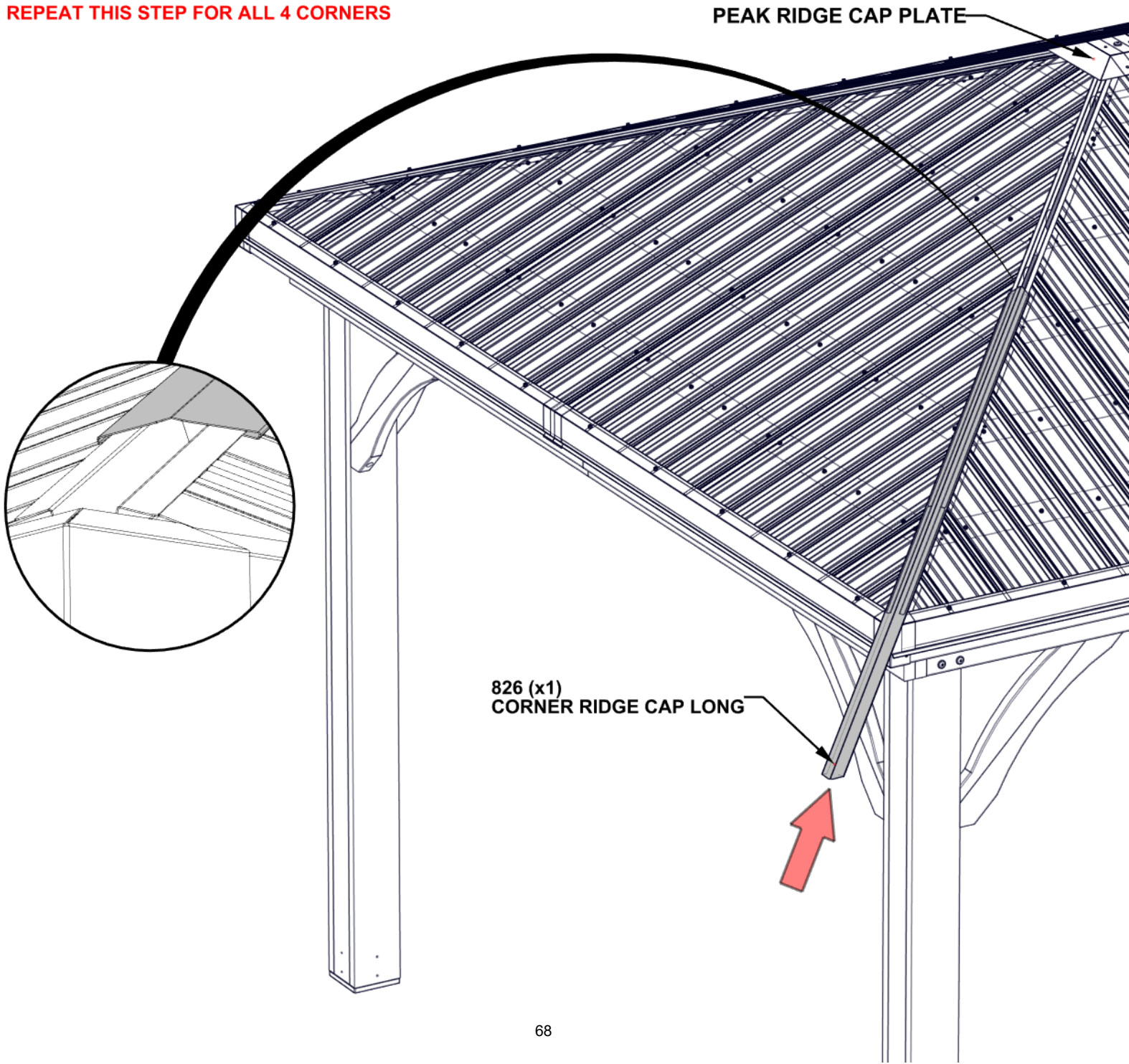

STEP 49 - ROOF ASSEMBLY



CORNER RIDGE CAP SHORT - A4M02867
(x4)

QTY	PART NUMBER	DESCRIPTION
12	H100759	SCREW SELF TAPPING 1/4x1

- SLIDE CORNER RIDGE CAP ONTO THE ROOF RIDGE CAP CHANNEL SAME AS (PREVIOUS STEP 48).
- SLIDE THE SHORT RIDGE CAP SPLICE OVER THE END OF THE LONG RIDGE CAP.
- SECURE THE CORNER RIDGE CAP WITH 2 SCREWS AS SHOWN.
- SECURE THE RIDGE CAP SPLICE WITH 1 SCREW THROUGH SPLICE AND LONG RIDGE CAP.

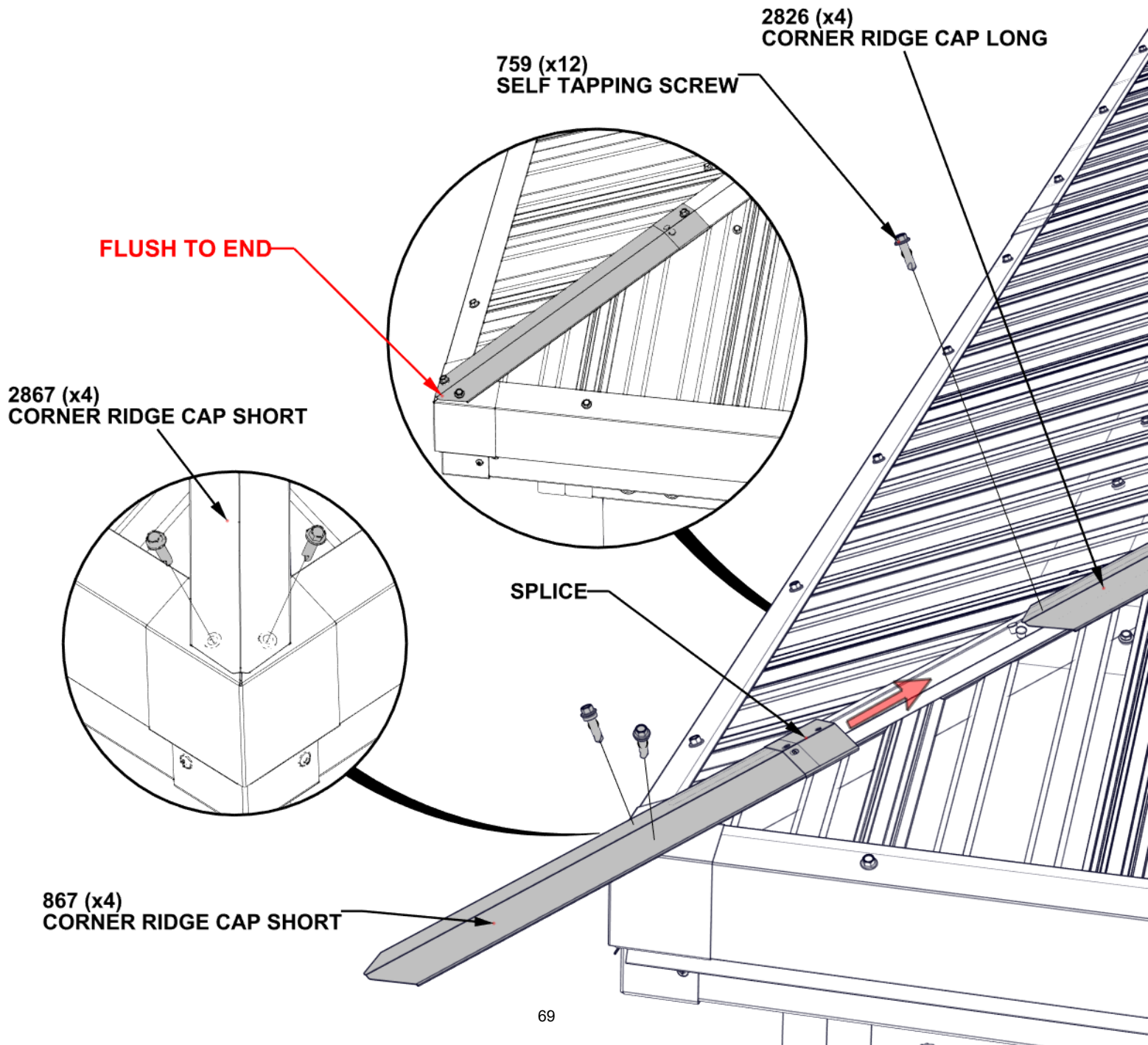

STEP 50 - ANCHORING HARDWARE

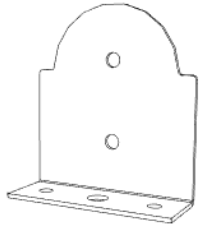

A4M01793 - POST ANCHORING PLATE
(x8)

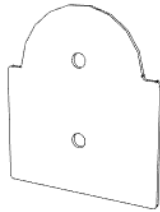

A4M01794 - POST PLATE
(x8)

QTY	PART NUMBER	DESCRIPTION
32	H100471	LAG SCREW WH 5/16x1 1/2 BLK

- ALIGN PLATE HOLES WITH POST PILOT HOLES
- ALL POST PLATES GO ON THE INSIDES OF THE POSTS AS SHOWN
- ALL POST ANCHORING PLATES GO ON THE OUTSIDE OF THE POSTS AS SHOWN

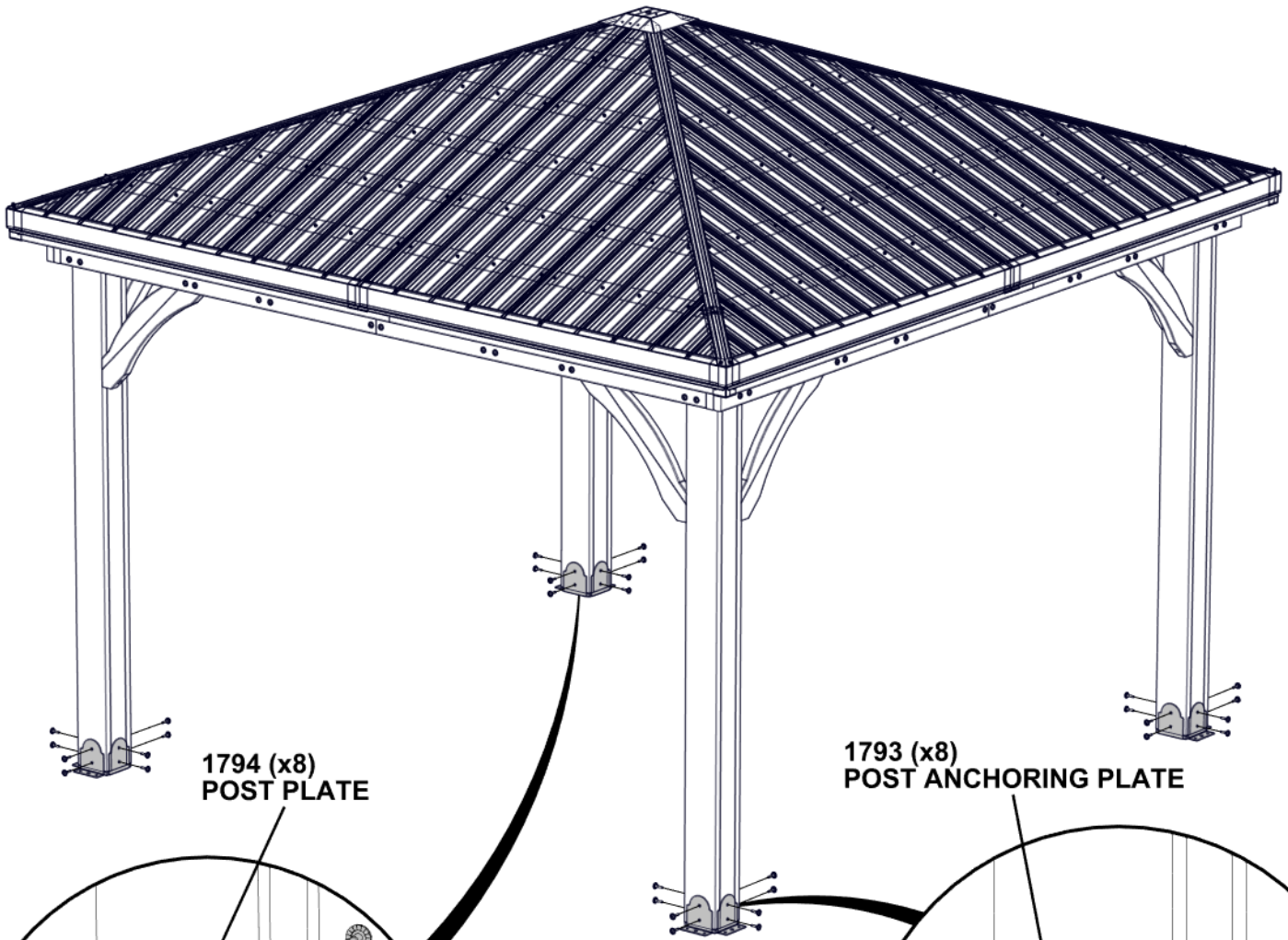

1794 (x8)
POST PLATE

1793 (x8)
POST ANCHORING PLATE

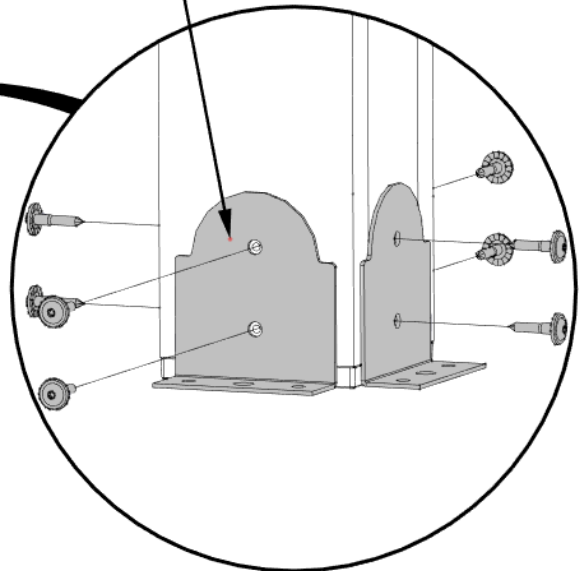
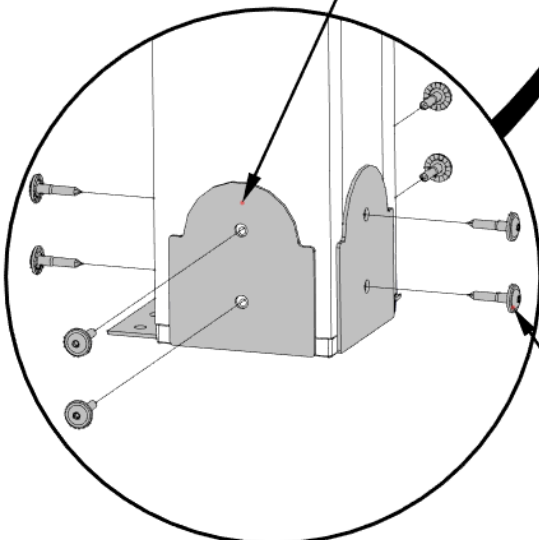

471 (x32)
LAG SCREW - 1 1/2"

STEP 51 - ID TAG ATTACHMENT

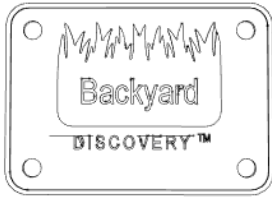

QTY	PART NUMBER	DESCRIPTION
4	H100387	SCREW PFH 8x1 1/4 BLK

A4M02158
BYD ID TAG PATIO
(x1)

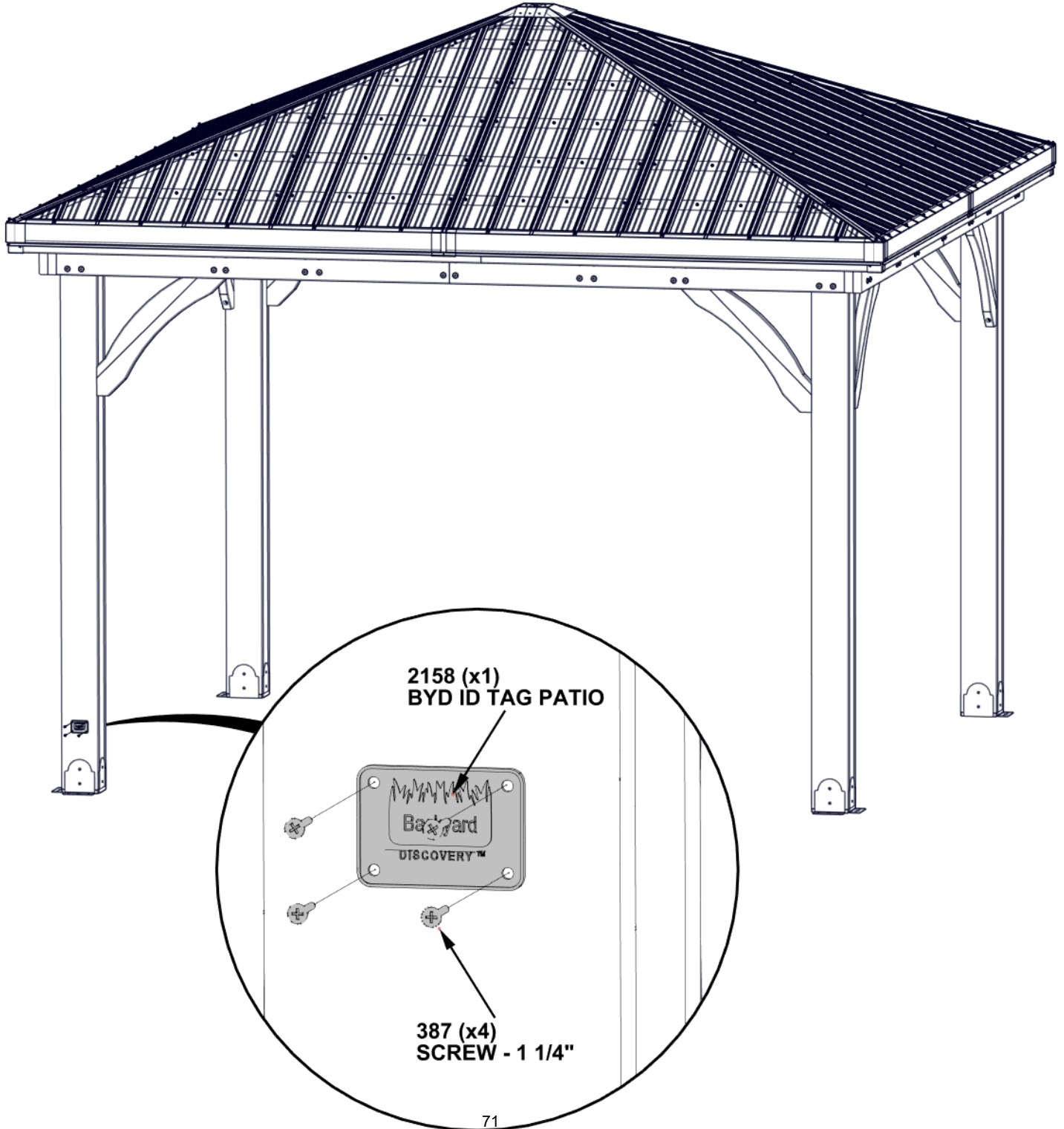

STEP 52 - ANCHORING

QTY	PART NUMBER	DESCRIPTION
16	H100120	CONCRETE ANCHOR 1/4"x2"
16	H100630	WASHER FLAT 8x19 BLK

- MANUFACTURER RECOMMENDS INSTALLATION ON CONCRETE SURFACE OR CONCRETE POST PADS AS SHOWN BELOW.
- FOR INSTALLATION ON A WOOD DECK, YOU MUST ENSURE THERE IS AMPLE STRUCTURAL SUPPORT UNDER DECK. HARDWARE NOT PROVIDED FOR DECK ATTACHMENT.

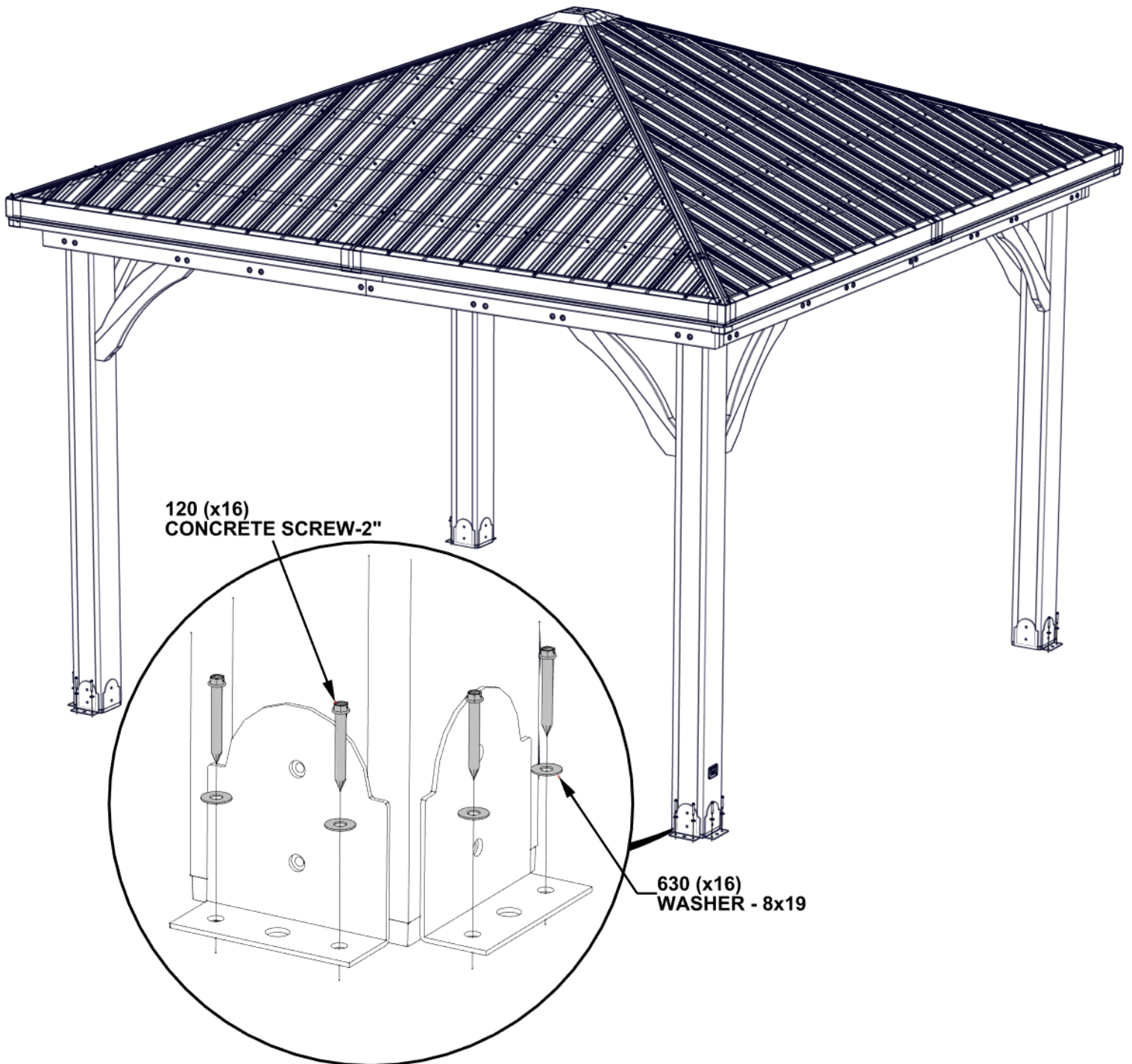

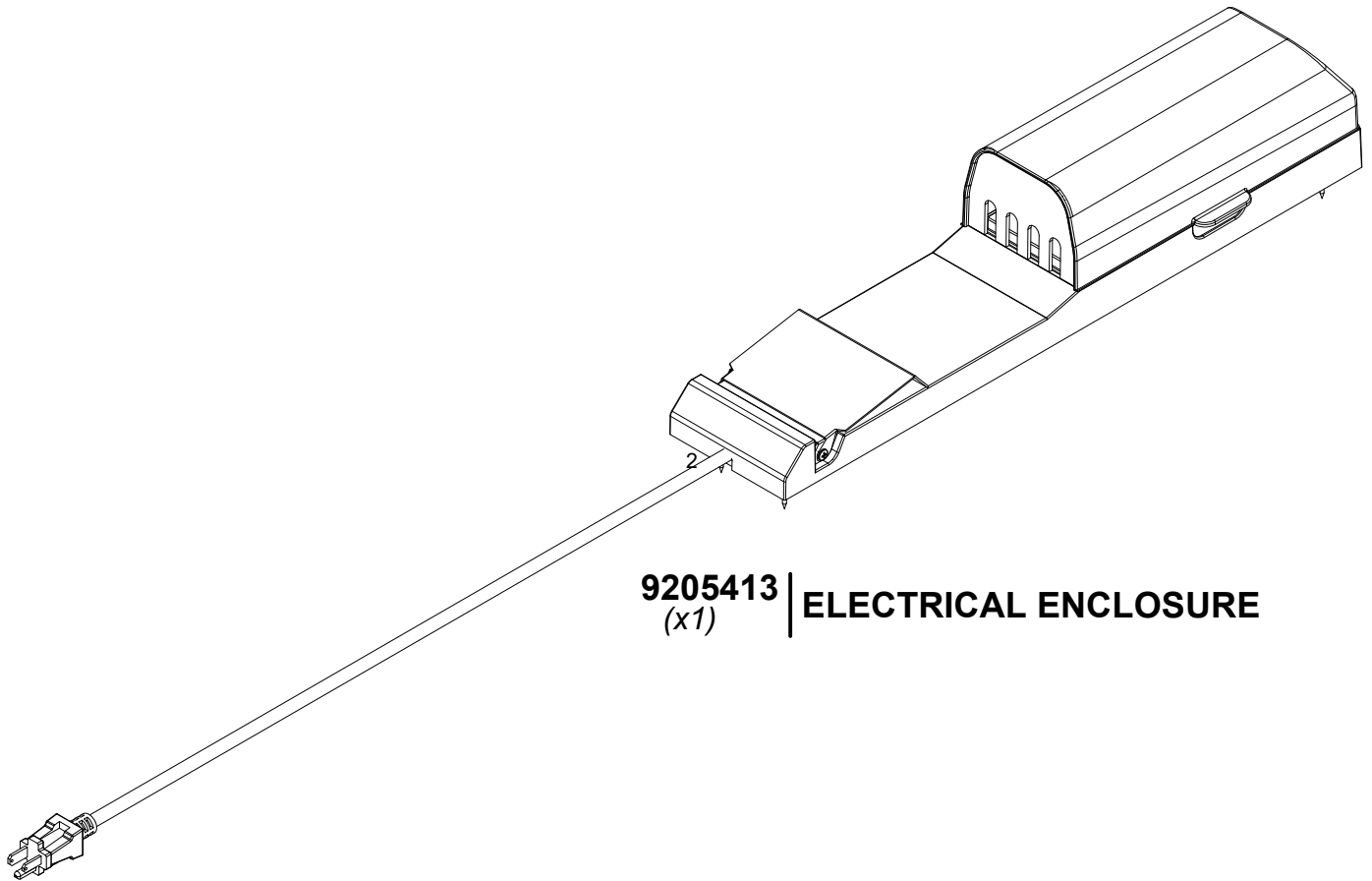

9205413 | **ELECTRICAL ENCLOSURE**
(x1)

FOR POWERPORT INSTALLATION REFER TO ASSEMBLY INSTRUCTIONS THAT COME PACKAGED WITH THE POWERPORT KIT. INSTALL ON ANY POST THAT IS DESIRED. FOLLOW DIRECTIONS FOR PROPER INSTALLATION.