

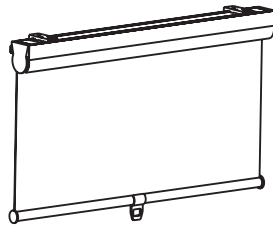



CORDLESS ROLLER SHADE



Check Components

Components		Shade Width	Shade Width
		Up to 39 in	40 in and up
Bracket		x 2	x 3
Screws		x 4	x 6
Anchors		x 4	x 6

Prepare necessary tools

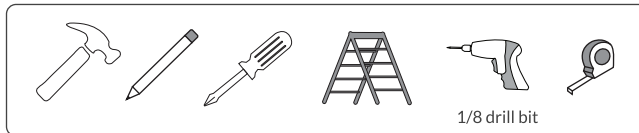

Warning

Avoid operating the shade up & down when the shade is not installed on a wall or in a window frame to prevent fabric sides from fraying.

STEP 1: DETERMINE INSIDE/CEILING, FLUSH, WALL OR OUTSIDE MOUNT

a. Inside/Ceiling or Flush Mount

(A minimum 2 1/4 in. depth is required or 3 1/4 in. depth for flush mounts.)

- 1) Position bracket approximately 1 to 2 inches from the ends of the headrail.
- 2) Mark the pre-drilled holes for the bracket using a pencil. If you have more than 2 brackets, position it equally.
- 3) Use the screws and anchors to install bracket holes.

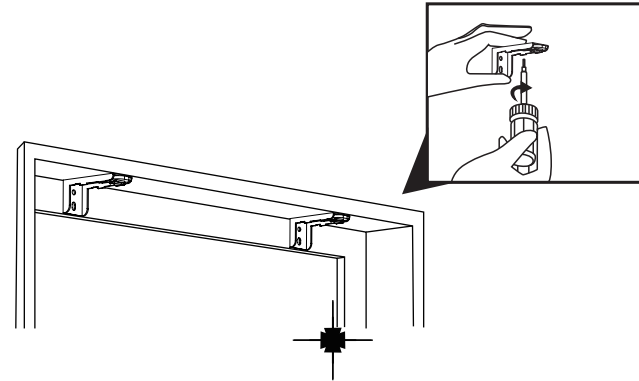

b. Wall or Outside Mount

(A minimum 1 3/8 inch flat wall space is necessary)

- 1) Position brackets approximately 1 to 2 inches from the ends of the headrail. If you have more than 2 brackets, position it equally.
- 2) Mark the pre-drilled holes for the bracket using a pencil.
- 3) Use the screws and anchors to install the bracket holes.

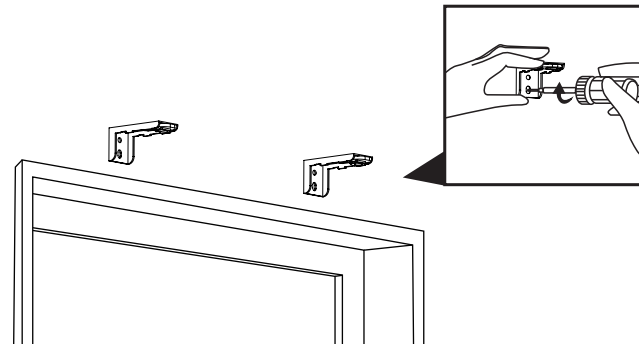

STEP 2: MOUNT THE SHADE IN BRACKET

- 1) Insert the top of shade into the back hook of bracket.
- 2) Push in the button on the front of the bracket and rotate the headrail upward until it is completely inserted, then release the button. Verify that the shade is securely attached before operating.
- 3) To remove the shade: while supporting the shade's weight, push the button to release the shade. Rotate the headrail downward to remove from bracket hook.

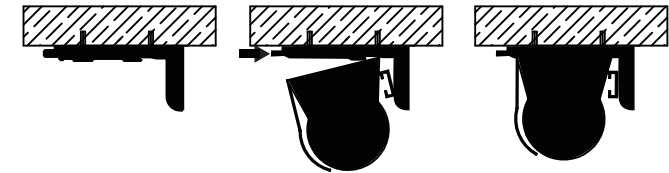

STEP 3: HOW TO OPERATE

To lower the shade: grip the handle and slowly pull straight down.

To raise the shade: grip the handle and lift slowly until the desired height is reached.

Important Note:

Always push and pull at the center of the shade to ensure that the bottom of the shade remains even (i.e. parallel to the top of the shade). If the shade becomes uneven, slowly pull it all the way down, and then lift to the desired position.

