

# ASSEMBLY INSTRUCTIONS

ITEM NO.WF302656

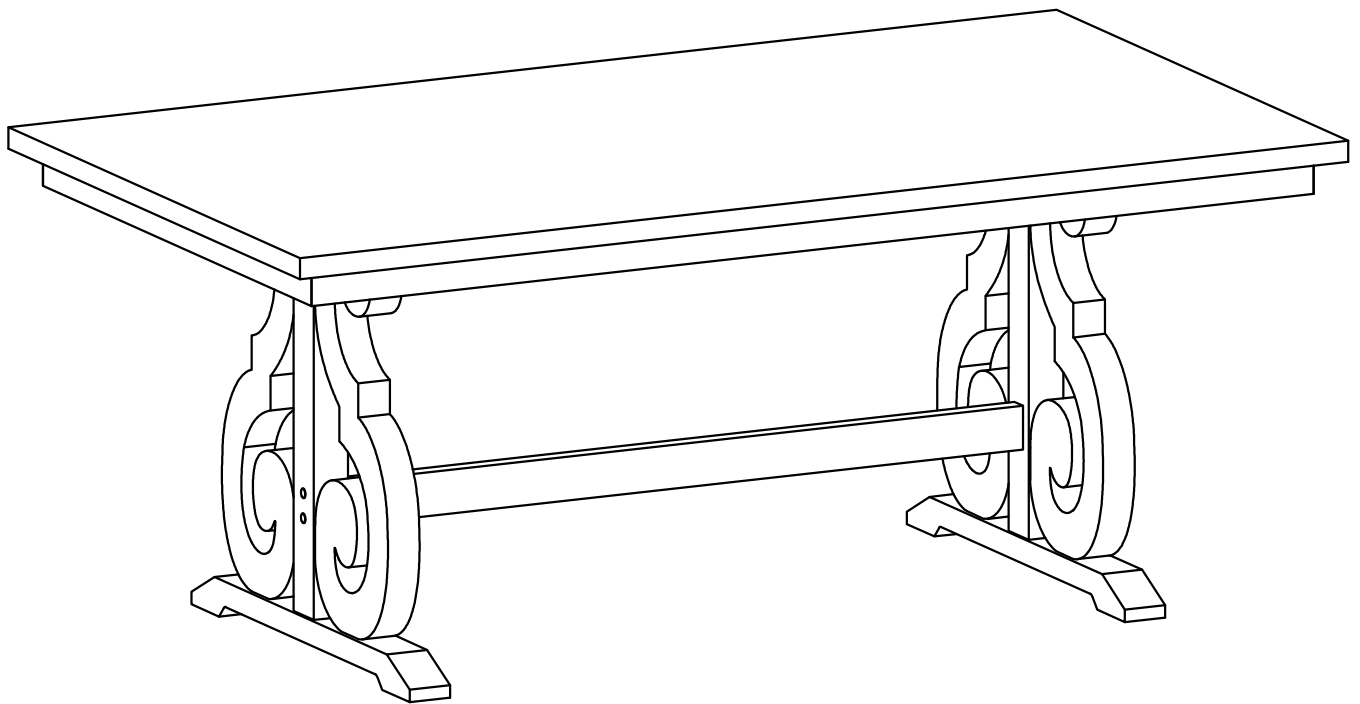





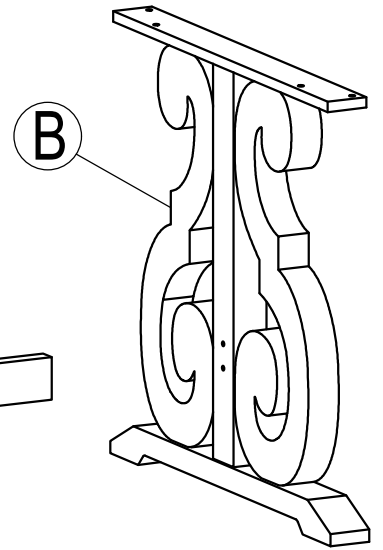
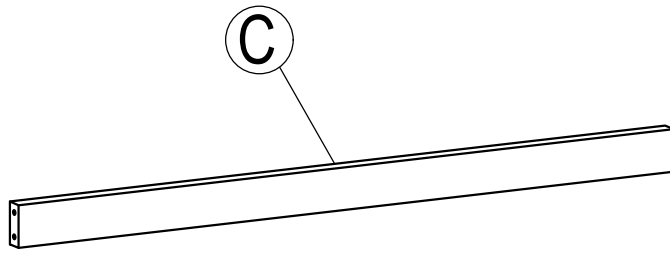
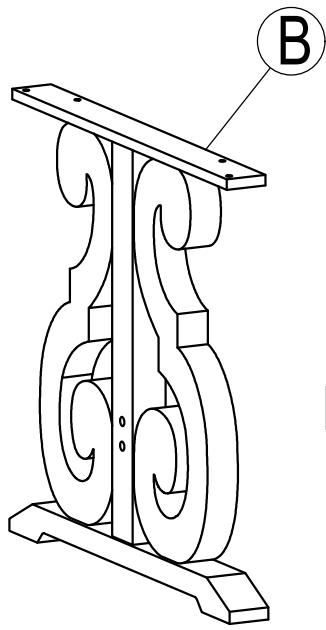
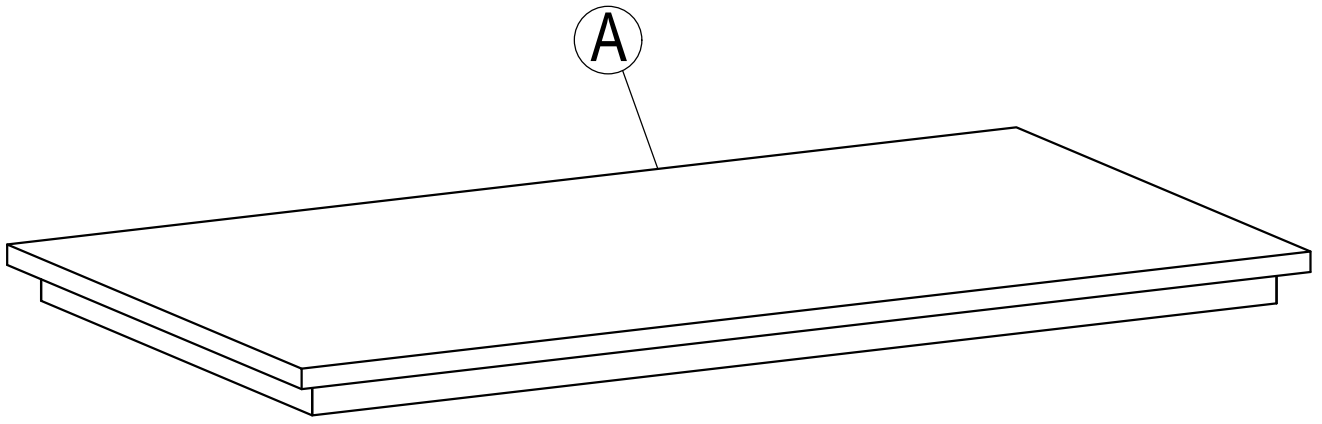

## IMPORTANT NOTE :

- ① PLACE ALL PARTS ON A CLEAN AND SMOOTH SURFACE SUCH AS A RUG OR CARPET TO AVOID THE PARTS FROM BEING SCRATCHED.
- ② BEFORE YOU BEGIN,KINDLY FOLLOW THE ASSEMBLY INSTRUCTIONS STEP BY STEP.
- ③ DO NOT TIGHTEN ALL SCREWS AND BOLTS UNTIL THE TABLE IS FULLY SET-UP.

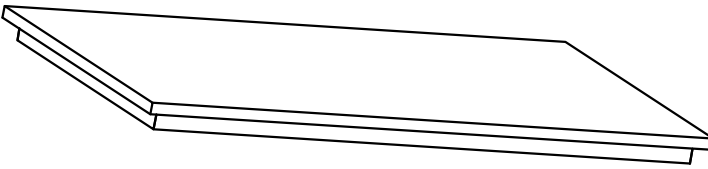
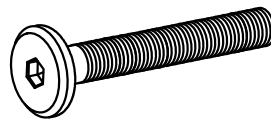
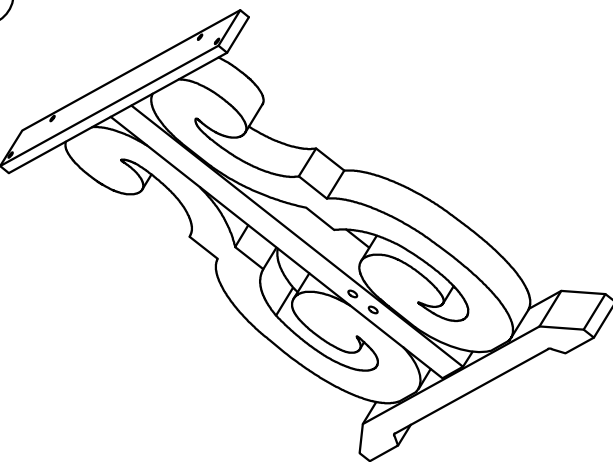
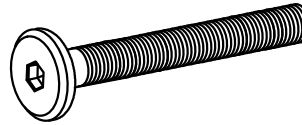
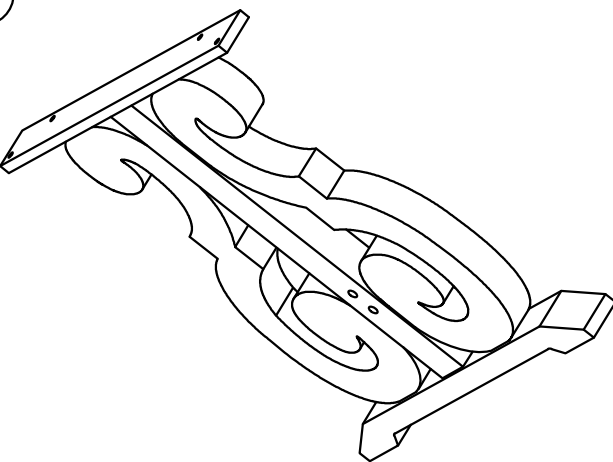

# Part List

# Hardware List

<p><b>(A)</b></p> 	<p><b>(1)</b></p>  <p>Ø 5/16" x 40 mm</p>
<p>TOP TABLE (1 pc)</p>	<p>BOLT (8 pcs)</p>
<p><b>(B)</b></p> 	<p><b>(2)</b></p>  <p>Ø 5/16" x 65 mm</p>
<p>LEG (2 pcs)</p>	<p>BOLT (4 pcs)</p>
<p><b>(B)</b></p> 	<p><b>(3)</b></p>  <p>Ø5/16" x 13 mm</p>
<p>LEG (2 pcs)</p>	<p>FLAT WASHER (12 pcs)</p>
<p><b>(C)</b></p> 	<p><b>(4)</b></p>  <p>Ø5/16" x 19 mm</p>
<p>STRETCHER (1 pc)</p>	<p>LOCK WASHER (8 pcs)</p>
<p><b>(C)</b></p> 	<p><b>(5)</b></p>  <p>4 mm</p>
<p>STRETCHER (1 pc)</p>	<p><b>(6)</b></p> 
<p>STRETCHER (1 pc)</p>	<p>WOOD PLUG (4pcs)</p>

# STEP 1:

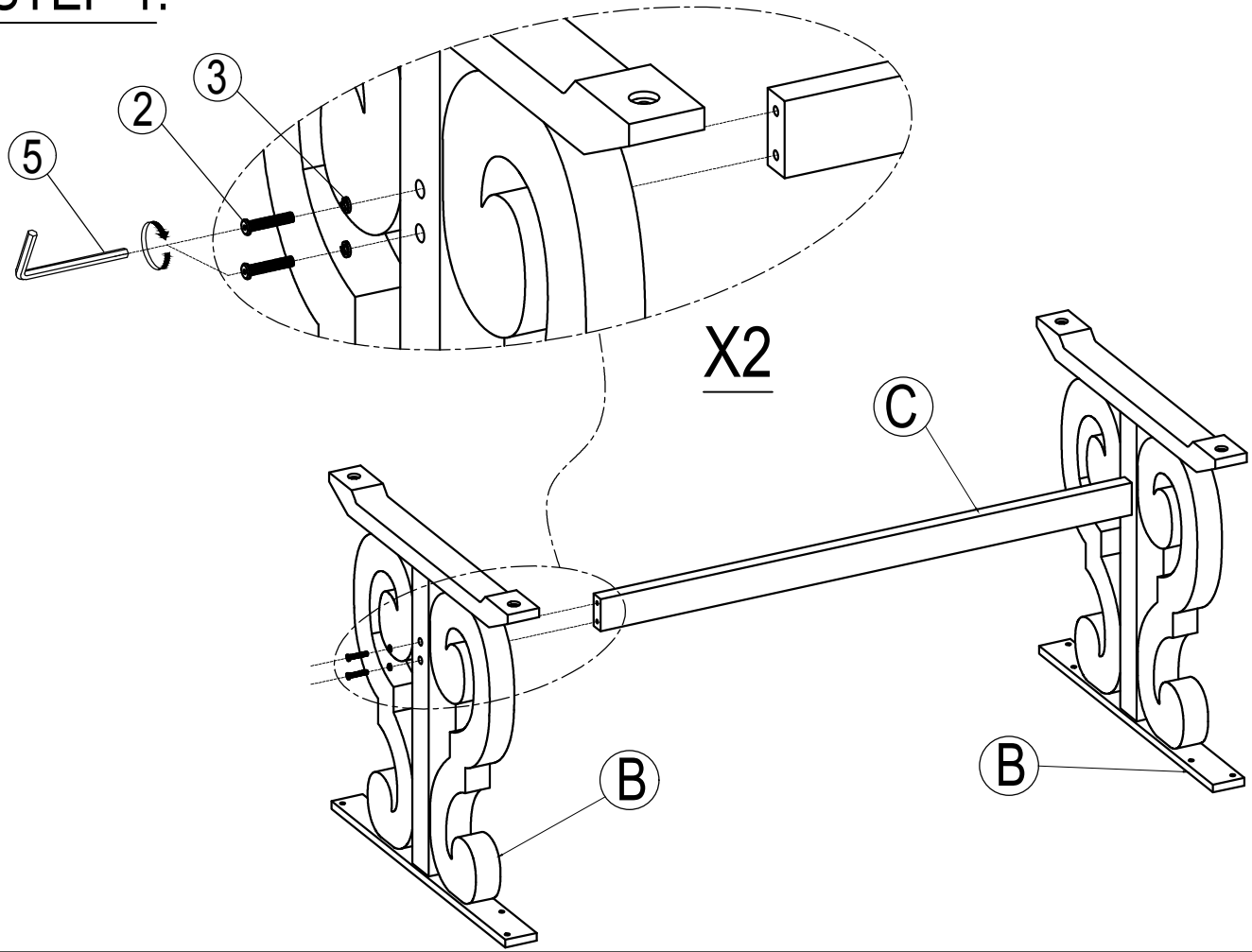

# STEP 2:

