

WF315452
WF315453

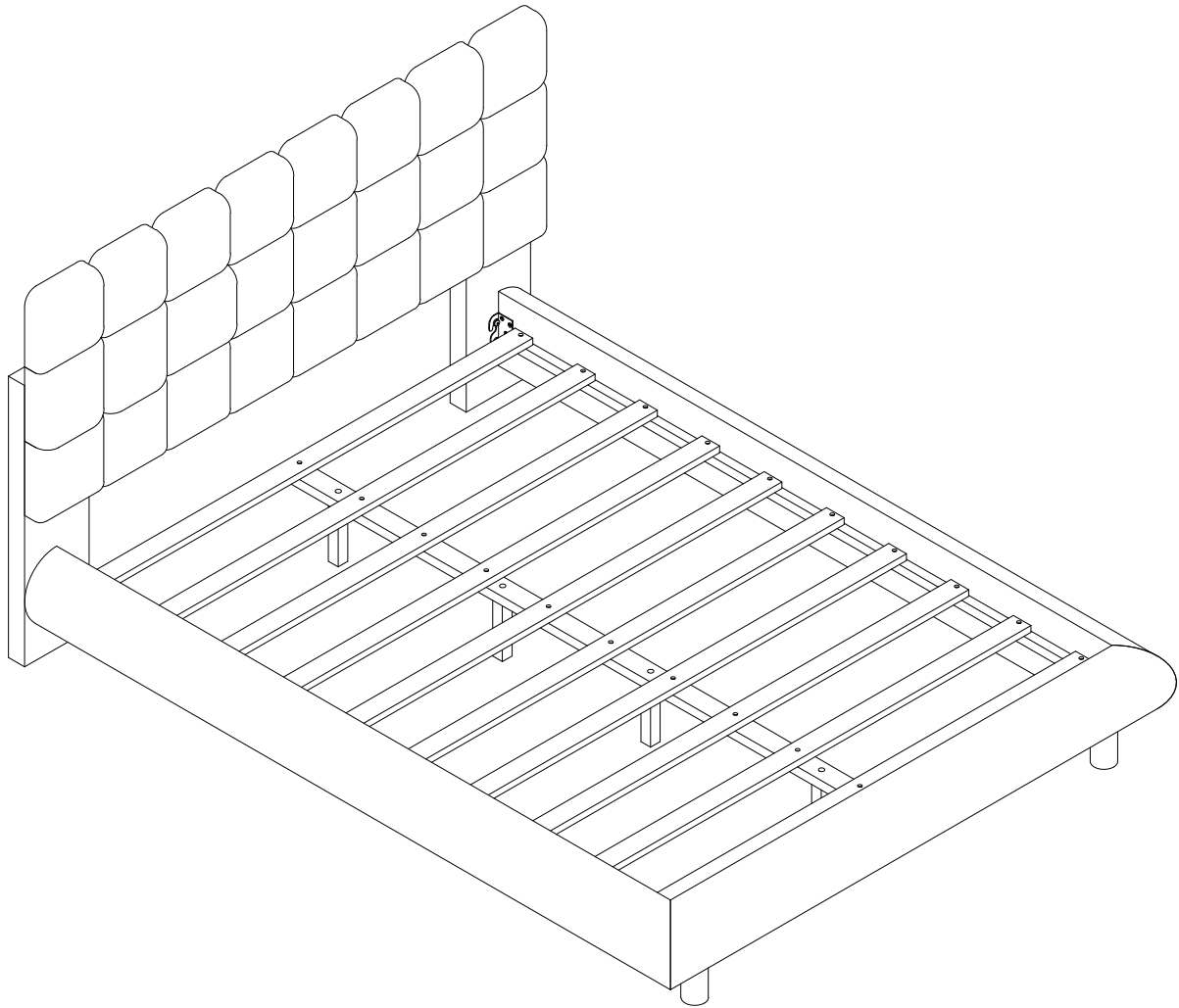

ASSEMBLY INSTRUCTIONS

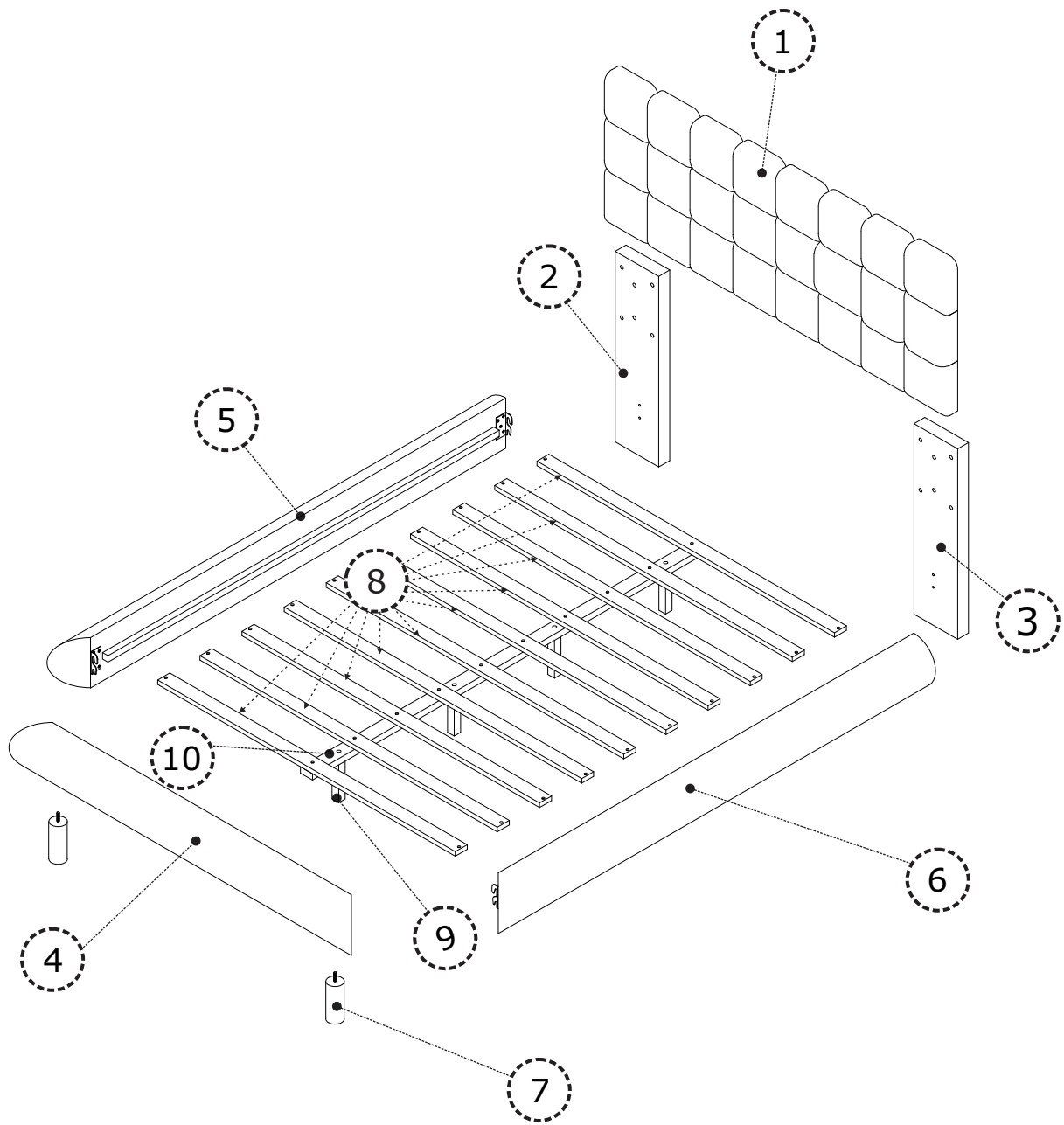

PARTS

Check that you've received
all parts listed below.

BOX: 1/2
WF315452

1 x 1

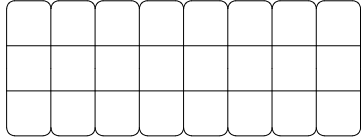

Head Board

PARTS

Check that you've received
all parts listed below.

BOX: 2/2
WF315453

2 x 1

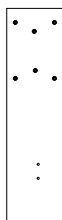

Head Leg left

3 x 1



Head Leg Right

4 x 1



Foot Board

5 x 1



Side Board Right

6 x 1



Side Board Left

7 x 2



Legs

8 x 10

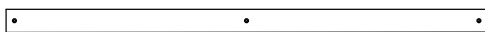

Slats

9 x 4

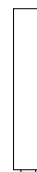

Support Legs

10 x 1



Support Slats









Hardware

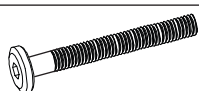

HARDWARE

Check that you've received all hardware listed below.

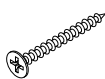
Hardware List

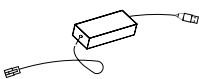
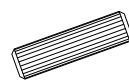
No.	OUTLOOK	DESC	QTY
(A)		Bolts 5/16"x30 mm	8
(B)		Bolts 5/16"x38 mm	4
(C)		Bolts 5/16"x70 mm	8
(D)		Plain washer Ø19x1.5 mm	20
(E)		Spring washer Ø13x1 mm	20
(F)		Allen key 80x30x4 mm	1
(G)		Screws Ø4x30 mm	30
(H)		Led - Key	1
(I)		Led - Controller	1
(K)		Dowel Ø10 x 30 mm	4

STEP 1

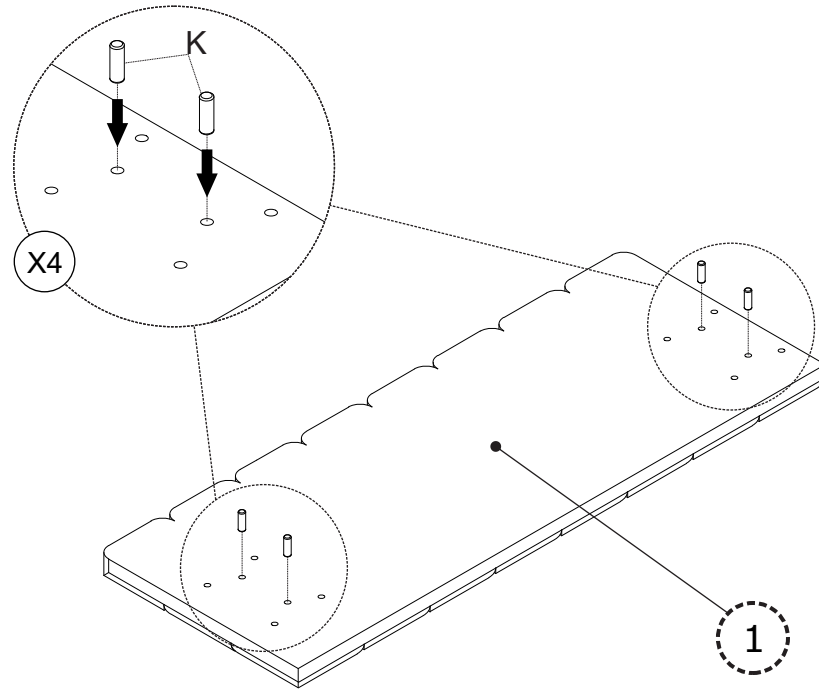
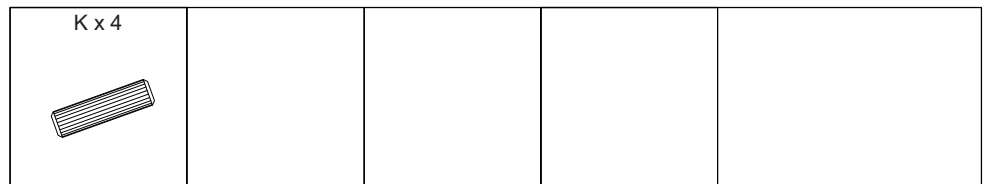

STEP 2

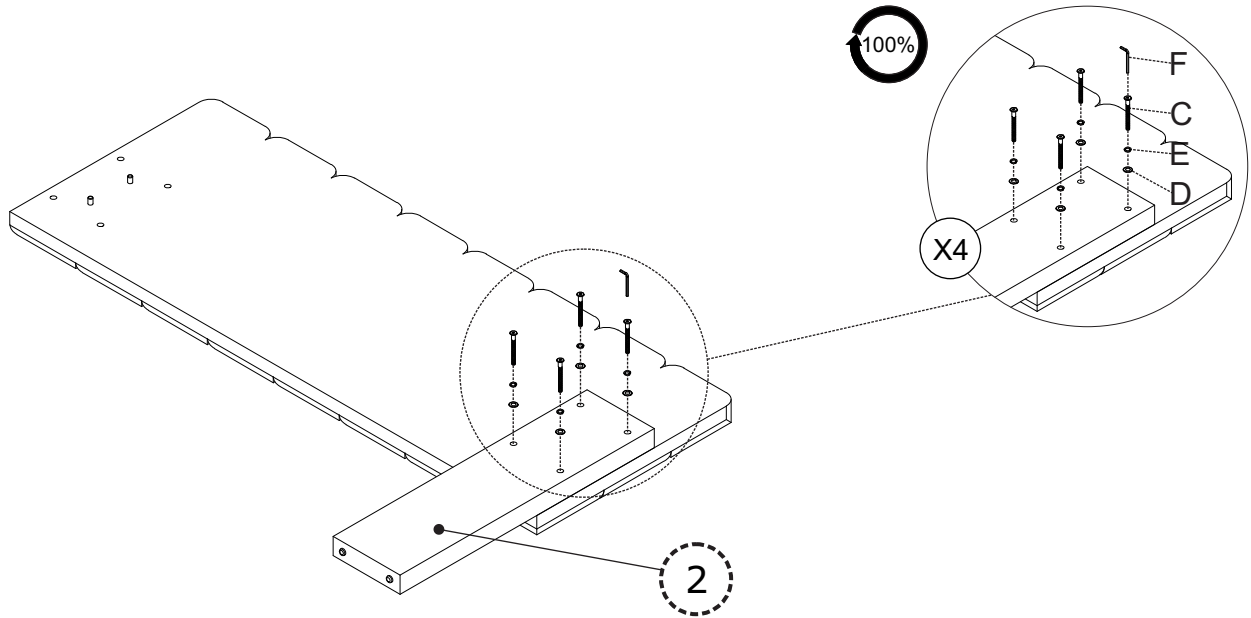
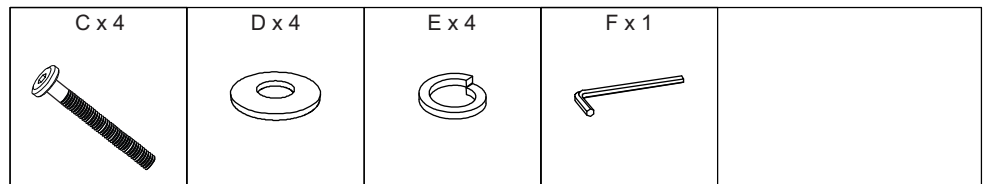

STEP 3

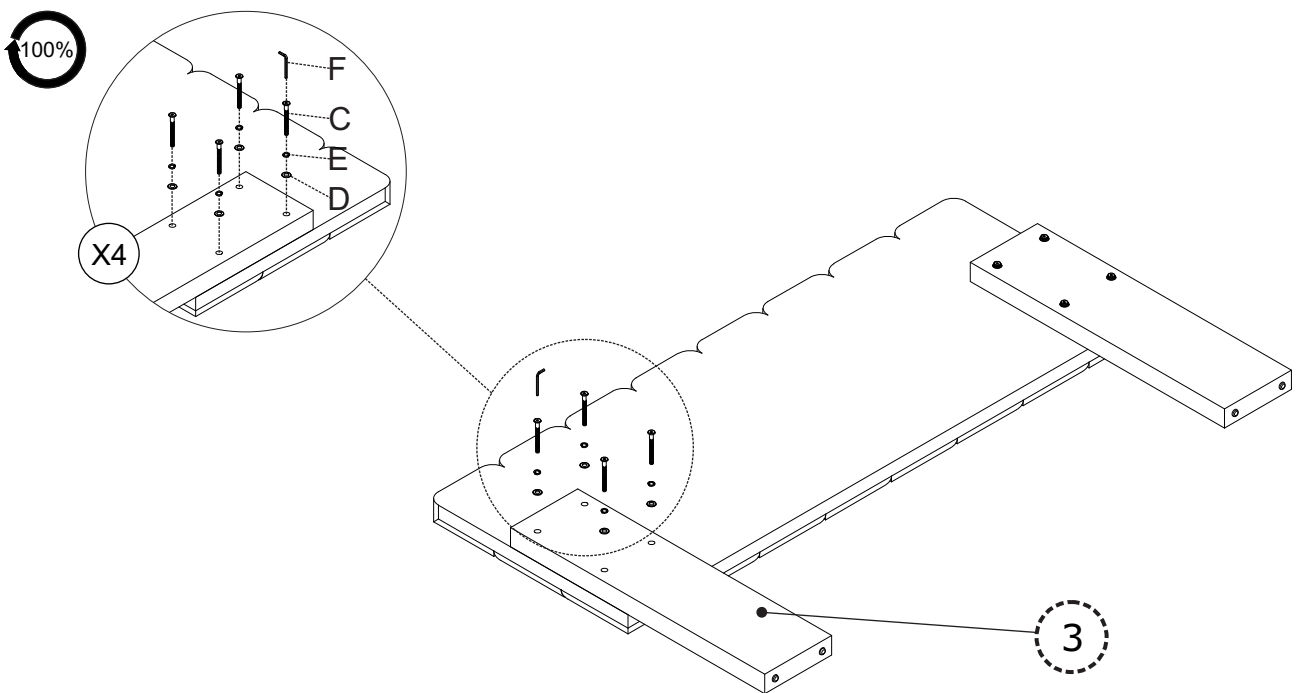
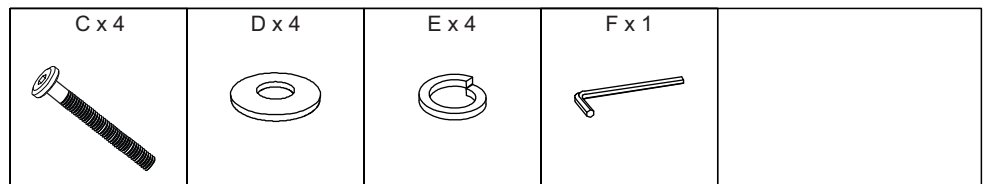

STEP 4

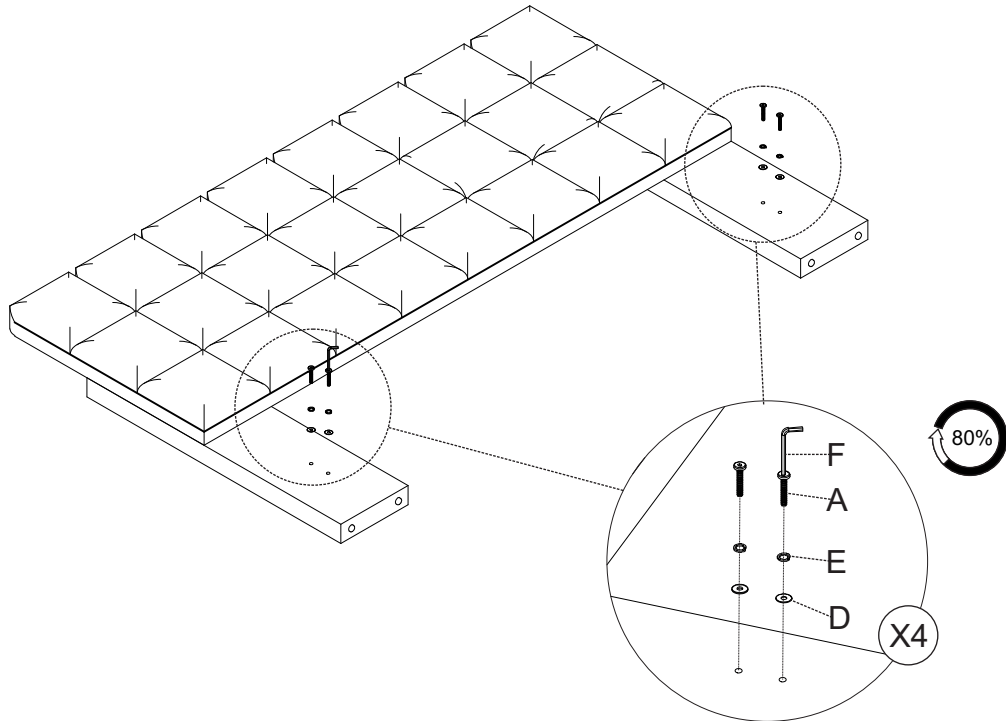
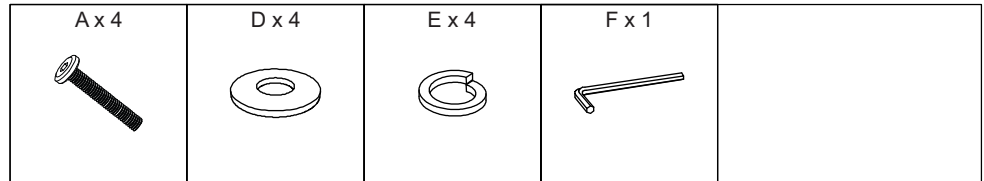

STEP 5

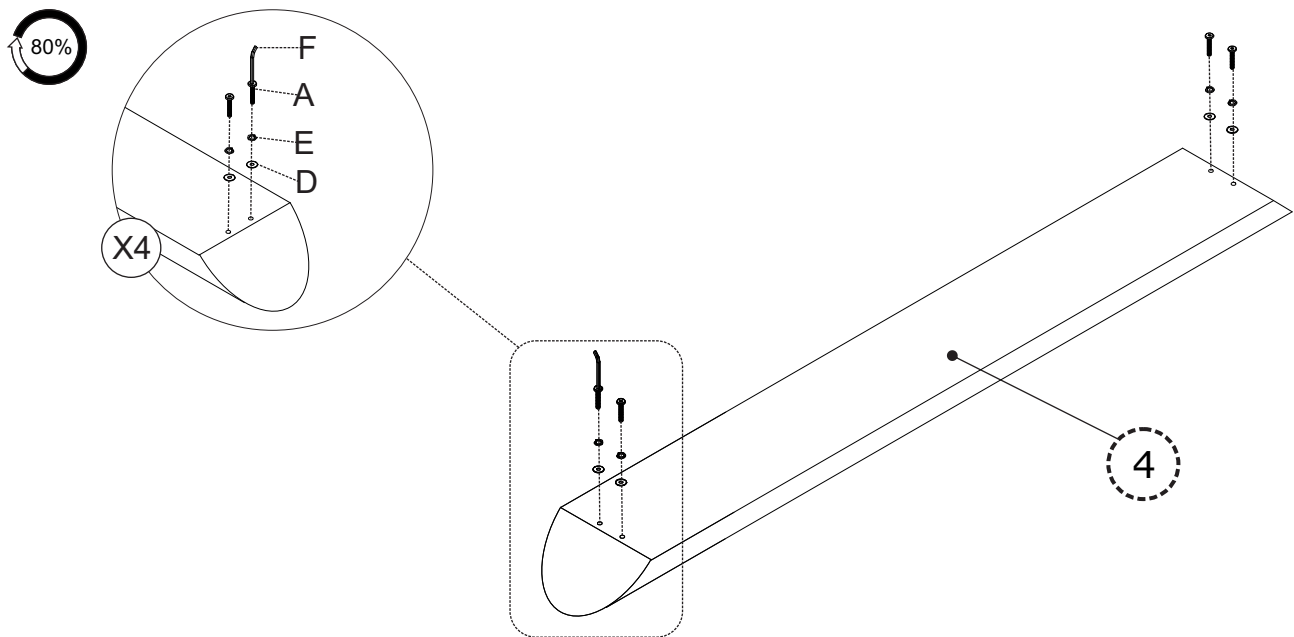
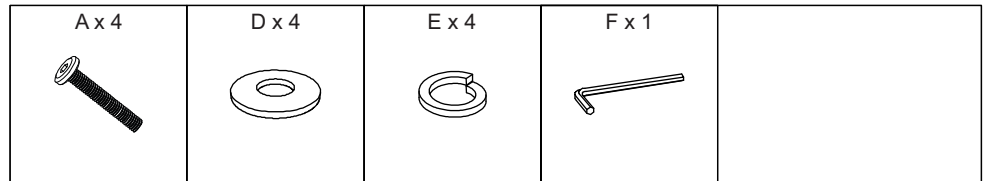

STEP 6

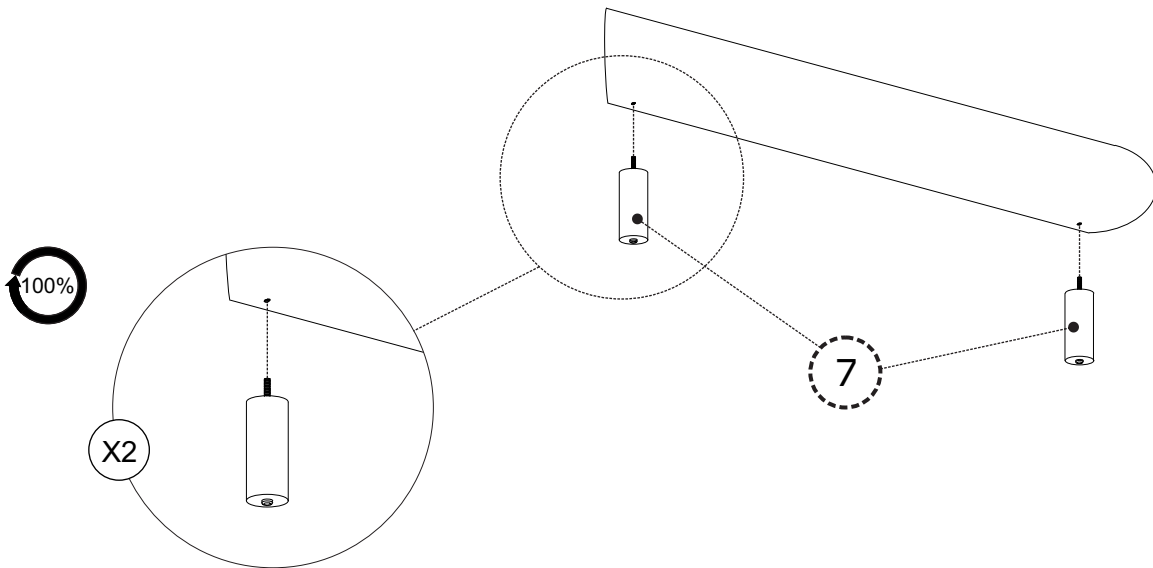
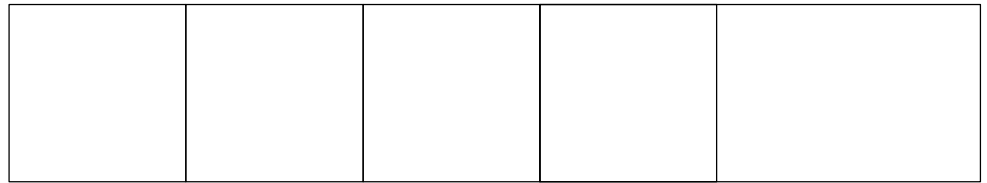

STEP 7

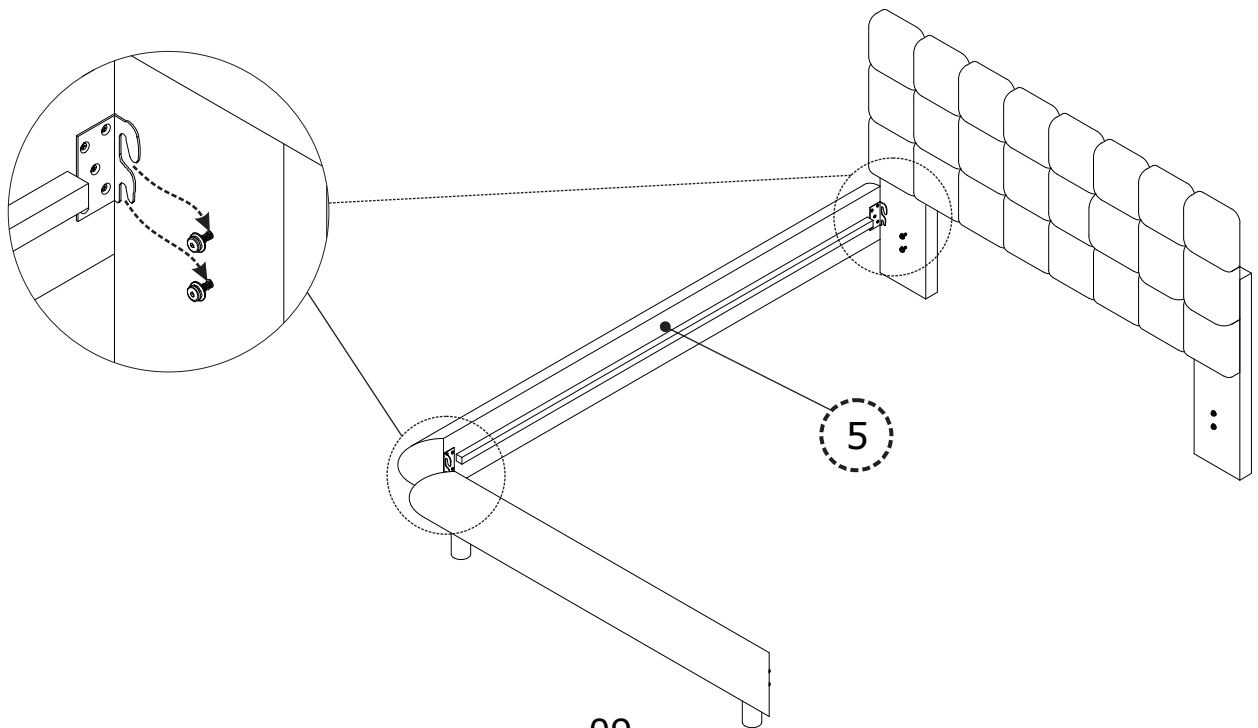
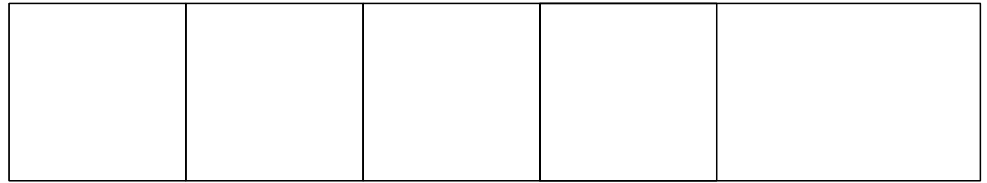

STEP 8

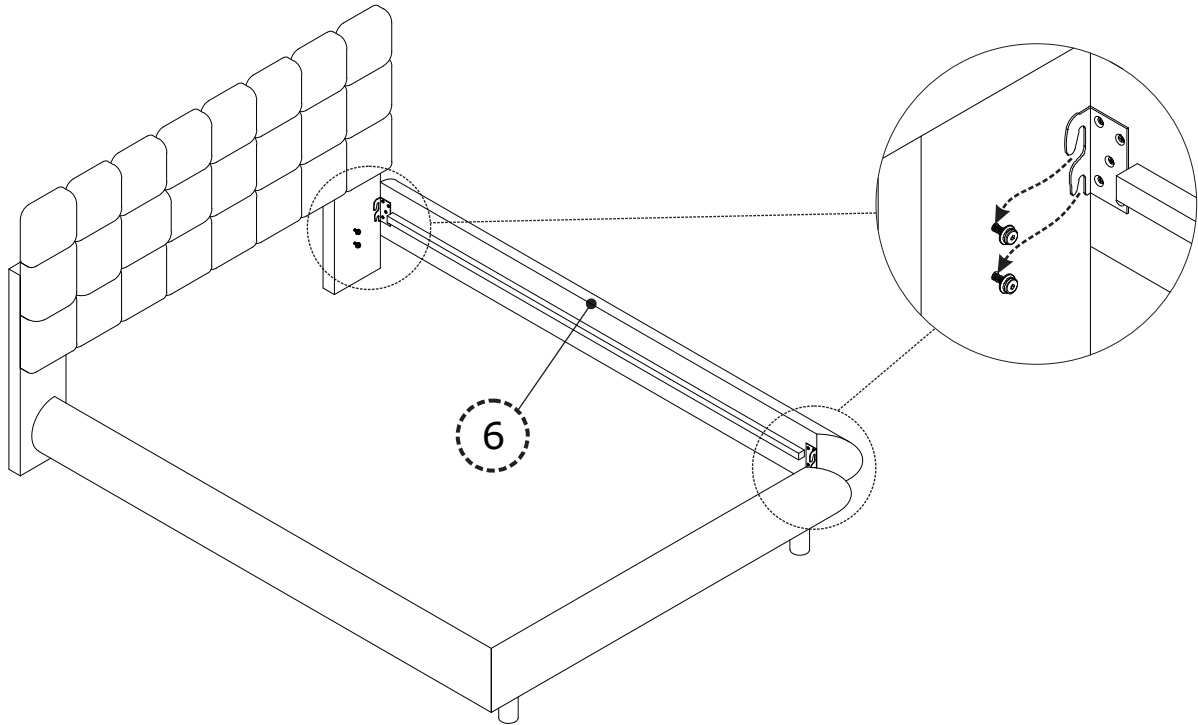
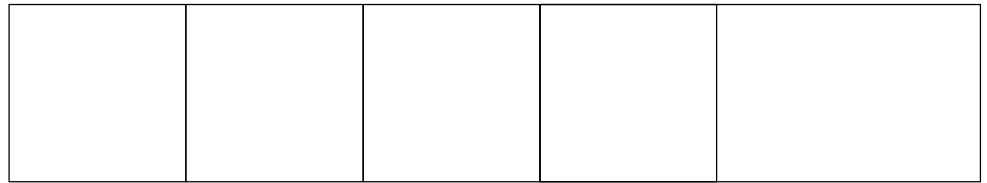

STEP 9

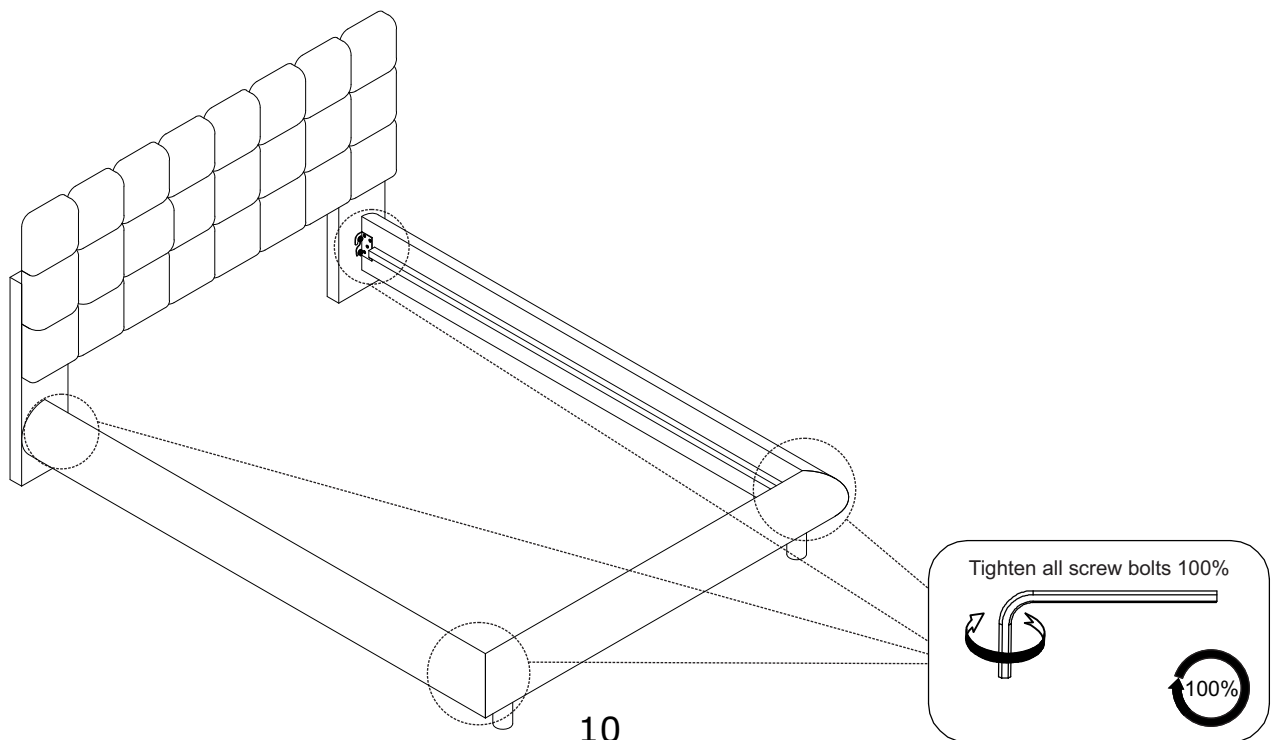
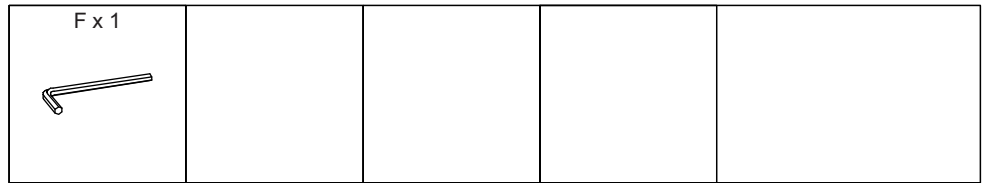



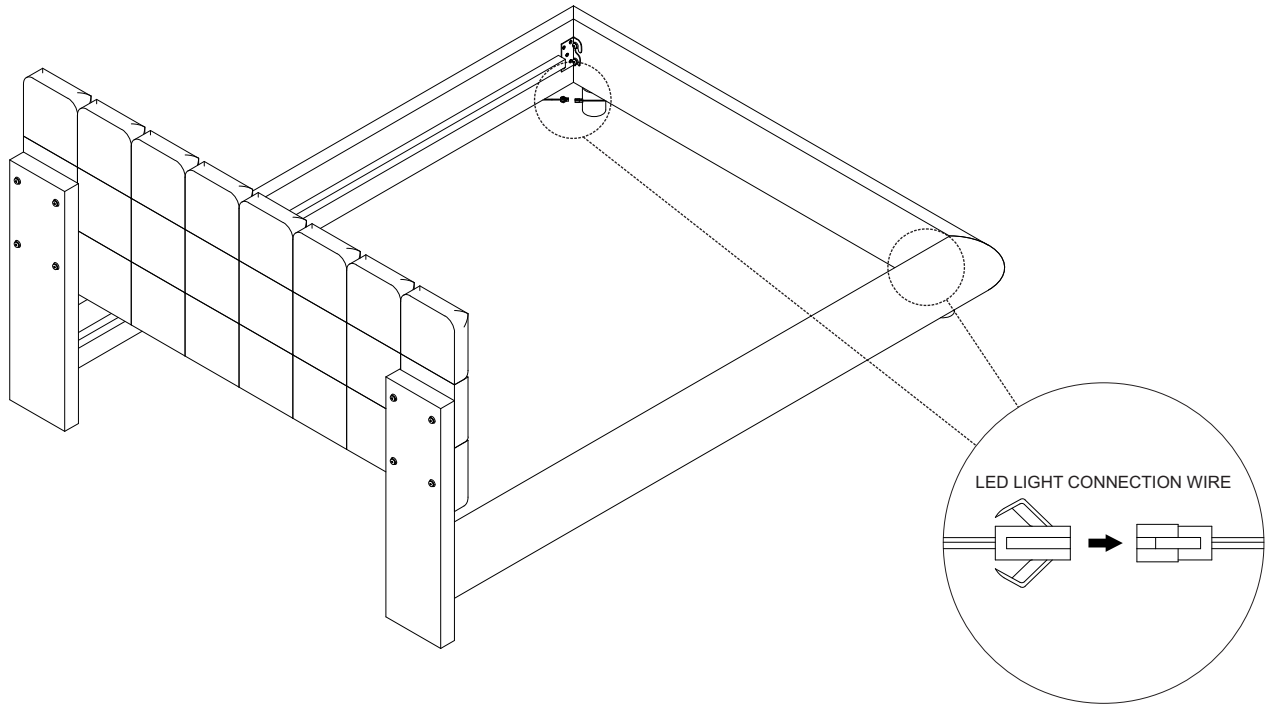
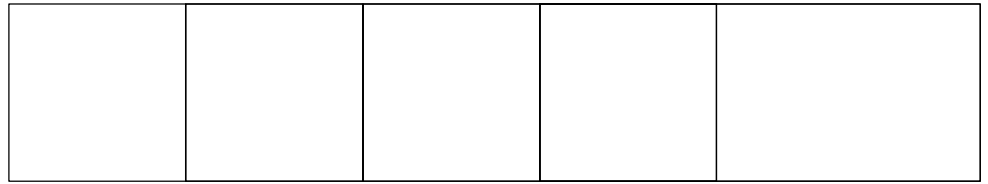

STEP 10

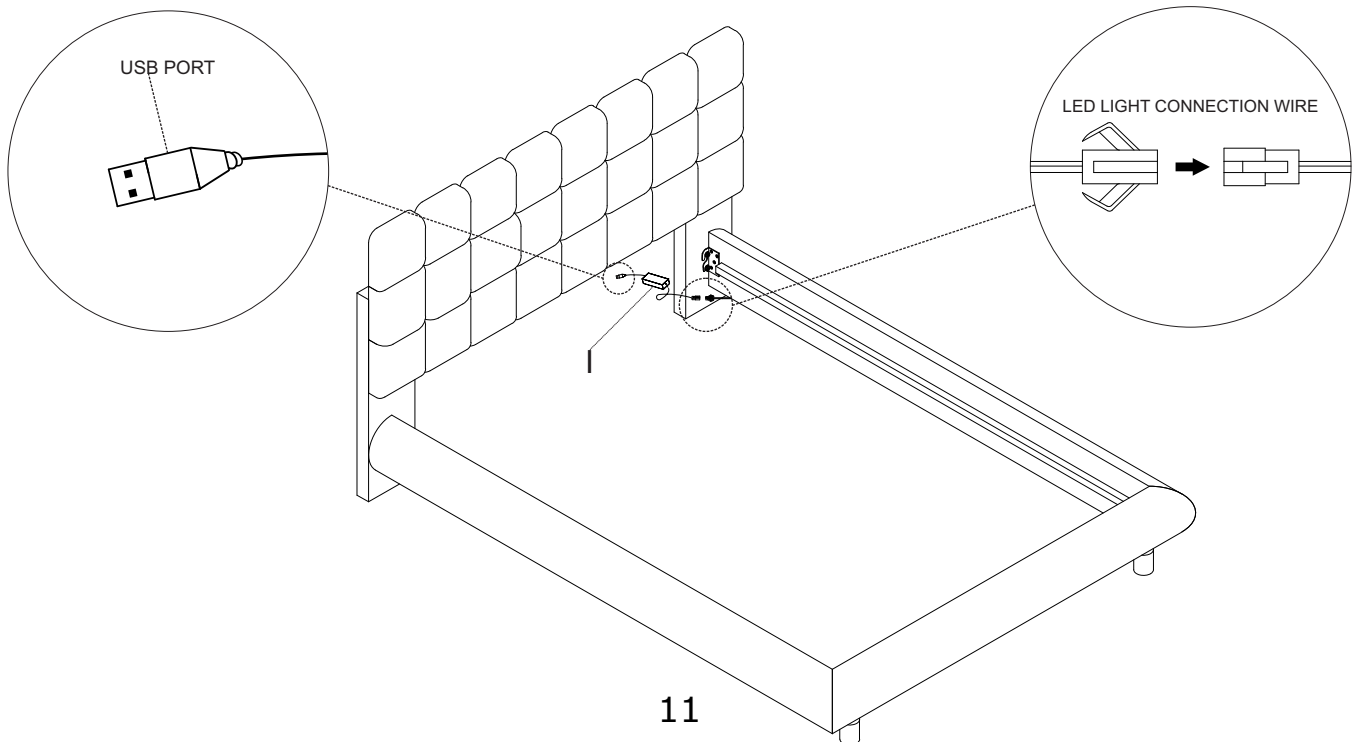
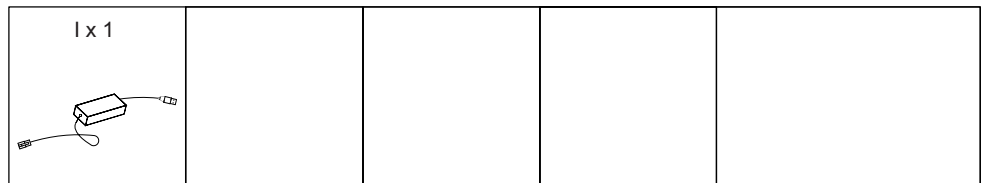

STEP 11



STEP 12

B x 4 	D x 4 	E x 4 	F x 1 	
--	--	--	--	--

100%

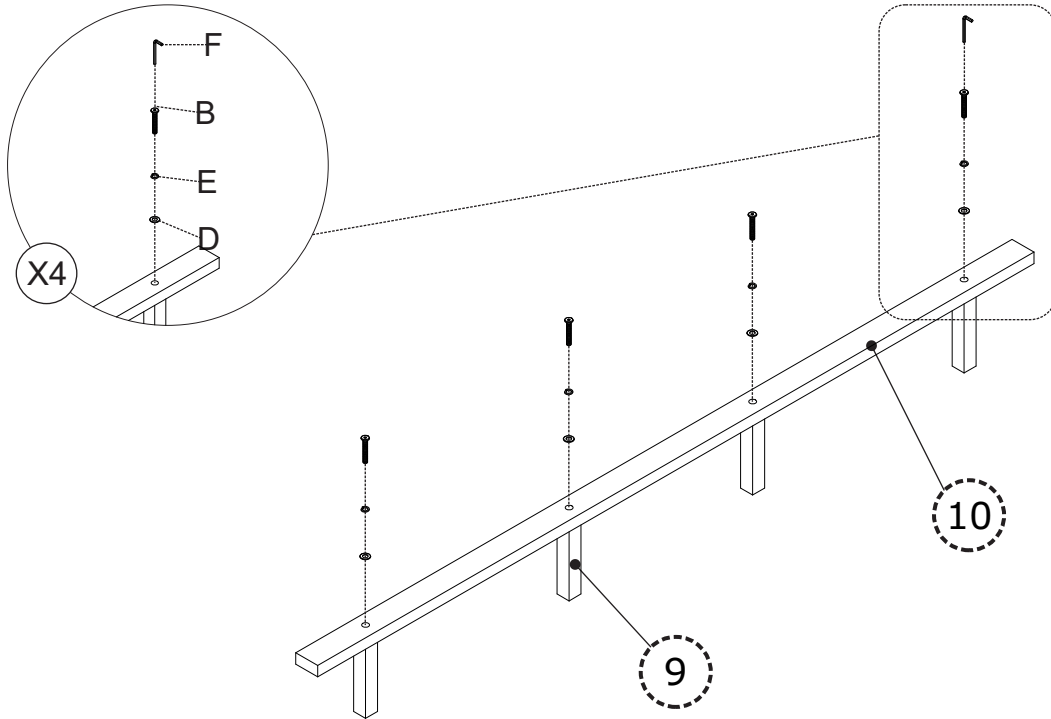

STEP 13

--	--	--	--	--

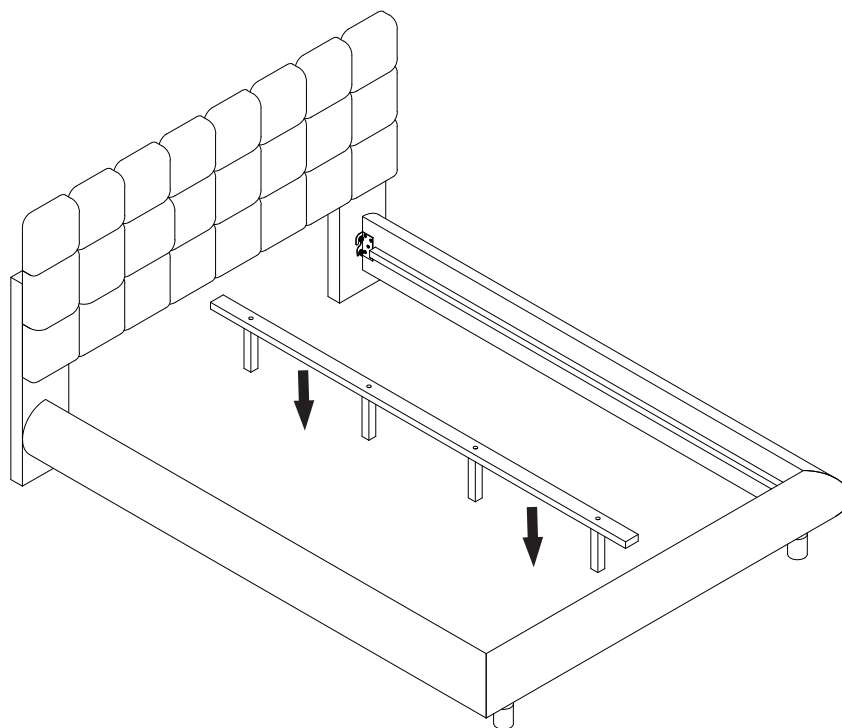

STEP 14

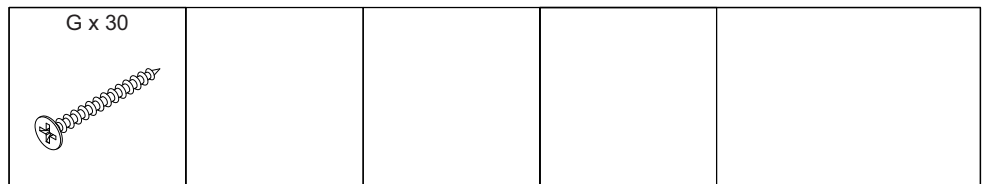

100%

