

ASSEMBLY INSTRUCTION

DINNING SET

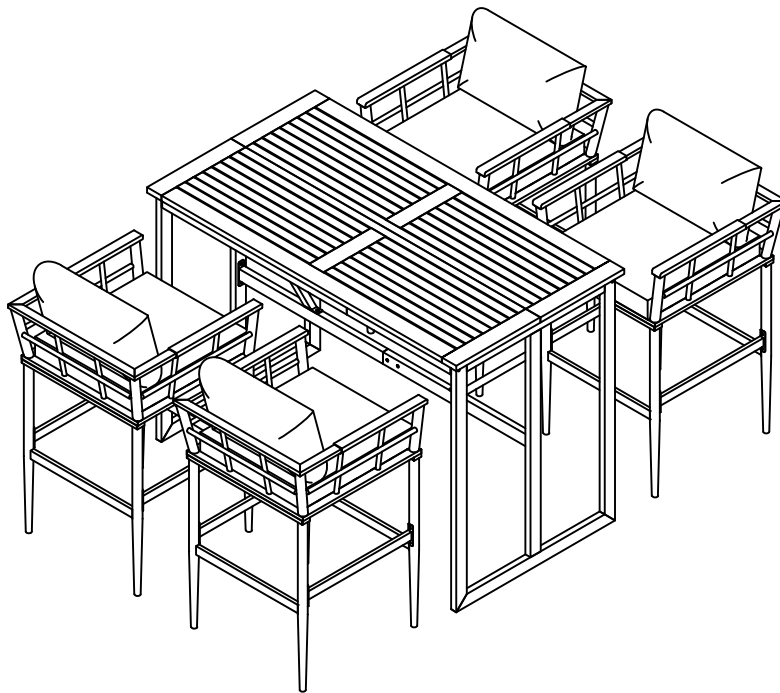

WF303405; WF303406; WF303407;WF303408

Notice

- 1. 50% Tighten before fixings all screws, Allen wrench is recommended instead of an electric drill.**
- 2. Place the item on a flat ground to adjust and make sure it remains stable.**
- 3. Tighten up all screws with tools gradually.**
- 4. If the screws are not aligned with holes during assembly, please loosen all all the other screws to 50% and continue the assembly process.**
- 5. If the item is not stable, please loosen all the screws, adjust it on a flat ground and tighten up all screws again.**
- 6. Note: If one or more screws are fully tightened during assembly, chances are the others will not be aligned with holes. In addition, all the holes are designed to be relatively larger to provide more space for the adjustment of the screws.**

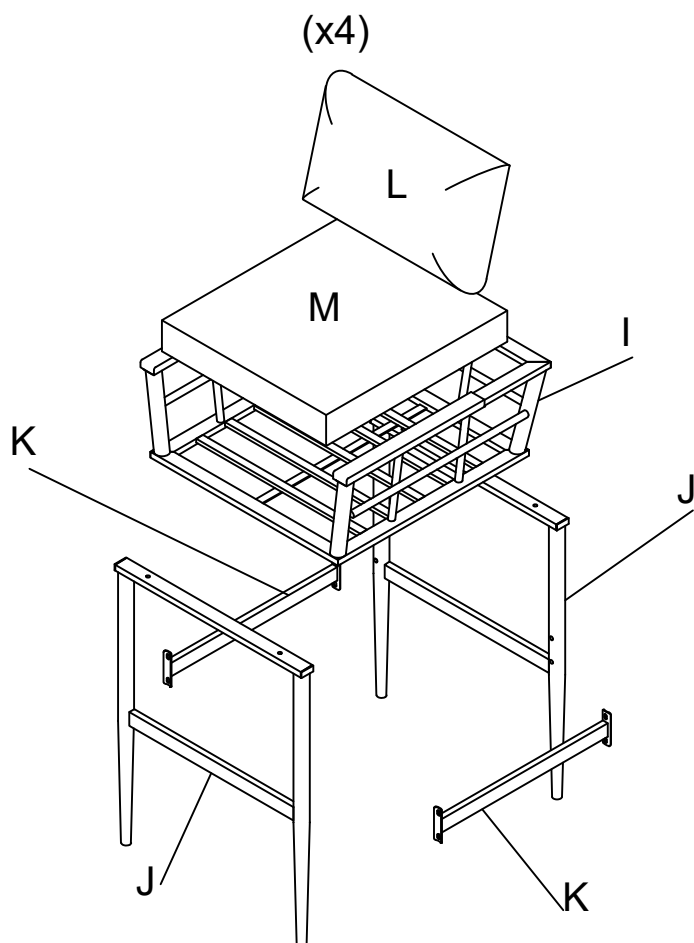
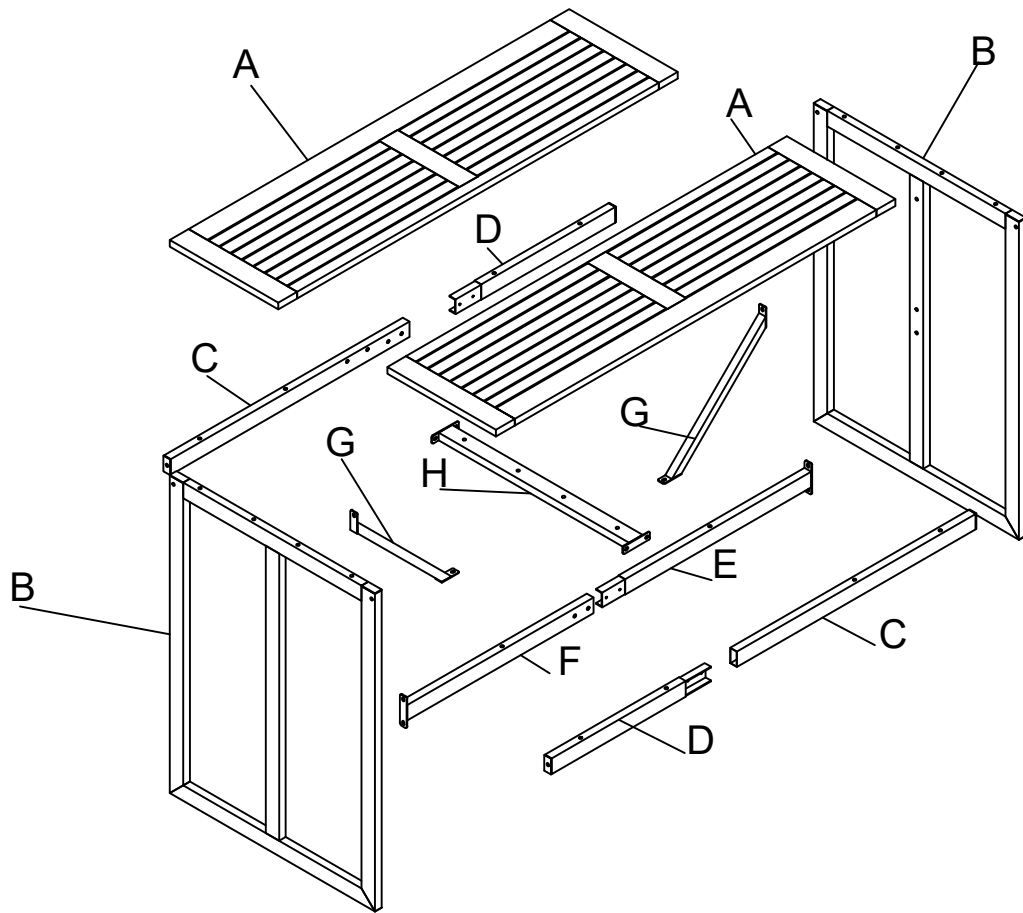

A

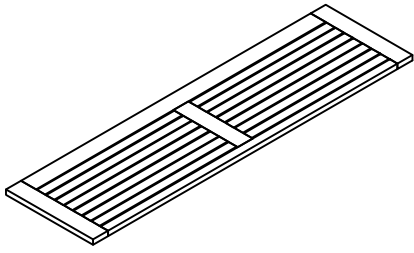

2 pcs

B

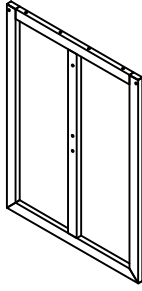

2 pcs

C

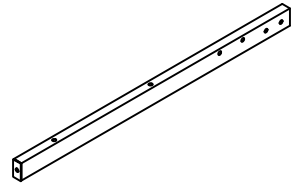

2 pcs

D

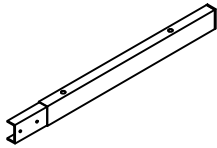

2 pcs

E

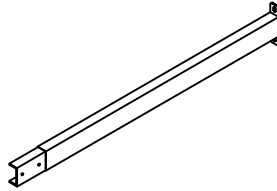

1 pc

F

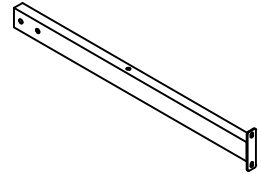

1 pc

G

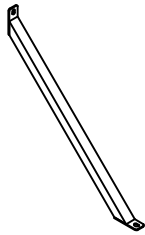

2 pcs

H

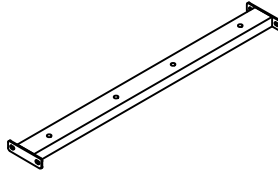

1 pc

I

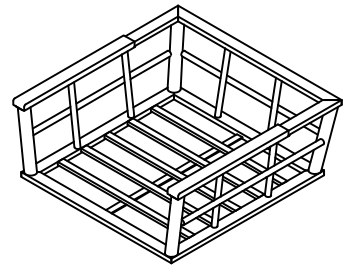

4 pcs

J

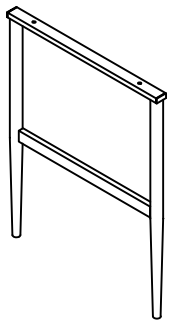

8 pcs

K

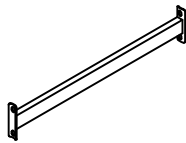

8 pcs

L

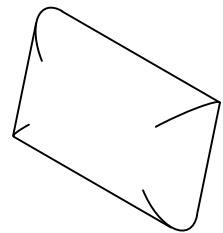

4 pcs

M

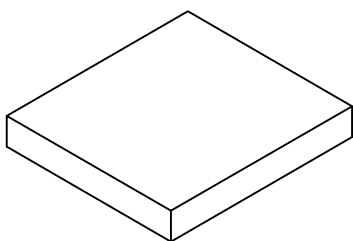

4 pcs

1

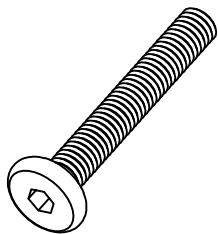

**Bolt M6x65 mm
(16 pcs)+extra 2 pcs**

2

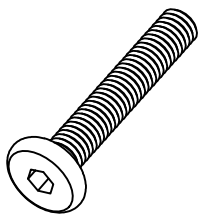

**Bolt M6x40 mm
(8 pcs)+extra 1 pc**

3

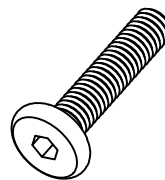

**Bolt M6x25 mm
(16 pcs)+extra 2 pc**

4

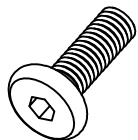

**Bolt M6x15 mm
(50 pcs)+extra 3 pcs**

5

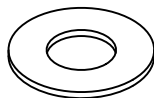

**Washer
(90 pcs) + extra 3 pcs**

6

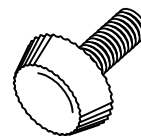

**Plastic feet
(20 pcs)**

7

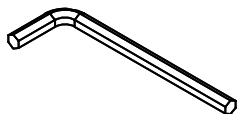

Allen key (2 pcs)

WF303405

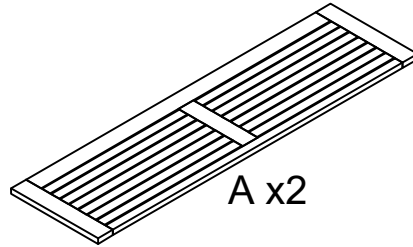

A x2

WF303406

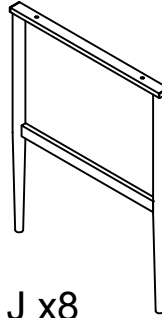

J x8

WF303407

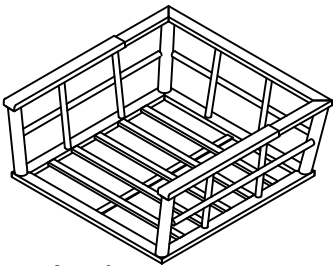

I x4

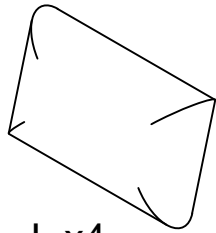

L x4

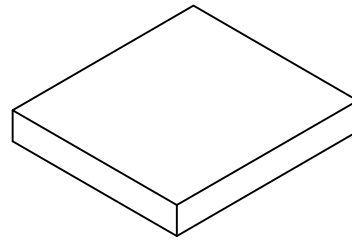

M x4



HARDWARE

WF303408

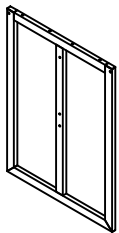

B x2

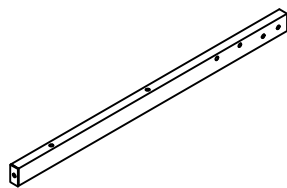

C x2

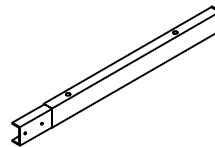

D x2

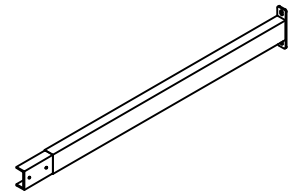

E x1

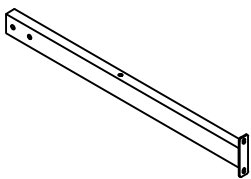

F x1

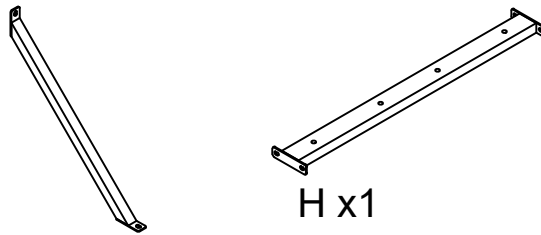

G x2

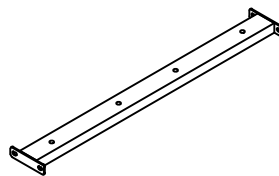

H x1

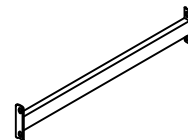

K x8

Step 1

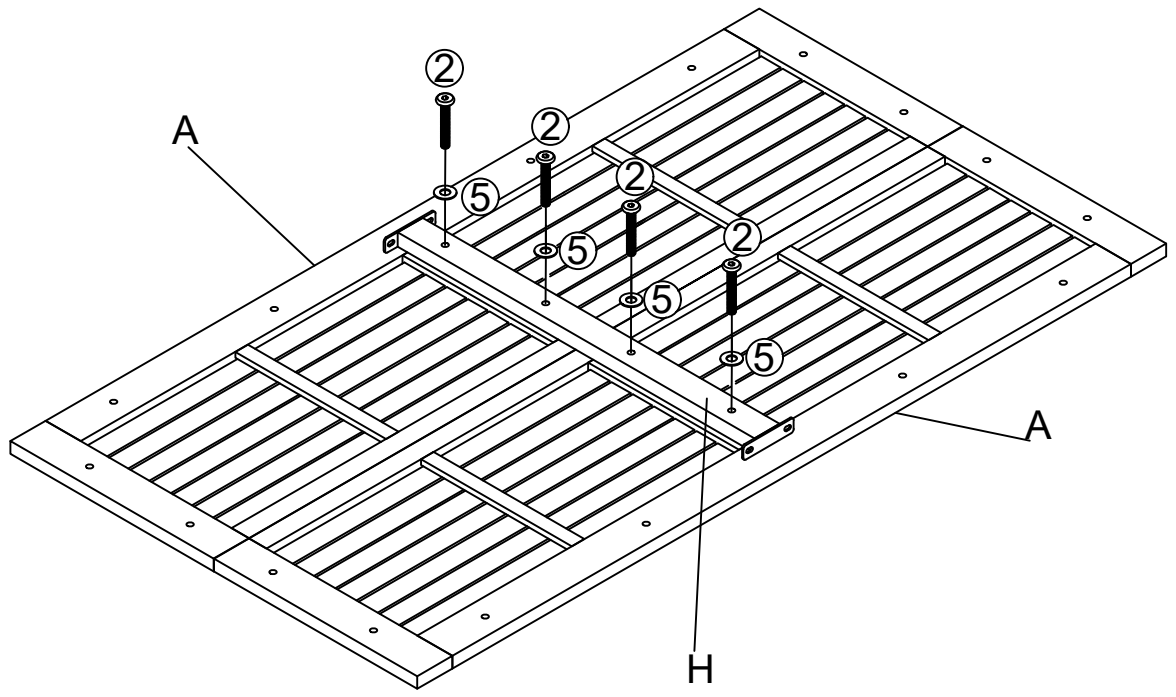

A x2 H x1 ② x4 ⑤ x4

Step 2 x2

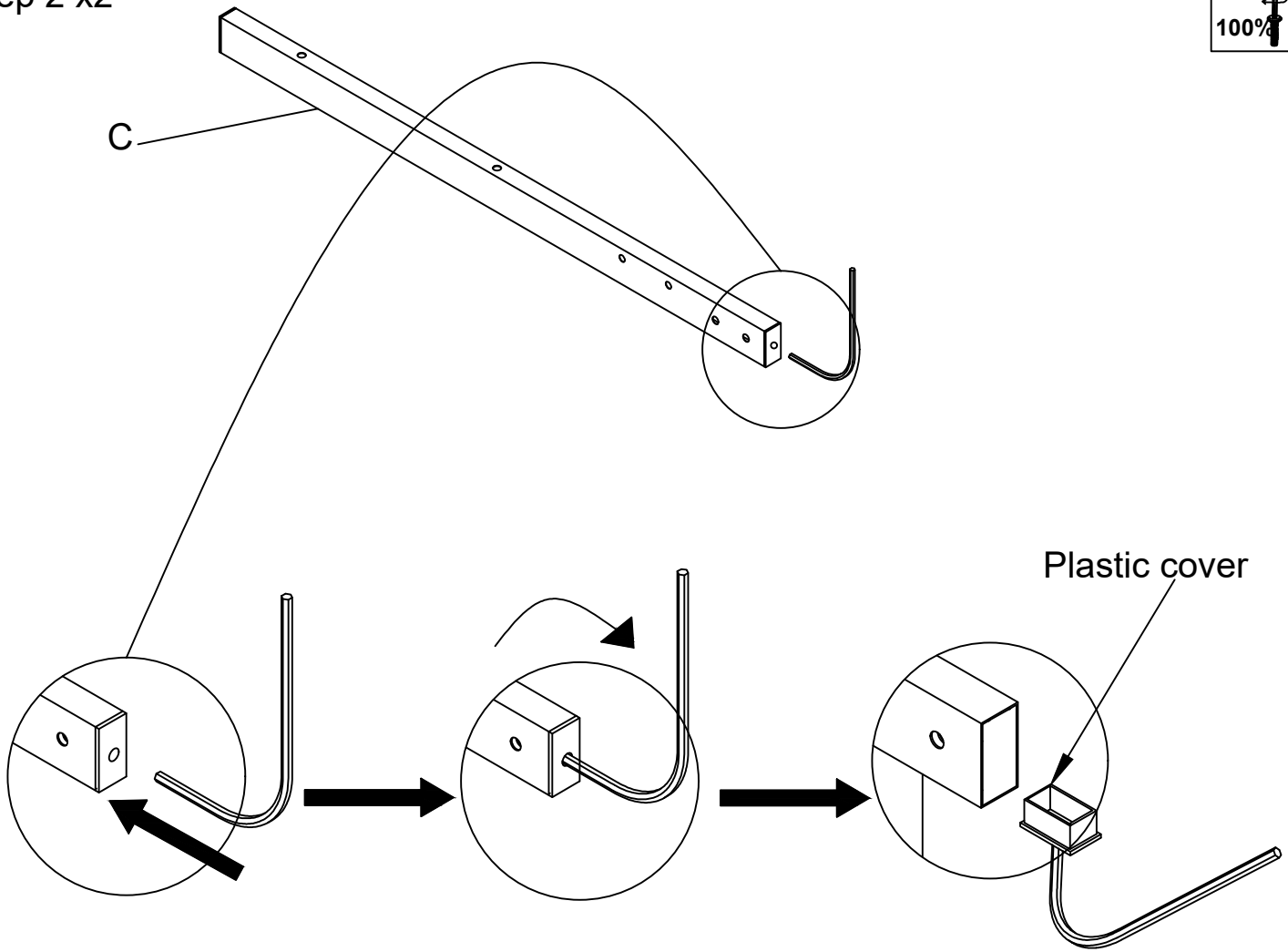

C x2

Step 3 x2

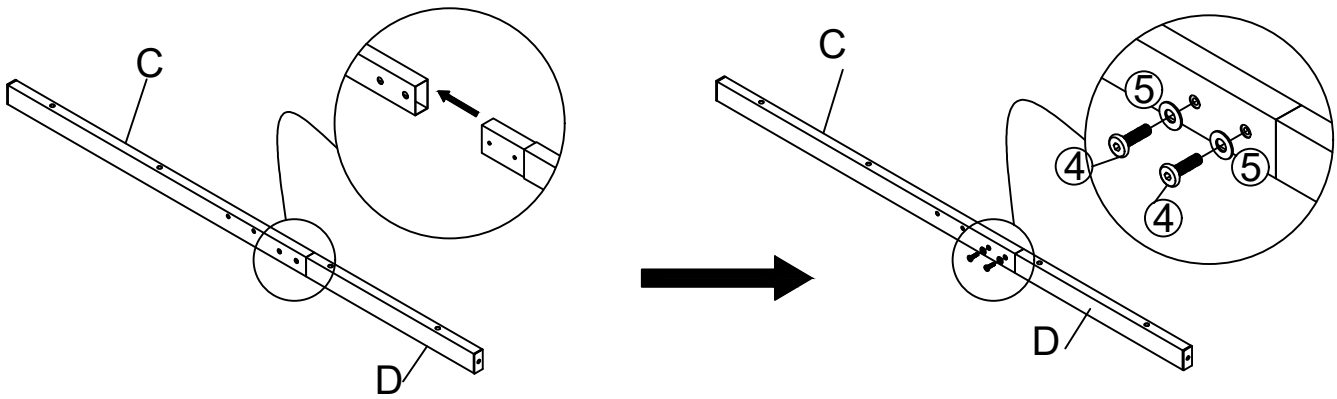

C x1 D x1 ④ x2 ⑤ x2

Step 4

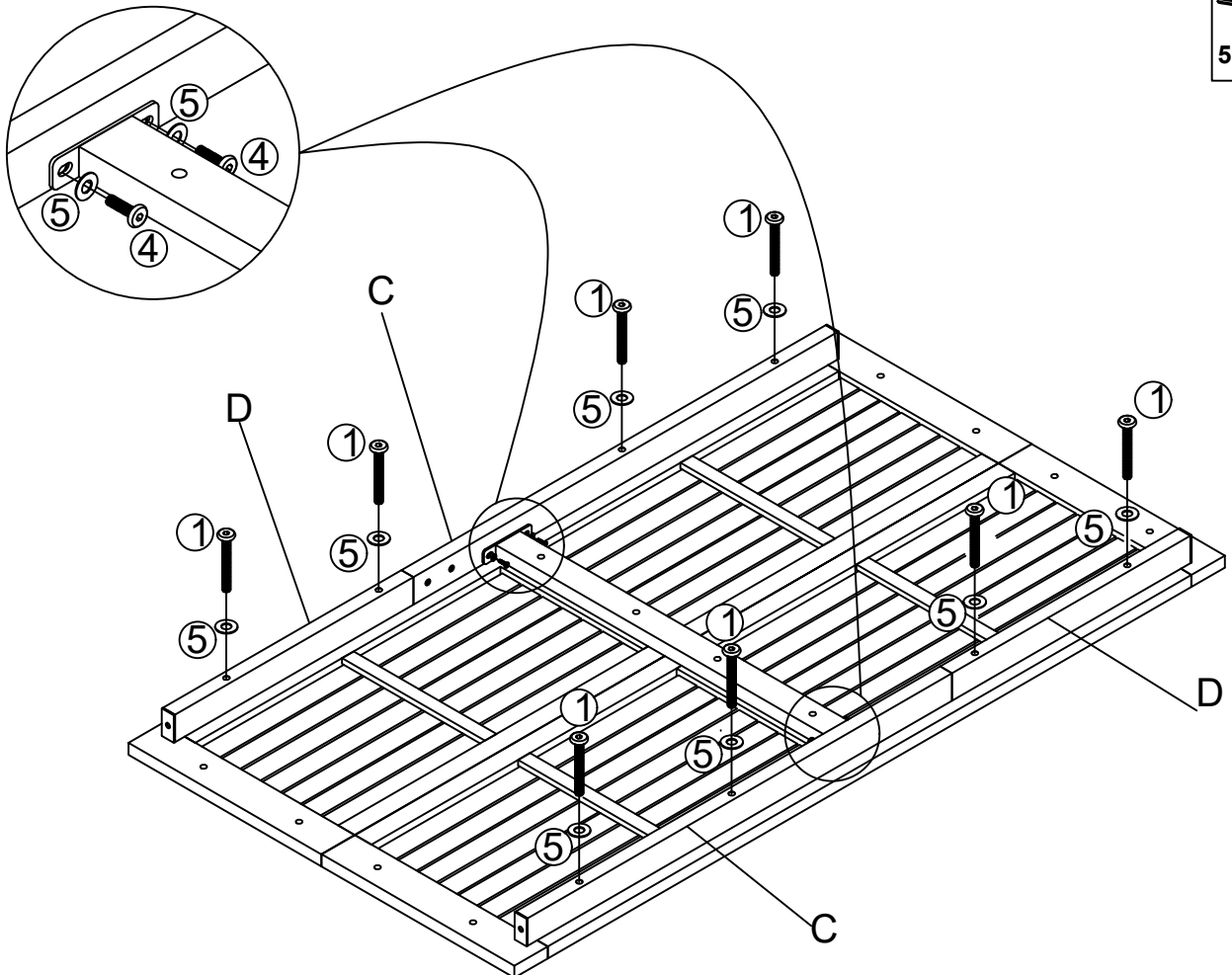

① x8 ④ x4 ⑤ x12

Step 5

Plane with a hole is faced inward

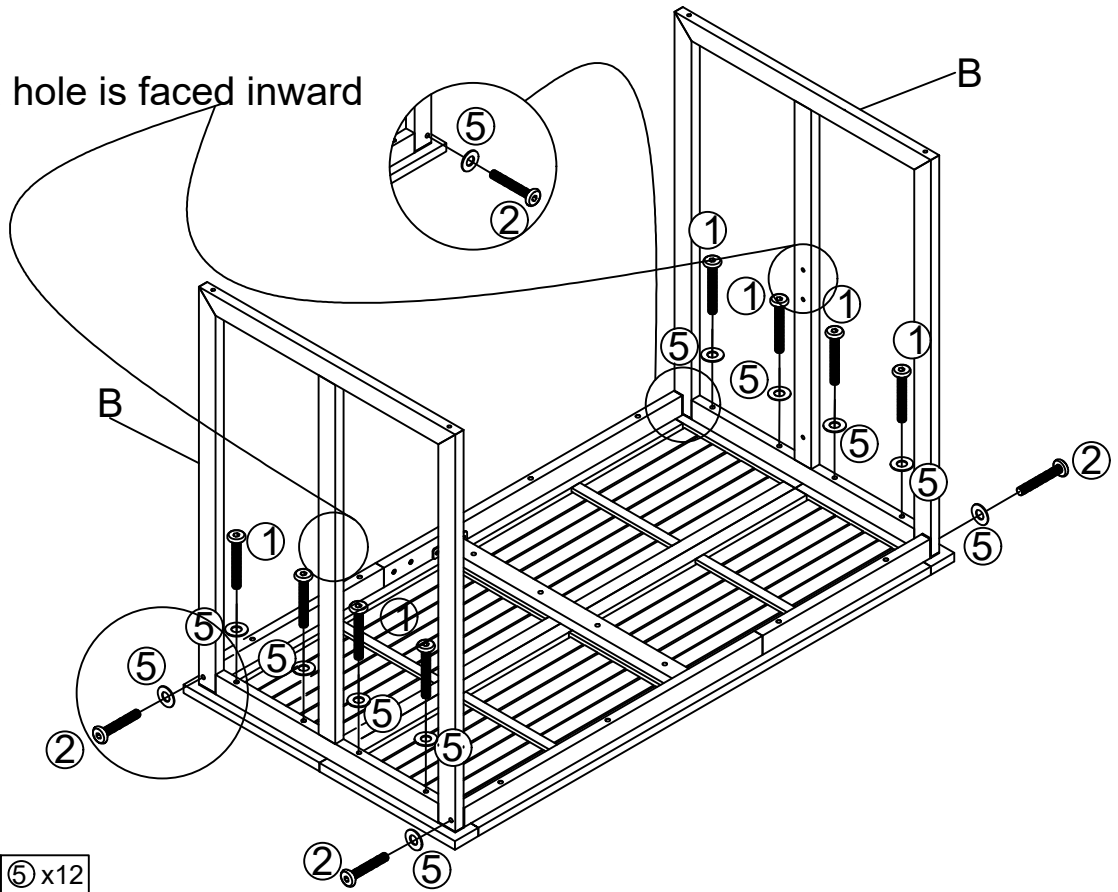

- B x2
- ① x8
- ② x4
- ⑤ x12

Step 6

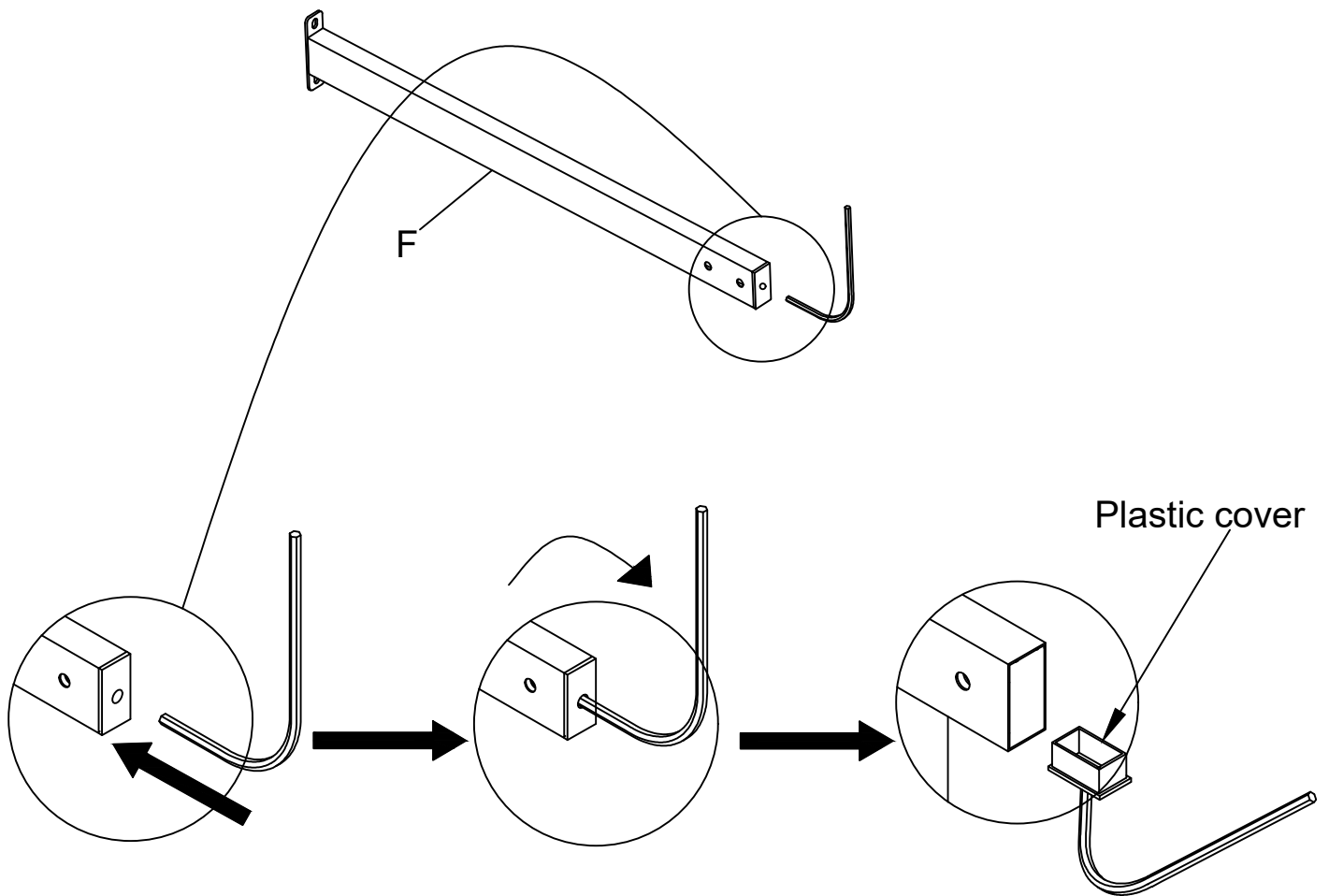

- F x1

Step 7

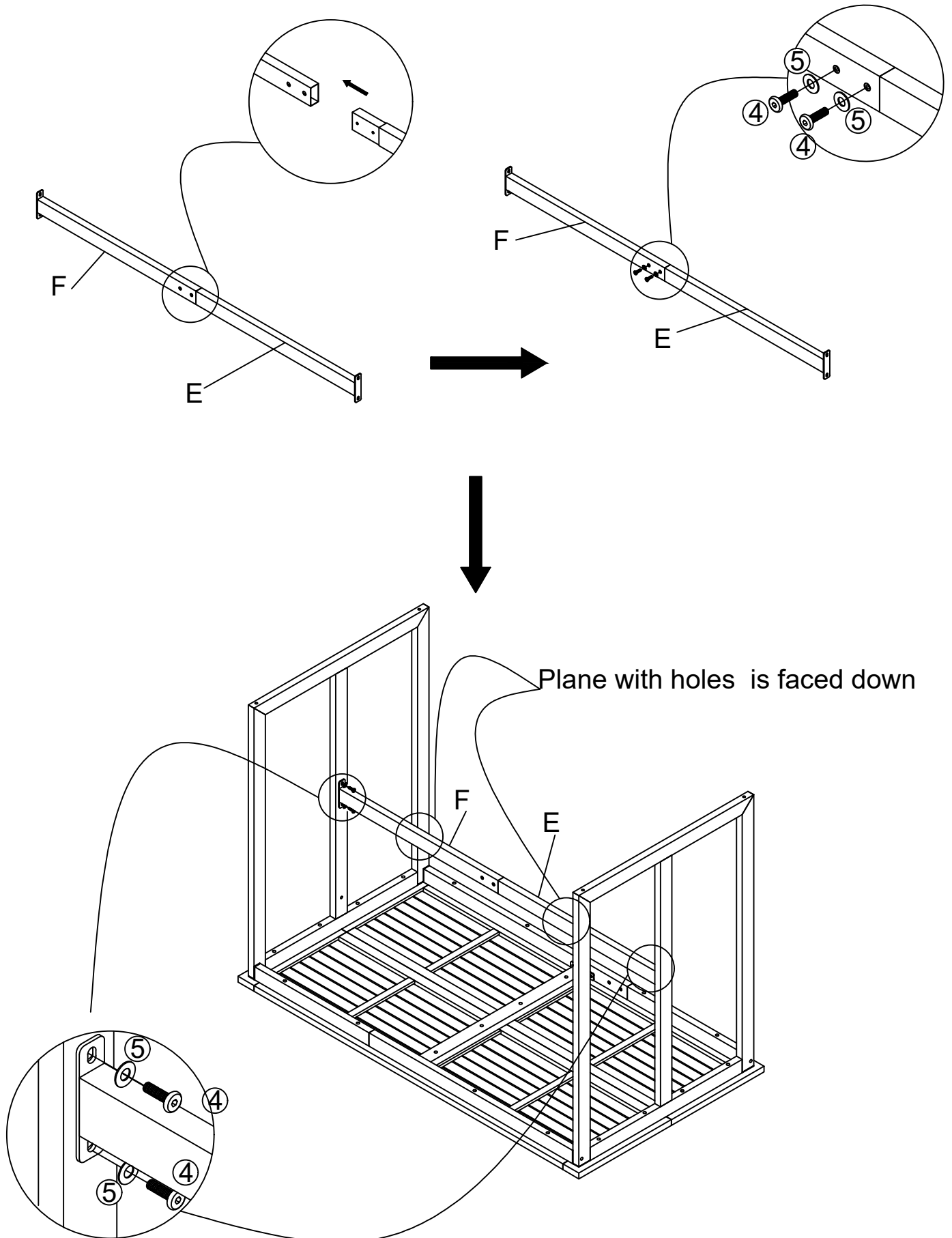

E x1 F x1 ④ x6 ⑤ x6

Step 8

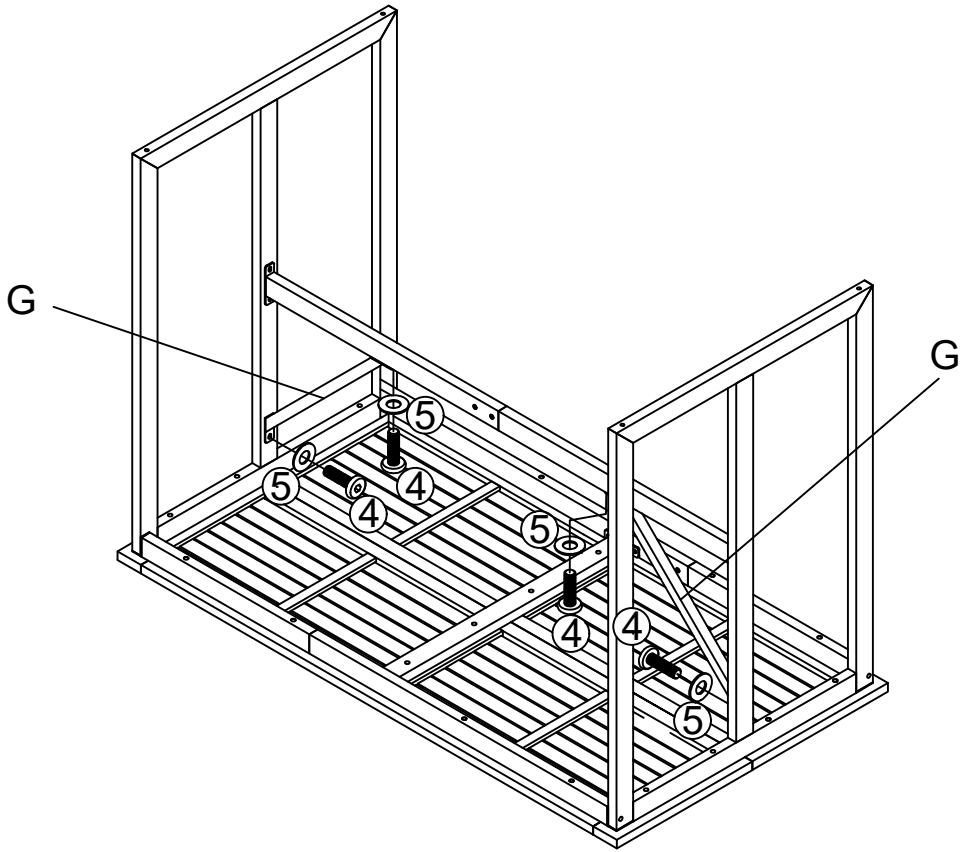

G x2 ④ x4 ⑤ x4

Step 9

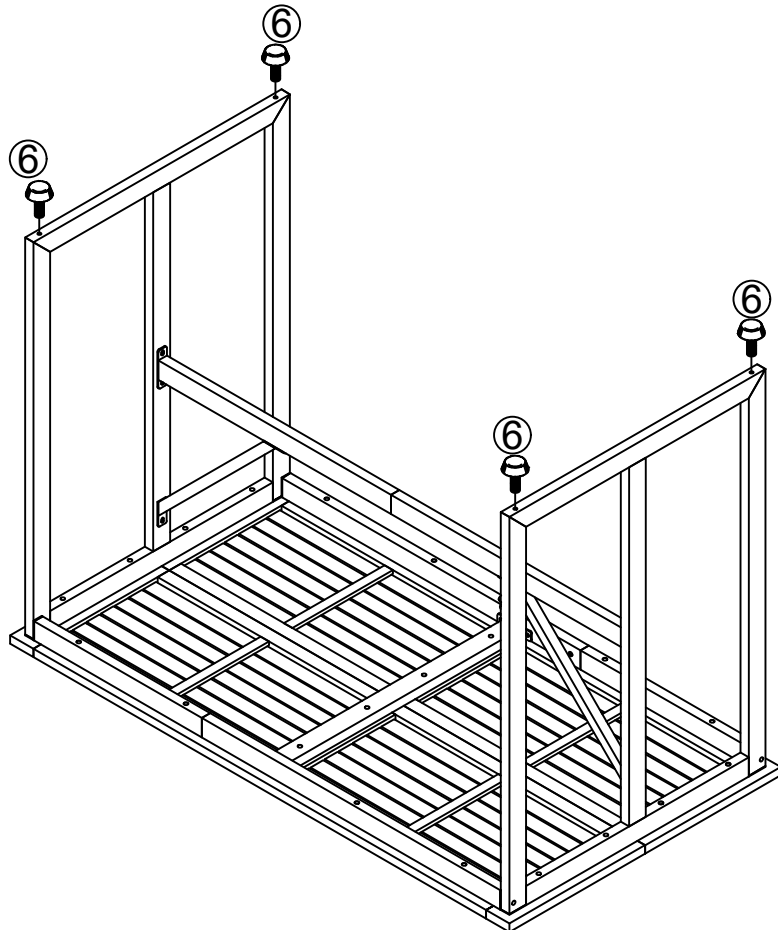

⑥ x4

Step 10

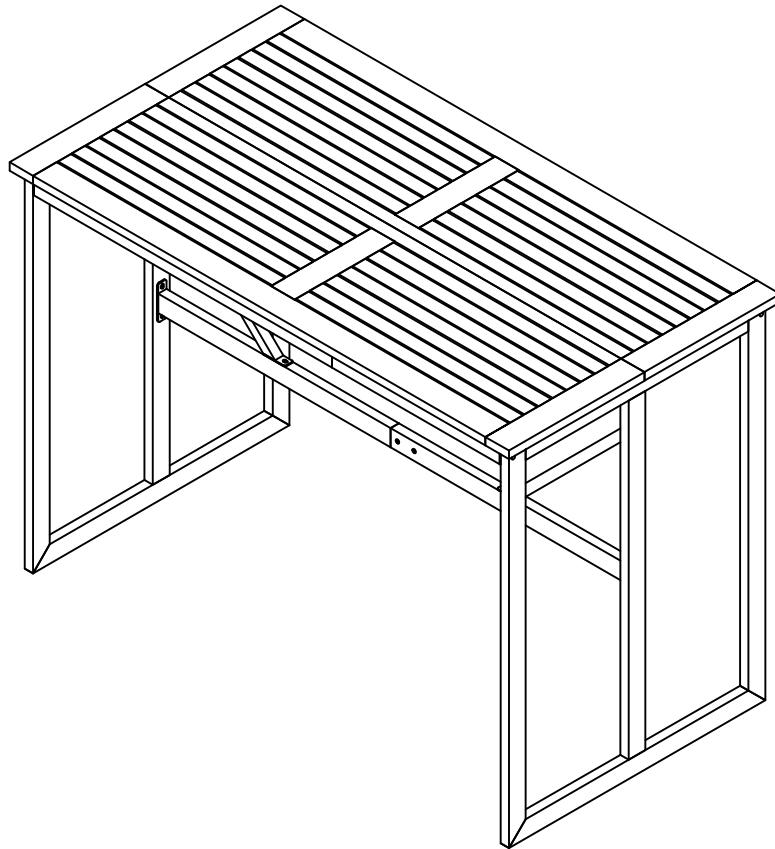

Step 11 x4

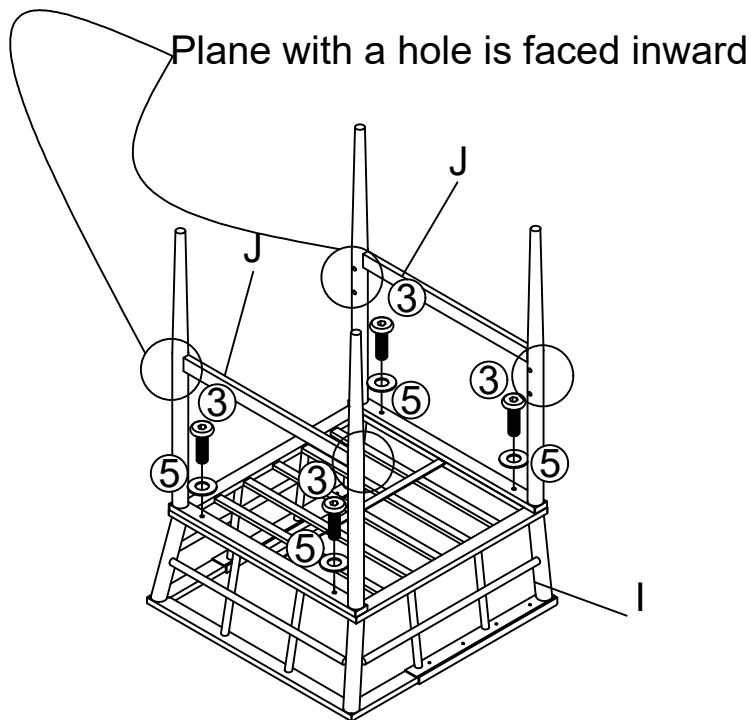

I x1 J x2 ③ x4 ⑤ x4

Step 12 x4

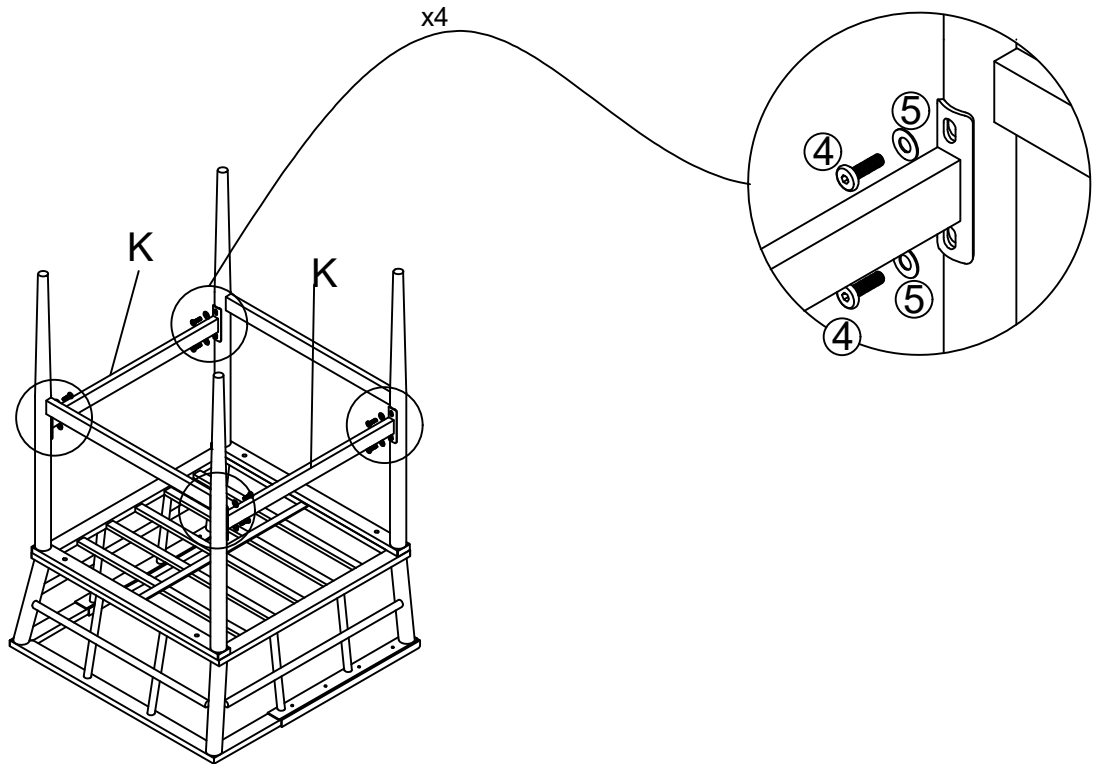

K x2 ④ x8 ⑤ x8

Step 13 x4

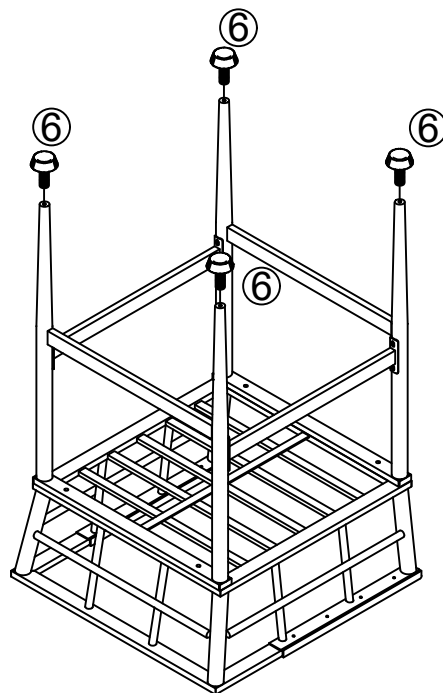

⑥ x4

Step 14 x4

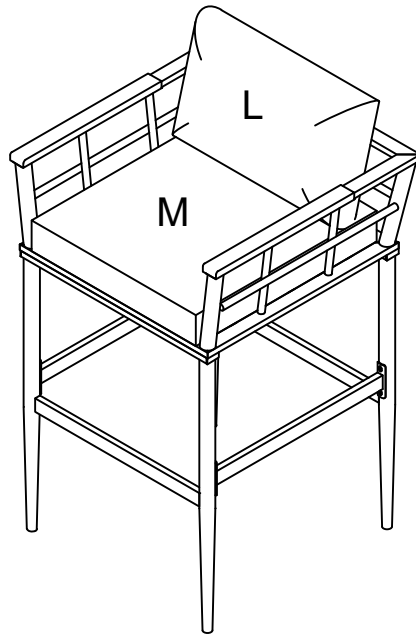

M x1 | L x1

Step 15

