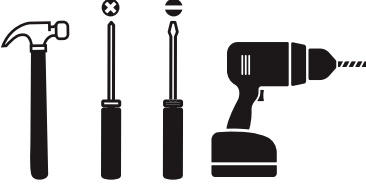

Installation & Assembly

1. Installation precautions

 <p>2 PERS.</p>	 <p>Tools required (not included)</p>
--	--

2. Matters needing attention

Cam Lock Fastening System
Insert the cam bolt into the hole first, then insert the cam lock and lock it.

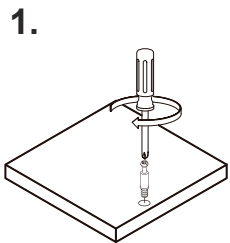
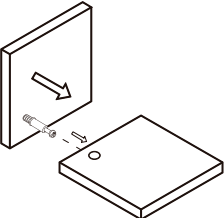
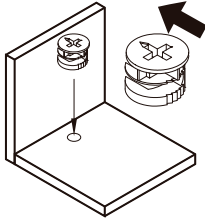
- 
- 
- 

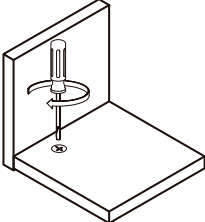
The opening must point toward the edge of the board
- 

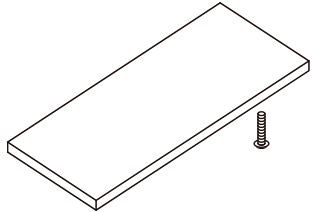
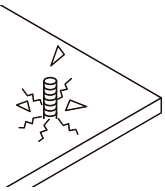
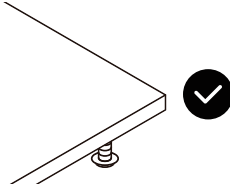
 <p>Be sure to use the proper screws to avoid damaging the parts.</p>	 <p>Wrong screws can cause the plank to crack</p>	 <p>The right screw is the right size</p>
--	--	--

NOTE:

When assembling, please do not fully tighten the screws one by one until all corresponding screws are in the correct position. All parts are numbered for easy assembly. Any questions, please feel free to contact us.

Please check that you have all the parts listed before starting assembly, if you find something missing, please stop the assembly and contact us immediately.

Version:1.0

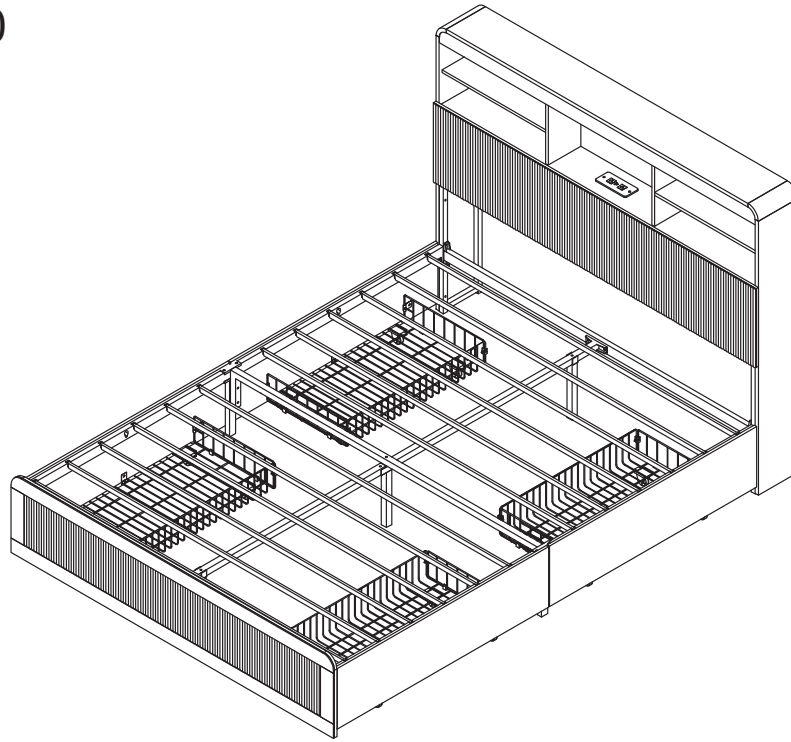

Note:





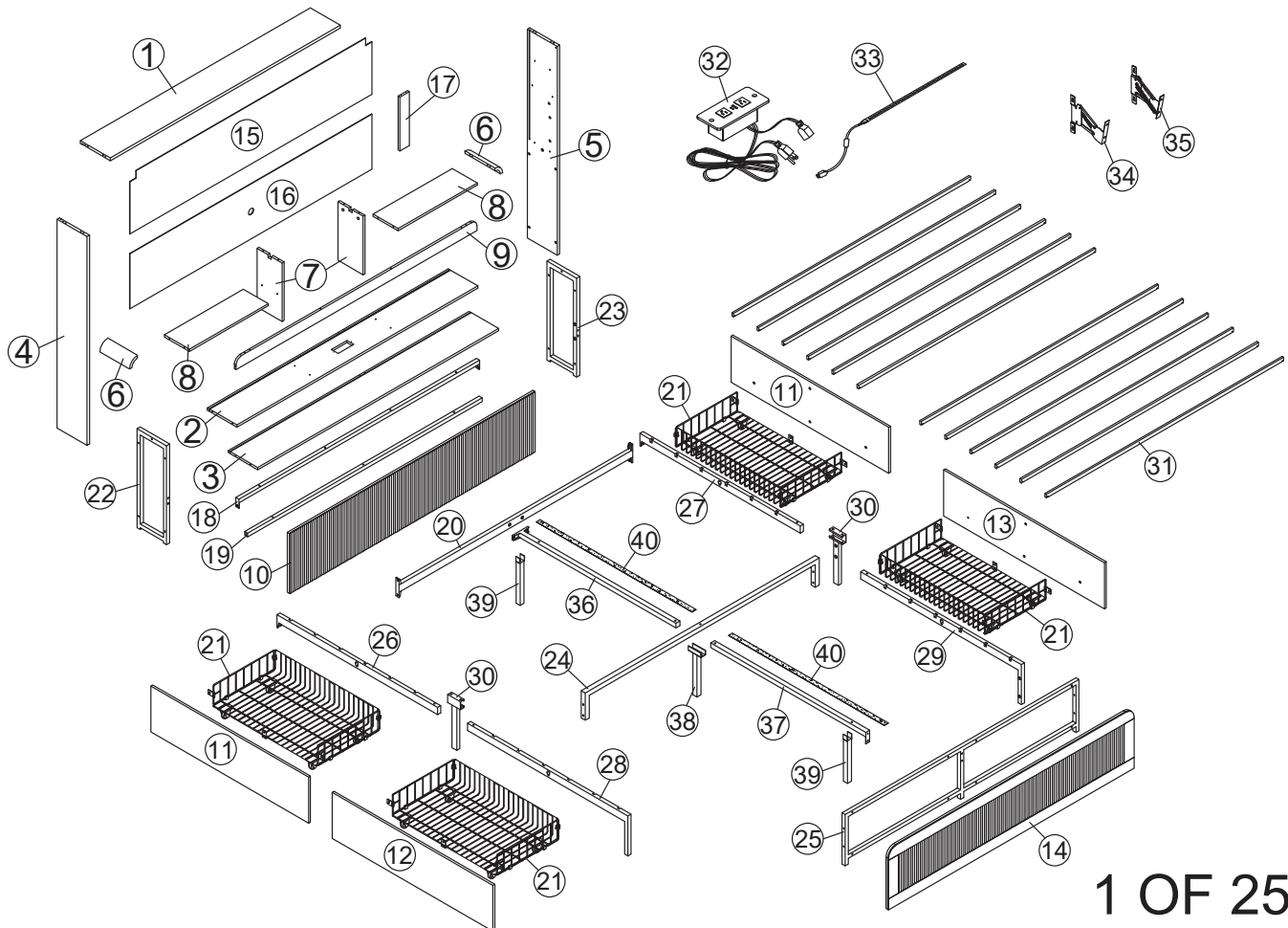

Should be assembled on flat ground to keep balance.

It needs at least two people to install.

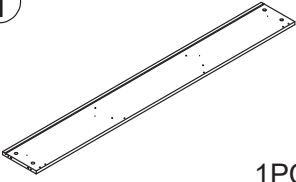
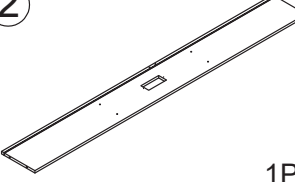
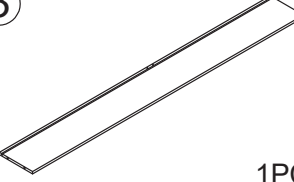

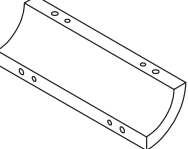
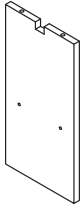
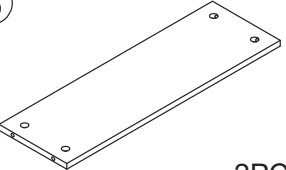
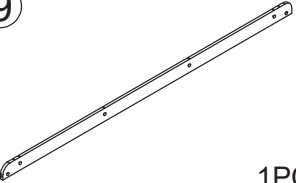
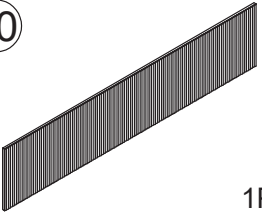
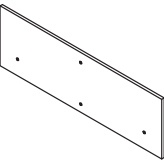
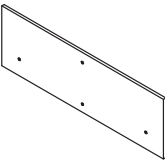
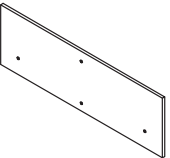
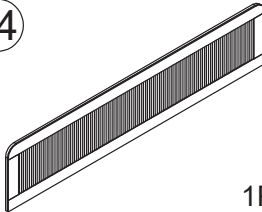
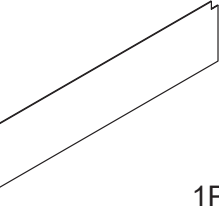
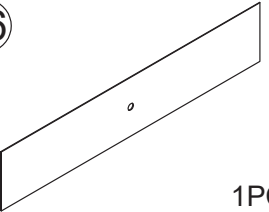
Before starting the assembly, you must read the whole manual and follow the instructions.

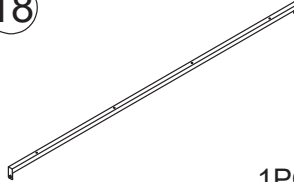
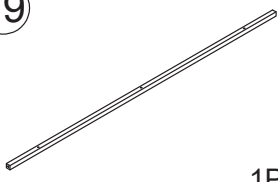
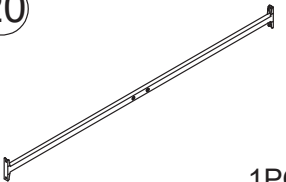
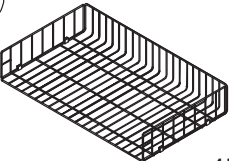

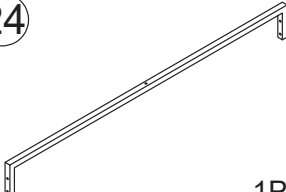
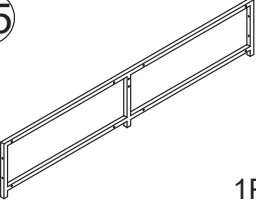
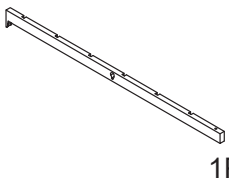
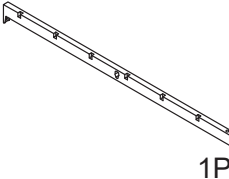
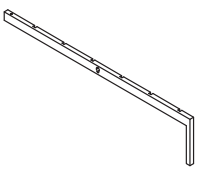
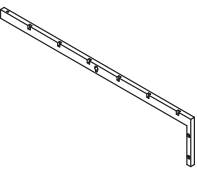
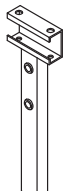
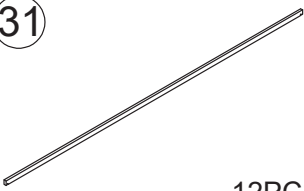
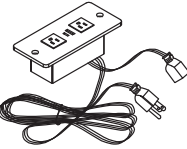



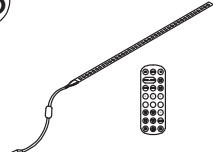
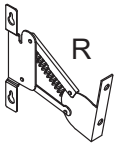
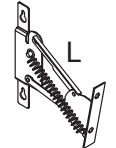
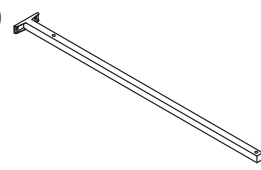
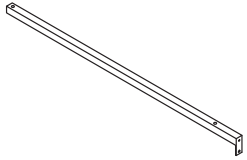
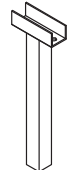

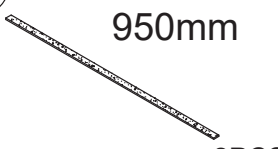



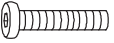

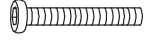





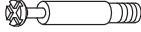



Part list

①  1PC	②  1PC	③  1PC	④  1PC
⑤  1PC	⑥  2PCS	⑦  2PCS	⑧  2PCS
⑨  1PC	⑩  1PC	⑪  2PCS	⑫  1PC
⑬  1PC	⑭  1PC	⑮  1PC	⑯  1PC
⑰  1PC	⑱  1PC	⑲  1PC	⑳  1PC
㉑  4PCS	㉒  1PC	㉓  1PC	㉔  1PC
㉕  1PC	㉖  1PC	㉗  1PC	㉘  1PC
㉙  1PC	㉚  2PCS	㉛  12PCS	㉜  1PC

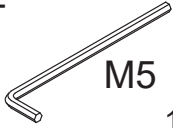

Part list

<p>33</p>  <p>1PC</p>	<p>34</p>  <p>1PC</p>	<p>35</p>  <p>1PC</p>	<p>36</p>  <p>1PC</p>
<p>37</p>  <p>1PC</p>	<p>38</p>  <p>1PC</p>	<p>39</p>  <p>2PCS</p>	<p>40</p> <p>950mm</p>  <p>2PCS</p>

Hardware list

<p>A M6x40</p>  <p>5+1PCS</p>	<p>B M8x16</p>  <p>6+1PCS</p>	<p>C M8x55</p>  <p>5+1PCS</p>	<p>D M6x18</p>  <p>3+1PCS</p>	<p>E M6x20</p>  <p>3+1PCS</p>
<p>F M8x35</p>  <p>12+1PCS</p>	<p>G M6x28</p>  <p>23+2PCS</p>	<p>H M5x40</p>  <p>8+1PCS</p>	<p>I</p>  <p>4+1PC</p>	<p>J</p>  <p>34+3PCS</p>
<p>K</p>  <p>34+3PCS</p>	<p>L M3.5x12</p>  <p>18+1PCS</p>	<p>M</p>  <p>24+4PCS</p>	<p>N</p>  <p>16PCS</p>	<p>O</p>  <p>8PCS</p>
<p>P</p>  <p>12PCS</p>	<p>Q M6x10</p>  <p>22+2PCS</p>	<p>R</p>  <p>4PCS</p>	<p>S</p> <p>M4</p>  <p>2PCS</p>	<p>T</p> <p>M5</p>  <p>1PC</p>
<p>U M6x30</p>  <p>10+1PCS</p>	<p>V</p> <p>M4</p>  <p>1PC</p>	<p>W</p>  <p>12+1PCS</p>		

Step 1

A		M6x40	2PCS
S		M4	1PC

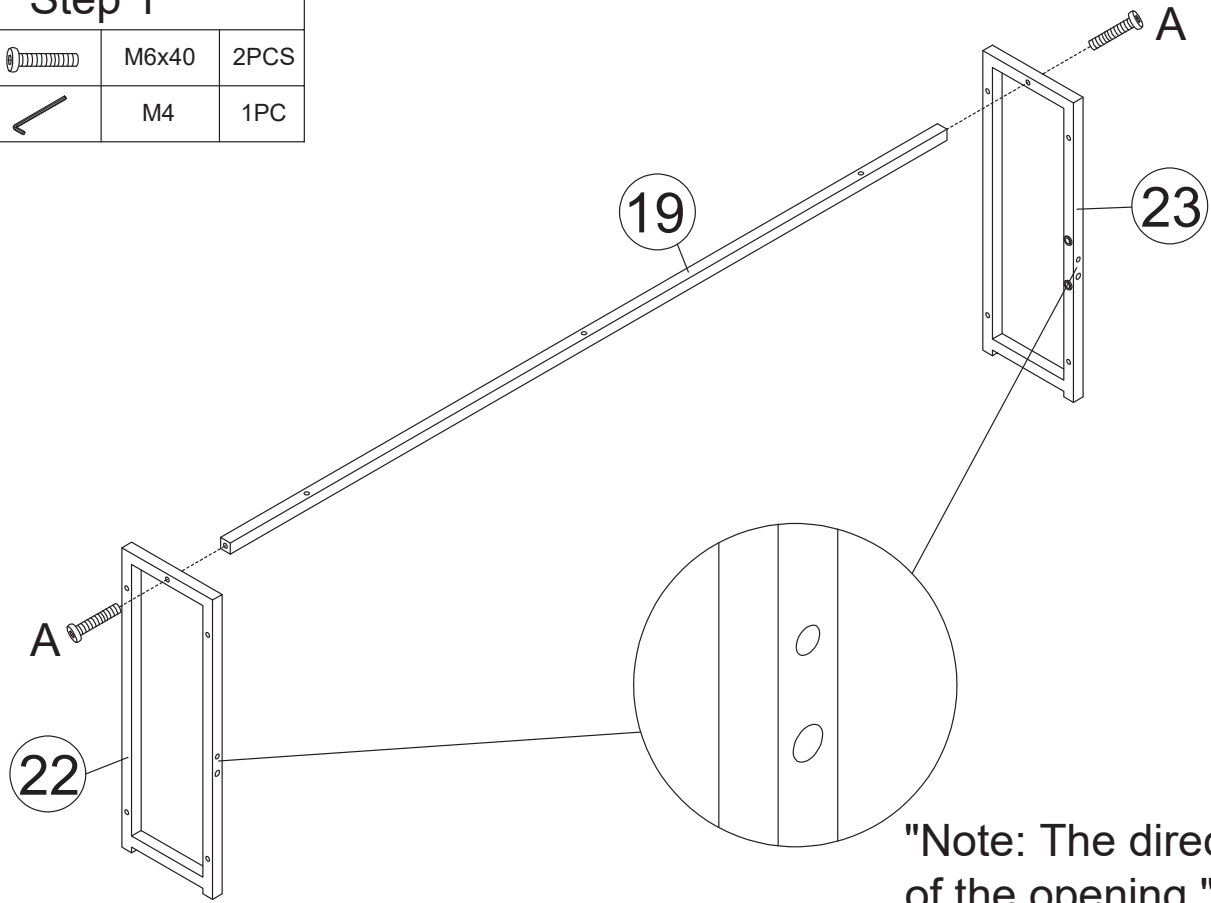



"Note: The direction of the opening."

Step 2

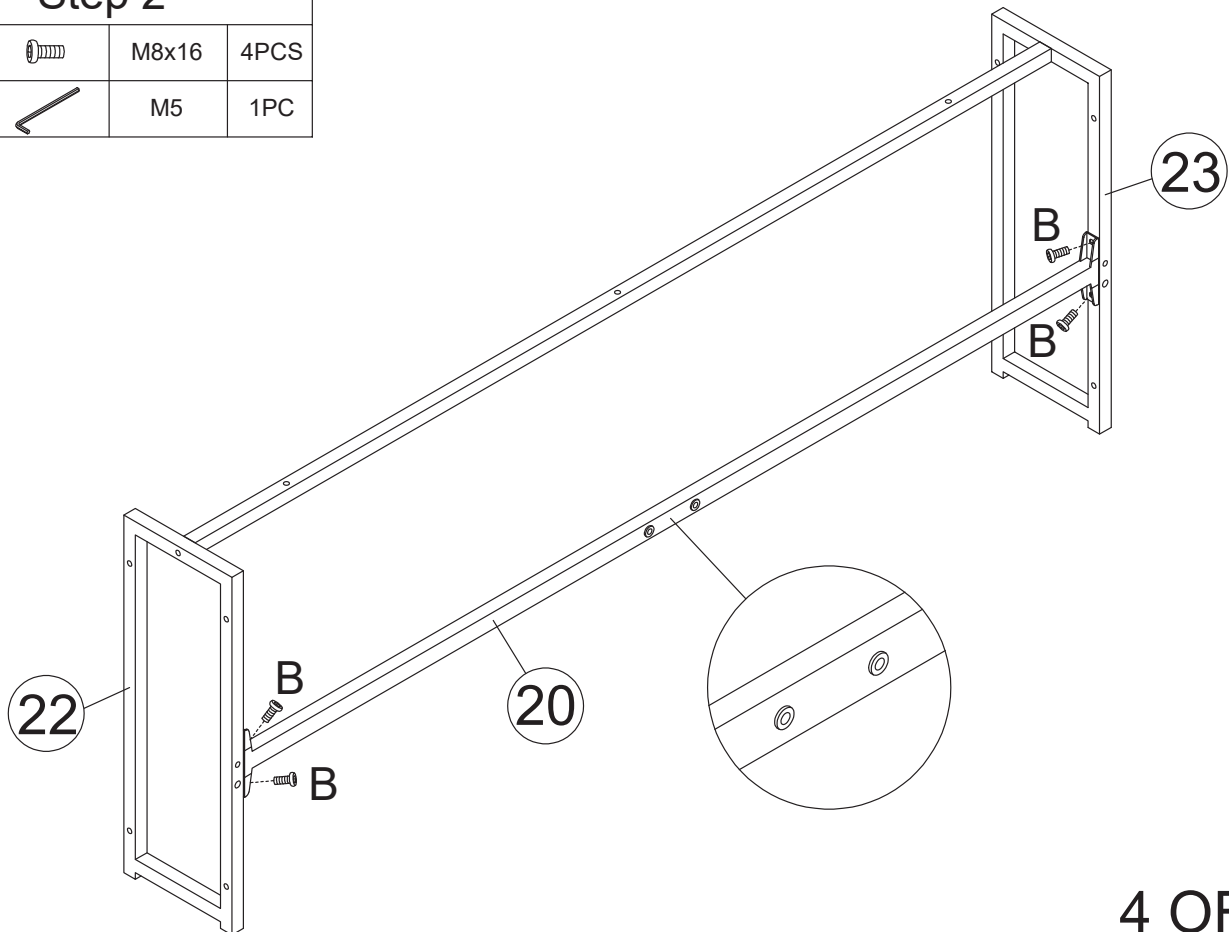
B		M8x16	4PCS
T		M5	1PC



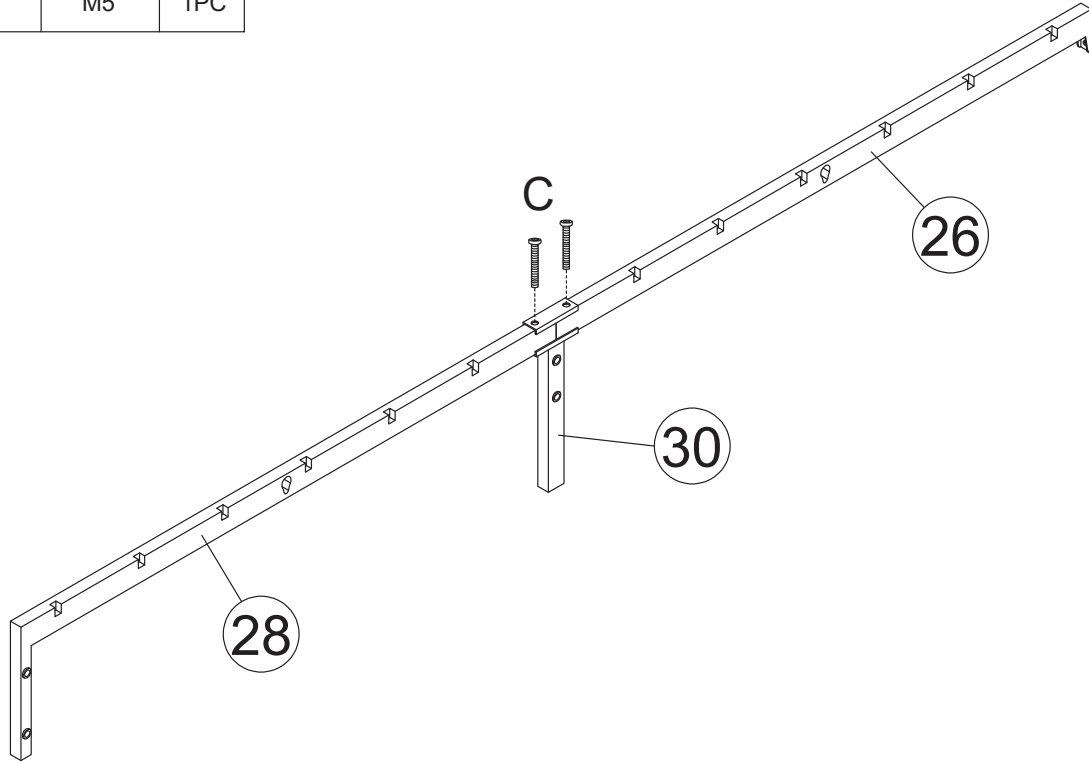

Step 3

C		M8x55	2PCS
T		M5	1PC





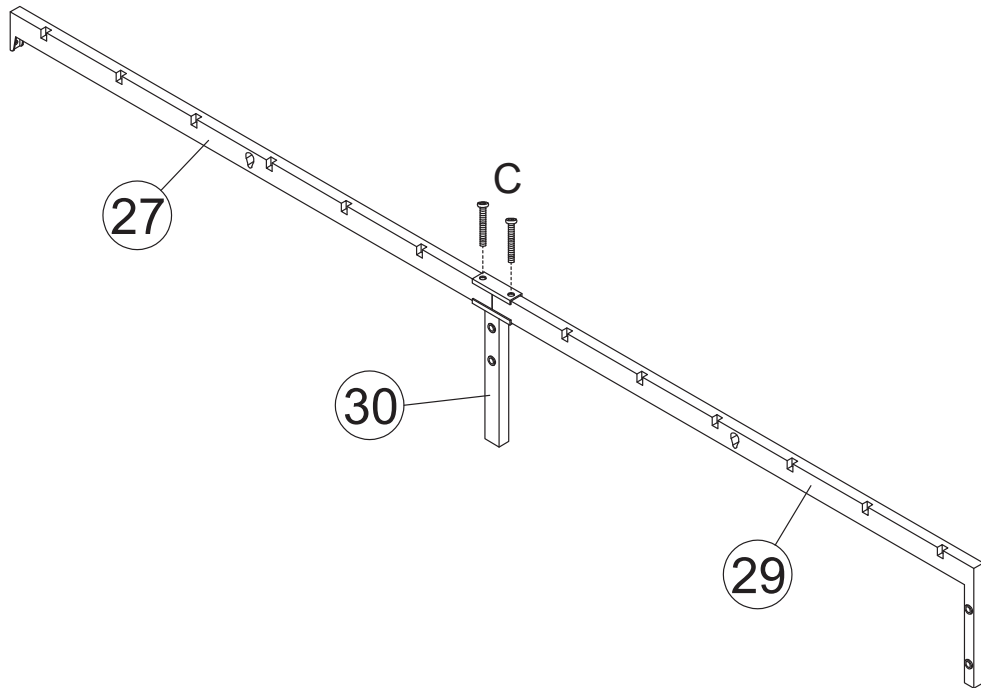

Step 4

C		M8x55	2PCS
T		M5	1PC





Step 5

A		M6x40	2PCS
D		M6x18	2PCS
E		M6x20	2PCS
S		M4	2PCS

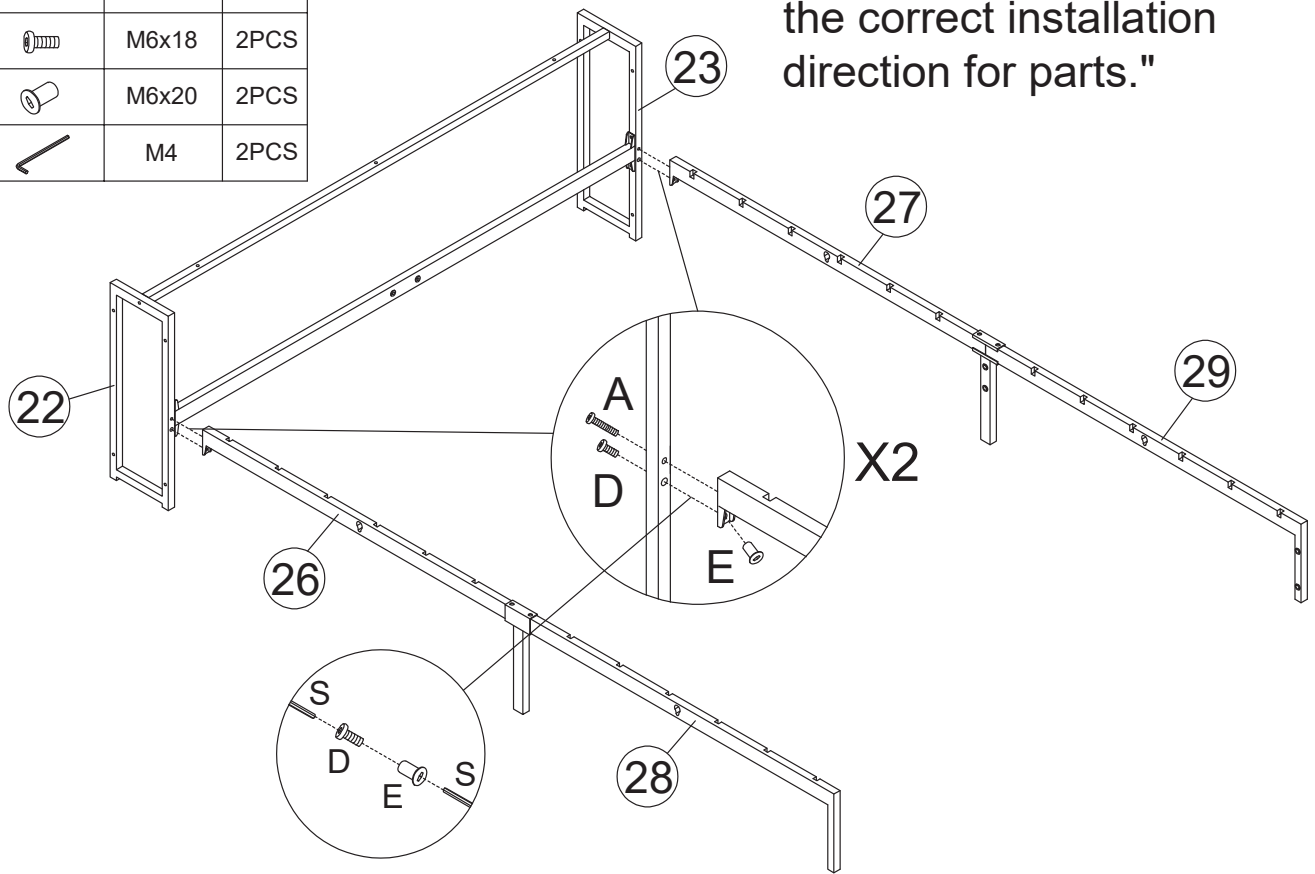
"Note: Make sure to follow the correct installation direction for parts."



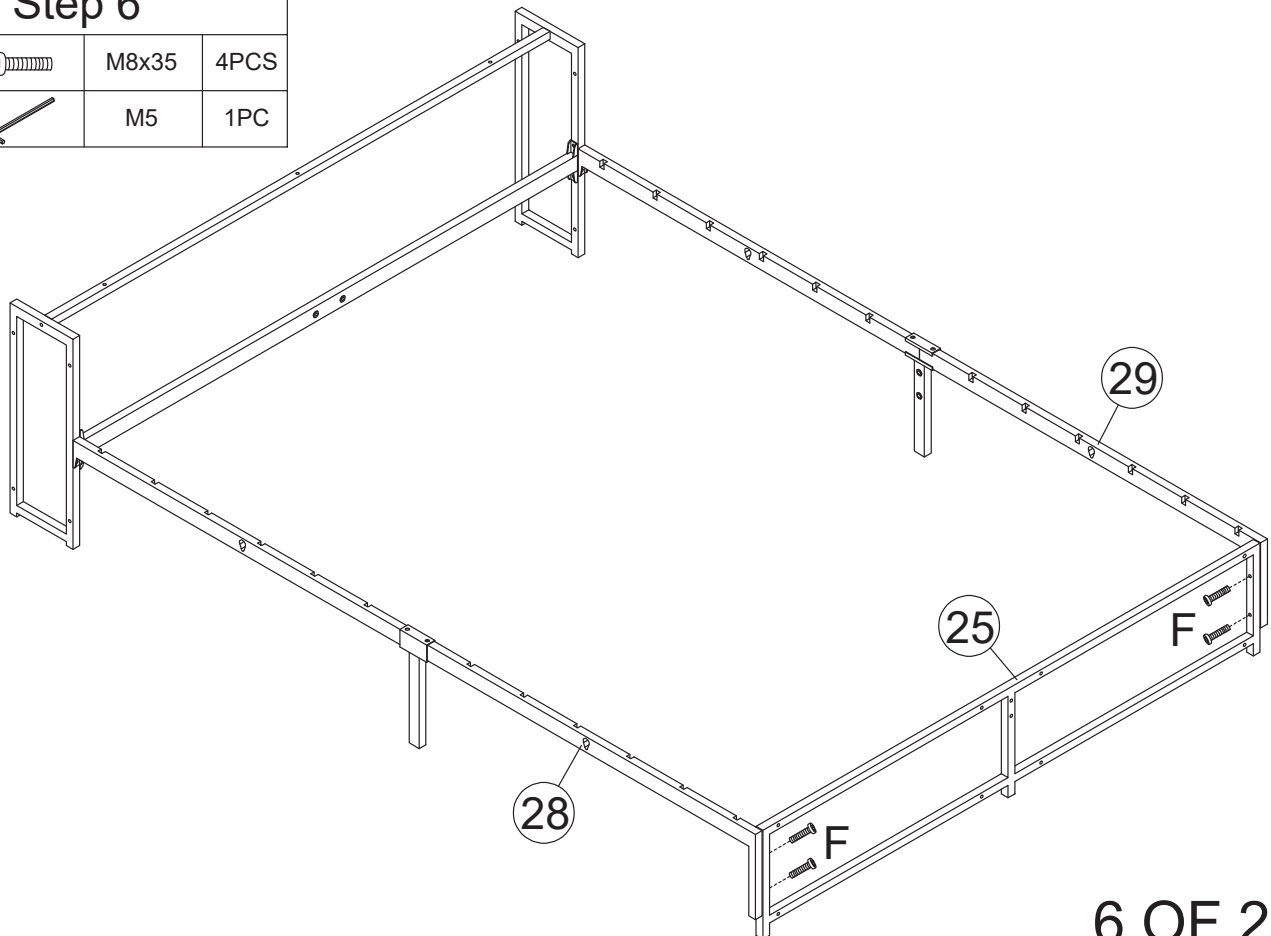

Step 6

F		M8x35	4PCS
T		M5	1PC



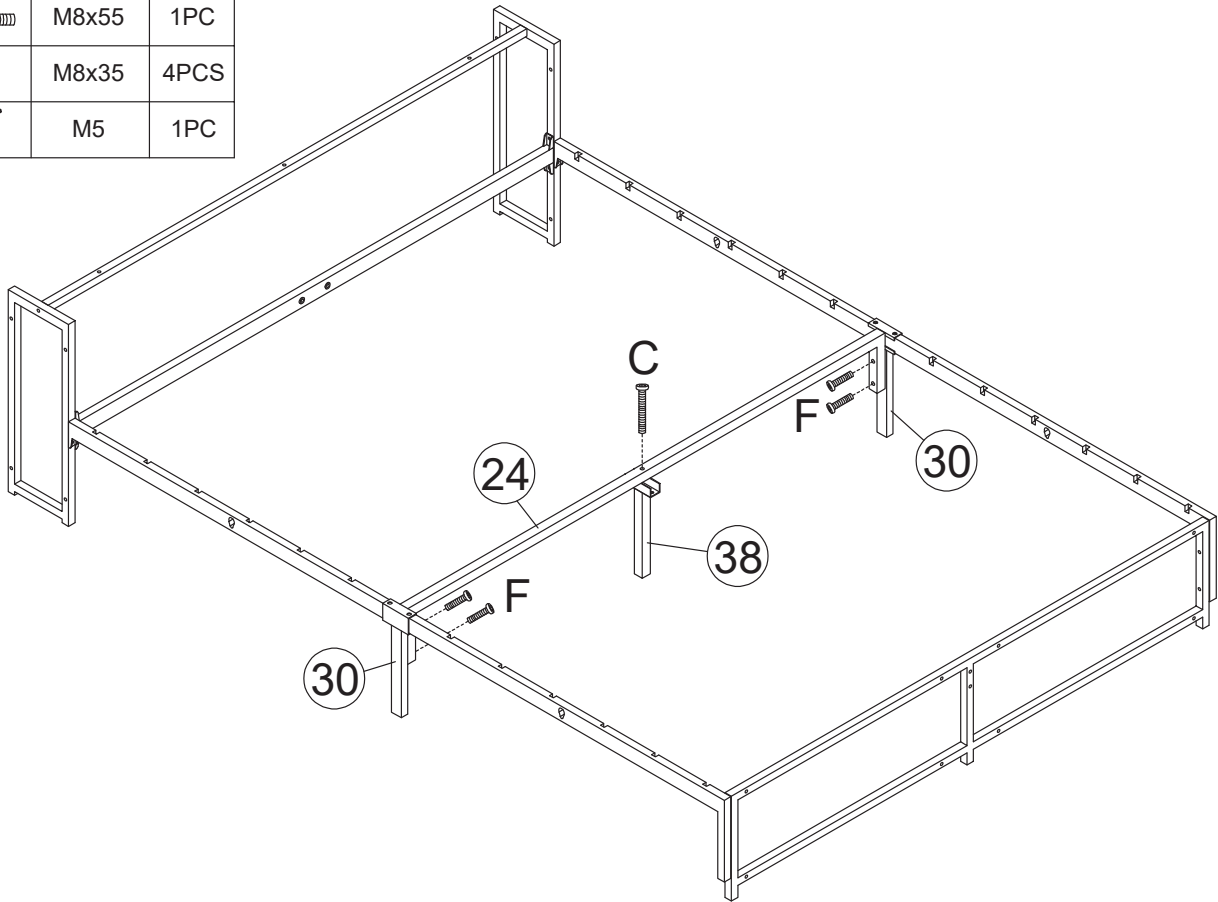

Step 7

C		M8x55	1PC
F		M8x35	4PCS
T		M5	1PC







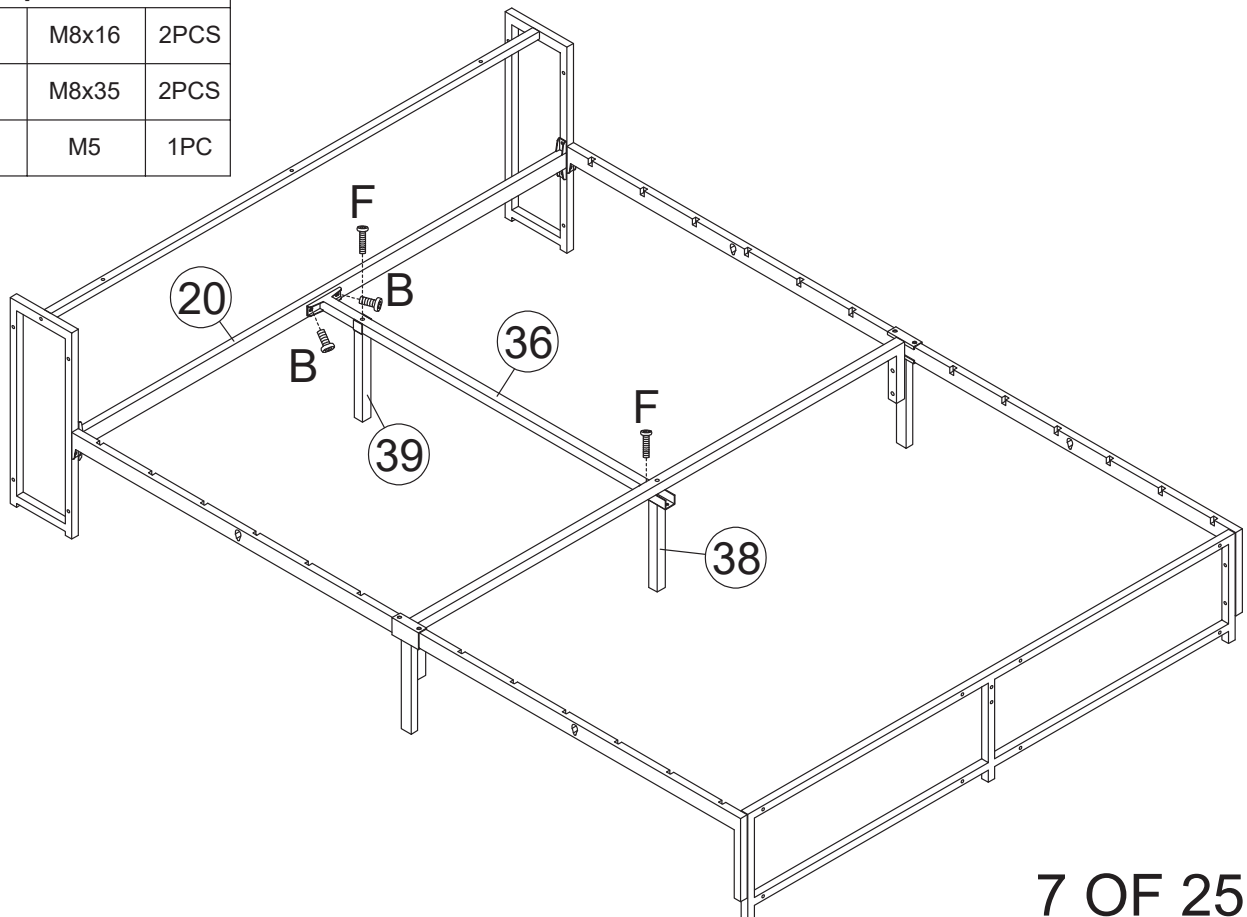

Step 8

B		M8x16	2PCS
F		M8x35	2PCS
T		M5	1PC



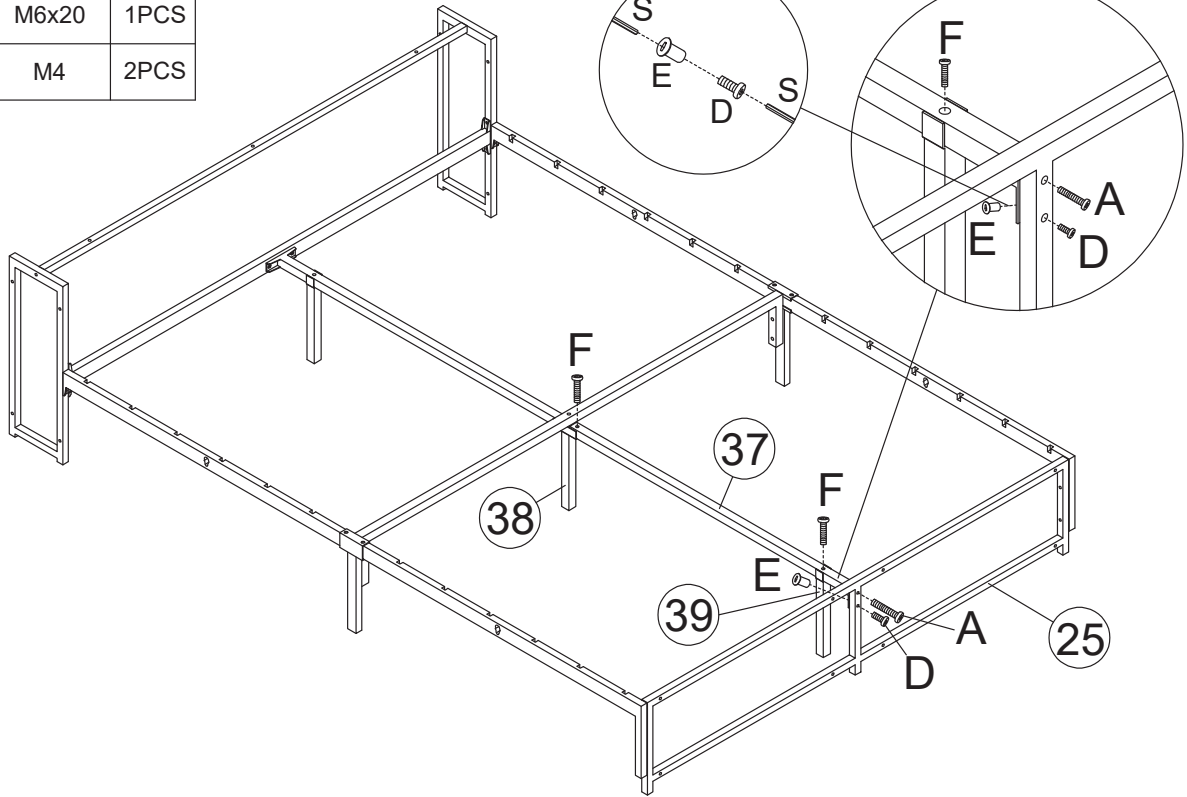

Step 9

A		M6x40	1PCS	F		M8x35	2PCS
D		M6x18	1PCS	T		M5	1PC
E		M6x20	1PCS				
S		M4	2PCS				



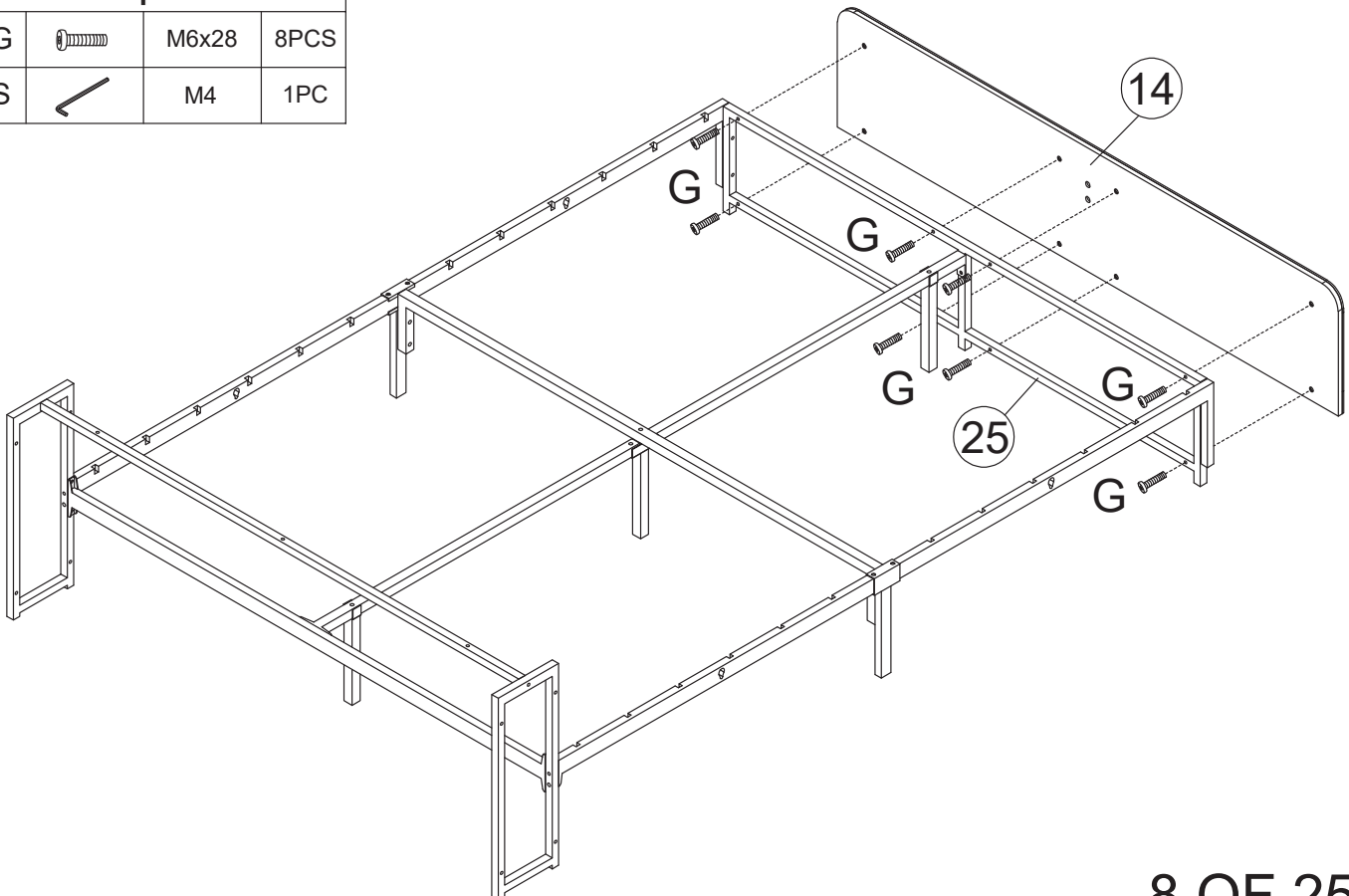

Step 10

G		M6x28	8PCS
S		M4	1PC



Step 11

J			4PCS
V		M4	1PC

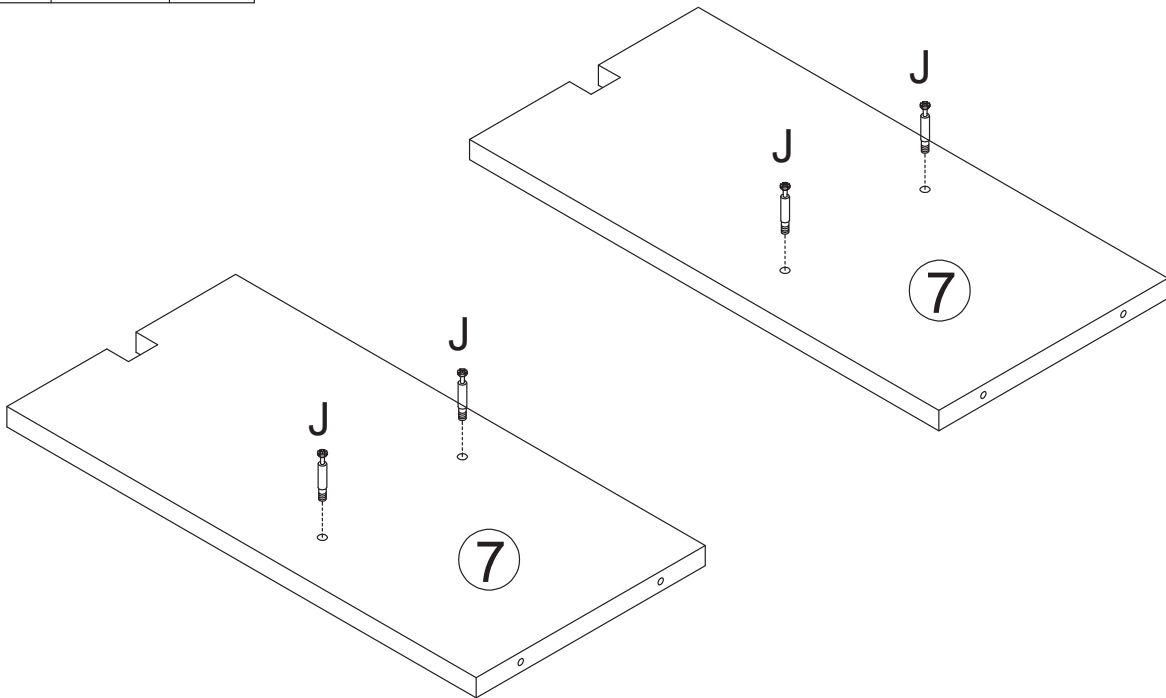

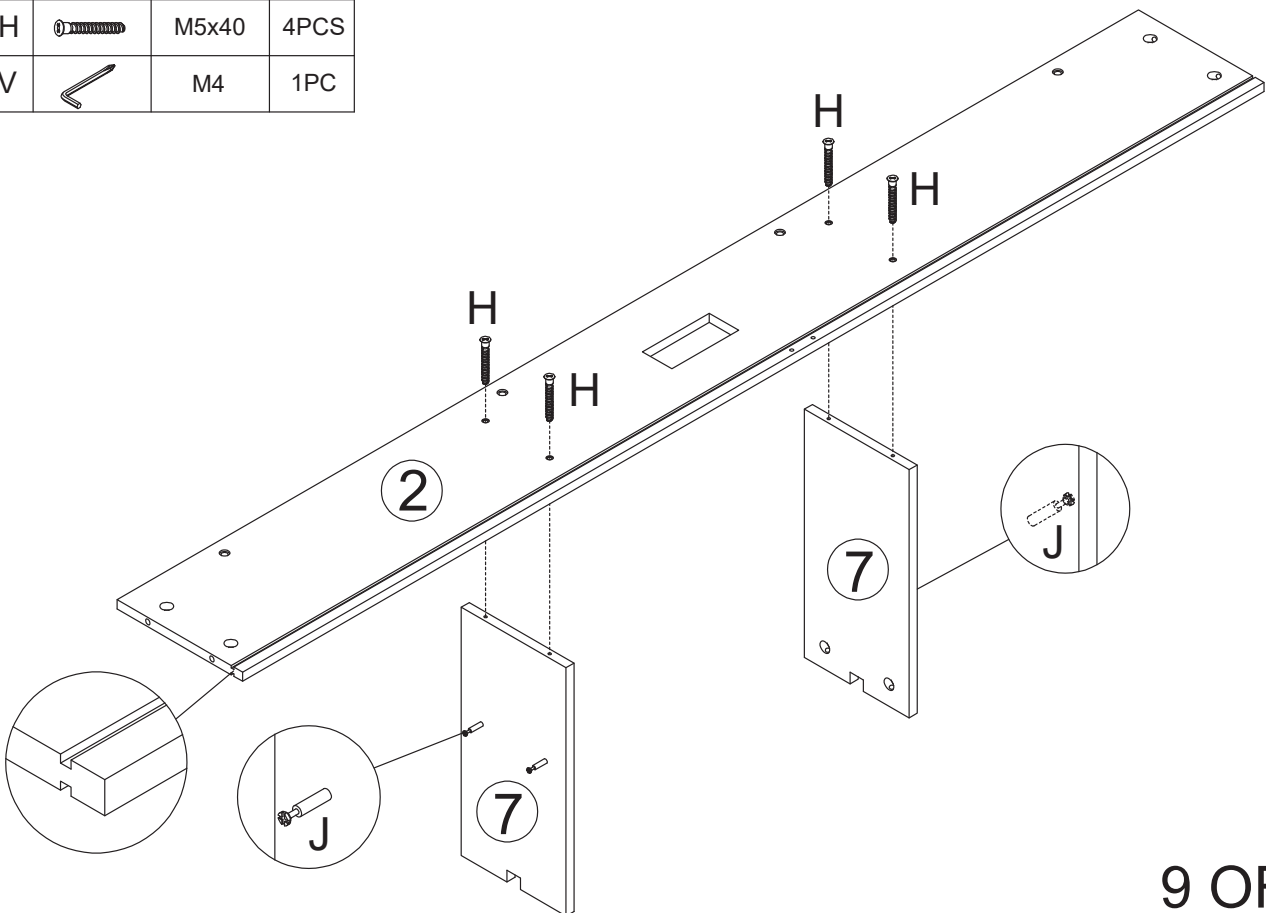

Step 12

H		M5x40	4PCS
V		M4	1PC



Step 13

G		M6x28	4PCS
S		M4	1PC

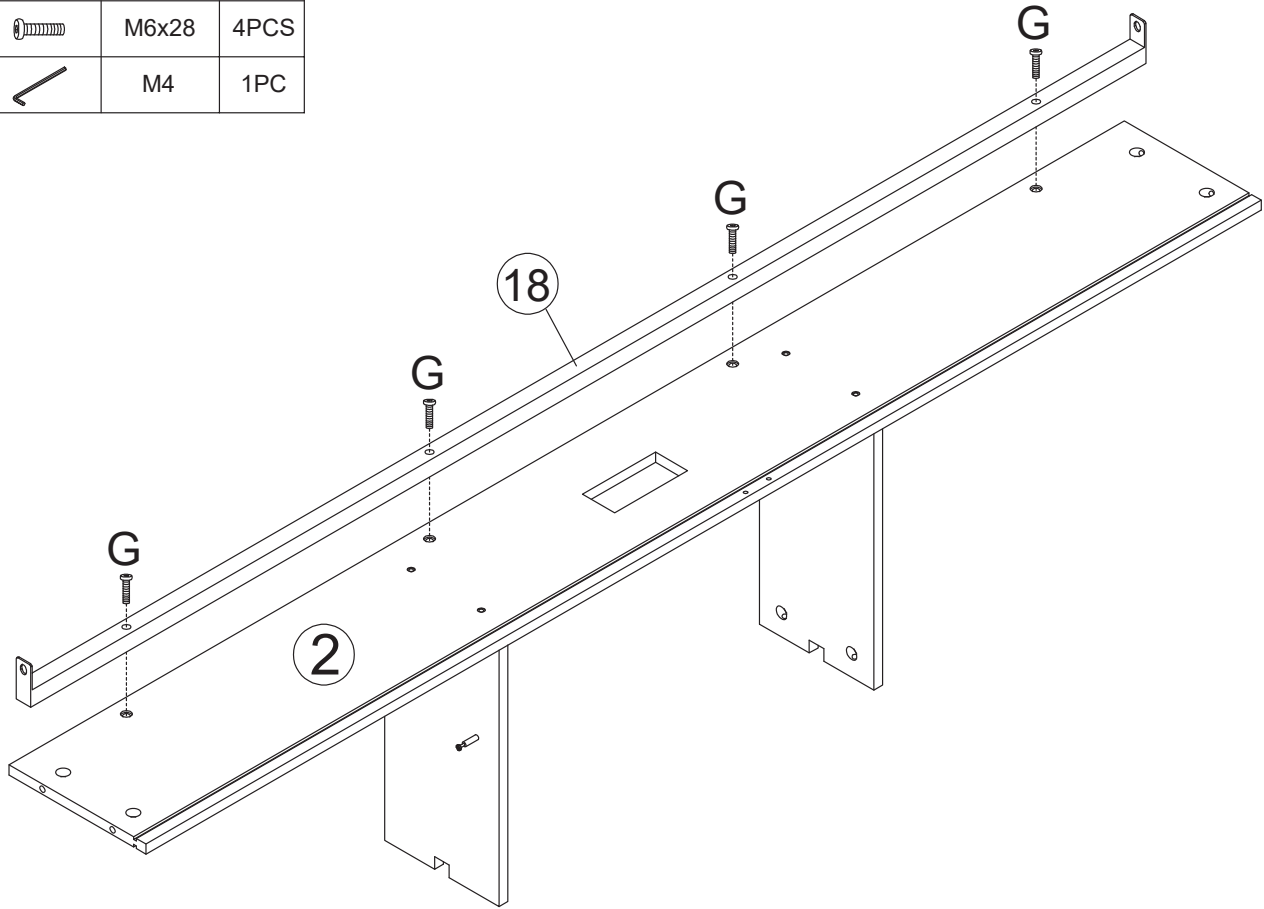

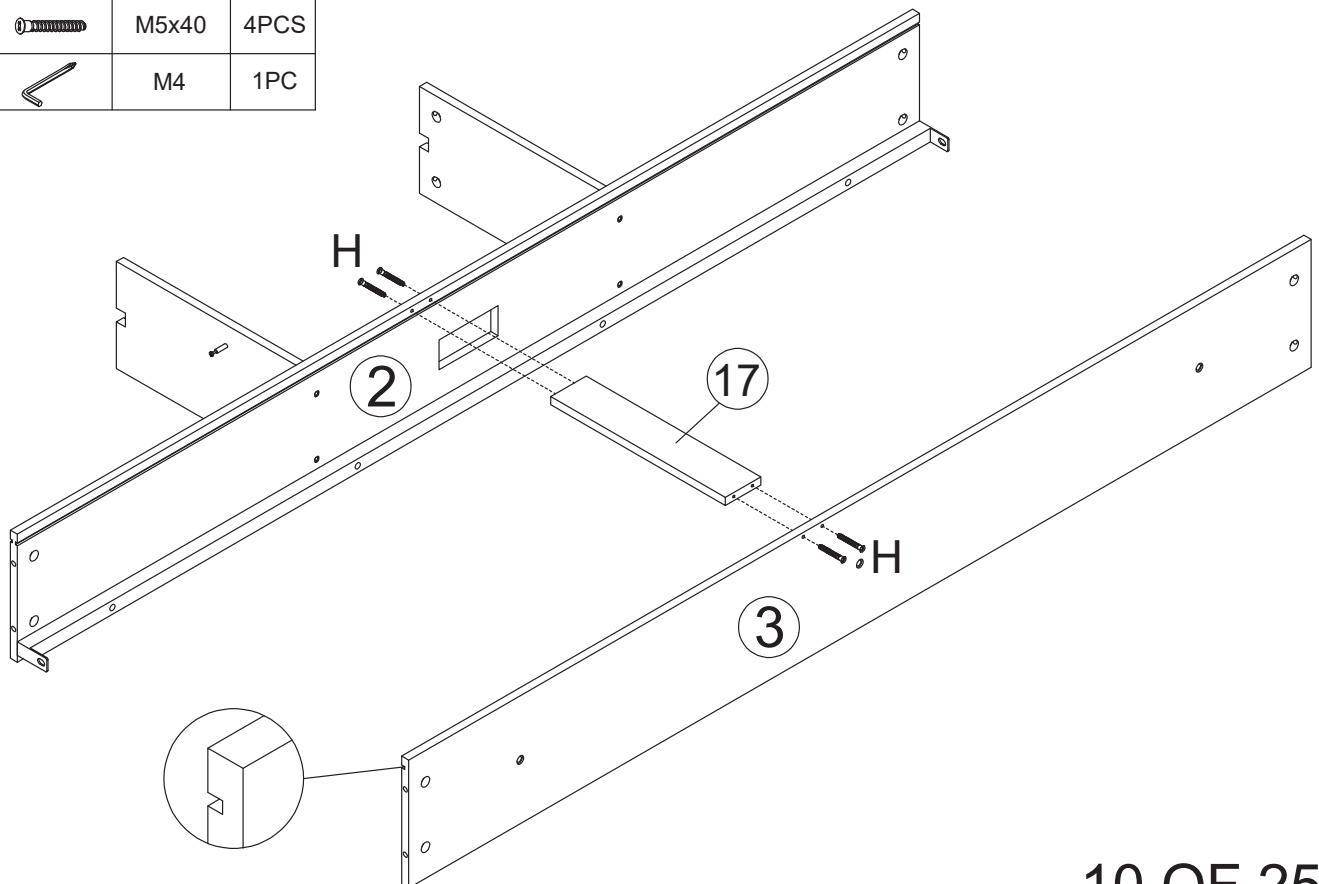

Step 14

H		M5x40	4PCS
V		M4	1PC



Step 15

J			14PCS
V		M4	1PC

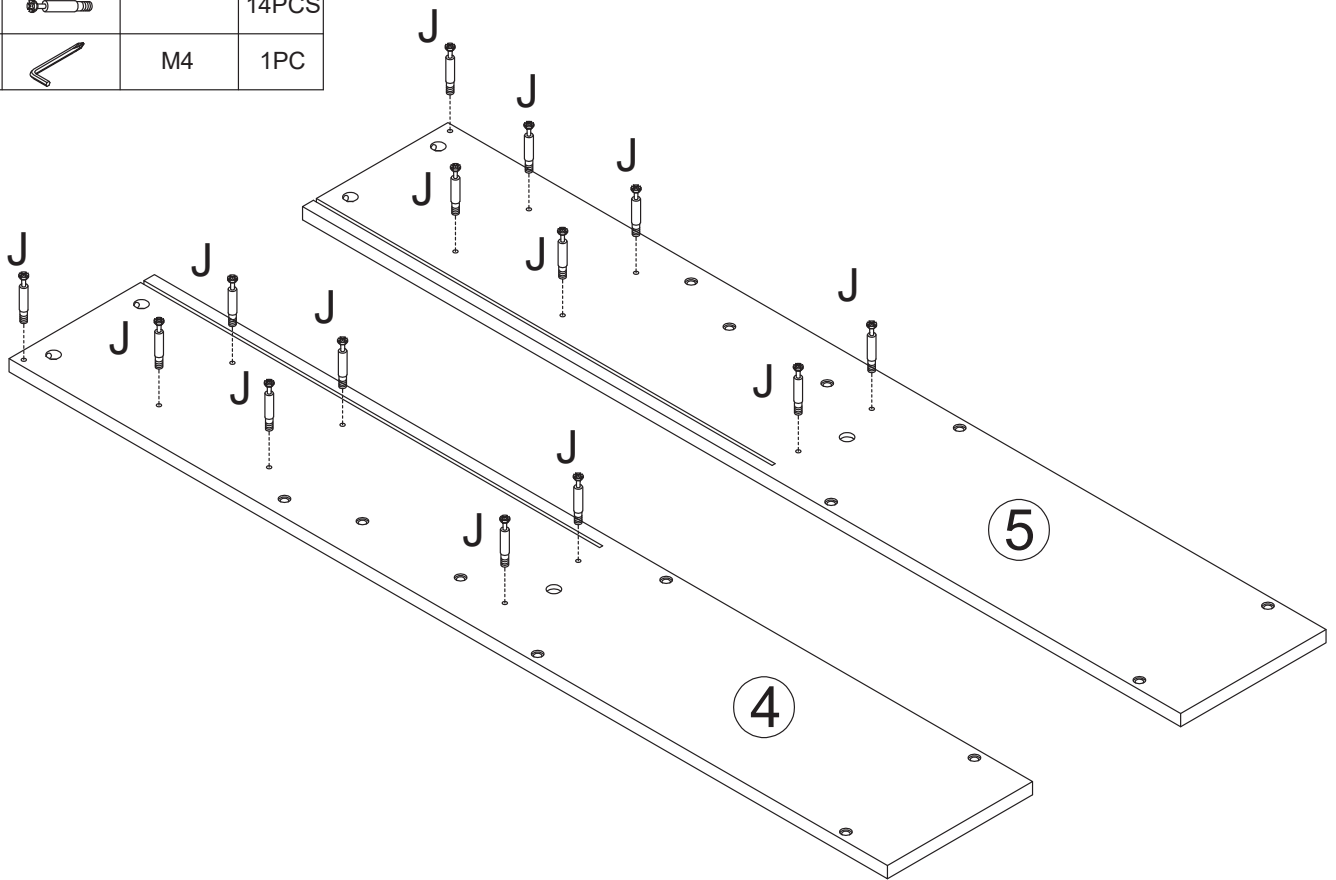

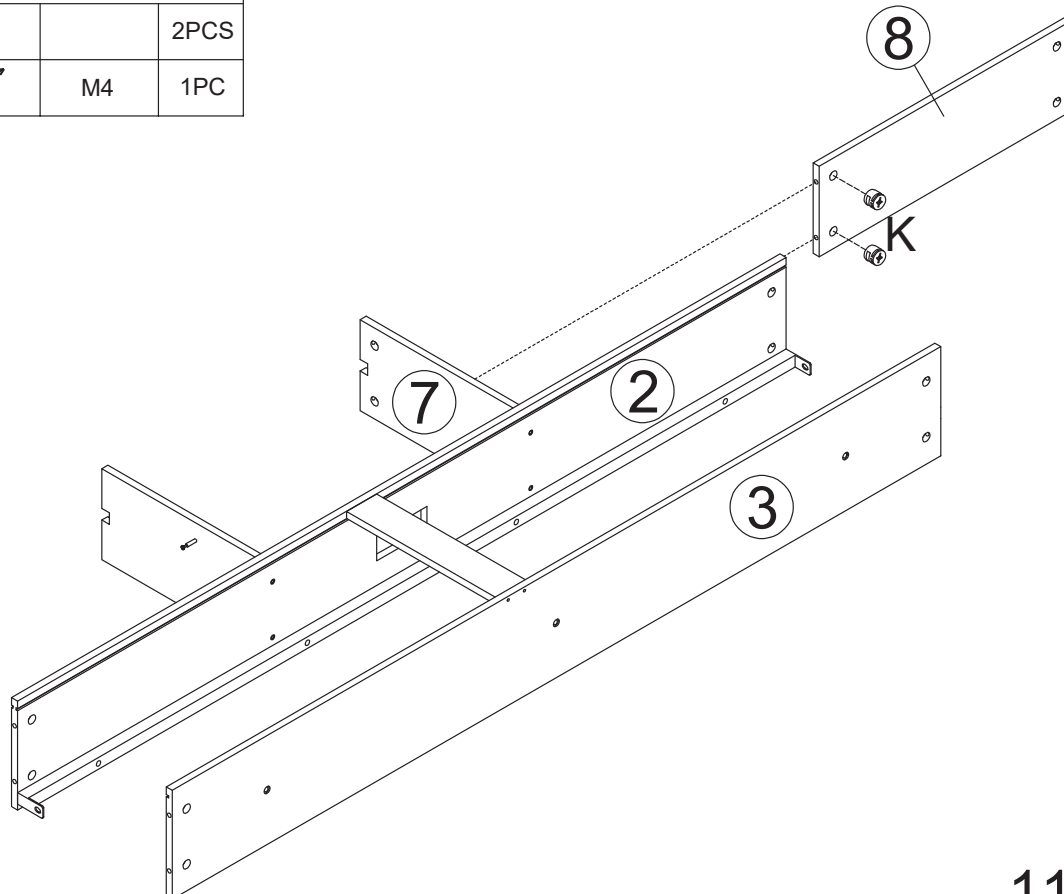

Step 16

K			2PCS
V		M4	1PC



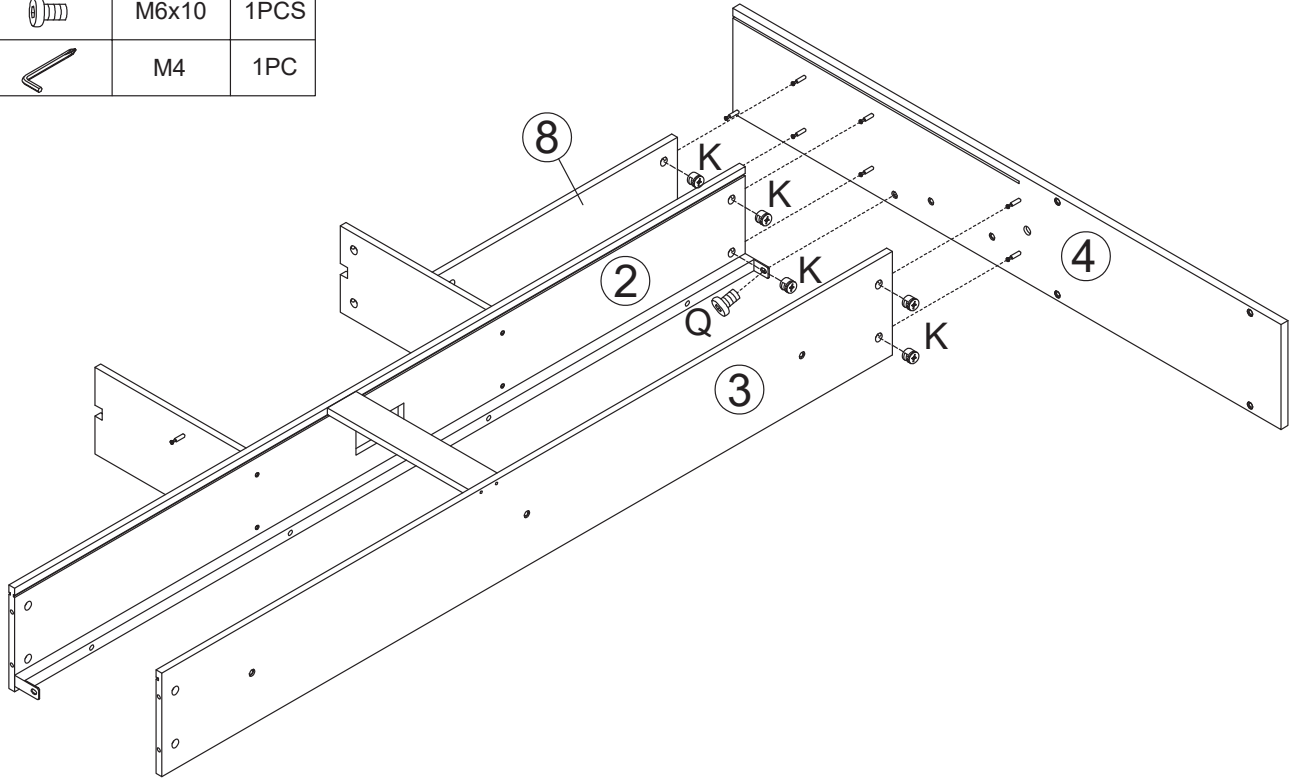

Step 17

K			6PCS
Q		M6x10	1PCS
V		M4	1PC



Step 18

G		M6x28	3PCS
S		M4	1PC

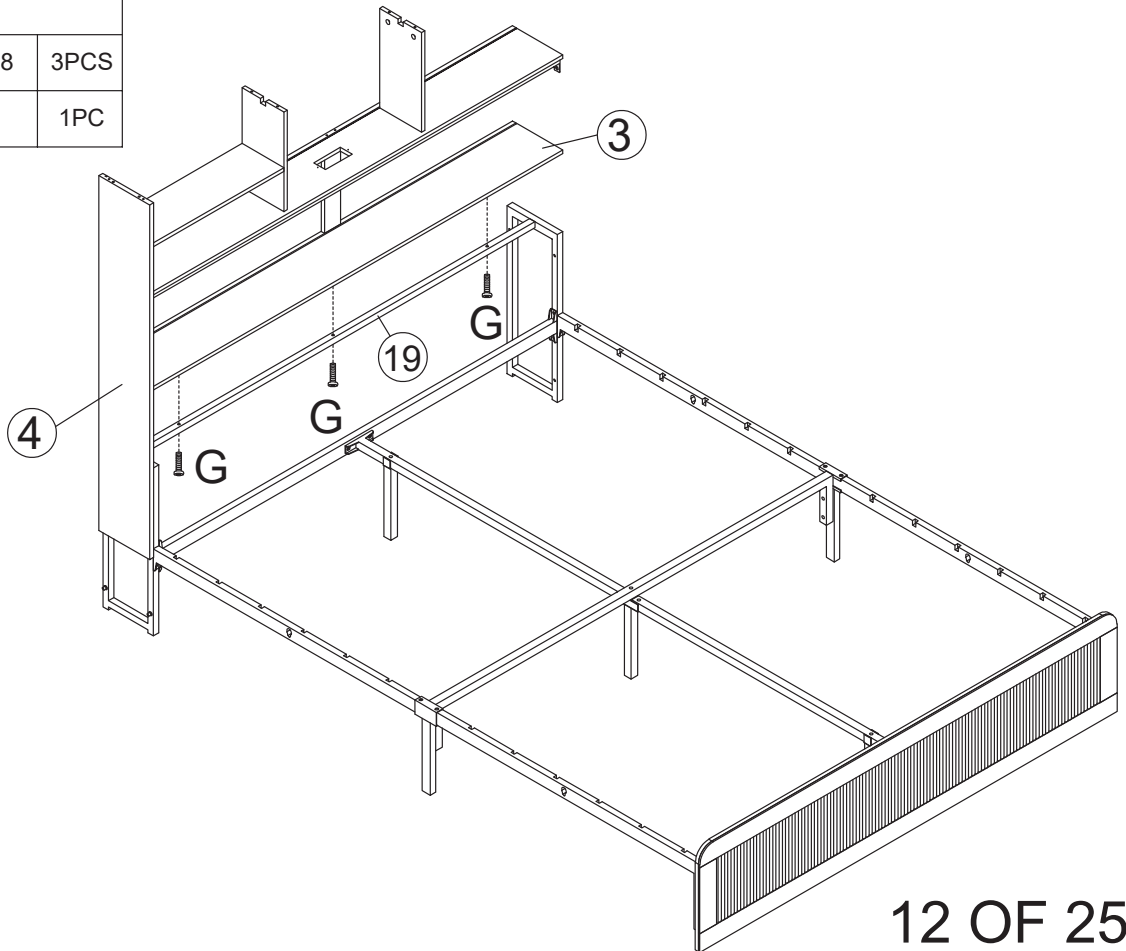

Step 19

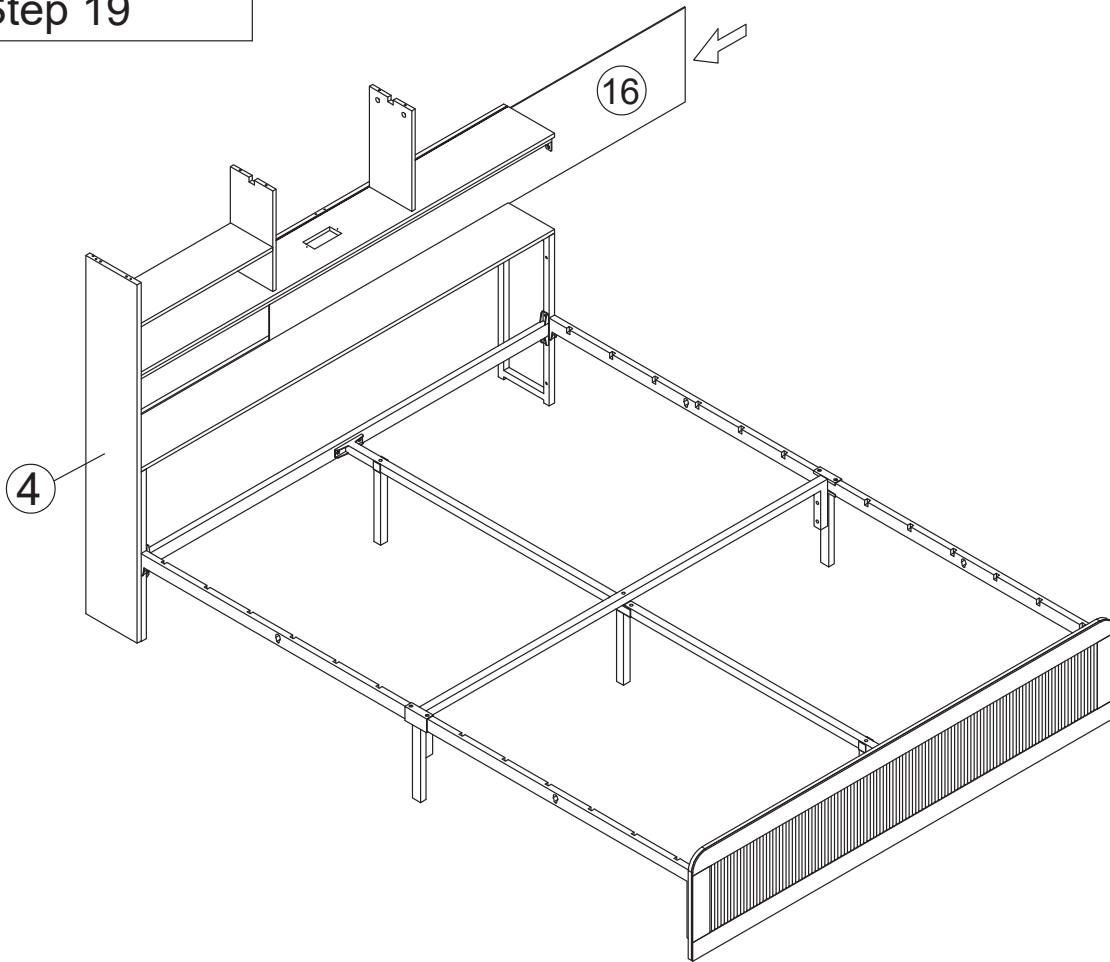

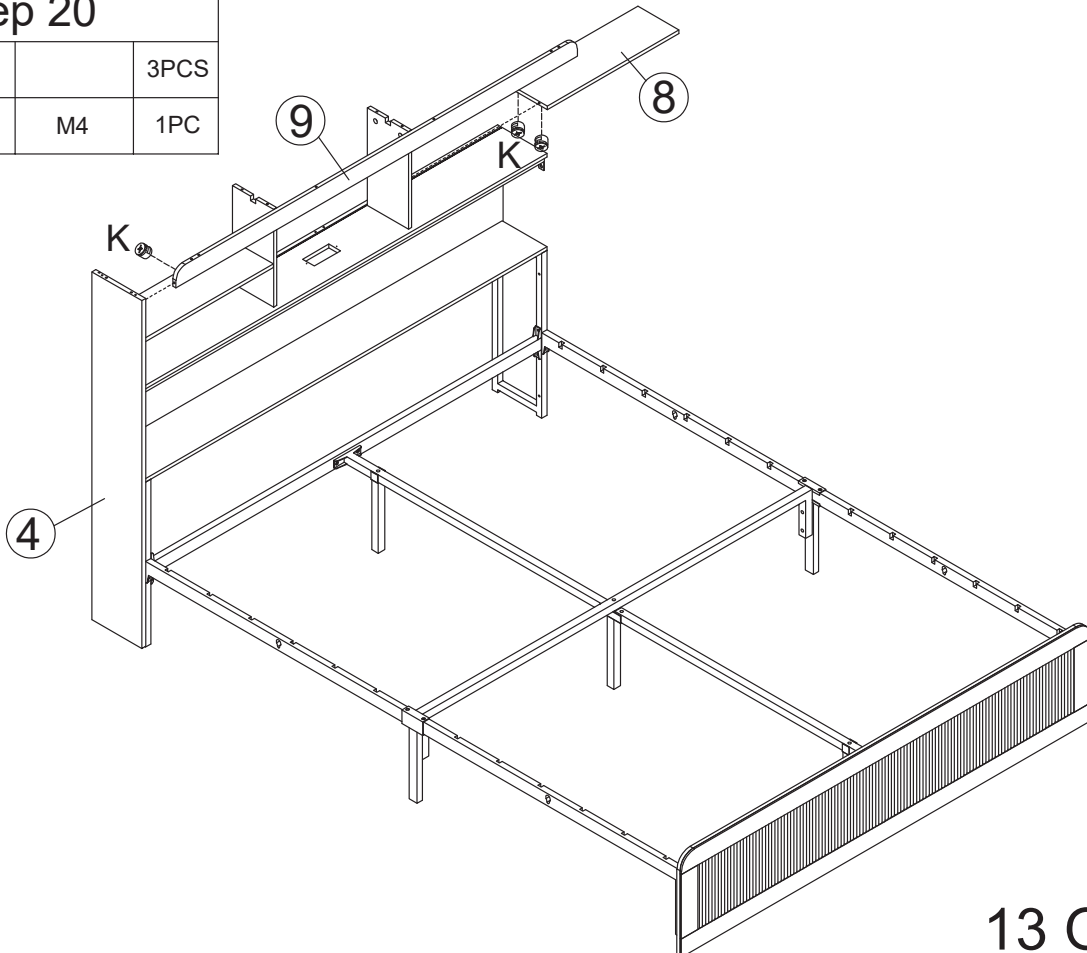

Step 20

K			3PCS
V		M4	1PC



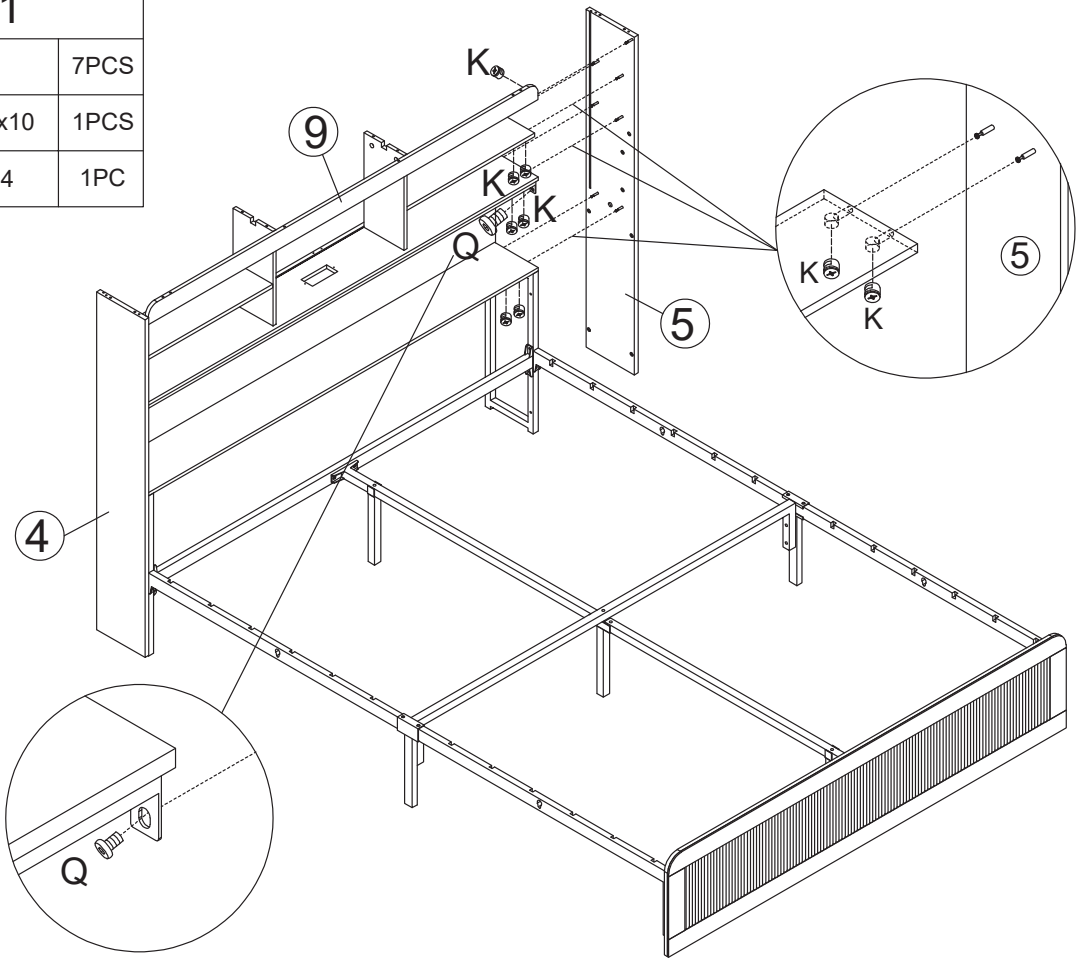

Step 21

K			7PCS
Q		M6x10	1PCS
V		M4	1PC



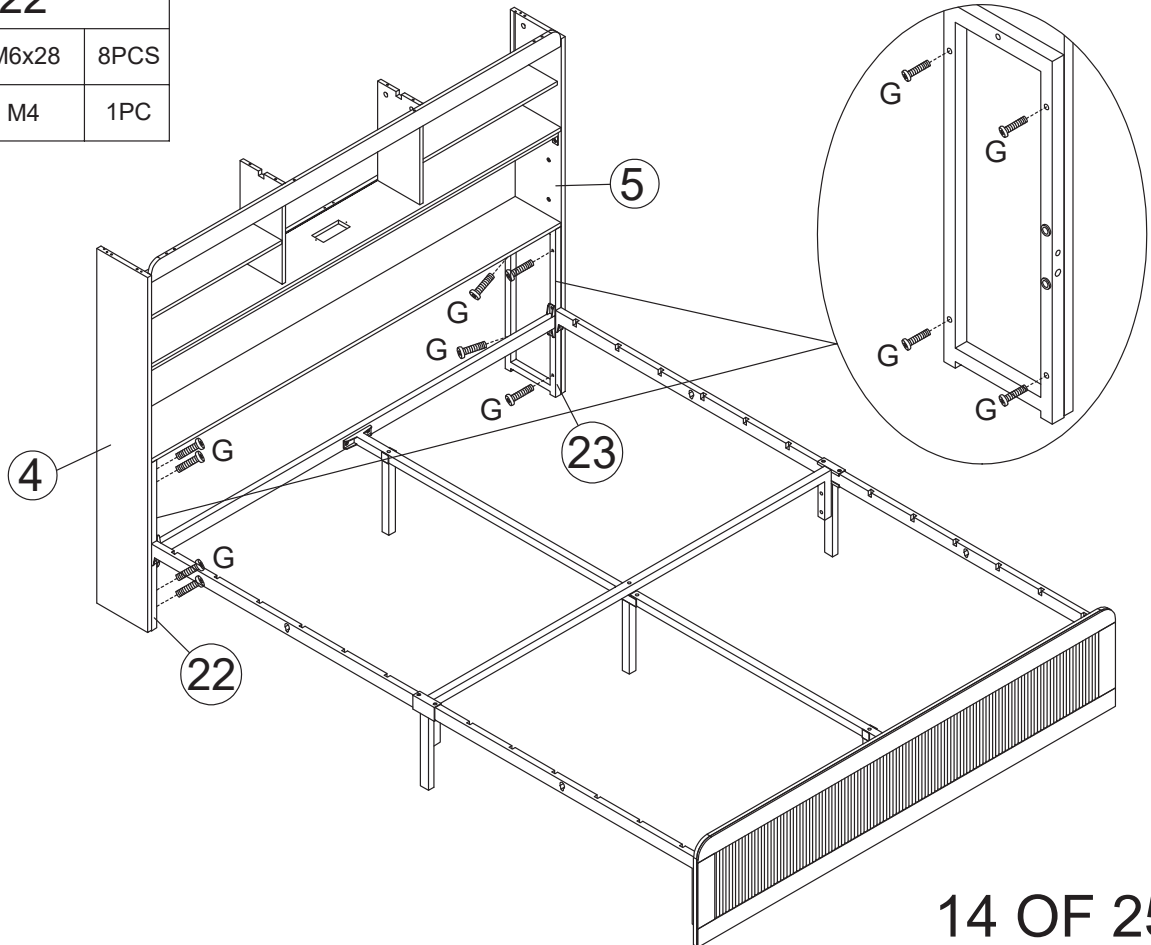

Step 22

G		M6x28	8PCS
S		M4	1PC



Step 23

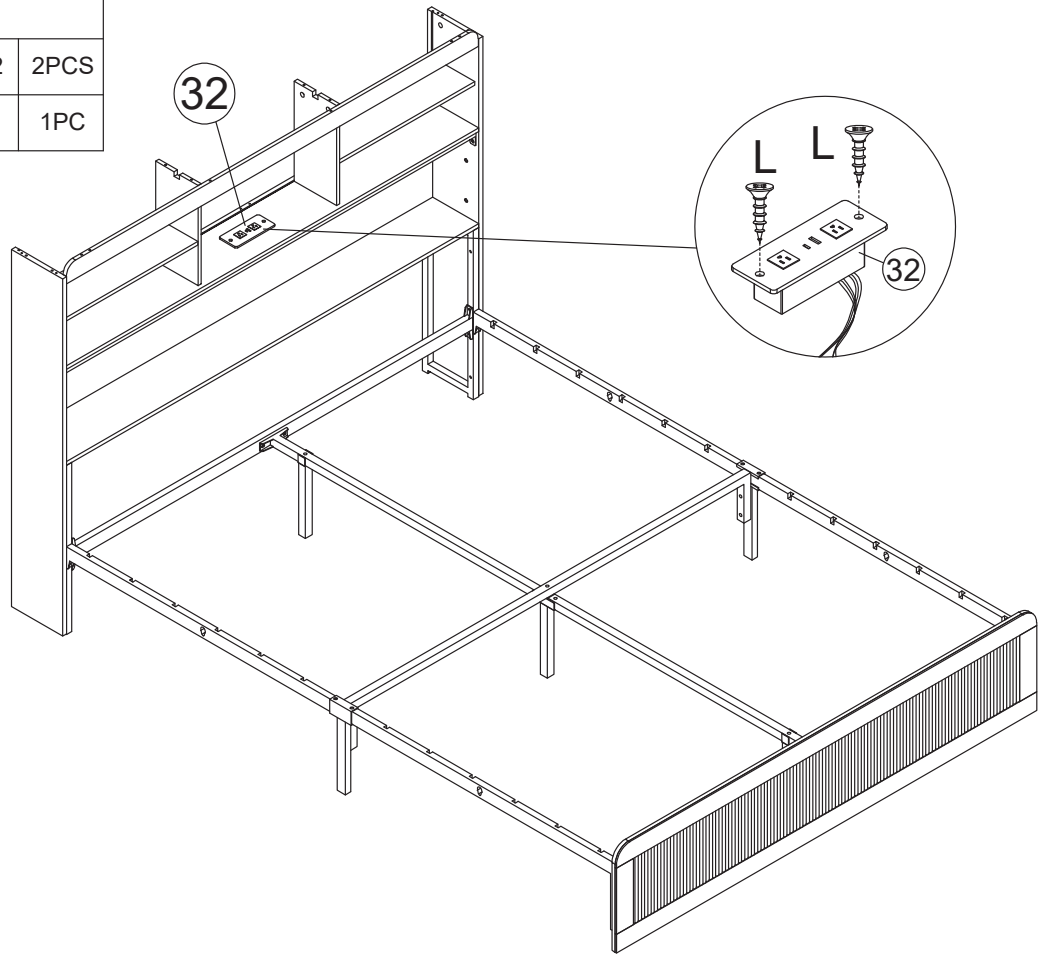

L		M3.5x12	2PCS
V		M4	1PC

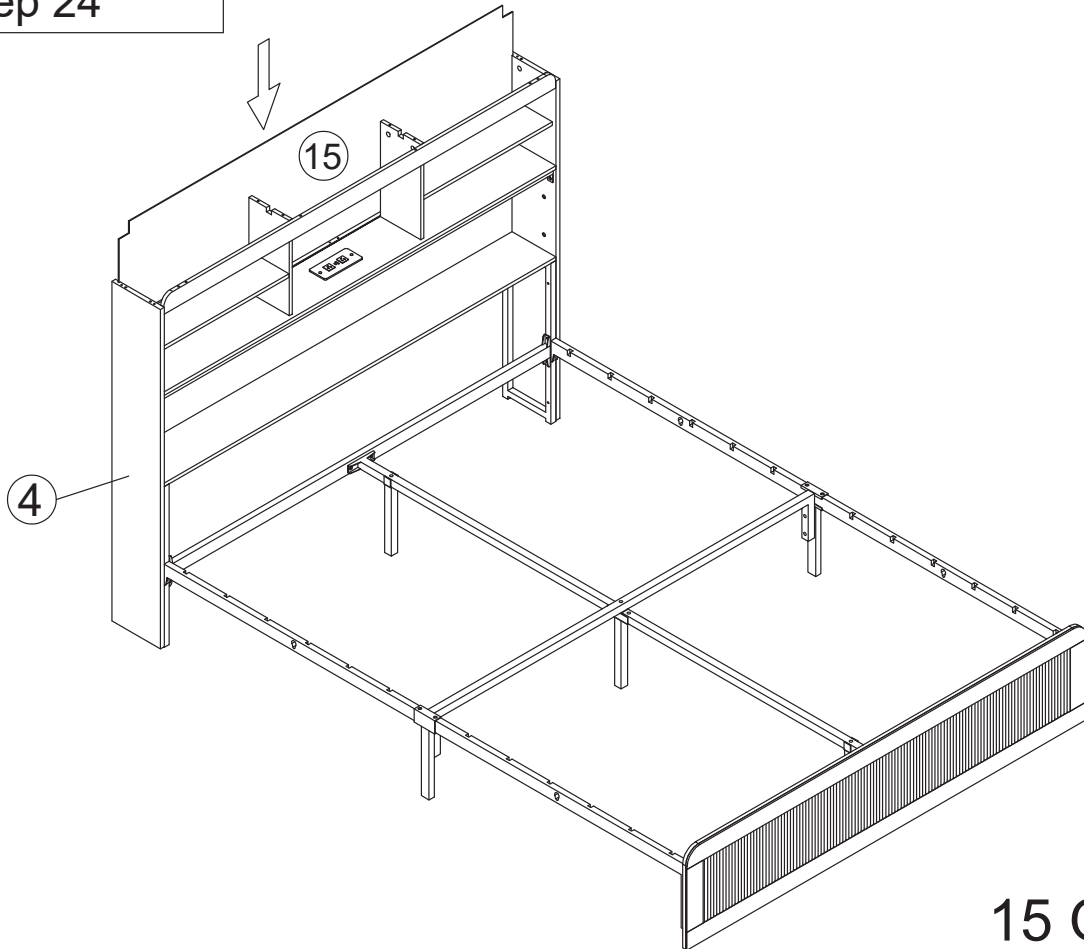

Step 24



Step 25

J			8PCS
V		M4	1PC

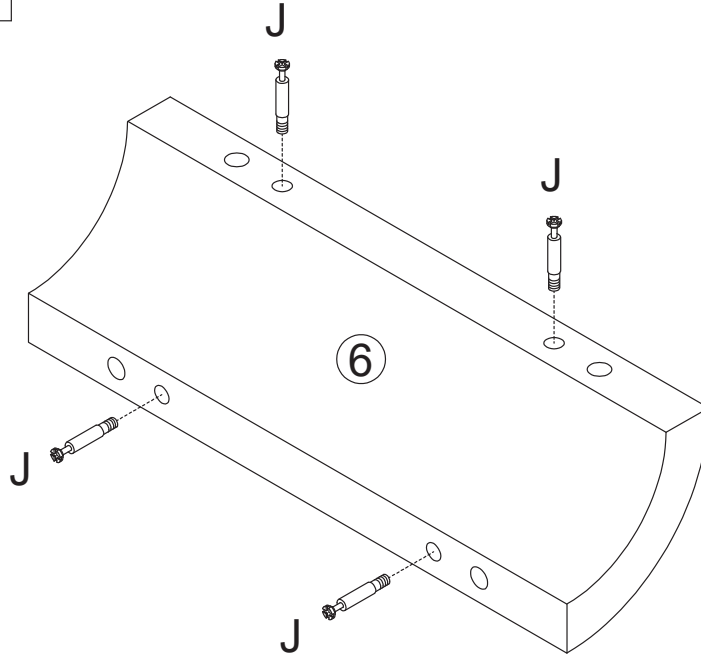

X2

Step 26

U		M6x30	4PCS
---	---	-------	------

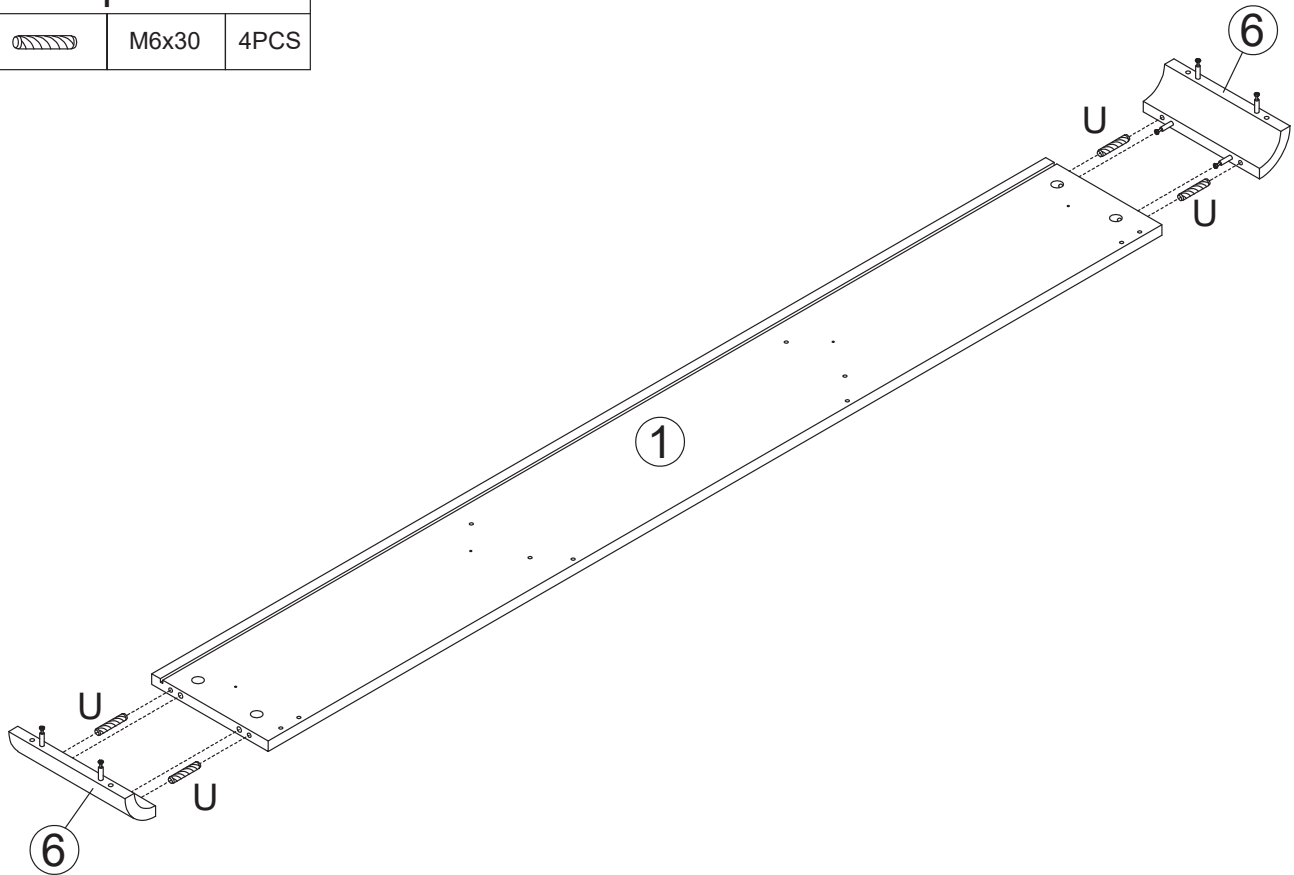

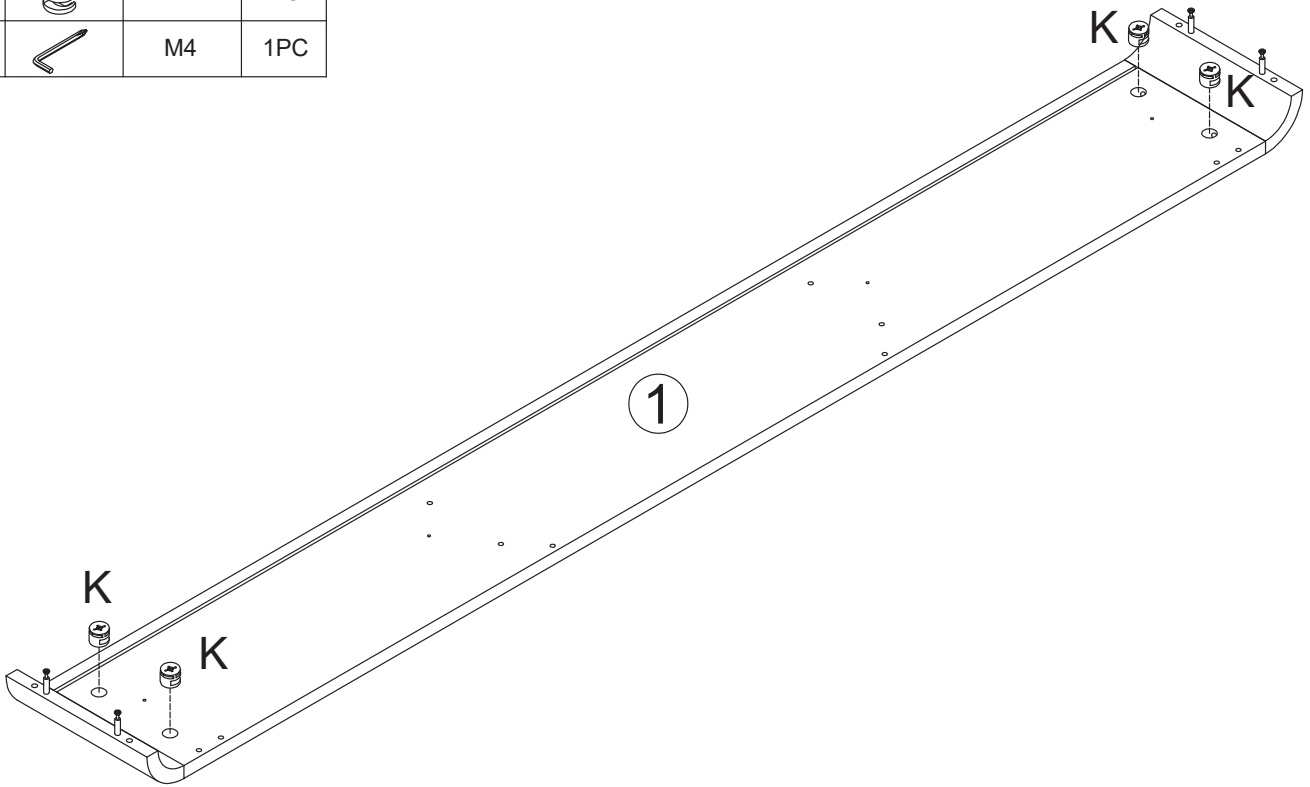

Step 27

K			4PCS
V		M4	1PC



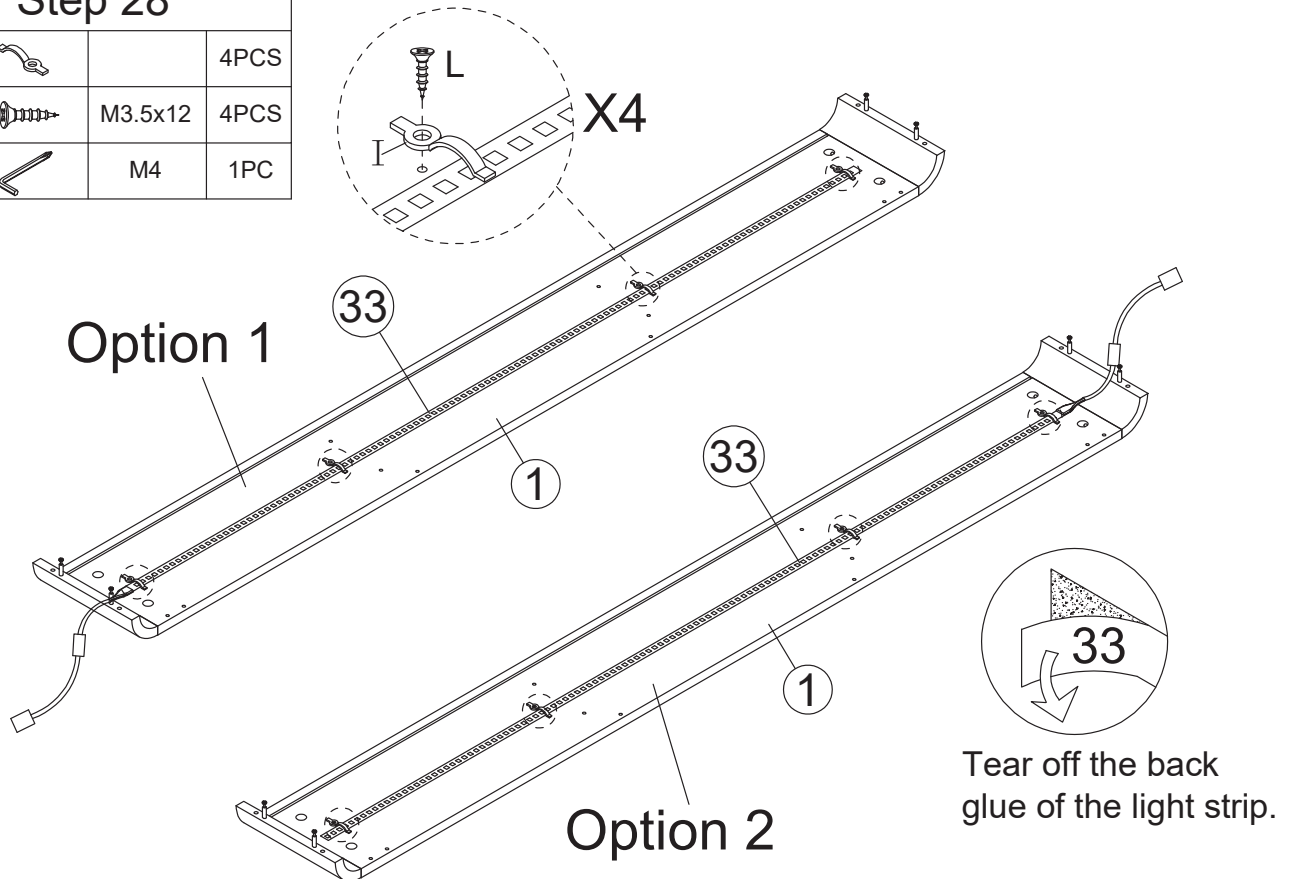

Step 28

I			4PCS
L		M3.5x12	4PCS
V		M4	1PC



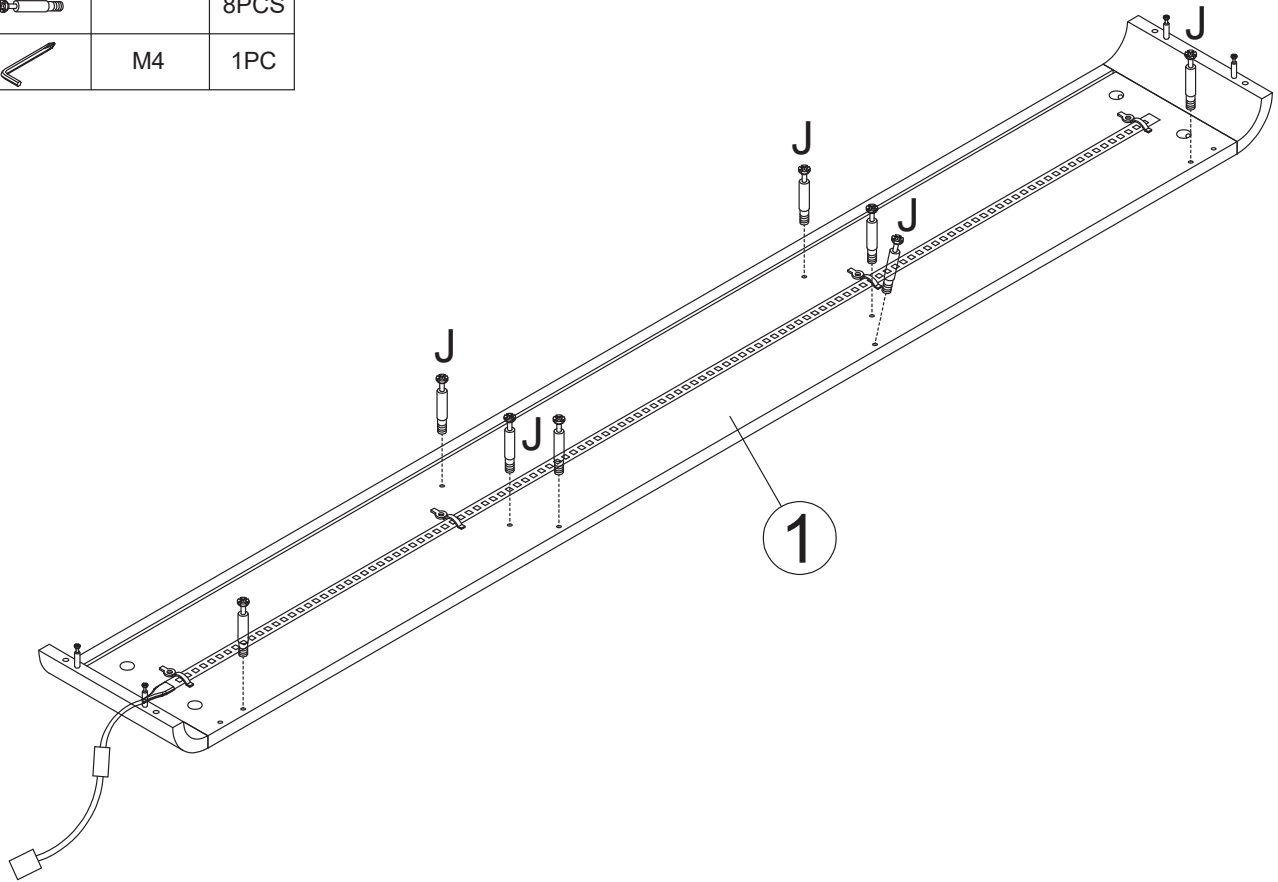

Step 29

J			8PCS
V		M4	1PC



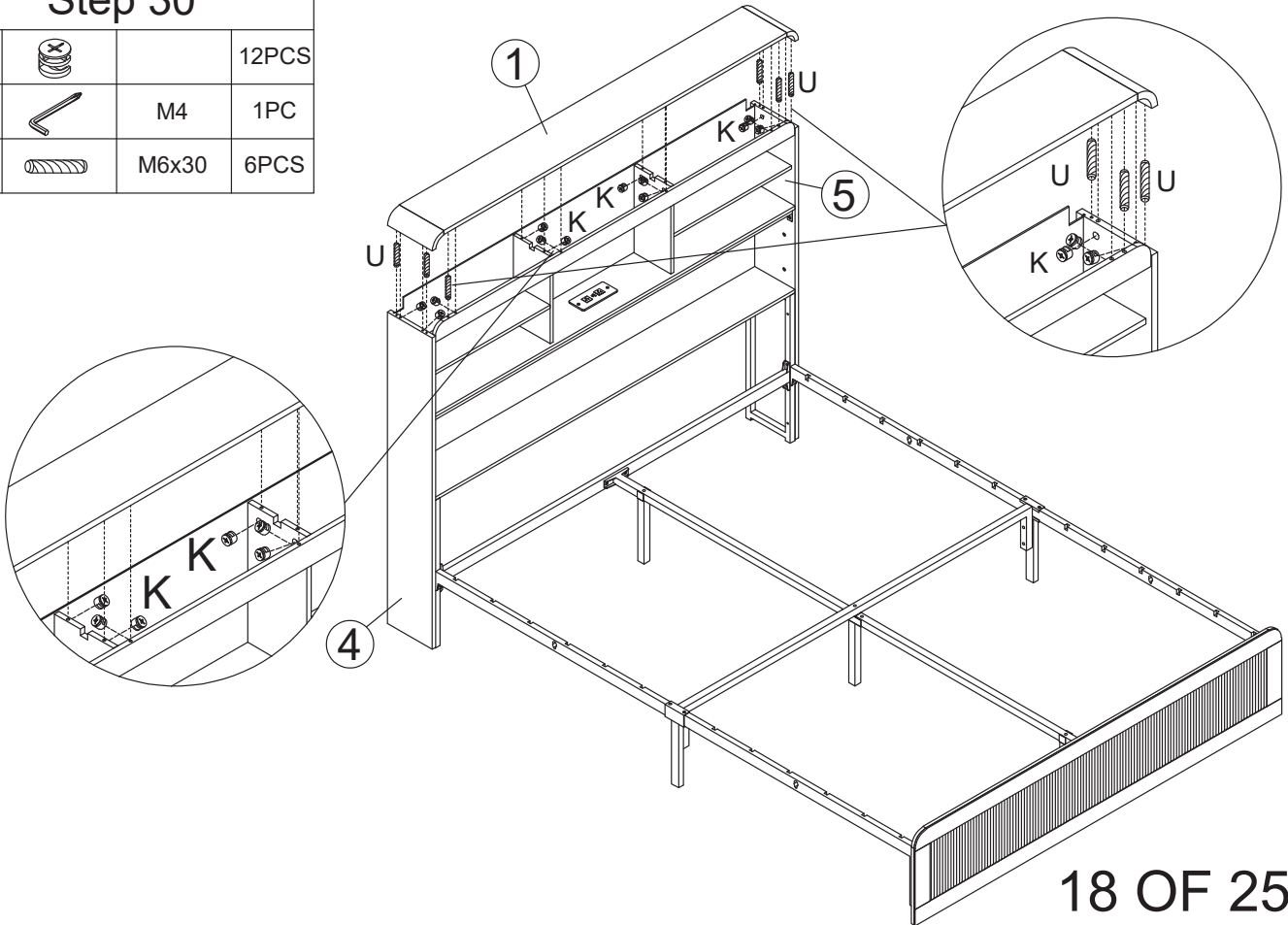

Step 30

K			12PCS
V		M4	1PC
U		M6x30	6PCS



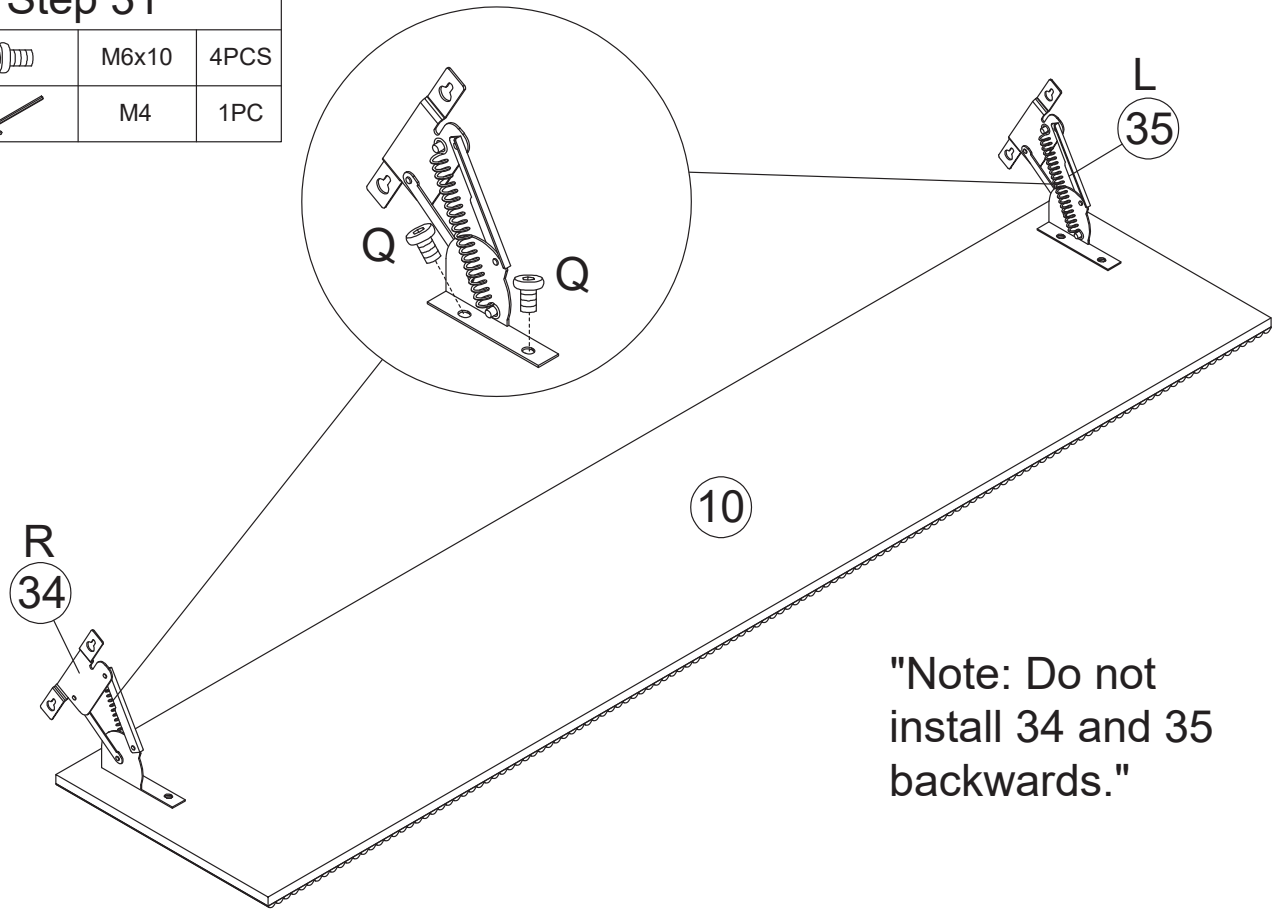

Step 31

Q		M6x10	4PCS
S		M4	1PC



"Note: Do not install 34 and 35 backwards."

Step 32

Q		M6x10	4PCS
S		M4	1PC

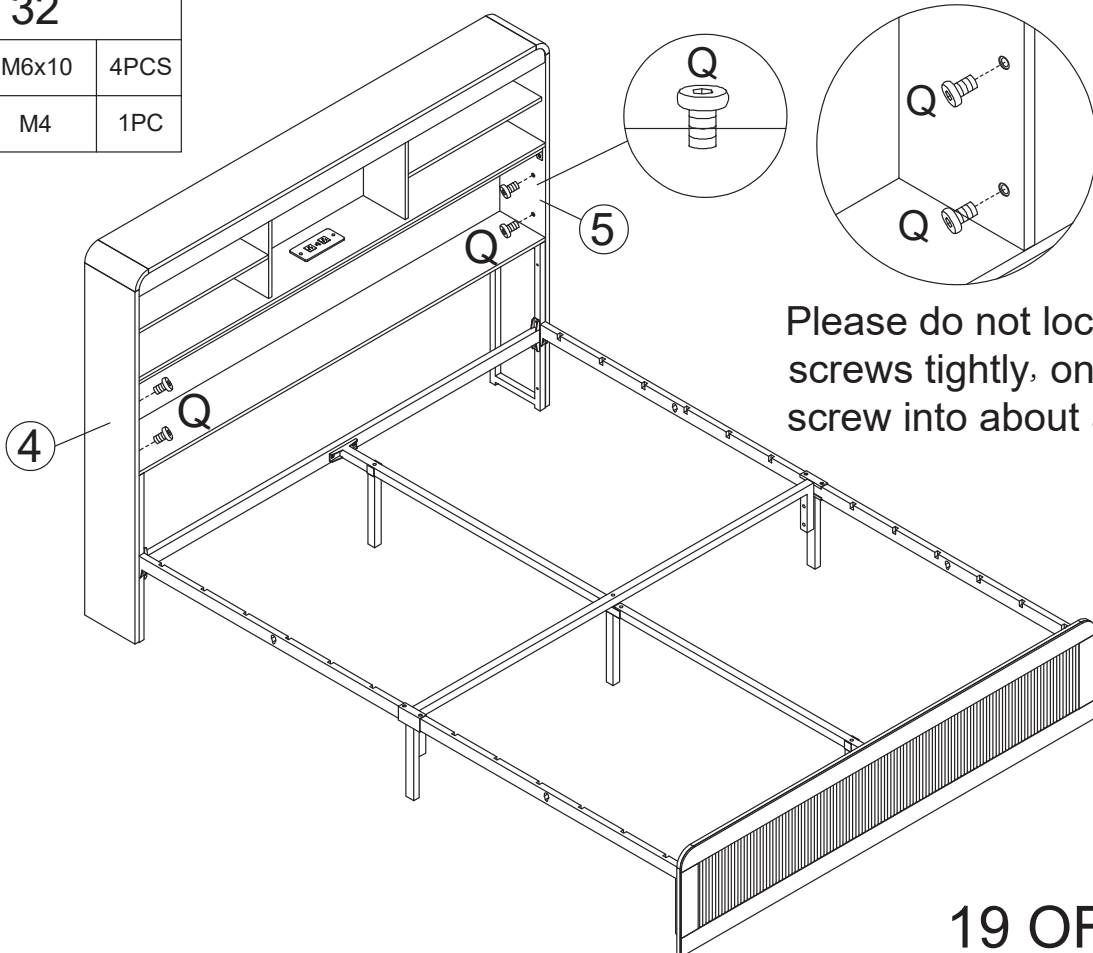

Please do not lock the screws tightly, only screw into about 50%.

Step 33

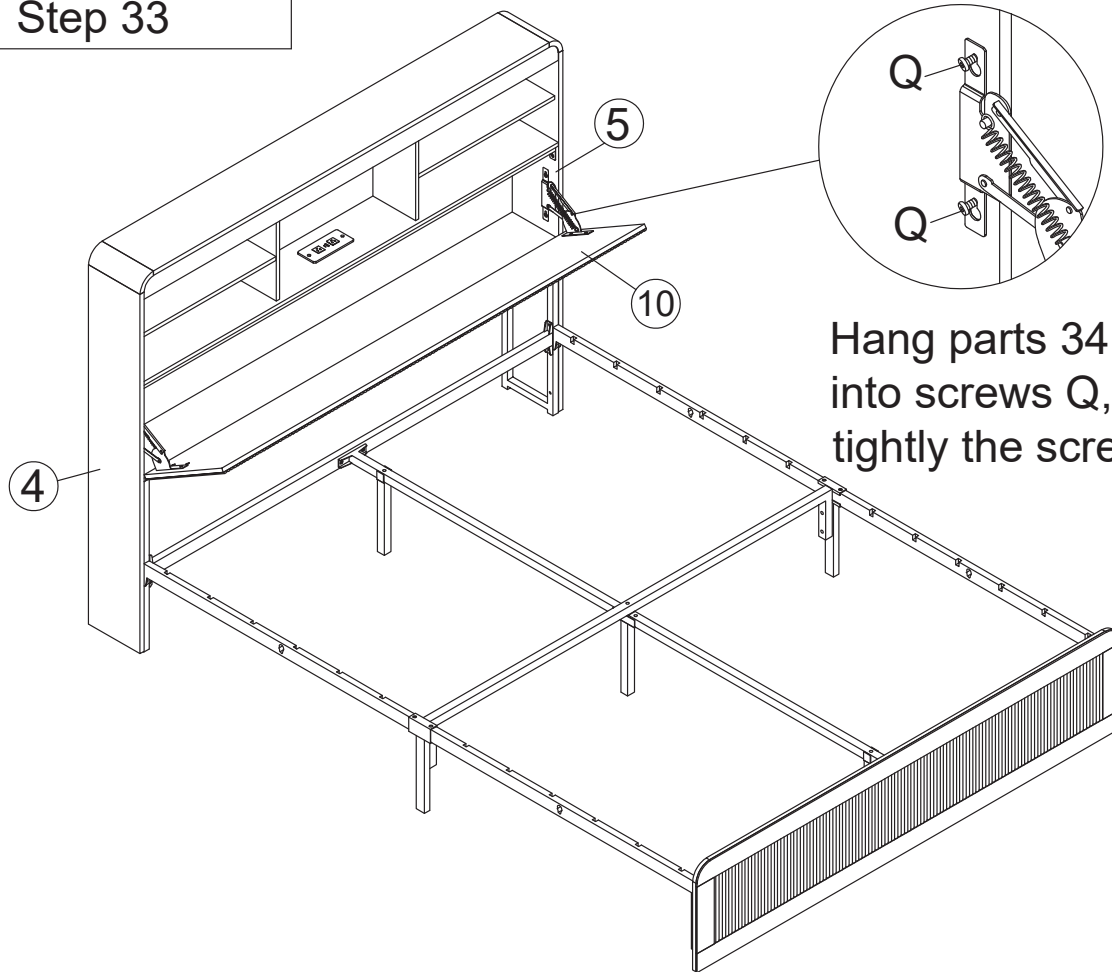

Hang parts 34 and 35 into screws Q, and then tightly the screws Q.

Step 34

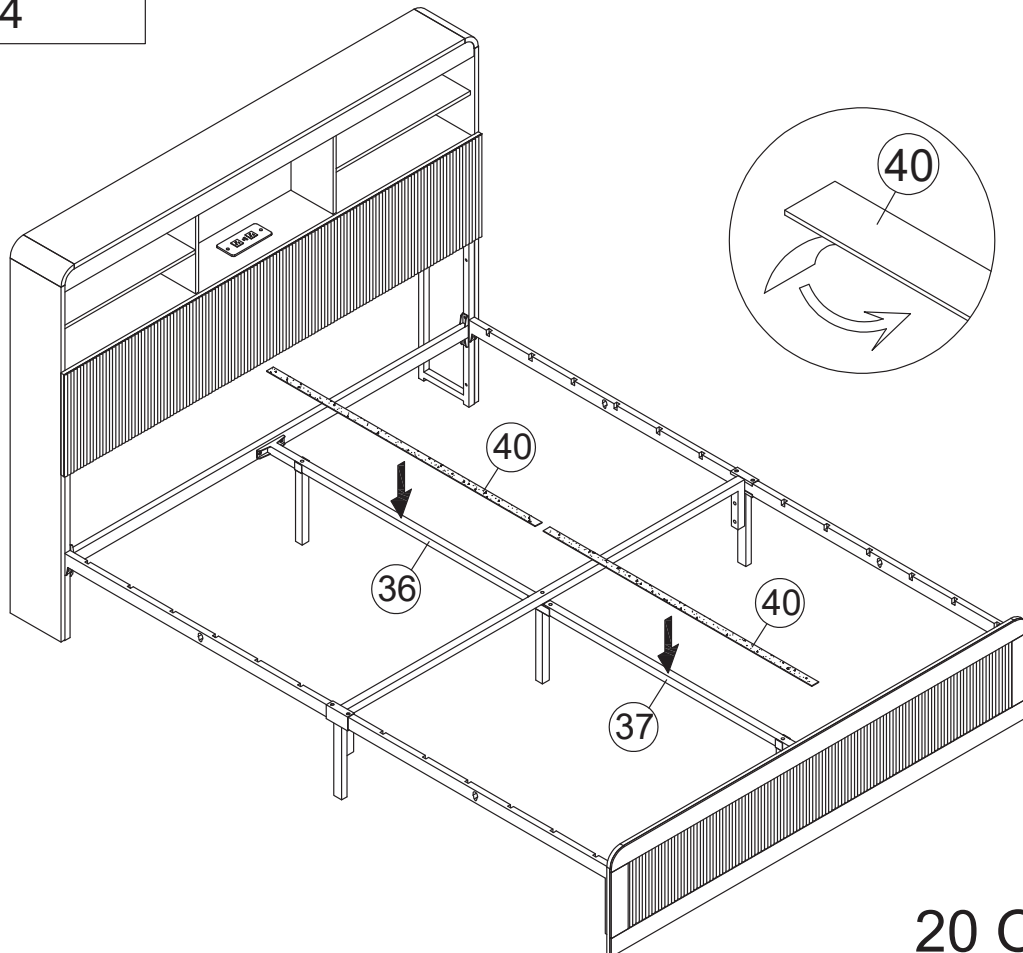

Step 35

M



24PCS

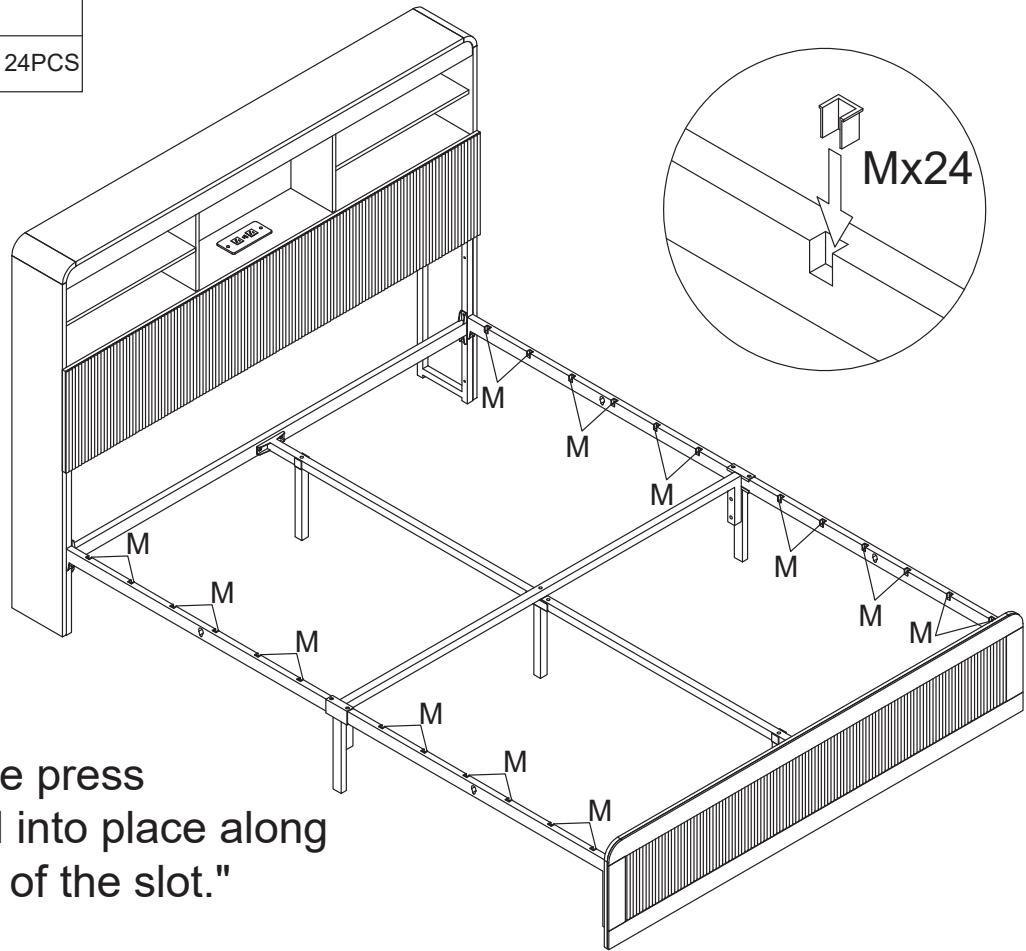

"Note: Please press accessory M into place along the direction of the slot."

Step 36

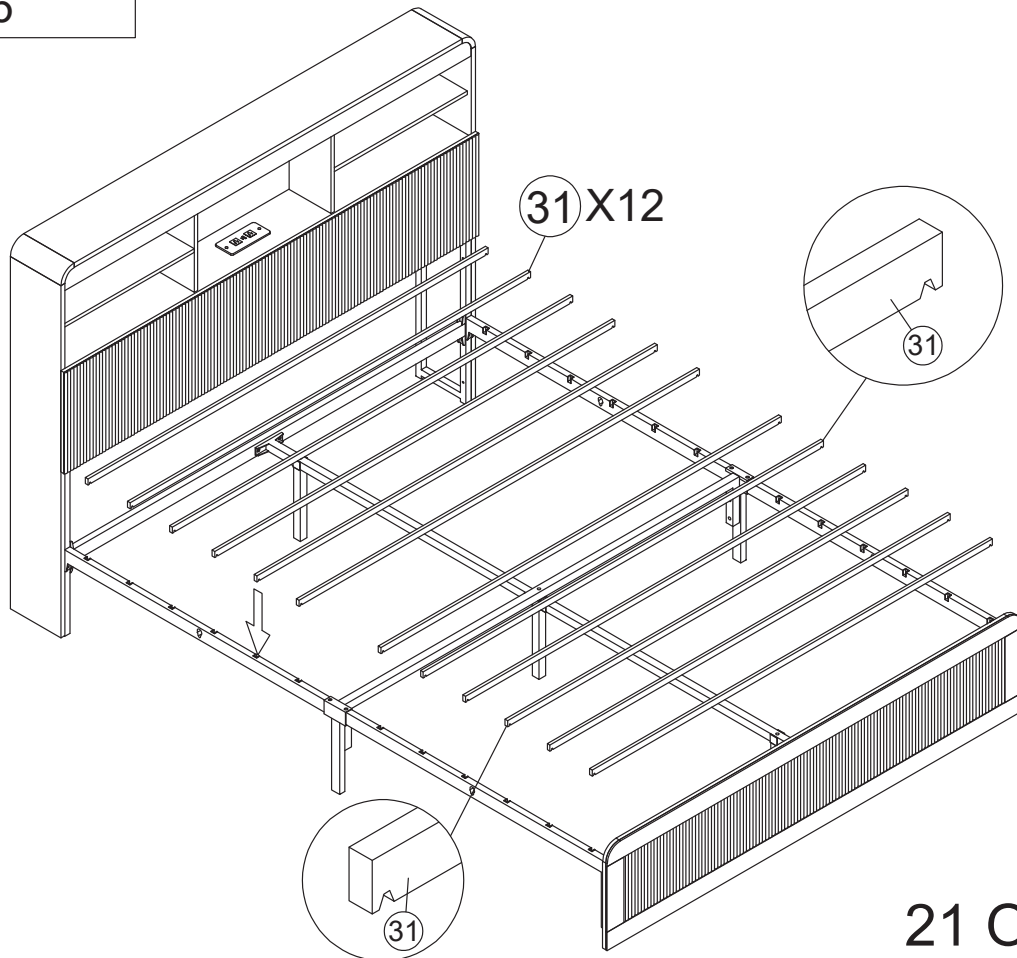

Step 37

O



8PCS

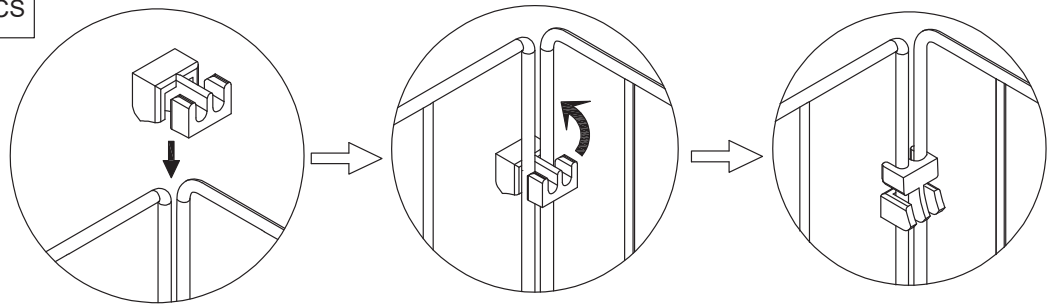

X4

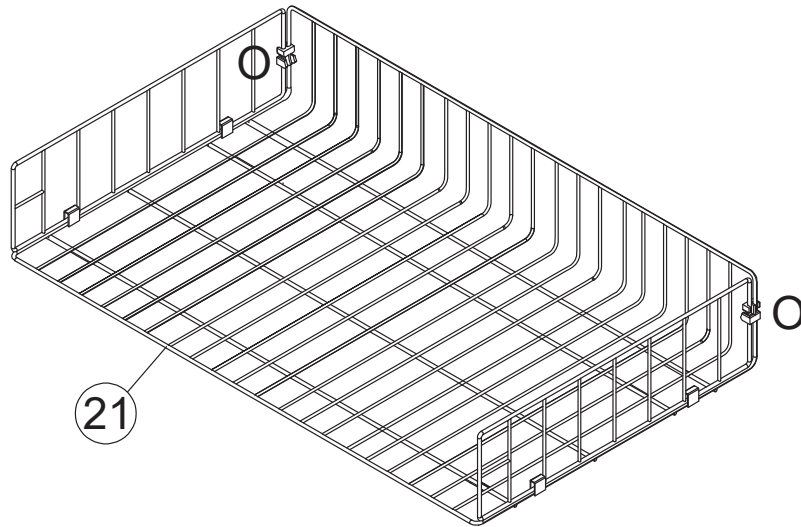

Step 38

N





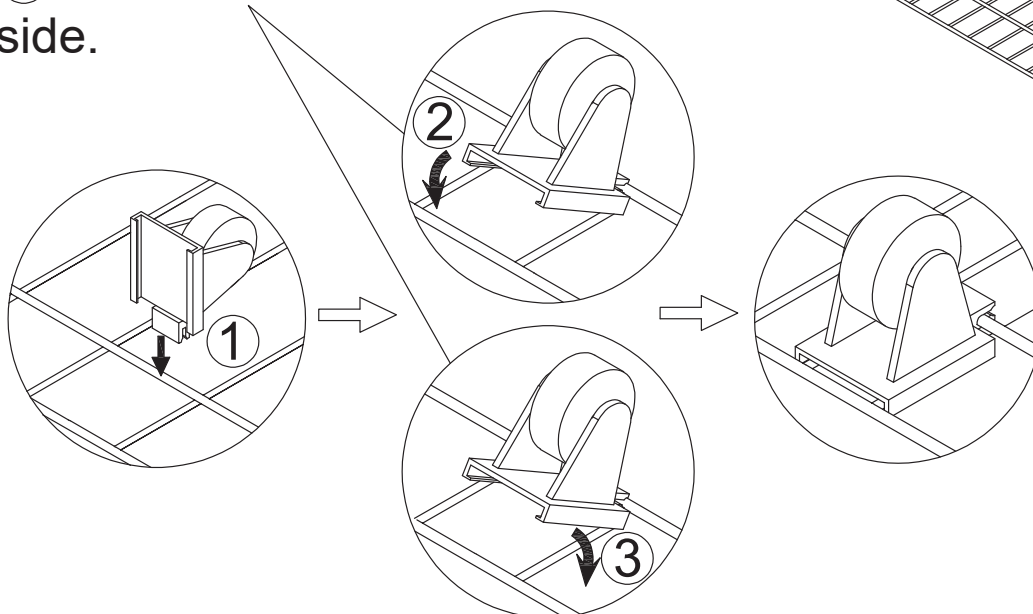
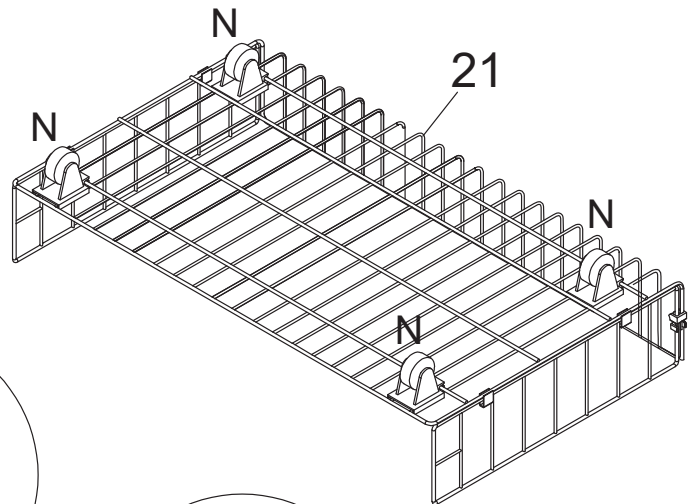

16PCS

Attention: ② make sure plastic slot stuck into one side of the tube firstly, and ③ then to stuck into another side.



X4

Step 39

Q		M6x10	12PCS
P			12PCS
R			4PCS
S		M4	1PC

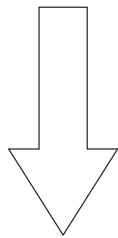
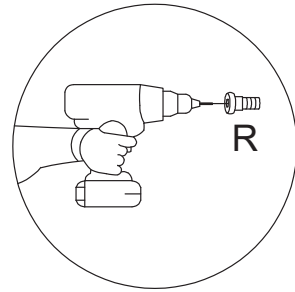
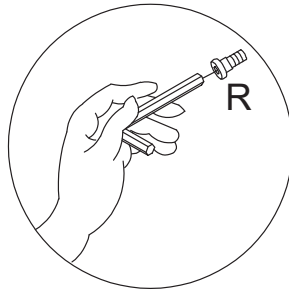
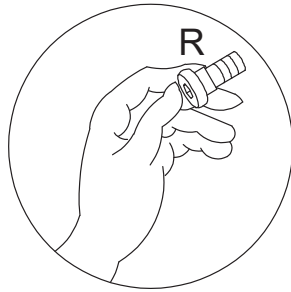
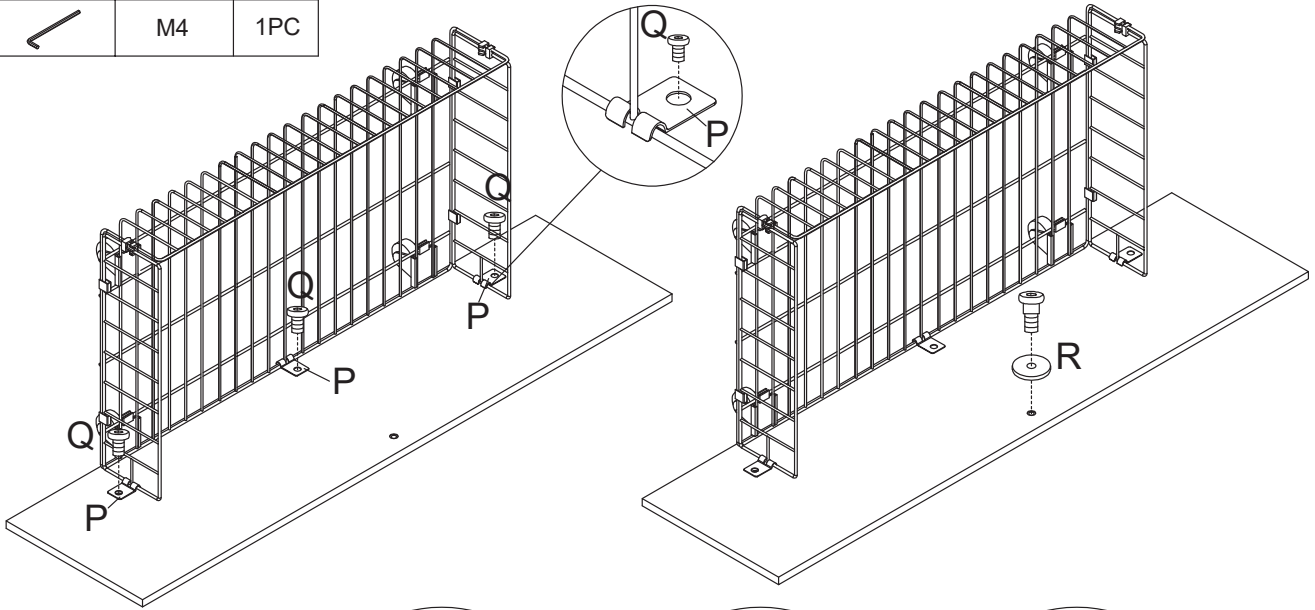

Note: Please don't fully tighten R screws to the board.

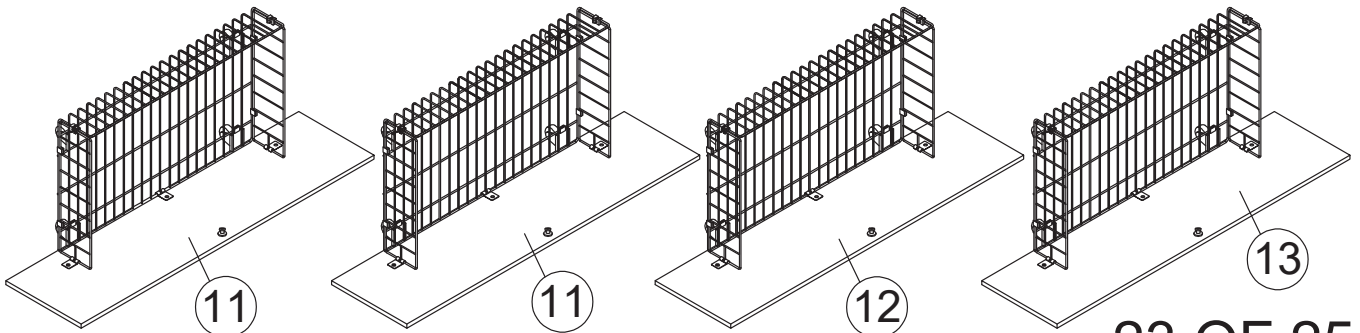

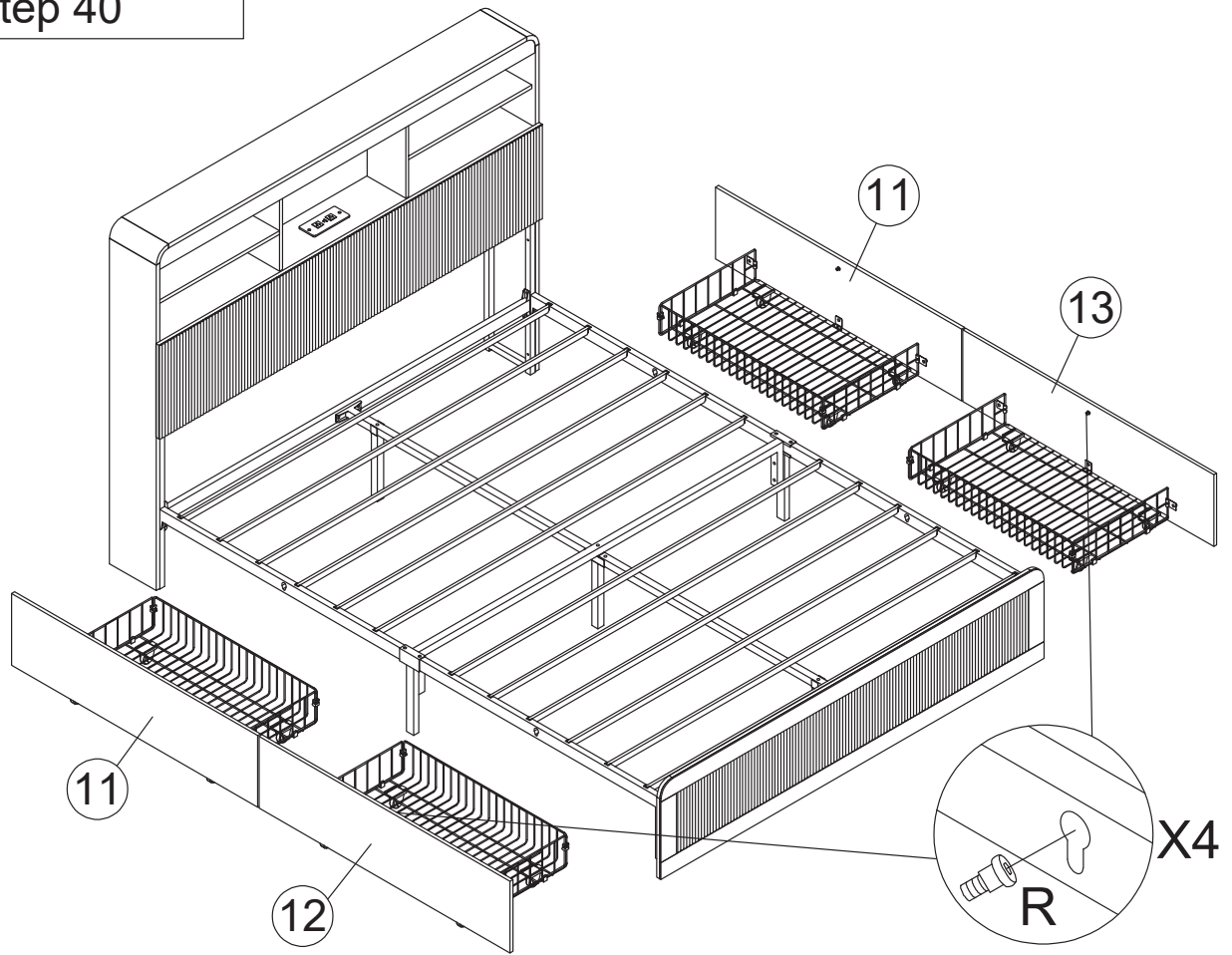

Step 40

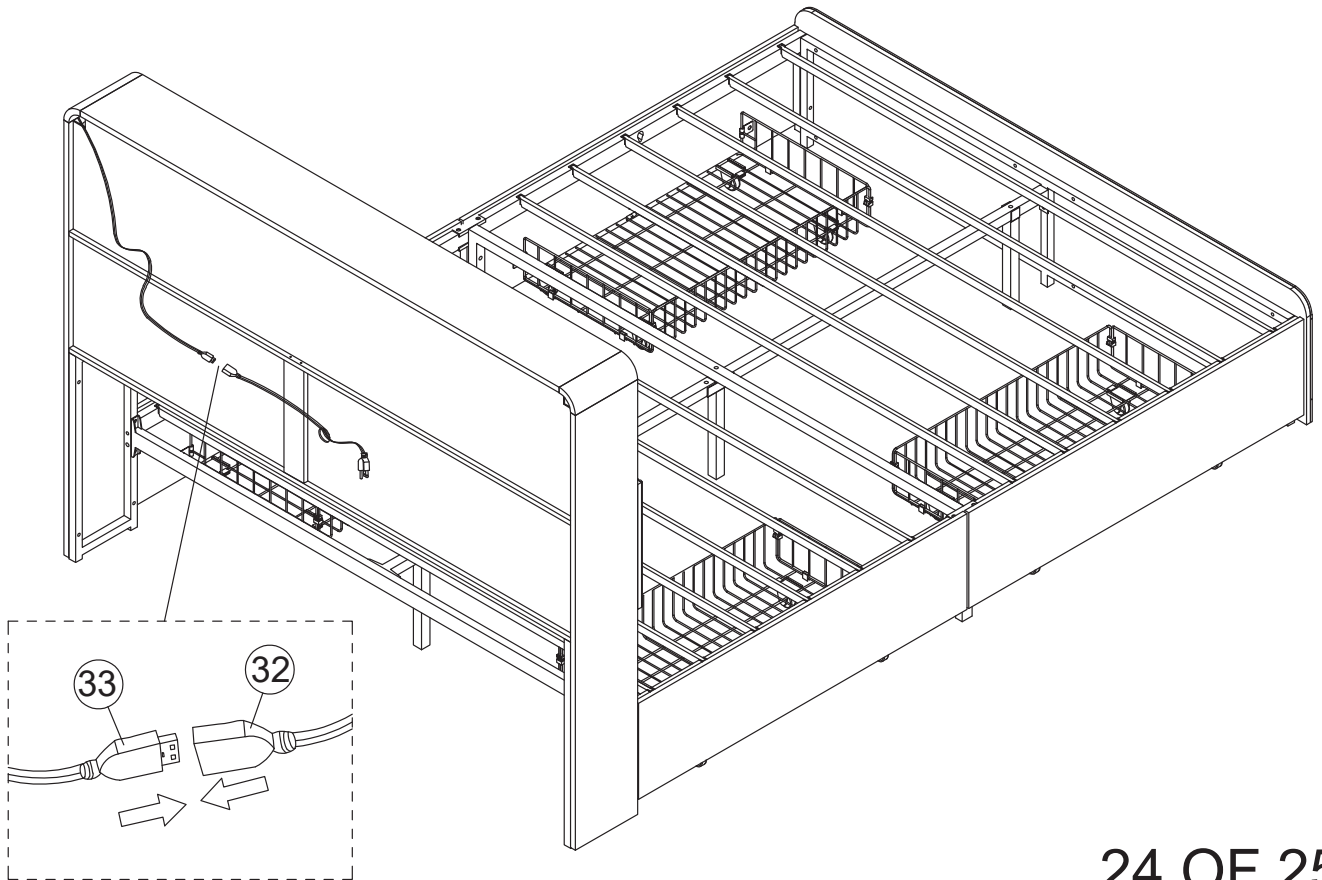

Step 41



Step 42

L		M3.5X12	12PCS
W			12PCS
V		M4	1PC

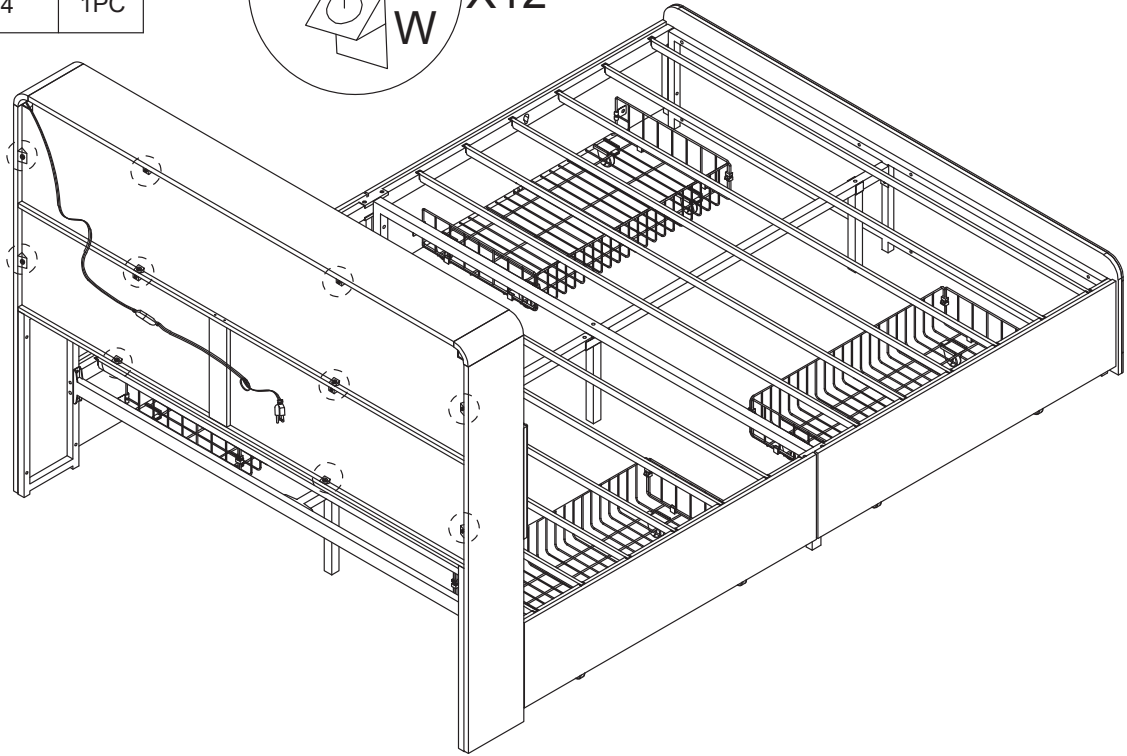
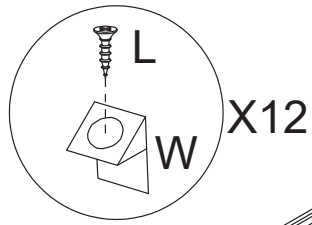

Step 43

