

THKFBV131DW0A2

THKFBV131GY0A2

THKFBV131WH0A2

INSTALLATION INSTRUCTIONS

*The vessel and faucet set is not included

DIMENSIONS



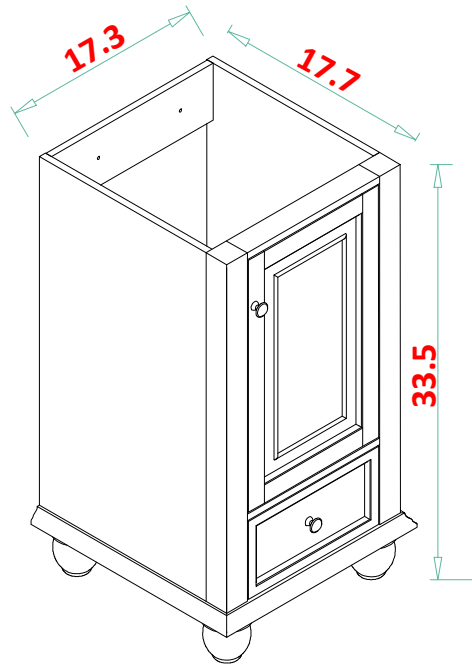



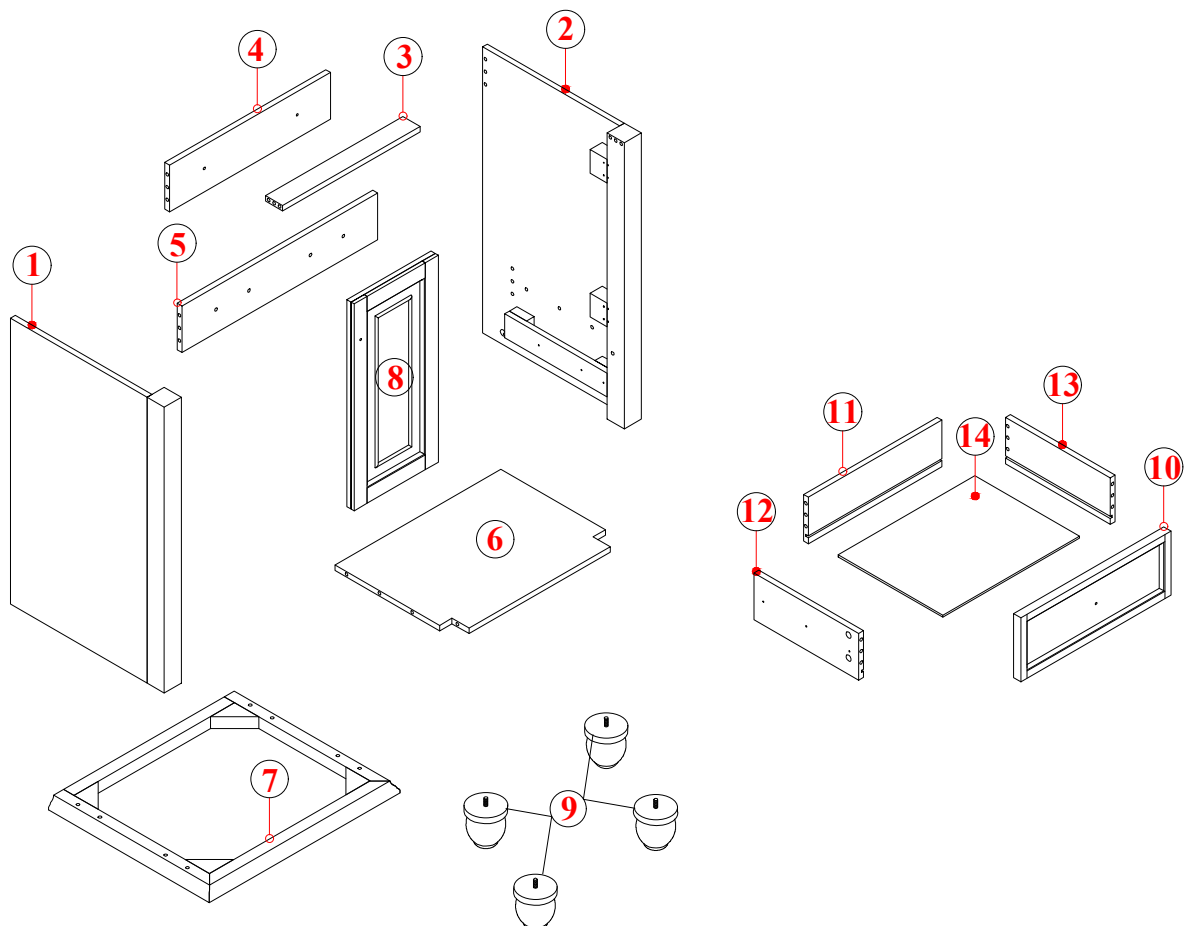



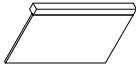

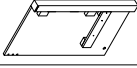



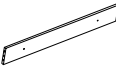

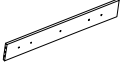
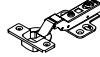



Unit: inch



ASSEMBLY DIAGRAM



PARTS LIST

PARTS LIST			HARDWARE LIST		
No.	Description	QTY	No.	Description	QTY
1		1	A	 Three-in-one Connector	28
2		1	B	 Handle	2
3		1	C	 Handle Screws M4x20	1
4		1	D	 Handle Screws M4x28	1
5		1	E	 Hinges	2
6		1	F	 Screws M3.5x15	12
7		1	G	 Slider	2
8		1	H	 Screws M3x12	14
9		4	I	 Wood Plug	24
10		1	J	 Screws For Fix On The Wall	2
11		1			
12		1			
13		1			
14		1			

CAUTION: Please confirm the parts list before installtion

YOU MAY NEED (NOT SUPPLIED)

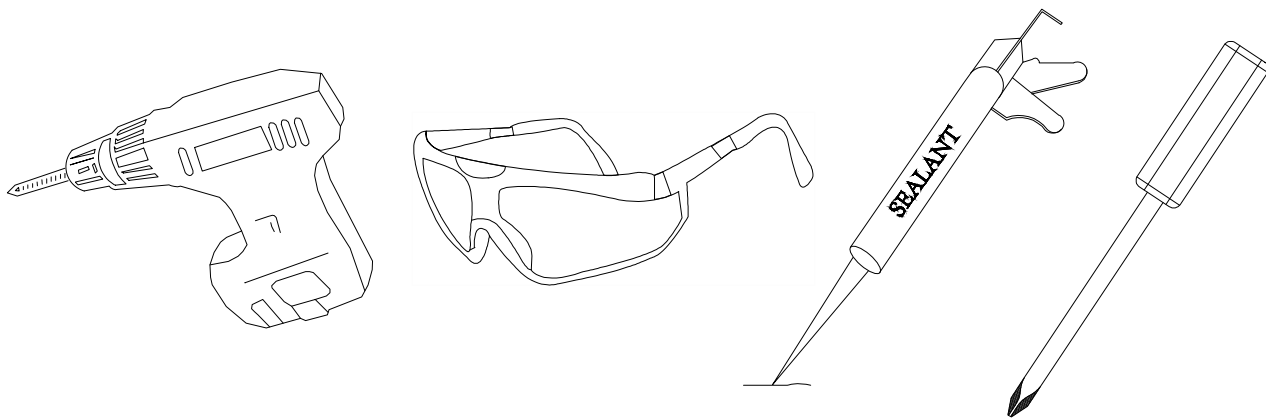

INSTALLATIONS

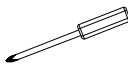

STEP 1

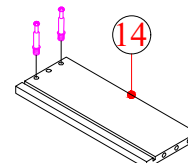
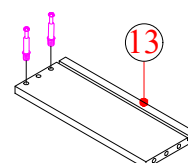
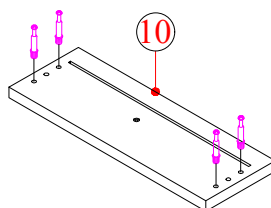
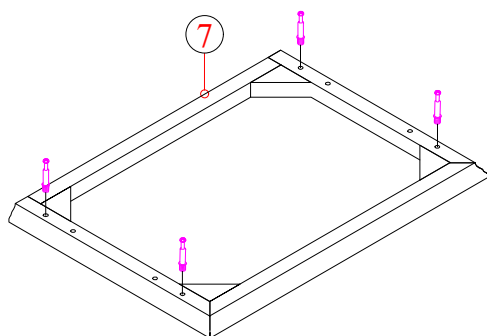
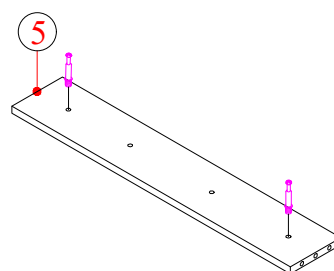
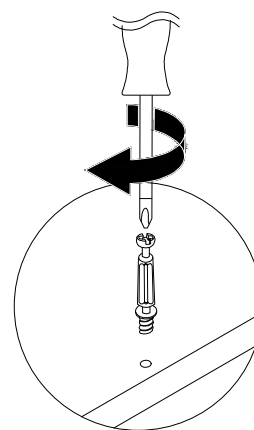
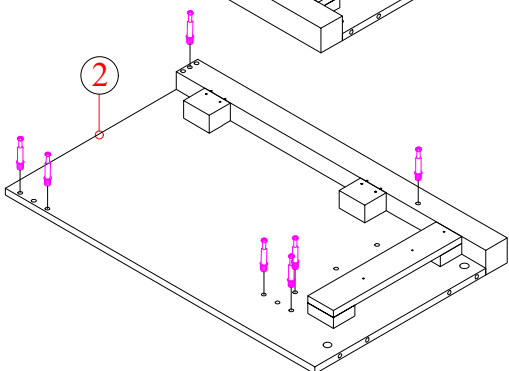
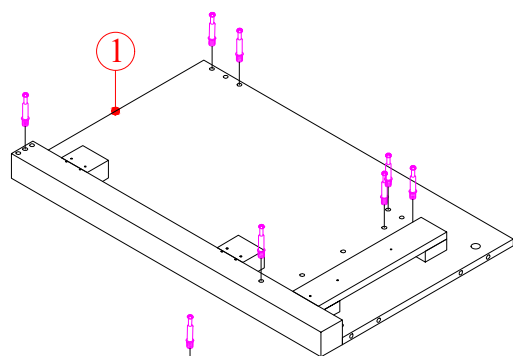
HARDWARE LIST	
A  28PCS	

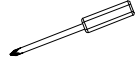

- Insert the Cam Screw into the shelves above

STEP 2

HARDWARE LIST			
G	 X	2PCS	
H		6PCS	

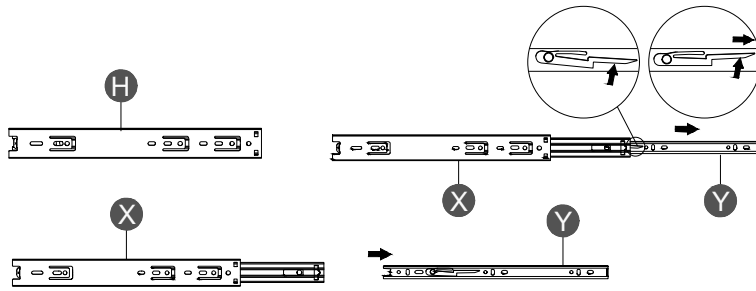

Keep pressing here, then pull out to divide the slide.

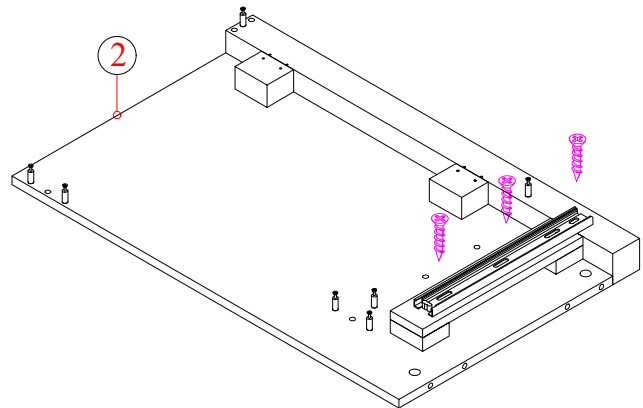
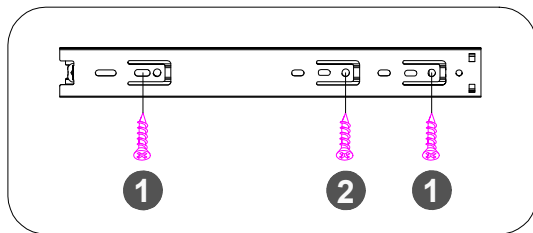
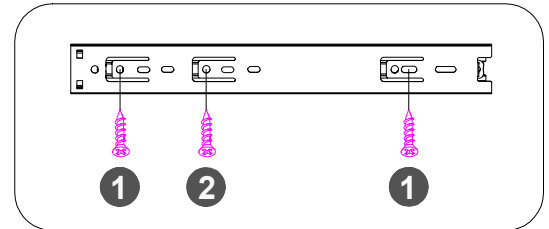
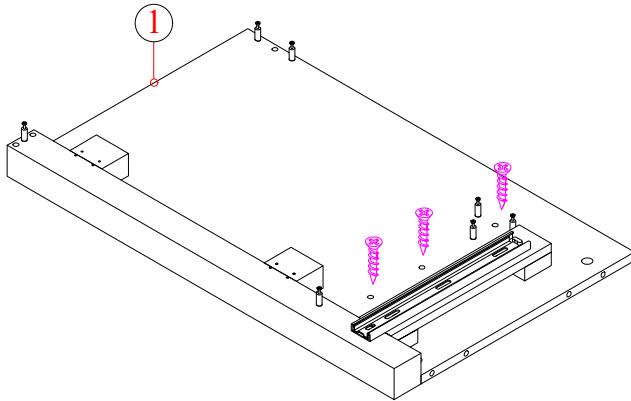

- Refer to the illustration to fix the Slide rails to theboard #1 and #2 with screws.

STEP 3

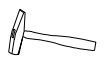
HARDWARE LIST			
I		14PCS	

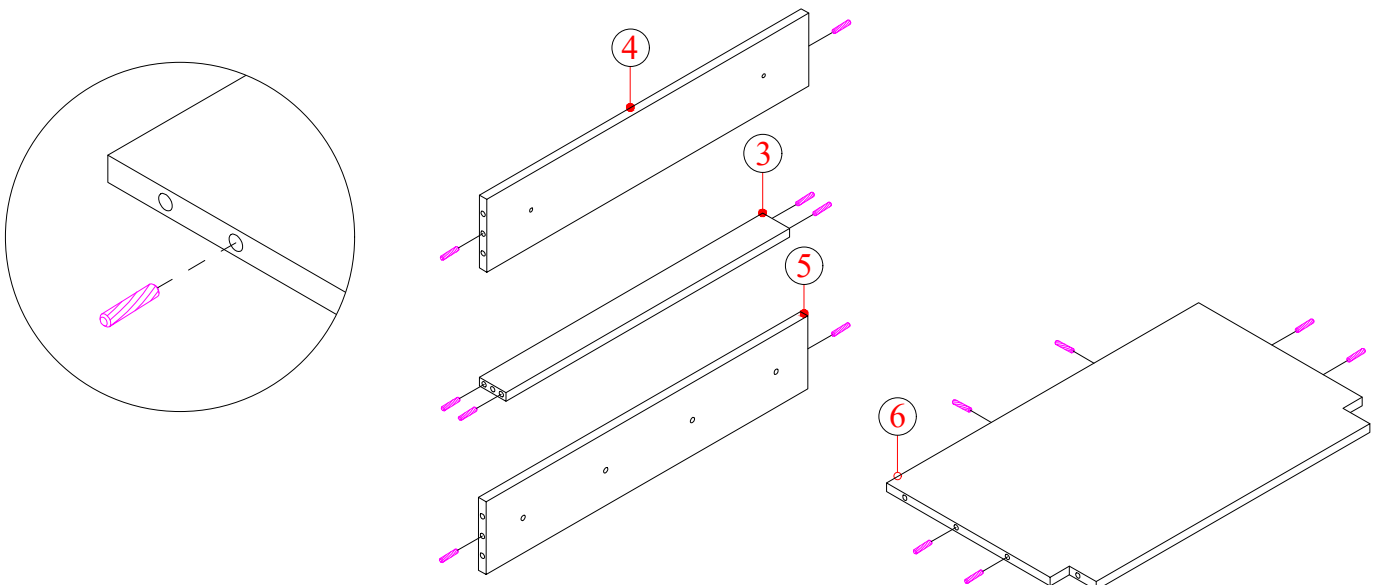

- Insert the wooden dowel pins into the shelves

STEP 4

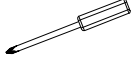
HARDWARE LIST			
A		2PCS	

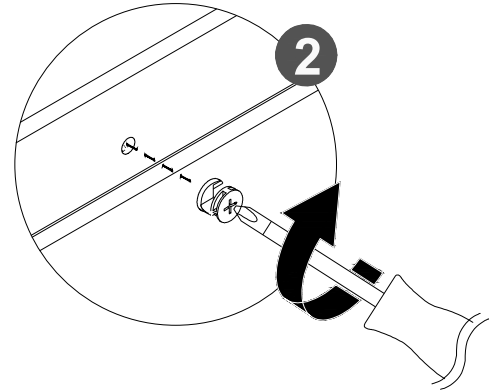
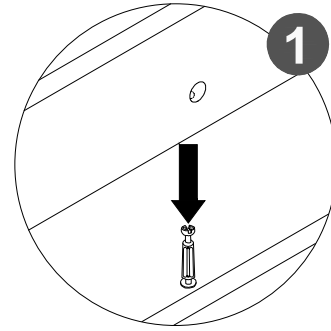
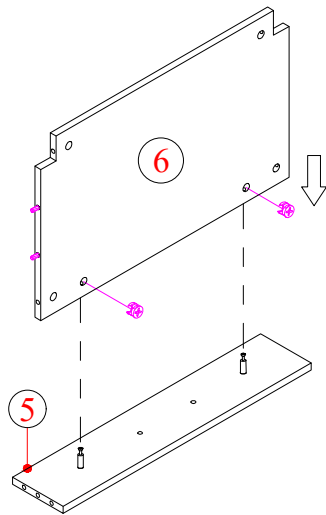

- Insert shelves #5 and #6 downwards to their corresponding positions. Then tighten the cam lock.

STEP 5

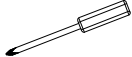
HARDWARE LIST			
A		14PCS	

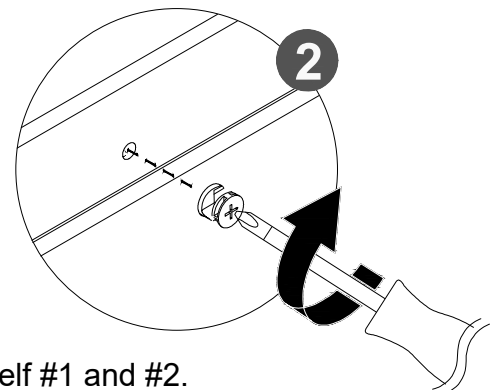
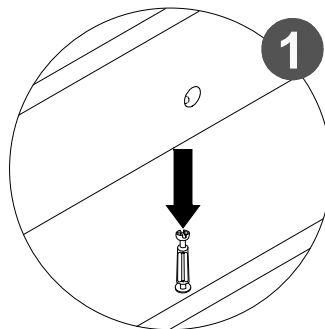
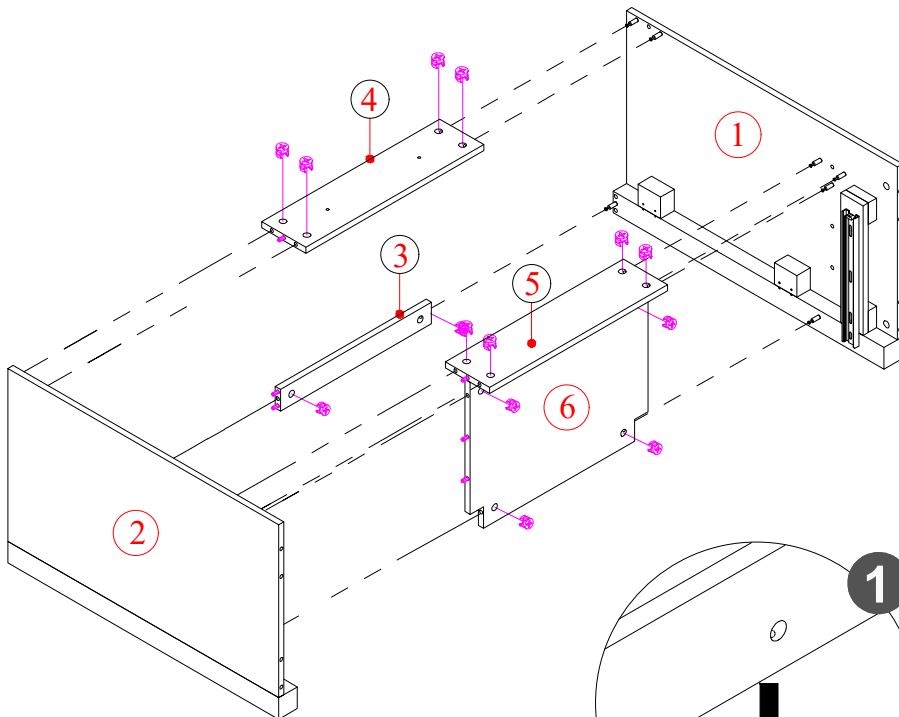

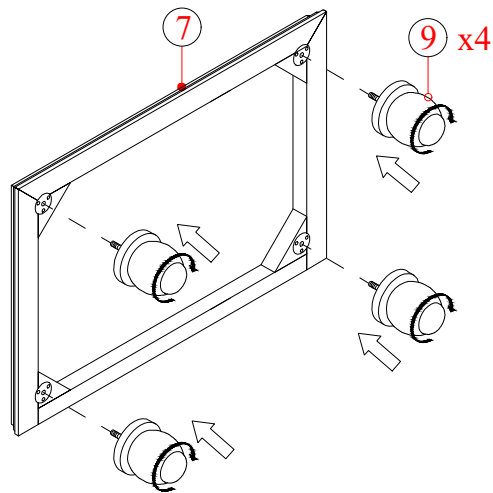

- Refer to the illustration, already assembled #3,#4,#5,#6 on the shelf #1 and #2. Then tighten the cam lock.

STEP 6

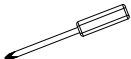

- Rotate clockwise the #9 into frame #7

STEP 7



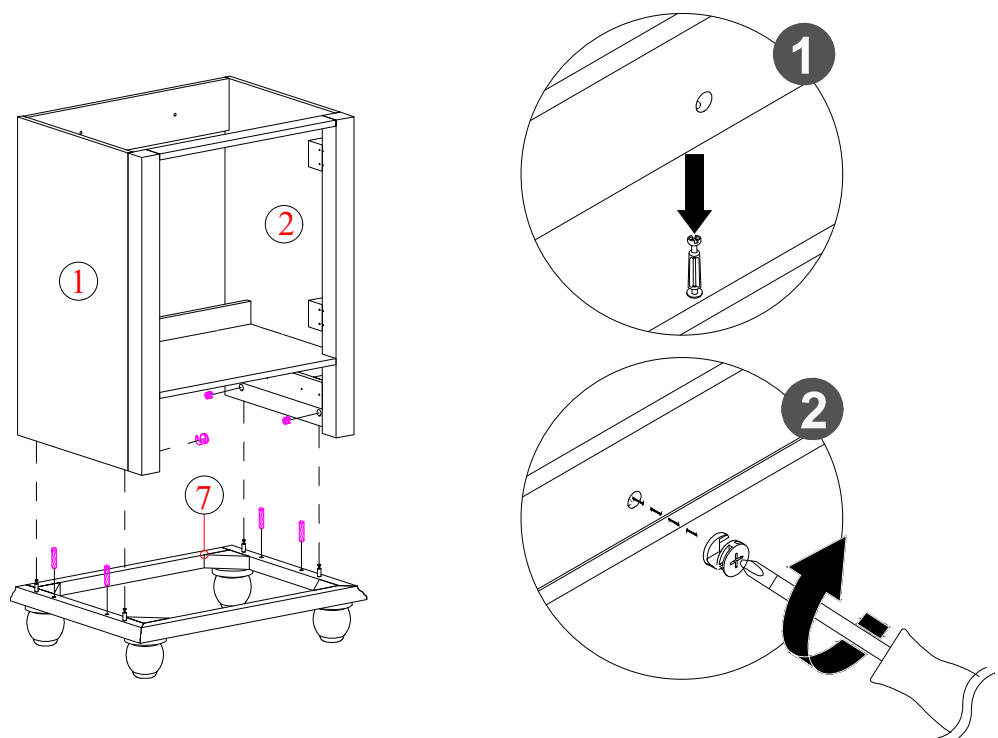

HARDWARE LIST			
A		4PCS	
I		4PCS	



- Insert the wooden dowel pins into the frame #7
- Insert shelves #1 and #2 downwards to their corresponding positions. Then tighten the cam lock.

STEP 8

HARDWARE LIST

F		4PCS
E		2PCS
B		1PC
D		1PC

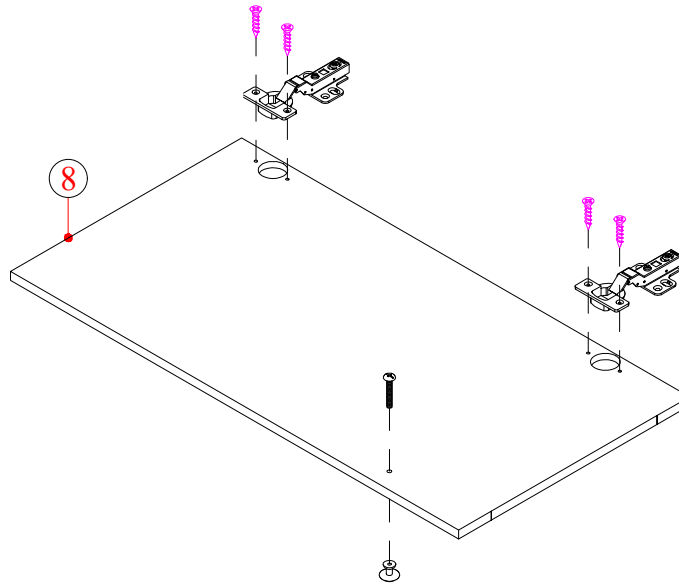
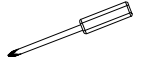

- Use Screws to install the handle and apply Screws to fix the hinge on the shelf #8.

STEP 9

HARDWARE LIST

F		8PCS
---	---	------

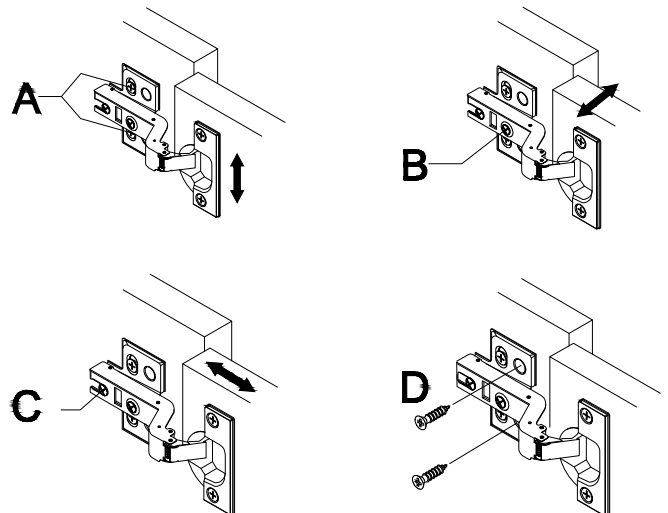
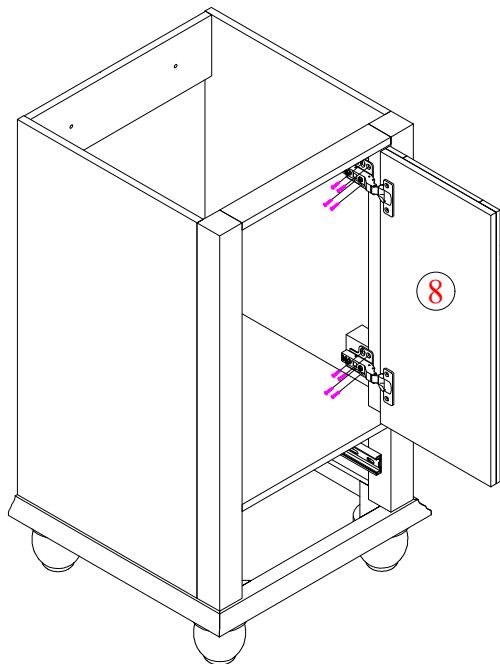
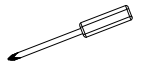



A. Height adjustment
C. Depth adjustment

B. Side to side adjustment
D. After adjustment A/B/C, tighten screws

- To ensure proper cabinet alignment, refer to the above illustrations for instructions about adjusting the cabinet height, depth and lateral movement.

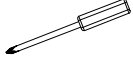

STEP 10

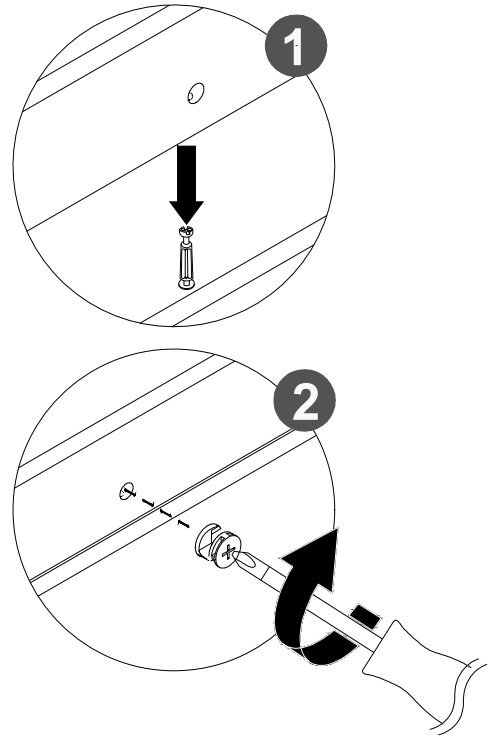
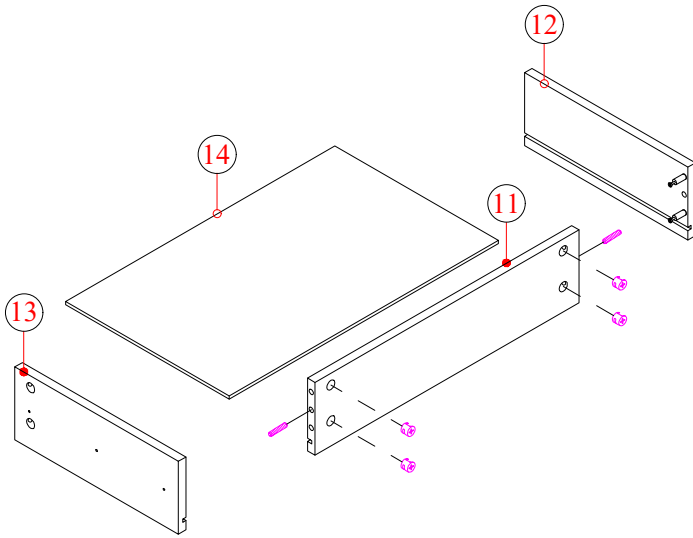
HARDWARE LIST			
A		4PCS	
I		2PCS	



- Insert the wooden dowel pins into the panel #11
- Insert shelves #11,#12, #13 and #14 to their corresponding positions. Then tighten the cam lock.

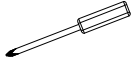

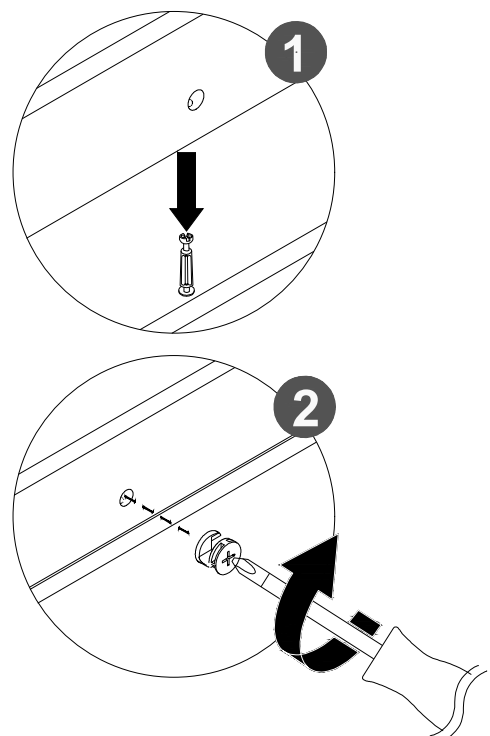
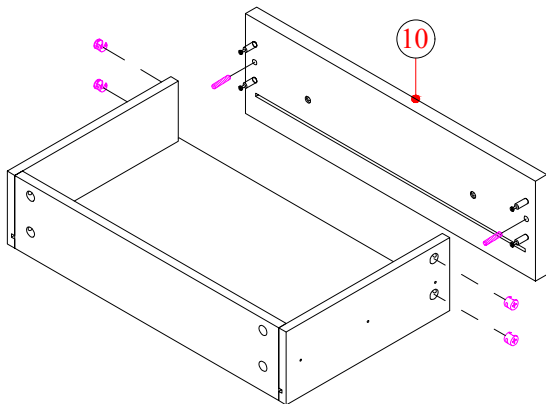

STEP 11

HARDWARE LIST			
A		4PCS	
I		2PCS	

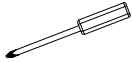

- Insert the wooden dowel pins into the panel #10
- Insert drawer panel to their corresponding positions. Then tighten the cam lock.

STEP 12

HARDWARE LIST			
B		1PC	
C		1PC	
G		2PCS	
H		6PCS	

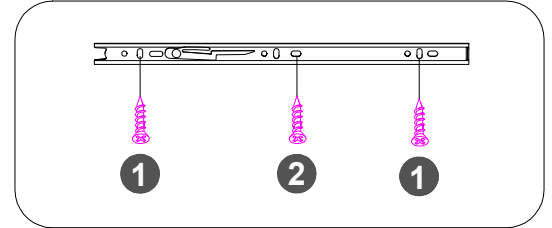
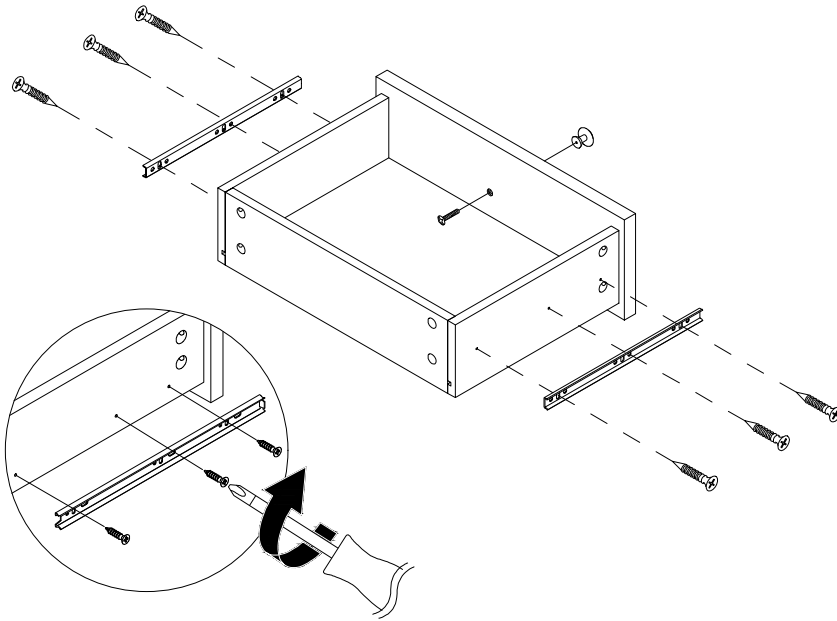

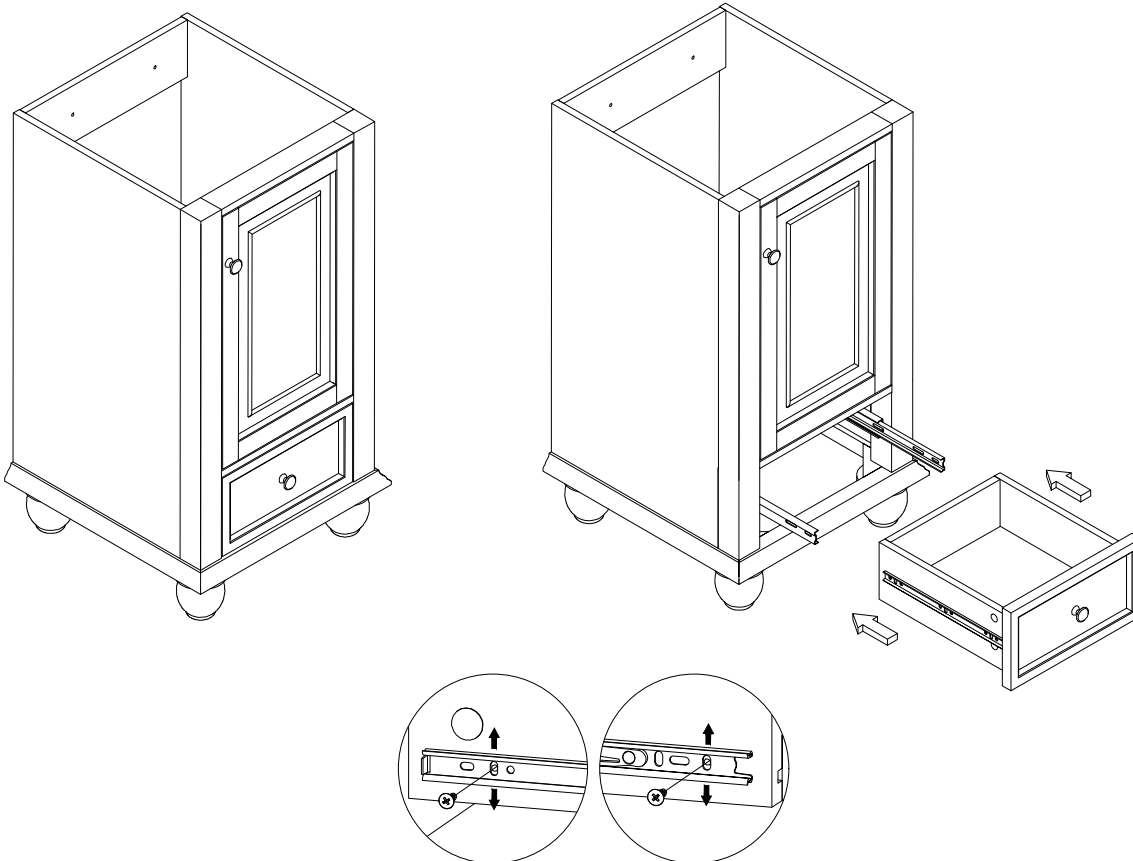

- Refer to the illustration, Apply Screws to fix the Slides on the panel #12, #13.
- Use Screws to install the handle

STEP 13



- If the drawers are not in the same level, please adjust the screws in the drawer box.
- Assembled drawers are loaded onto cabinets.

STEP 14

HARDWARE LIST		
J		2PCS
J		2PCS
J		2PCS

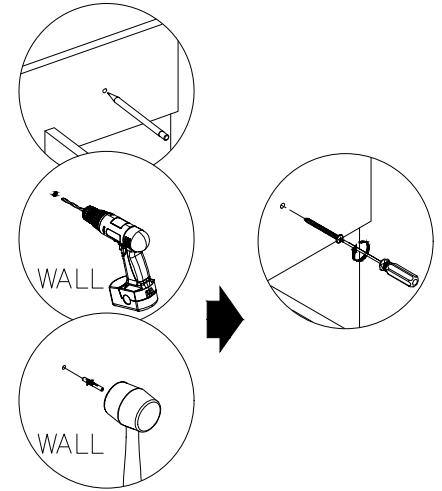
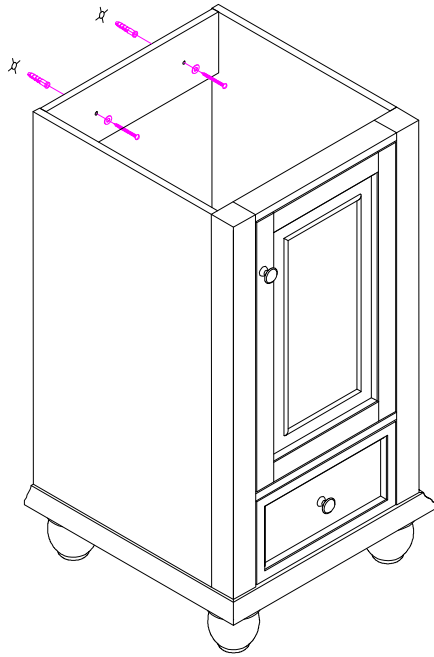

- Refer to the illustration, Draw the spacing between the walls on the cabinet, punch holes in the wall, and fix the cabinet to the wall with screws.

STEP 15

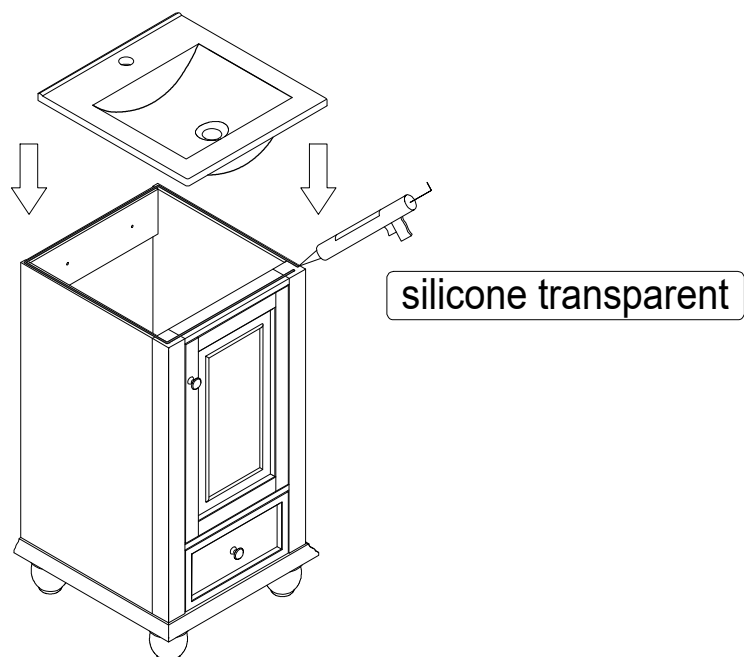



Thank you very much for purchasing from us.

We have always been trying to provide the best service and reliable products for every customer.

We sincerely hope you will be satisfied with our products and leave us FIVE STARS and POSITIVE feedback/review in our page.

However, accident may happen sometimes, please contact us to resolve any issue before leaving a negative feedback.

Many thanks and welcome to our shop again!

Contact number: (323)-393-8260

E-mail: service@eclifeusa.com