

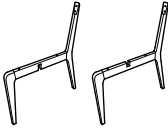

ASSEMBLY INSTRUCTION

**NOTE: THIS ITEM NOT RECOMMENDED FOR COMMERCIAL USE
KEEP THIS DOCUMENT FOR REFERENCE IN CASE PARTS ARE NEEDED
DO NOT TIGHTEN SCREWS UNTIL COMPLETELY ASSEMBLED**

HARDWARE LIST			
NO		DESCRIPTION	QTY
1		JCBC BOLT M6 x 60MM	5 PCS
2		JCBC BOLT M6 x 25MM	4 PCS
3		SPRING WASHER M6	9 PCS
4		WOODEN BUTTON	4 PCS
5		ALLEN KEY M4 x 110MM	1 PC

PART LIST			
NO		DESCRIPTION	QTY
A		CHAIR BACK	1
B		LEG (R/L)	2
C		WOODEN SEAT	1

ASSEMBLY INSTRUCTION

Step 1

Assemble Chair Base Part (B) as shown below.

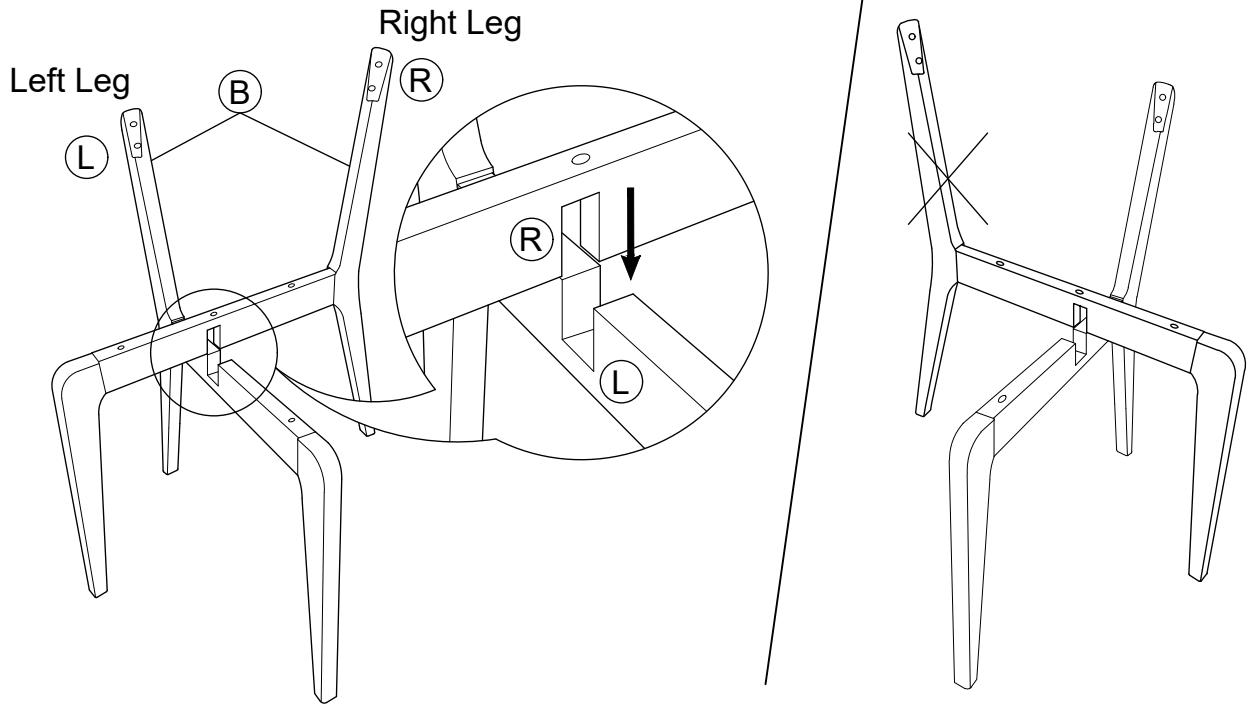

Step 2

Attach Chair Base to Seat Part (C).
Tighten hardware to 80% in this step.

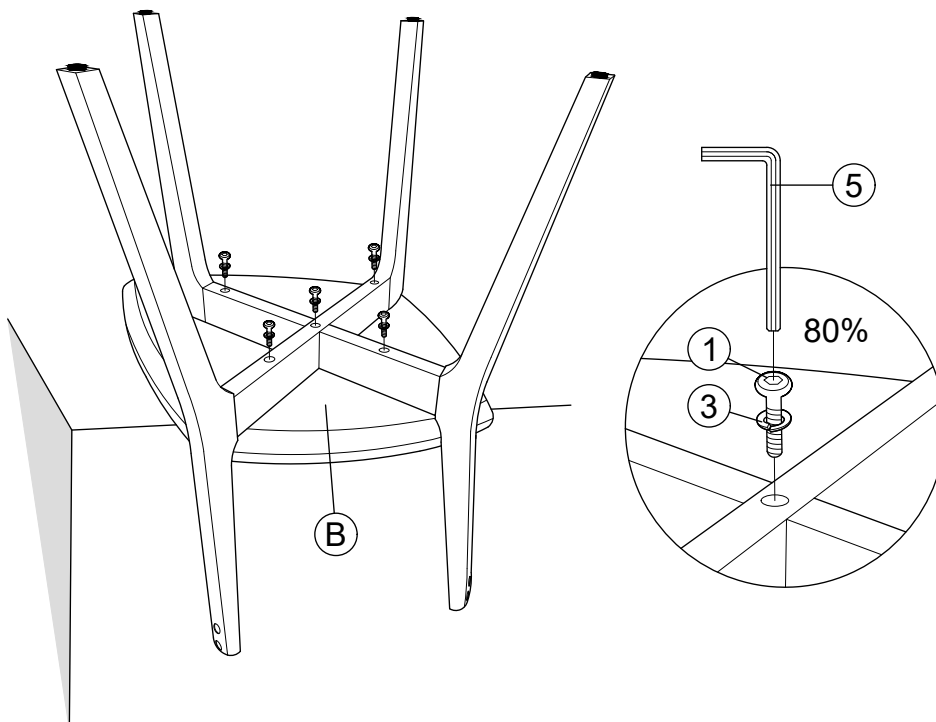

ASSEMBLY INSTRUCTION

Step 3

Attach Chair Back Part (A).

Tighten hardware to 80% in this step.

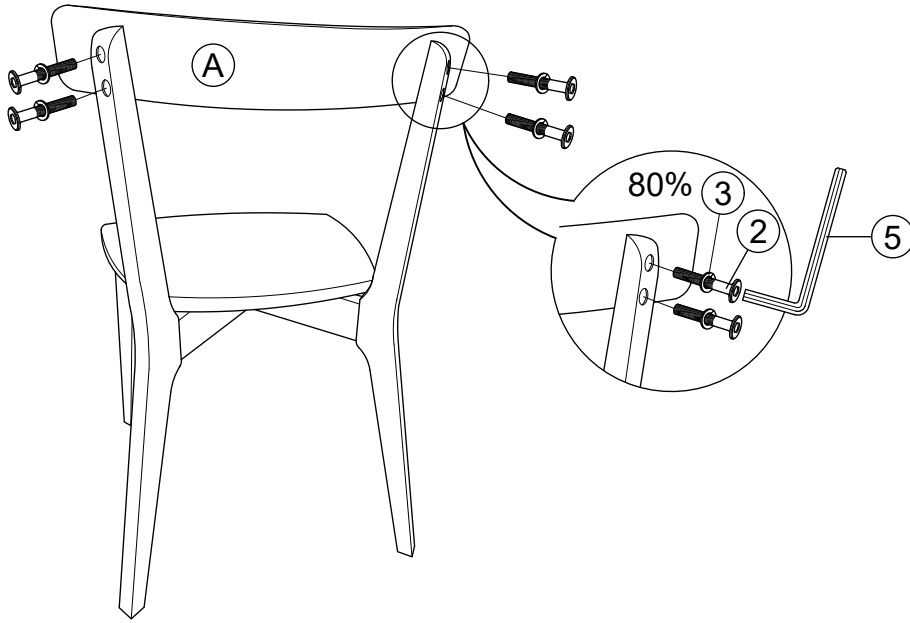

Step 4

Tighten all hardware to 100%.

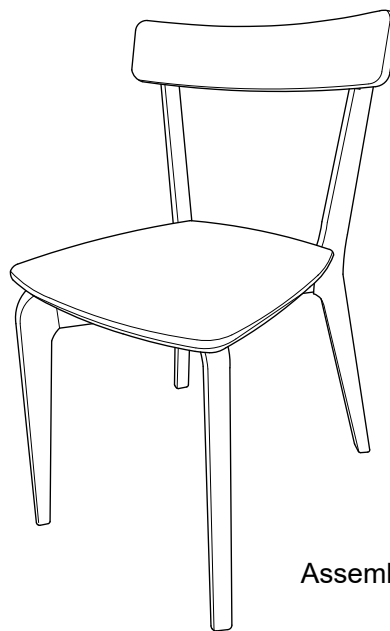

Assembly Completed