







Assembly Sheet

COFFEE TABLE

NO.	Illustration	Description	QTY/QTE	NO.	Illustration	Description	QTY/QTE
A		shelf	1	B		leg	2
C		cross brace	1	D		screw M6*12	4
E		screw M6*35	6	F		Allen Key	1
G		adjustable foot	4				

① insert the C to the leg B and fixed with screw D, then screw the adjustable foot (G) to the leg B

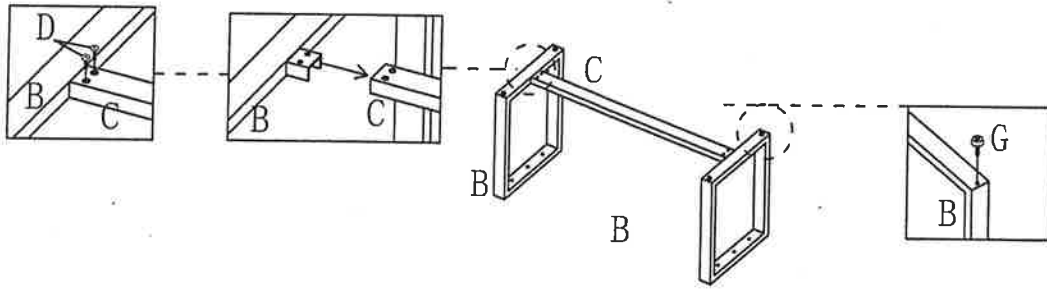

② Attach the shelf (A) to the legs (B) using screw E

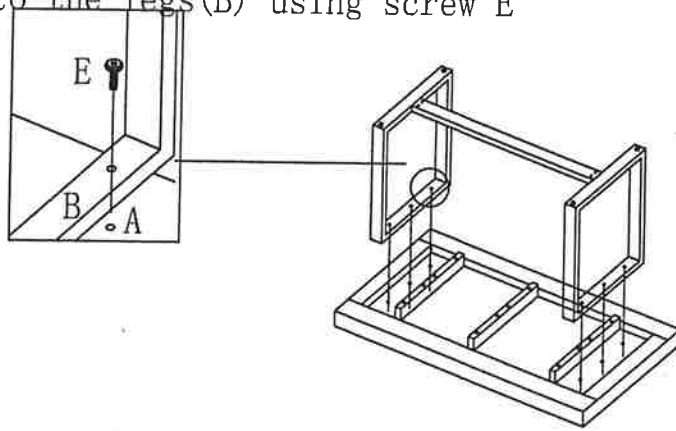

③

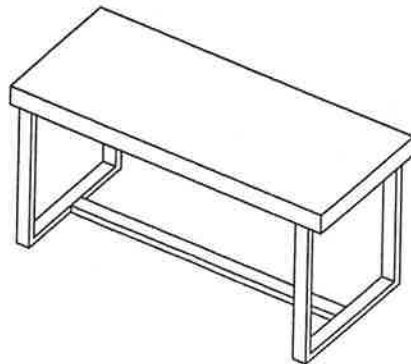

Feuille D'assemblage

COFFEE TABLE

NO.	Illustration	Description	QTY/QTE	NO.	Illustration	Description	QTY/QTE
A		Étagère	1	B		jambe	2
C		cross brace	1	D		Vis M6*12	4
E		Vis M6*35	6	F		clé Allen	1
G		pied réglable	4				

- ① Insérer le C sur la jambe B et fixer avec la vis D, visser le pied réglable (G) à la jambe B

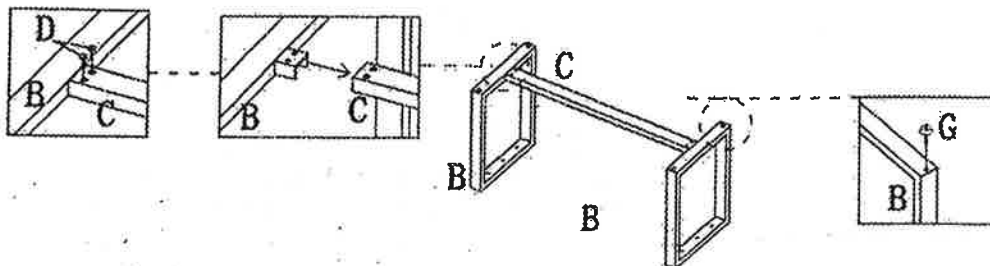

- ② Fixez l'étagère (A) aux pieds (B) à l'aide de la vis E

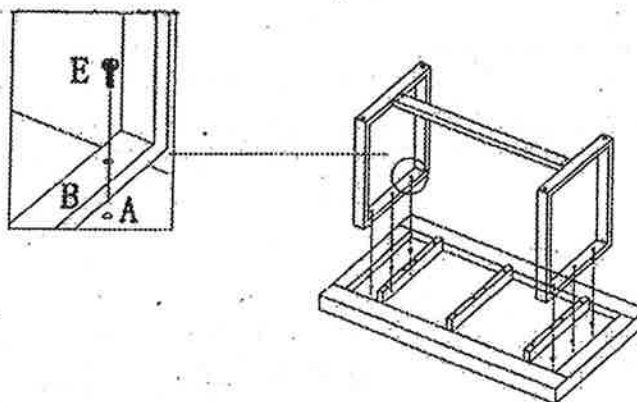



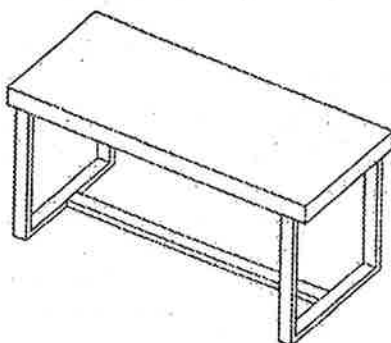



③



Assembly Sheet

END TABLE

NO.	Illustration	Description	QTY/QTE	NO.	Illustration	Description	QTY/QTE
A		shelf	1	B		legs	2
C		cross brace	1	D		screw M6*12	4
E		screw M6*35	6	F		Allen Key	1
G		adjustable foot	4				

① insert the cross brace C to the legs B with screw D, then screw the adjustable foot (G) to B

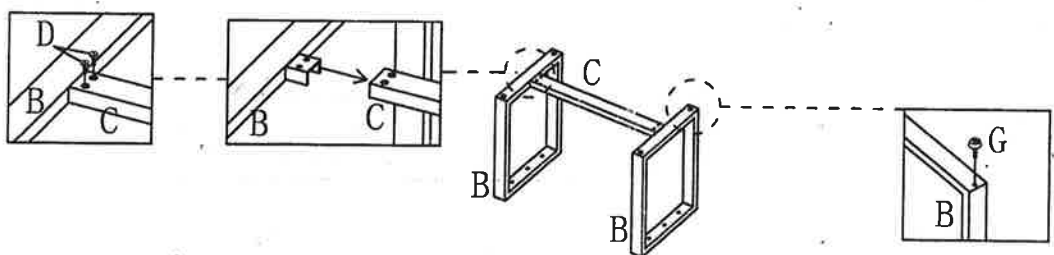

② Attach the shelf (A) to the legs (B) using screw E

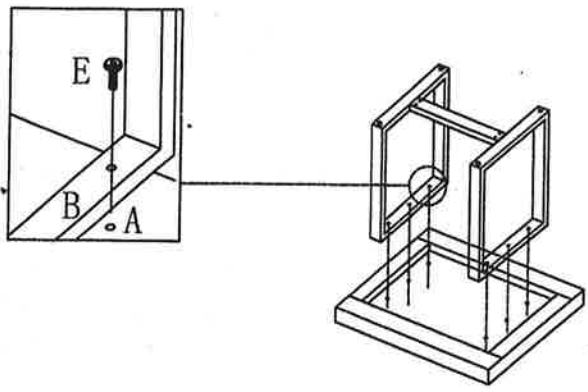

③

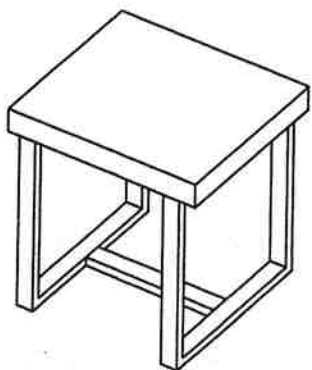

Feuille D'assemblage

FIN TABLE

NO.	Illustration	Description	QTY/QTE	NO.	Illustration	Description	QTY/QTE
A		Étagère	1	B		jambes	2
C		cross brace	1	D		Vis M6*12	4
E		Vis M6*35	6	F		clé Allen	1
G		ped réglable	4				

① Insérez la traverse C aux jambes B avec la vis D. Ensuite, vissez le réglage pied (G) à B.

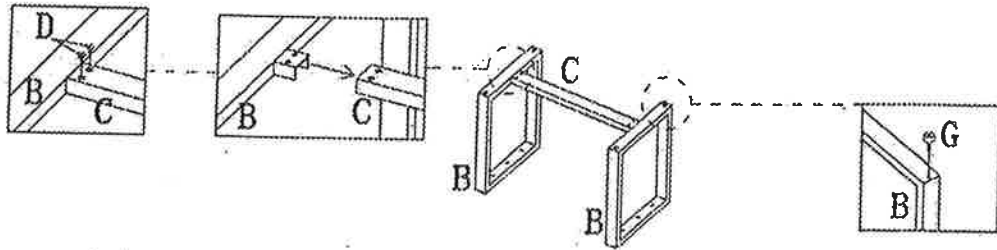

② Fixer le plateau (A) sur les branches (B) en utilisant la vis E.

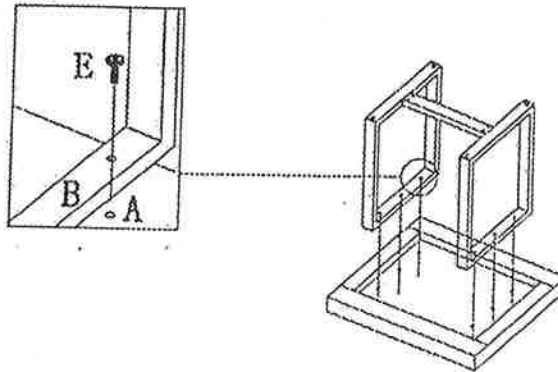

③

