

CEILING FAN

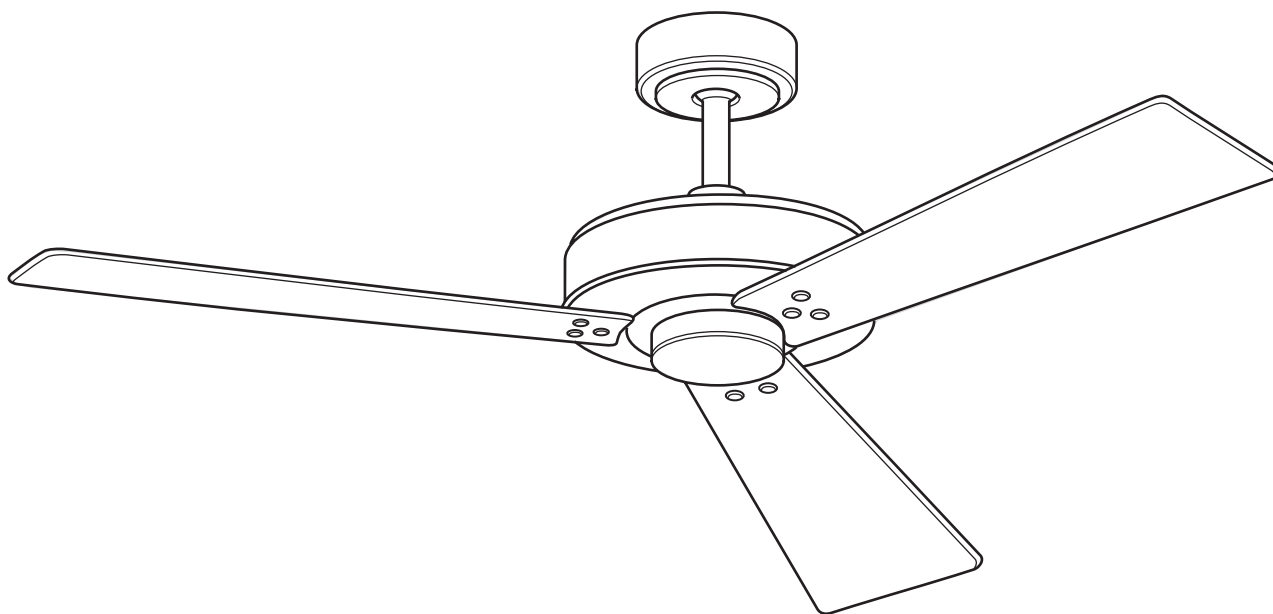

52" Ceiling Fan Owner's Manual

USE AND CARE GUIDE

Table of Contents

Section	Page
Safety Instructions	2
1. Unpacking Instructions	3-4
2. Electrical Requirements	4
3. Ceiling Fan Assembly	5-9
4. How to Hang Your Ceiling Fan	10-11
5. How to Wire Your Ceiling Fan	12-13
6. Final Assembly	14
7. Installing the Wall Control	15-16
8. Maintenance	16

Section	Page
9. Using Your Ceiling Fan	17
10. Energy Efficient Use of Ceiling Fans	18
11. Troubleshooting	18

READ AND SAVE THESE INSTRUCTIONS

Safety Instructions

WARNING

TO REDUCE THE RISK OF FIRE, ELECTRICAL SHOCK, OR INJURY TO PERSONS, OBSERVE THE FOLLOWING:

- Use this unit only in a manner intended by the manufacturer. If you have questions, contact the manufacturer.
- Before servicing or cleaning unit, switch power off at service panel and lock service panel disconnecting means to prevent power from being switched on accidentally. When the service disconnecting means cannot be locked, securely fasten a warning device, such as a tag, to the service panel.

- Read your owner's manual carefully and keep it for future reference.
- Be careful of the fan and blades when cleaning, painting, or working near the fan. Always turn off the power to the ceiling fan before servicing.
- Do not put anything into the fan blades while they are turning.
- Do not operate reversing switch until fan blades have come to a complete stop.

Additional Safety Instructions for Installation

- To avoid possible shock, be sure electricity is turned off at the fuse box before wiring, and do not operate fan without blades.
- All wiring must be in accordance with the National Electrical Code "ANSI/NFPA 70-2017" and Local Electrical Codes. Use the National Electrical Code if Local Codes do not exist. The ceiling fan must be grounded as a precaution against possible electrical shock. Electrical installation should be made or approved by a licensed electrician.

- The outlet box and joist must be securely mounted and capable of reliably supporting at least 50 pounds. Use only U.L. outlet boxes listed as "Acceptable for Fan Support of 22.7kg. (50 lbs.) or less", and use the mounting screws provided with the outlet box. Most outlet boxes commonly used for support of light fixtures are not acceptable for fan support and may need to be replaced. Consult a qualified electrician if in doubt.
- The downrod furnished with the fan provides the minimum recommended floor to fan blade clearance for an 8 foot ceiling.

CAUTION

To reduce the risk of injury, install the fan so that the blades are at least 7 ft. (2.1m) above the floor.

- Follow the recommended instructions for the proper method of wiring your ceiling fan. If you do not know enough about electrical wiring, have your fan installed by a licensed electrician.

NOTE: This fan is suitable for use with solid-state speed controls.

NOTE: All set screws must be checked and re-tightened where necessary before installation.

WARNING

To reduce the risk of electrical shock, this fan must be installed with an isolating wall control/switch.

To reduce the risk of fire or electrical shock, this fan should only be used with fan speed control, Model No. FR-7861LMA-02, manufactured by Rhine Electric Co., Ltd.

This product is designed to use only those parts supplied with this product and/or any accessories designated specifically for use with this product.

To reduce the risk of personal injury, do not bend the blade flange when installing the blade flanges, balancing the blades or cleaning the fan. Do not insert foreign objects in between rotating fan blades.

1. Unpacking Instructions

⚠ WARNING

Do not install or use fan if any part is damaged or missing.

⚠ WARNING

This product is designed to use only those parts supplied with this product and/or any accessories designated specifically for use with this product.

1.1

Check to see that you have received the following parts:

NOTE: If you are uncertain of part description, refer to exploded view illustration.

HARDWARE CONTENTS

Part	Description	Quantity
1	Threaded Studs, #8-32 x 1-1/4"	2
2	Lockwashers, External Tooth, #8	2
3	Knurled Knobs, #8-32	2
4	Clevis Pin	1
5	Hairpin Clip	1
6	Wire Connectors	5
7	Washer Head Screws #8-32 x 0.312"	10
8	Oval Head Countersunk Screws 1/4-20 x .500" Nyloc	7
9	Pan Head Screw #6-32 x 0.312" (Spare)	1
10	Flat Head Screws #6-32 x 0.375"	4

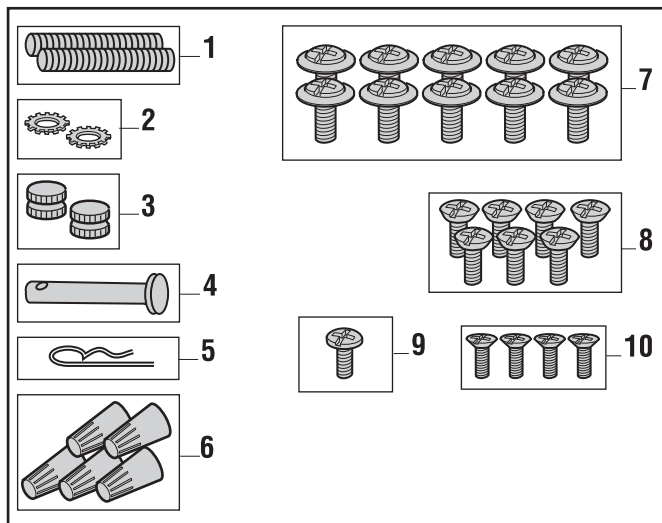

PACKAGE CONTENTS

Part	Description	Quantity
A	Fan Motor Assembly	1
B	Hanger Bracket	1
C	Hanger Ball/4.5" Downrod	1
D	Ceiling Cover	1
E	Coupler Cover	1
F	Flange Sets	3
G	Decorative Blade Nuts	9
H	Blade Sets	3
I	Switch Housing Adapter	1
J	Switch Housing Cover	1
K	SW46W Wall Control	1

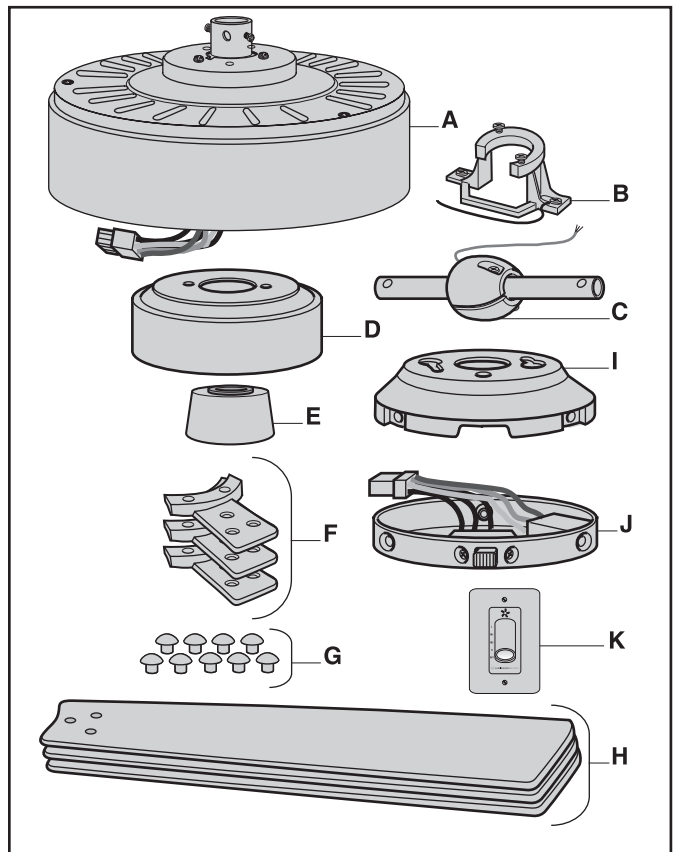

NOTE: Place the parts from the loose parts bags in a small container to keep them from being lost. If any parts are missing, contact your local retailer or catalog outlet for replacement before proceeding.

1.2

Remove the Fan Assembly from the protective plastic bag. Place the Fan Assembly into the upper foam pad with the top of the Motor facing up.

The upper foam pad serves as a holder for the Fan during the first stages of assembly.

1. Unpacking Instructions (Continued)

This Manual Is Designed to Make it as Easy as Possible for You to Assemble, Install, Operate and Maintain Your Ceiling Fan

Tools Needed for Assembly

One Phillips Head Screwdriver One Stepladder
One 1/4" Blade Screwdriver One Wire Stripper

Materials

Wiring outlet box and box connectors must be of type required by the local code. The minimum wire would be a 3-conductor (2-wire with ground) of following size:

<u>Installed Wire Length</u>	<u>Wire Size A.W.G.</u>
Up to 50 ft.	14
50-100 ft.	12

Your Ceiling Fan comes supplied with a Fan Wall Control. This system allows you to regulate your Ceiling Fan Speed.

WARNING

Before assembling your ceiling fan, refer to section on proper method of wiring your fan (page 12). If you feel you do not have enough wiring knowledge or experience, have your fan installed by a licensed electrician.

Controls (sold separately)

The RFCP Receiver and SR400/ SW405 Remote Control (sold separately) may be used with this 52" Keane Ceiling Fan. Controls are recommended for indoor use only.

2. Electrical Requirements

Your new Ceiling Fan will require a Grounded Electrical Supply Line of 120 Volts AC, 60 Hz, 15 Amp Circuit.

The Outlet Box must be securely Anchored and capable of withstanding a Load of at least 50 Pounds.

WARNING

To reduce the risk of fire, electric shock, or personal injury, mount fan to outlet box marked "Acceptable for Fan Support of 22.7kg. (50 lbs.) or less", and use screws supplied with outlet box. Most outlet boxes commonly used for support of light fixtures are not acceptable for fan support and may need to be replaced. Consult a qualified electrician if in doubt.

WARNING

Turning off wall switch is not sufficient. To avoid possible electrical shock, be sure electricity is turned off at the main fuse box before wiring. All wiring must be in accordance with National and Local codes and the ceiling fan must be properly grounded as a precaution against possible electrical shock.

If your Fan is to replace an Existing Ceiling Light Fixture, turn Electricity OFF at the Main Fuse Box at this time and remove the existing Light Fixture.

WARNING

To avoid fire or shock, follow all wiring instructions carefully.

Any electrical work not described in these instructions should be done or approved by a licensed electrician.

3. Ceiling Fan Assembly

3.1

Remove the Hanger Ball by loosening the Phillips Head Set Screw in the Hanger Ball until the Ball falls freely down the Downrod (Figure 1).

Remove the Pin from the Downrod, then remove the Hanger Ball (Figure 1).

Retain the Pin and Hanger Ball for reinstallation in Step 3.7.

NOTE: Do not loosen the Screw holding the Green Ground Wire.

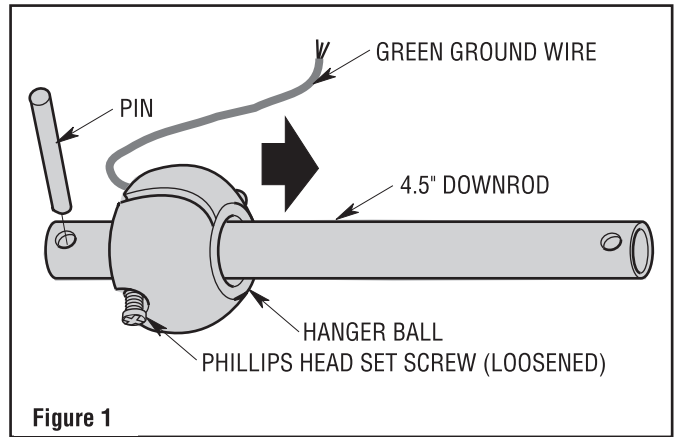

3.2

Separate, untwist and unkink the Two Motor Wires.

Route the Two Motor Wires through the Downrod (Figure 2).

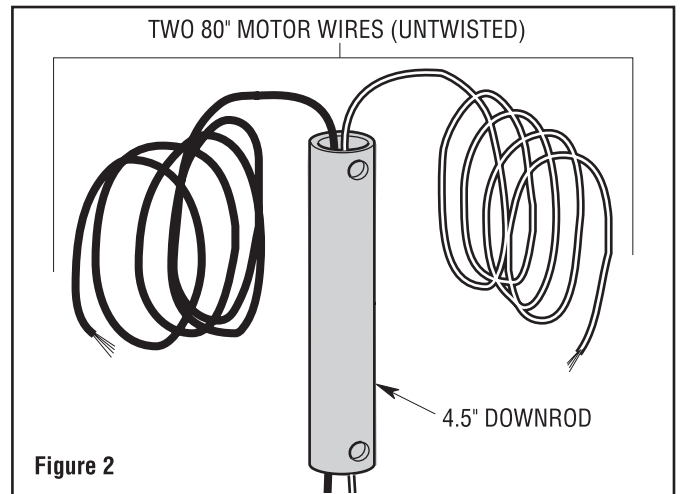

3.3

Loosen the Two Phillips Head Set Screws in the Motor Coupler for installation of the Downrod (Figure 3).

Seat the Downrod in the Motor Coupler (Figure 3).

Rotate and align the Downrod Holes with all the Holes in the Motor Coupler (Figure 3).

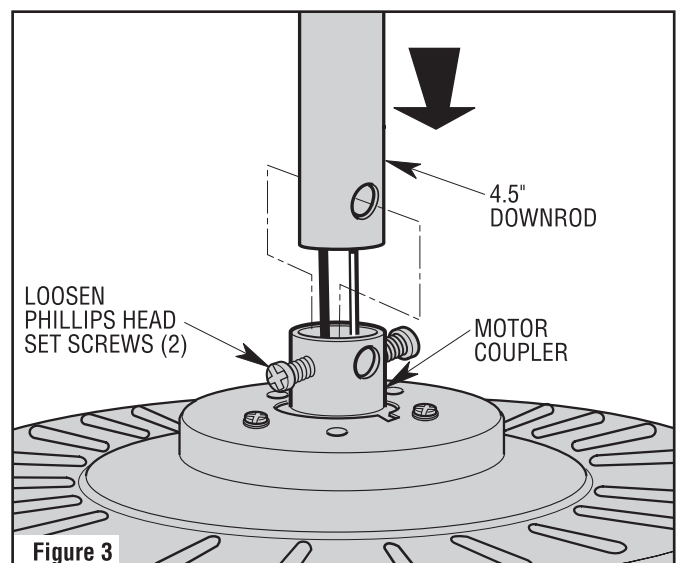

3. Ceiling Fan Assembly (Continued)

3.4

Align the Clevis Pin Holes in the Downrod with the Holes in the Motor Coupler.

Install the Clevis Pin and secure with the Hairpin Clip (Figure 4).

The Clevis Pin must go through the Holes in the Motor Coupler. It is critical that the Clevis Pin in the Motor Coupler is properly installed and securely tightened.

Retighten the Two Phillips Head Set Screws to secure the Downrod to the Motor (Figure 4).

⚠ WARNING

It is critical that the clevis pin and set screws in the motor coupler are properly installed and securely tightened. Failure to verify that the pin and set screws are properly installed could result in the fan falling.

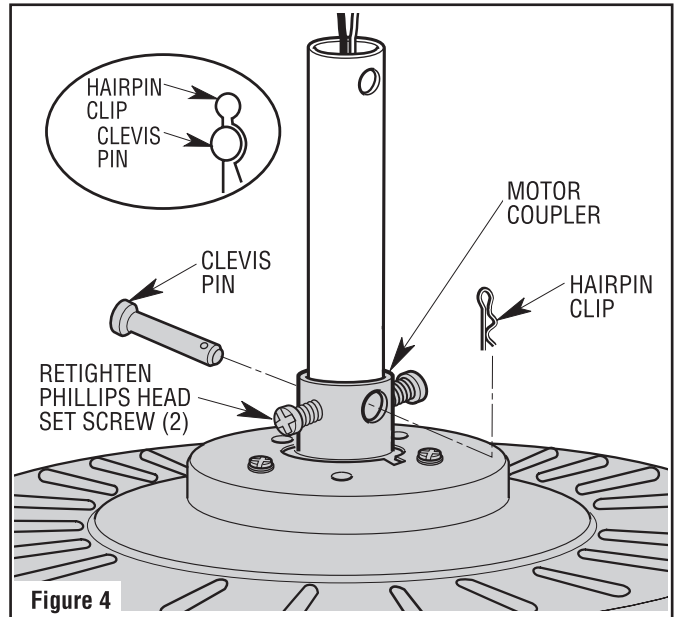

3.5

Make sure the Grommet is properly installed in the Coupler Cover, then slide the Coupler Cover on the Downrod until it rests on the Motor Housing (Figure 5).

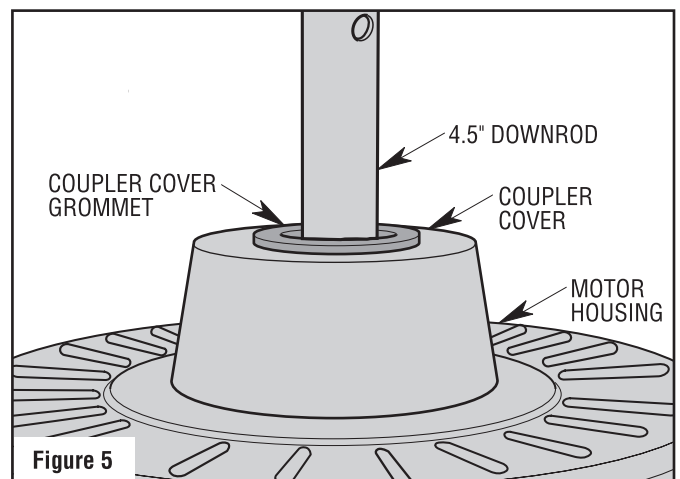

3.6

Place the Ceiling Cover over the Downrod (Figure 6).

Be sure that the Ceiling Cover and the Coupler Cover are both oriented correctly (Figure 6).

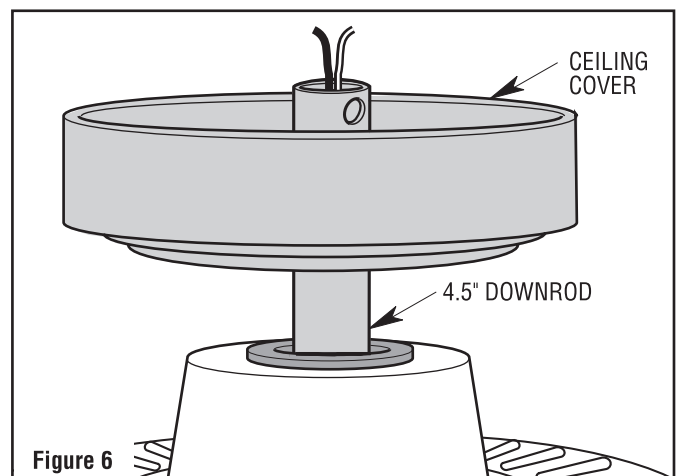

3. Ceiling Fan Assembly (Continued)

3.7

Route the Two Motor Wires through the Hanger Ball (Figure 7).

Reinstall the Hanger Ball on the Downrod as follows:

Position the Pin through the Two Holes in the Downrod and align the Hanger Ball so the Pin is captured in the Groove in the top of the Hanger Ball (Figure 7).

Pull the Hanger Ball up tight against the Pin and securely retighten the Phillips Head Set Screw in the Hanger Ball (Figure 7).

A loose Phillips Head Set Screw could create Fan wobble.

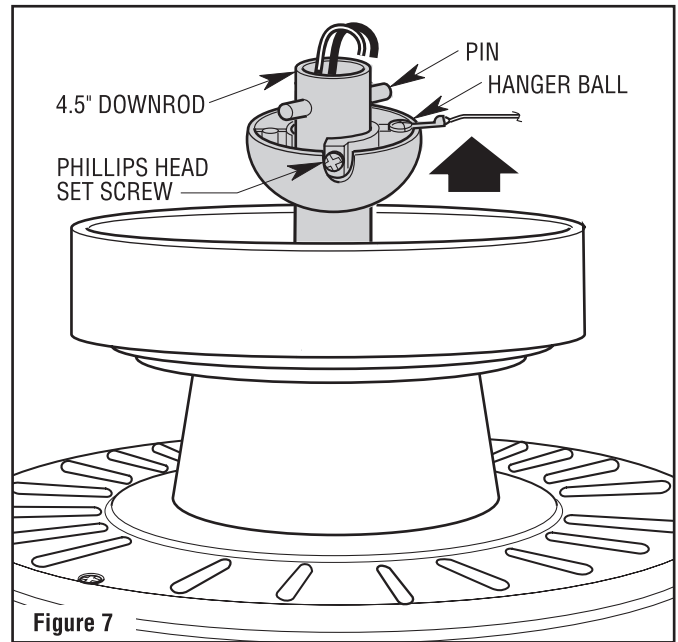

3.8

The Fan comes with Black and White Wires that are 80-inches long.

Measure up approximately 6 to 9-inches above top of Hanger Ball / 4.5" Downrod Assembly (Figure 8).

Cut off excess Wires and strip back insulation 1/2-inch from end of Wires.

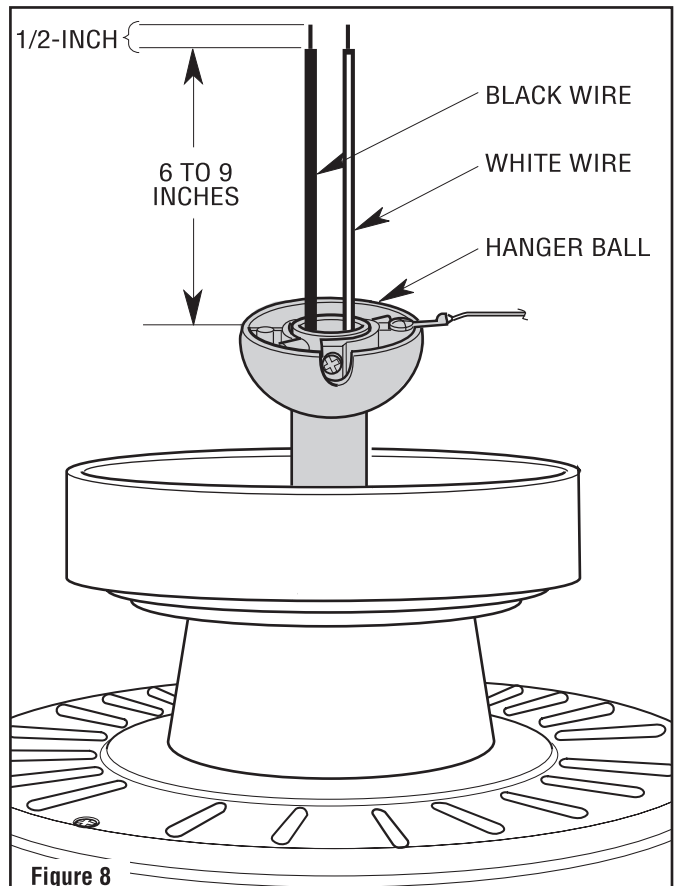

3. Ceiling Fan Assembly (Continued)

3.9

Turn the partially assembled Ceiling Fan upside down, place the Ceiling Fan onto the two carton styrofoam pieces, in preparation for final assembly (Figure 9).

Remove the Six Shipping Spacers and the Spacer Attachment Screws from the Motor before installation of Blade Assemblies (Figure 9).

Discard the Six Shipping Spacers and Spacer Screws.

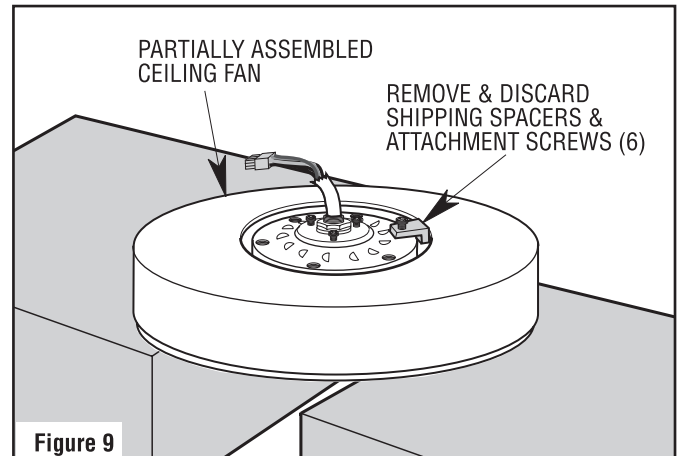

3.10

NOTE: Intermixing blades between fans can cause excessive wobble. Keep blades in original sets of three.

Place the Flange on the Blade (Figure 10).

Place the Decorative Blade Nut onto the underside of the Blade (Figure 10).

Tighten the #8-32 x 0.312" Washer Head Screw to secure (supplied in parts bag) the Blade and the Decorative Blade Nut (Figure 10).

Repeat this procedure for the other Two Flanges, Decorative Blade Nut and Blades.

Make sure all #8-32 x 0.312" Washer Head Screws are tighten securely to the Decorative Blade Nut to secure the Blade and Flange.

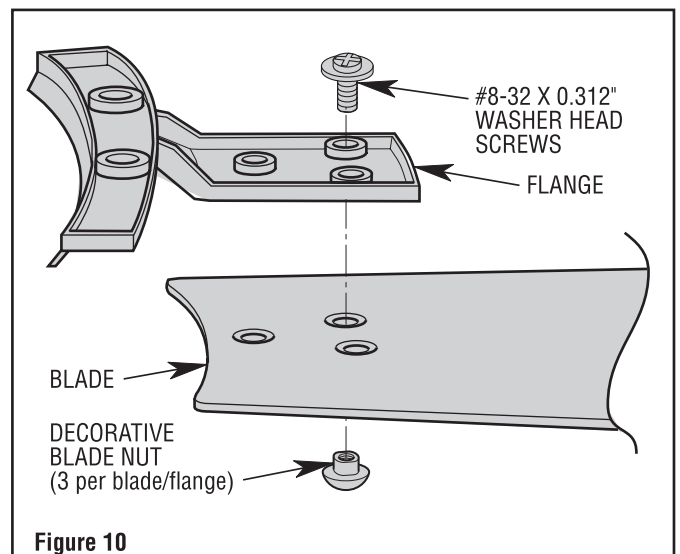

3.11

Loosely attach one Blade/Flange Assembly to the Motor Hub by securing the Two 1/4-20 x .500" Oval Head Countersunk Screws (Figure 11).

Repeat this procedure for other Two Blade Assemblies.

Tighten all the 1/4-20 x .500" Oval Head Countersunk Screws to the Motor Hub at this time.

NOTE: Take care not to scratch fan housing when installing blades.

⚠ WARNING

To reduce the risk of personal injury, do not bend the blade flange when installing the blade flanges, balancing the blades or cleaning the fan. Do not insert foreign objects in between rotating fan blades.

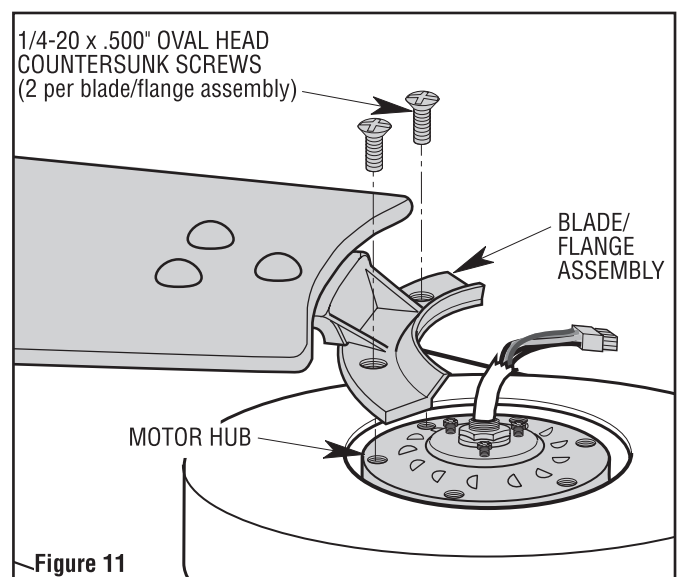

3. Ceiling Fan Assembly (Continued)

3.12

Remove One #6-32 x 0.312" Pan Head Screw from the Motor Hub and retain for later use.

Loosen the other Two #6-32 x 0.312" Pan Head Screws on the Motor Hub for the installation of the Switch Housing Adapter.

Place the Motor Hub Connector through the Center Hole of the Switch Housing Adapter.

Place the Switch Housing Adapter onto the Motor Hub, aligning the Three Screw Holes (Figure 12).

Rotate the Switch Housing Adapter Key Hole Slots Clockwise to engage Both Loosened Screws (Figure 12).

Reinstall the previous removed Screw.

Secure the Switch Housing Adapter to the Motor Hub by tightening the Three Switch Housing Screws.

Spare #6-32 x 0.312" Pan Head Screw supplied in parts bag, if needed.

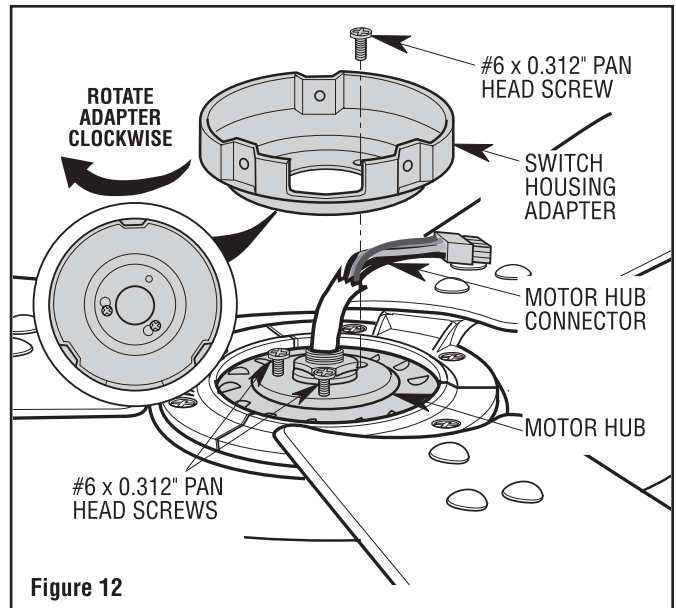

3.13

The Two Connectors are Keyed and Color-coded and must be mated correctly (same color-to-color) before they can be engaged.

Engage the Connector of the Switch Housing Cover with the Motor Hub Connector (Figure 13).

Make sure the Connector Latch closes properly.

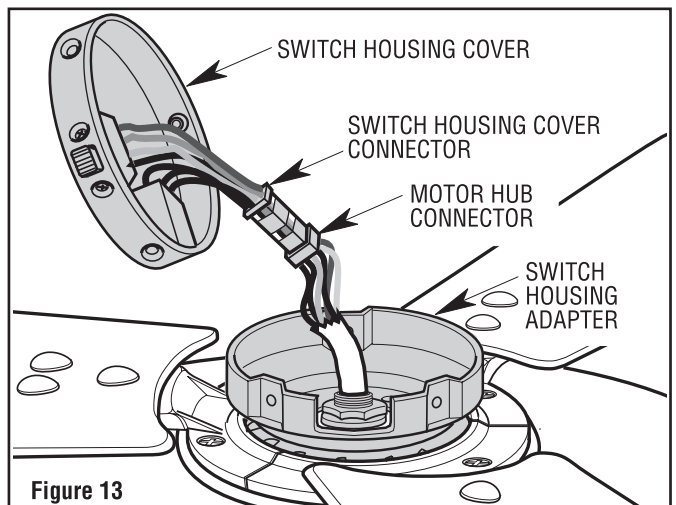

3.14

Tuck all the Wires and Connectors into the Switch Housing Adapter.

Position the Switch Housing Cover so that the Reverse Switch fits into the Large Slot of the Switch Housing Adapter (Figure 14).

Align the Three Screw Holes of the Switch Housing Cover.

Secure the Switch Housing Cover to the Switch Housing Adapter using the Three #6-32 x 0.375" Flat Head Screws (supplied in parts bag) (Figure 14).

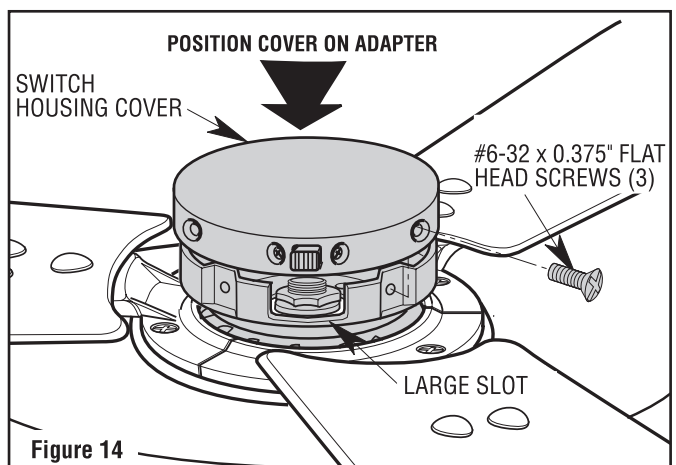

4. How to Hang Your Ceiling Fan

⚠ CAUTION

To reduce the risk of injury, install the fan so that the blades are at least 7 ft. (2.1m) above the floor (Figure 15).

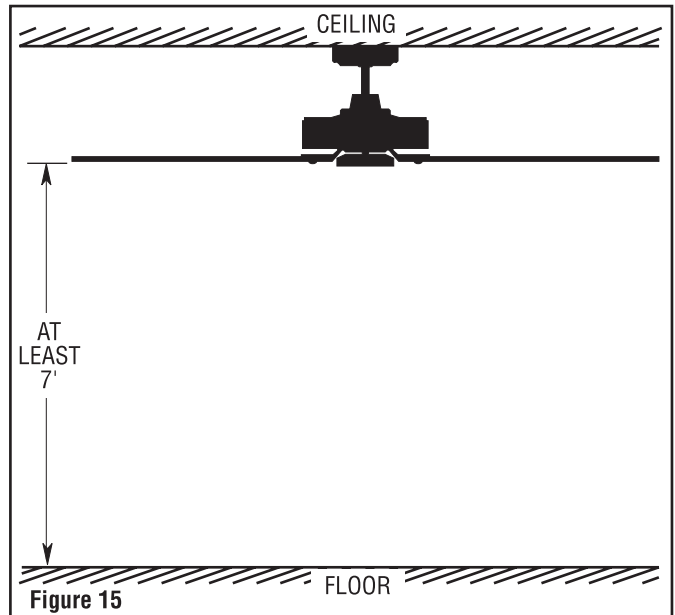

⚠ WARNING

The outlet box and joist must be securely mounted and capable of supporting at least 50 lbs. Use only a U.L. outlet box listed as “Acceptable for Fan Support of 22.7 kg. (50 lbs.) or less”.

⚠ WARNING

To reduce the risk of fire, electric shock, or personal injury, mount fan to outlet box marked “Acceptable for Fan Support of 22.7 kg. (50 lbs.) or less”, and use screws supplied with outlet box. Most outlet boxes commonly used for support of light fixtures are not acceptable for fan support and may need to be replaced. Consult a qualified electrician if in doubt.

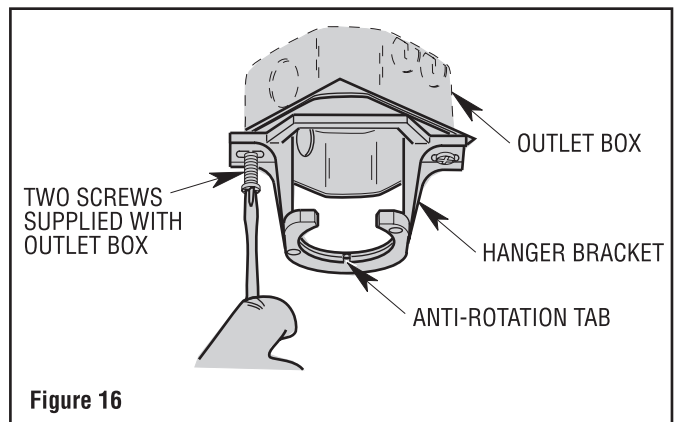

4.1

Securely attach the Hanger Bracket to the Outlet Box using the Two Screws supplied with the Outlet Box. (Figure 16).

⚠ WARNING

Hanger bracket must seat firmly against outlet box. If the outlet box is recessed, remove wall board until bracket contacts box. If bracket and/or outlet box are not securely attached, the fan could wobble or fall.

4. How to Hang Your Ceiling Fan (Continued)

4.2

Carefully lift the Fan and seat the Hanger Ball/Downrod Assembly on the Hanger Bracket that was just attached to the Outlet Box (Figure 17).

Be sure the Groove in the Ball is engaged with the Anti-Rotation Tab on the Hanger Bracket (Figure 17).

⚠ WARNING

Failure to seat tab in groove could cause damage to electrical wires and possible shock or fire hazard.

⚠ WARNING

To avoid possible fire or shock, do not pinch wires between the hanger ball/downrod assembly and hanger bracket.

NOTE: CEILING COVER, SUPPLY WIRES AND FAN WIRES OMITTED FOR CLARITY.

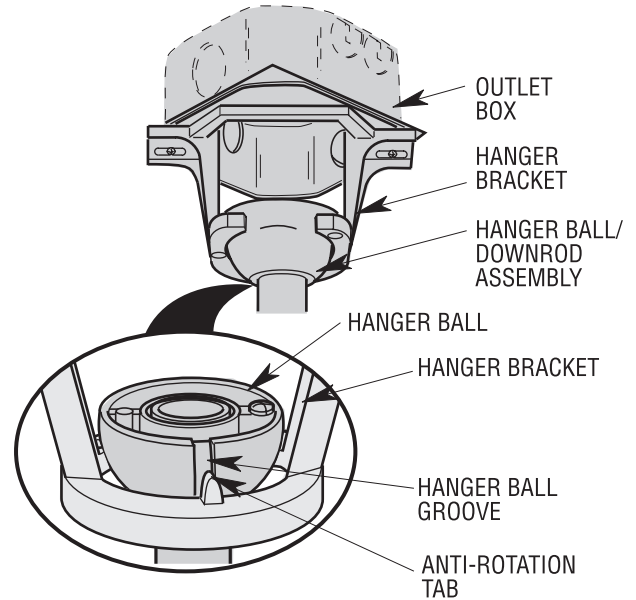

Figure 17

5. How to Wire Your Ceiling Fan

If you feel that you do not have enough electrical wiring knowledge or experience, have your fan installed by a licensed electrician.

⚠ WARNING

To avoid possible electrical shock, be sure electricity is turned off at the main fuse box before wiring.

NOTE: If you are not sure if the outlet box is grounded, contact a licensed electrician for advice, as it must be grounded for safe operation.

5.1

Connect the Green Ground Wire from the Hanger Ball and the Green Grounding Wire from the Hanger Bracket to the Grounding Conductor of Supply (this may be a bare wire or wire with green colored insulation). Securely connect Wires with Wire Connectors (supplied) (Figure 18).

⚠ WARNING

Turning off wall switch is not sufficient. To avoid possible electrical shock, be sure electricity is turned off at the main fuse box before wiring. All wiring must be in accordance with National and Local codes and the ceiling fan must be properly grounded as a precaution against possible electrical shock.

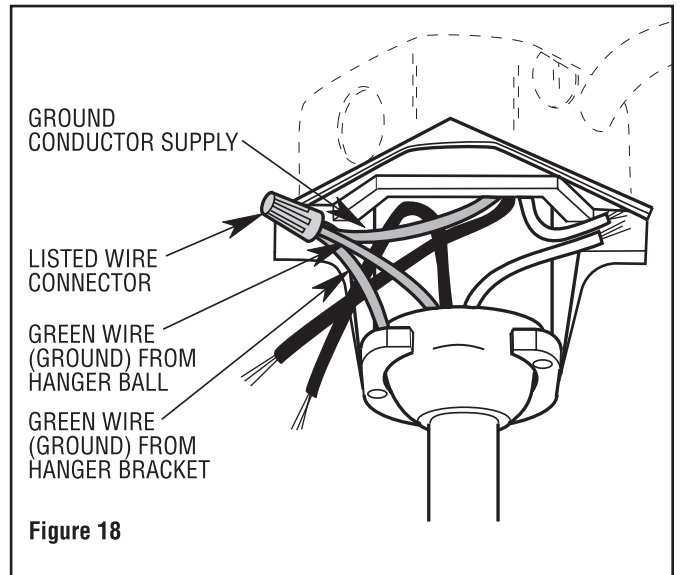

⚠ WARNING

This product is designed to use only those parts supplied with this product and/or any accessories designated specifically for use with this product.

5.2

Securely connect the Fan Motor White Wire to the Supply White (neutral) Wire using Wire Connector (supplied) (Figure 19).

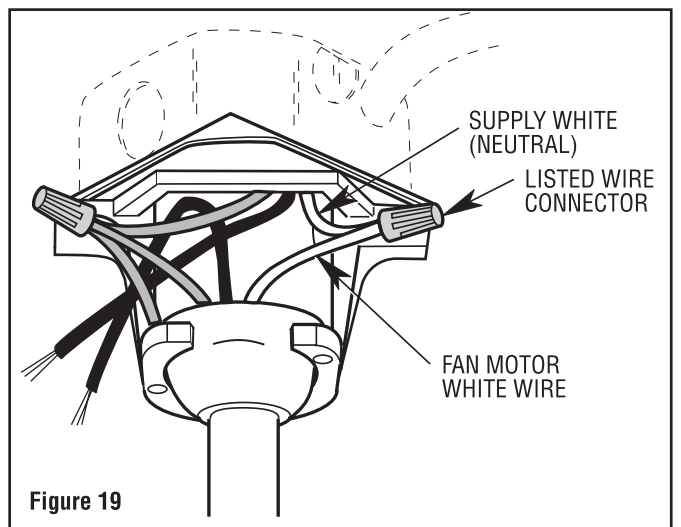

5. How to Wire Your Ceiling Fan (Continued)

5.3

Securely connect the Fan Motor Black Wire to the Supply Black (hot) Wire using Wire Connector (supplied) (Figure 20).

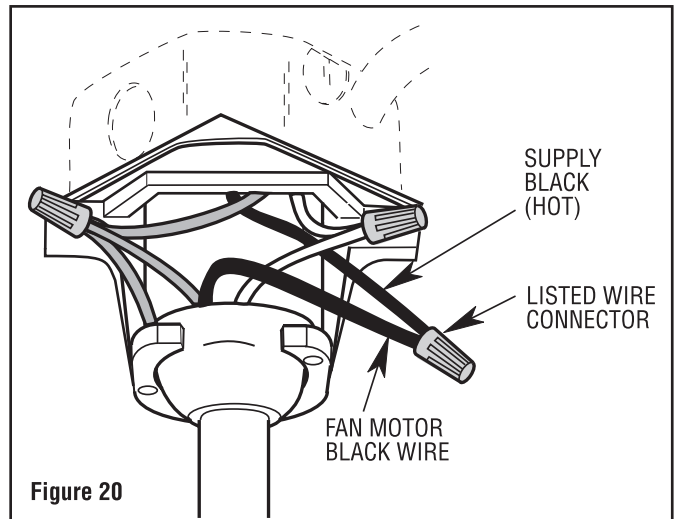

5.4

After connections have been made, turn Wires upward and carefully push Wires into the Outlet Box, with the White and Green Wires on one side of the Outlet Box and position the Black Wire on the other side of the Outlet Box (Figure 21).

⚠ WARNING

Check to see that all connections are tight, including ground, and that no bare wire is visible at the wire connectors, except for the ground wire. Do not operate fan until blades are in place. Noise and fan damage could result.

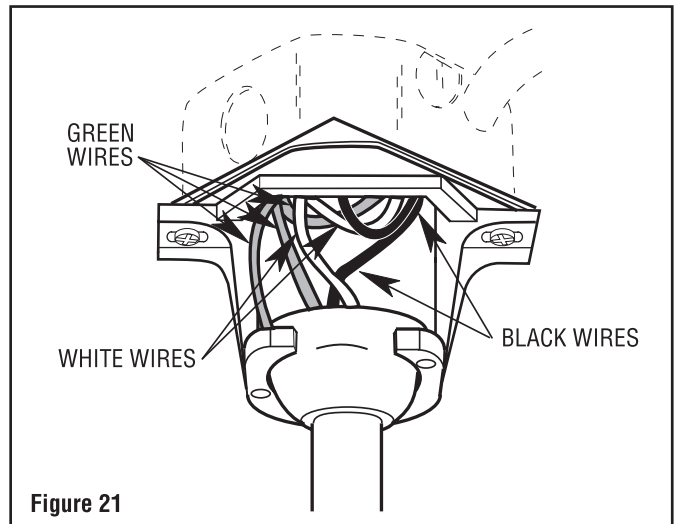

6. Final Assembly

6.1

Screw the Two Threaded Studs (supplied) into the Tapped Holes in the Hanger Bracket (Figure 22).

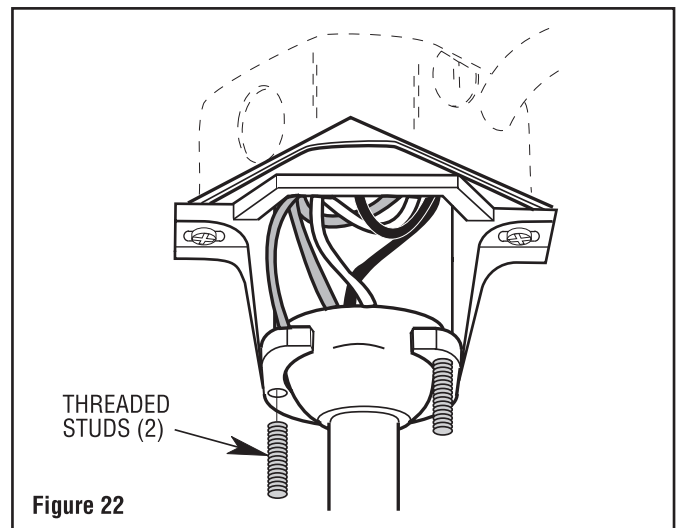

6.2

Lift the Ceiling Cover up to the Threaded Studs and turn until Studs protrude through the Holes in the Ceiling Cover (Figure 23).

Secure the Ceiling Cover in place by sliding Lockwashers over the Threaded Studs and installing the Two Knurled Knobs (supplied) . (Figure 23).

Tighten the Knurled Knobs securely until the Ceiling Cover fits snugly against the Ceiling and the Hole in the Ceiling Cover is clear of the Downrod.

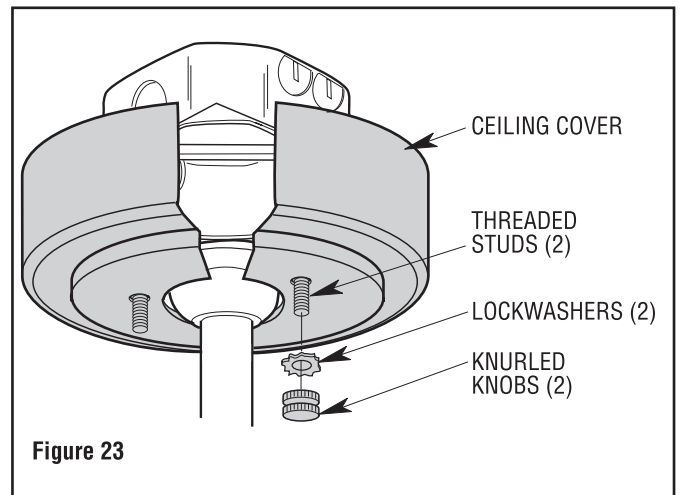

⚠ WARNING

To avoid possible fire or shock, make sure that the electrical wires are completely inside the outlet box and not pinched between the ceiling cover and the ceiling.

7. Installing the Wall Control

! WARNING

Turning off wall switch is not sufficient. To avoid possible electrical shock, be sure electricity is turned off at the main fuse box before wiring. All wiring must be in accordance with National and Local codes and the ceiling fan must be properly grounded as a precaution against possible electrical shock.

7.1

This Control is designed to operate Only ONE Ceiling Fan.

NOTE: Electric connections should be in accordance with the National Electrical Codes and all Local Codes. Before starting, disconnect power to the circuit at the fuse box or circuit breaker panel.

Remove the Faceplate and Screws from the Existing Wall Switch. Pull Switch out from Wall Box.

Determine the "HOT" Wire and the "LOAD" Wire and disconnect these Wires from the Control (Figure 24).

NOTE: Do not attempt to disconnect any Wires not already connected to Existing Switch.

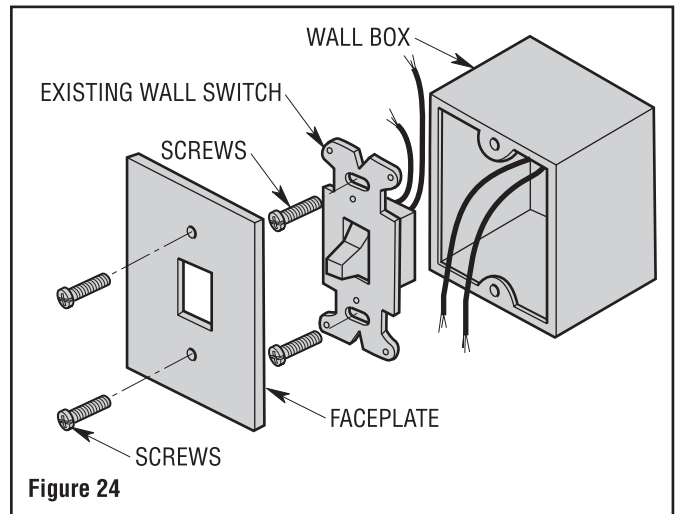

Figure 24

7.2

NOTE: Make all wiring connections using wire connectors (supplied). Make sure that all connections are tight, including ground, and that no bare wire is visible at the wire connectors, except for the ground wire.

NOTE: Set the Fan Control to the OFF position.

! WARNING

Do not connect any neutral (white) wire to this control. Incorrect wiring will damage this control.

Connect the Fan Control Black Wire labeled "TO POWER SUPPLY" to the "HOT" 120V AC Supply Source Wire. Securely connect Wires with Wire Connector, supplied (Figure 25).

Connect the Fan Control Black Wire labeled "TO FAN" to the "LOAD" Black Wire in Wall Box. Securely connect Wires with Wire Connector, supplied (Figure 25).

Connect the Fan Control Green Ground Wire to the Supply Ground Conductor (this may be a bare wire or wire with Green Colored insulation). Securely connect Wires with Wire Connector, supplied (Figure 25).

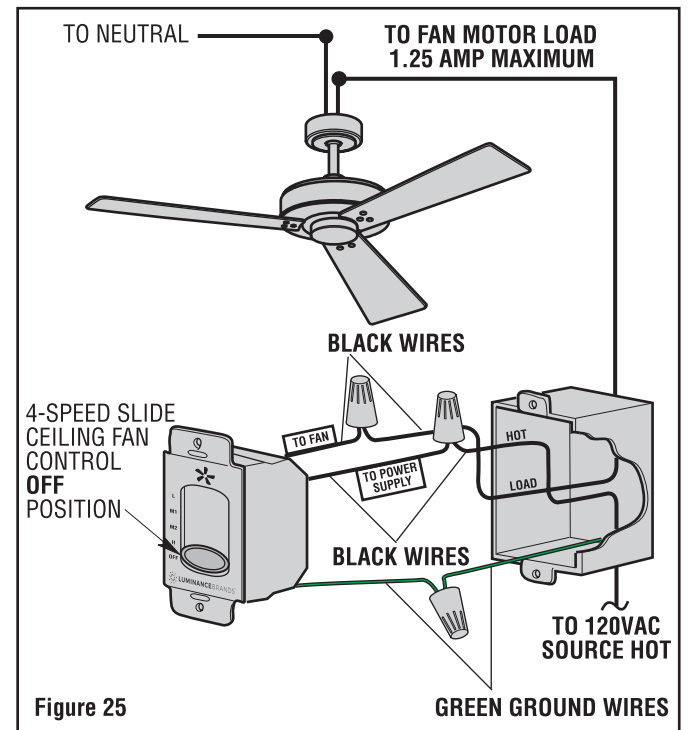

Figure 25

! WARNING

Check to see that all connections are tight and that no bare wires are visible at the wire connectors.

7. Installing the Wall Control (Continued)

7.3

Screw the Fan Control into Wall Box using the supplied 6-32 x 3/4" Screws (Figure 26).

Leave the Fan Control in the "OFF" mode until Fan installation is completed.

Position the Faceplate (supplied) onto the Fan Control. Using the Two supplied 6-32 x 1/4" Screws, Screw the Faceplate to the Wall Box (Figure 26).

Restore Power at the Main Fuse Box or Circuit Breaker Panel.

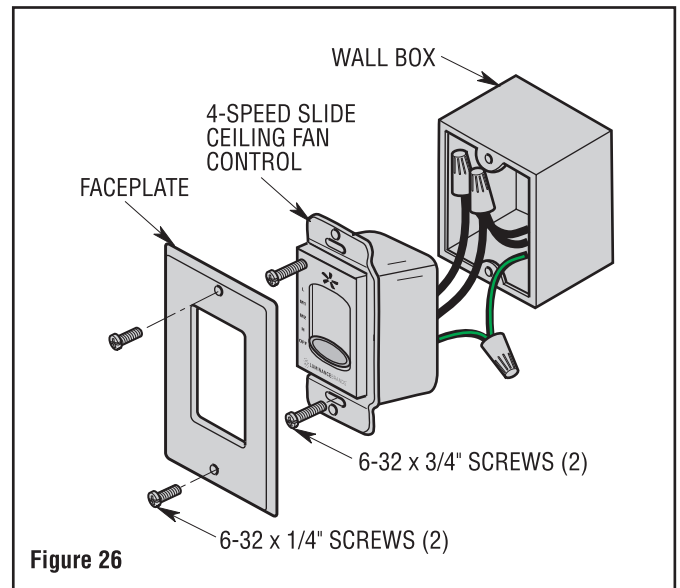

8. Maintenance

IMPORTANT CARE INSTRUCTIONS for your Ceiling Fan

Periodic cleaning of your new Ceiling Fan is the only maintenance that is needed.

When cleaning, use only a soft brush or lint free cloth to avoid scratching the finish.

Abrasive cleaning agents are not required and should be avoided to prevent damage to finish.

WARNING

Do not use water when cleaning your ceiling fan. It could damage the motor or the blades and create the possibility of an electrical shock.

9. Using Your Ceiling Fan

⚠ WARNING

Fan installation must be completed, including the installation of the fan blades, before testing the fan control.

10.1

Check the operation of the Ceiling Fan by sliding the Ceiling Fan Speed Knob through the Four positions (Figure 27).

Slide the Ceiling Fan Speed Knob to the desired airflow:

H = High Speed

M2 = Medium High Speed

M1 = Medium Low Speed

L = Low Speed

To Turn the Fan OFF, Slide the Ceiling Fan Speed Knob down to the OFF position (Figure 27).

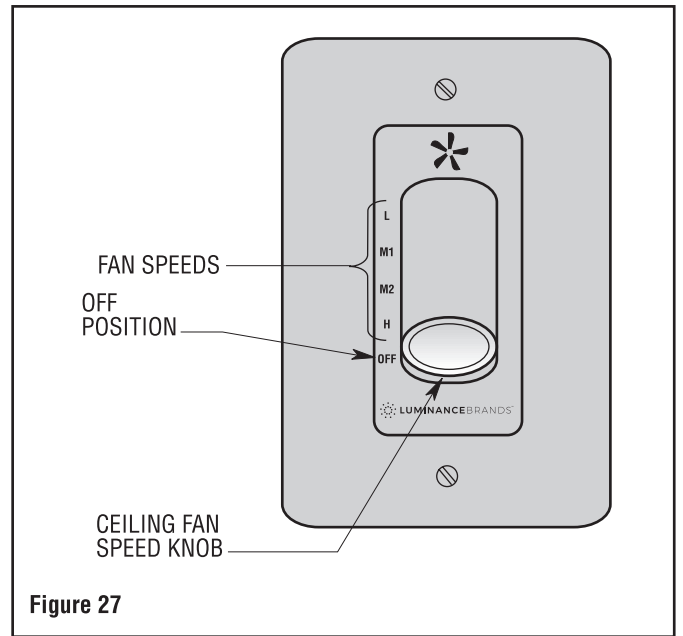

Figure 27

10.2

Restore Electrical Power to the Outlet Box by turning the Electricity on at the Main Fuse Box.

During Summer Months, run the Fan Counter-Clockwise, as you look up at it, to direct airflow downward.

During the Winter Months, run the Fan Clockwise, as you look up at it, to direct airflow upward.

If airflow is desired in the opposite direction, turn the Ceiling Fan OFF and wait for the Blades to stop turning.

Slide the Reverse Switch (located on side of the Center Switch Assembly) to the opposite position, and turn the Ceiling Fan on again (Figure 28).

The Fan Blades will turn in the opposite direction and reverse the airflow.

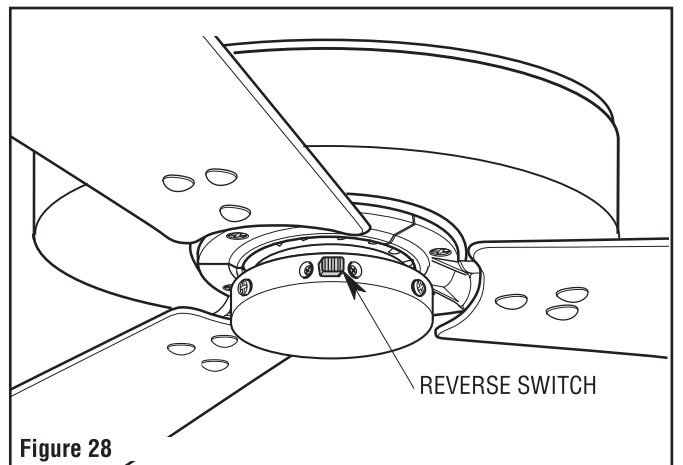

Figure 28

Reverse Switch Information

Season	Blade Rotation Direction
Summer	Counter-Clockwise
Winter	Clockwise

10. Energy Efficient Use of Ceiling Fans

Ceiling Fan performance and energy savings rely heavily on the proper installation and use of the Ceiling Fan. Here are a few tips to ensure quality and product performance.

Choosing the Appropriate Mounting Location.

Ceiling Fans should be installed, or mounted, in the middle of the room and at least 7 feet above the floor and 18 inches from the walls. If ceiling height allows, install the fan 8 - 9 feet above the floor for optimal airflow.

Using the Ceiling Fan Year Round. In the summer, use the Ceiling Fan in the counter-clockwise direction. The airflow produced by the Ceiling Fan creates a wind-chill effect, making you “feel” cooler. Select a fan speed that provides a comfortable breeze, lower speeds consume less energy. In the winter, reverse the motor and operate the ceiling fan at low speed in the clockwise direction. This produces a gentle updraft, which forces warm air near the ceiling down into the occupied space. Remember to adjust your thermostat when using your Ceiling Fan - additional energy and dollar savings could be realized with this simple step!

Turn Off When Not in the Room. Ceiling Fans cool people, not rooms. If the room is unoccupied, turn off the Ceiling Fan to save energy.

11. Troubleshooting

WARNING

FOR YOUR OWN SAFETY TURN OFF POWER AT FUSE BOX OR CIRCUIT BREAKER BEFORE TROUBLESHOOTING YOUR FAN.

TROUBLE	PROBABLE CAUSE	SUGGESTED REMEDY
1. Fan will not start.	1. Fuse or circuit breaker blown.	1. Check main and branch circuit fuses or circuit breakers.
	2. Reverse switch in neutral position.	<div style="border: 1px solid black; padding: 5px; text-align: center;">  WARNING Make sure main power is turned OFF. </div> 2. Make sure reverse switch position is all the way to one side.
2. Fan sounds noisy.	1. Blades not attached to fan. 2. Loose screws in motor housing. 3. Screws securing flanges to motor hub are loose. 4. Screws holding blades to flanges are loose.	1. Attach blades to fan before operating. 2. Check to make sure all screws in motor housing are snug (not over-tight). 3. Check to make sure the screws which attach the flanges to the motor hub are tight. 4. Tighten screws securely.
3. Fan wobbles excessively.	1. Set screw in motor coupler is loose. 2. Set screw in hanger ball/downrod assembly is loose. 3. Screws securing flanges to motor are loose. 4. Flanges not seated properly. 5. Hanger bracket and/or ceiling outlet box is not securely fastened. 6. Fan blades out of balance.	1. Tighten both set screws securely in the motor coupler. 2. Tighten the set screw in the hanger ball/downrod assembly. 3. Check to be sure screws which attach the flanges to the motor are tight. 4. Check to be sure the flanges seat firmly and uniformly to the surface of the motor. If flanges are seated incorrectly, loosen the flange screws and retighten according to the procedure in the section on “Ceiling Fan Assembly”. 5. Tighten the hanger bracket screws to the outlet box, and/or secure outlet box. 6. Interchanging an adjacent (side-by-side) blade pair can redistribute the weight and result in smoother operation.