

Before you start, here are some helpful advice:

1. We suggest you spend a short time reading through this leaflet and then follow the simple step-by-step instructions.
 2. Owing to the size and weight of the corner sofa, we recommend that it is assembled by two adults, on a carpeted or padded area, in the room that it is intended for. Approximate assembly time: 30 minutes.
 3. Please do not use any tools other than those provided or recommended in these instructions.
 4. Please do not throw away any of the packaging or the instruction until you have checked all the components and hardware and the furniture is fully assembled. Please ensure that the packaging is disposed of in a safe and environmentally friendly way.
 5. Assemble all components loosely until advised to tighten. Depending on use, it may be necessary to tighten the components from time to time, so please save the tools that have been provided.
 6. Please keep all pieces out of reach of children.
-

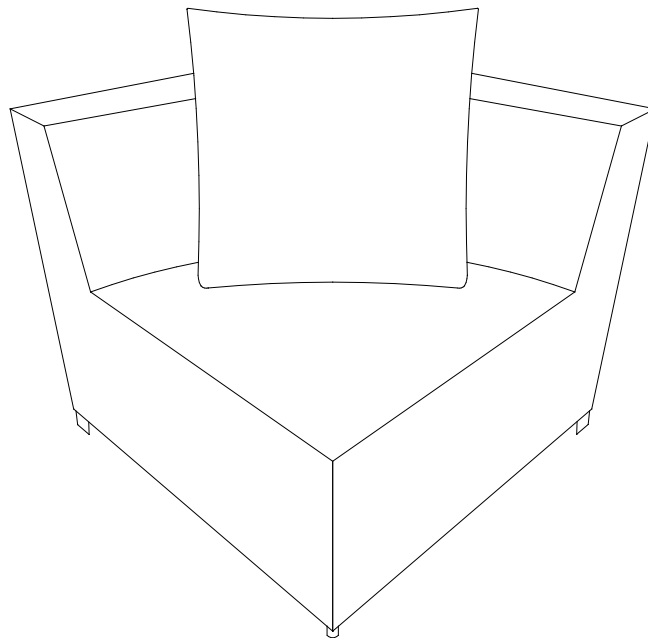

Components:

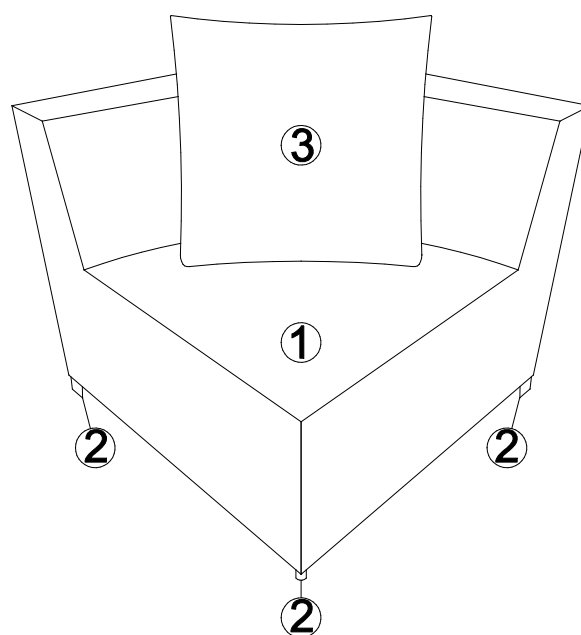

1. Sofa Body x1

2. Sofa Leg x4

3. Pillow x1

STEP 1:

1. Please put **Sofa Body (1)** upside down on a carpeted or padded surface.
2. Tighten 4 pieces of **Sofa Legs (2)** to the bottom of the **Sofa Body (1)** clockwise as shown by hand.

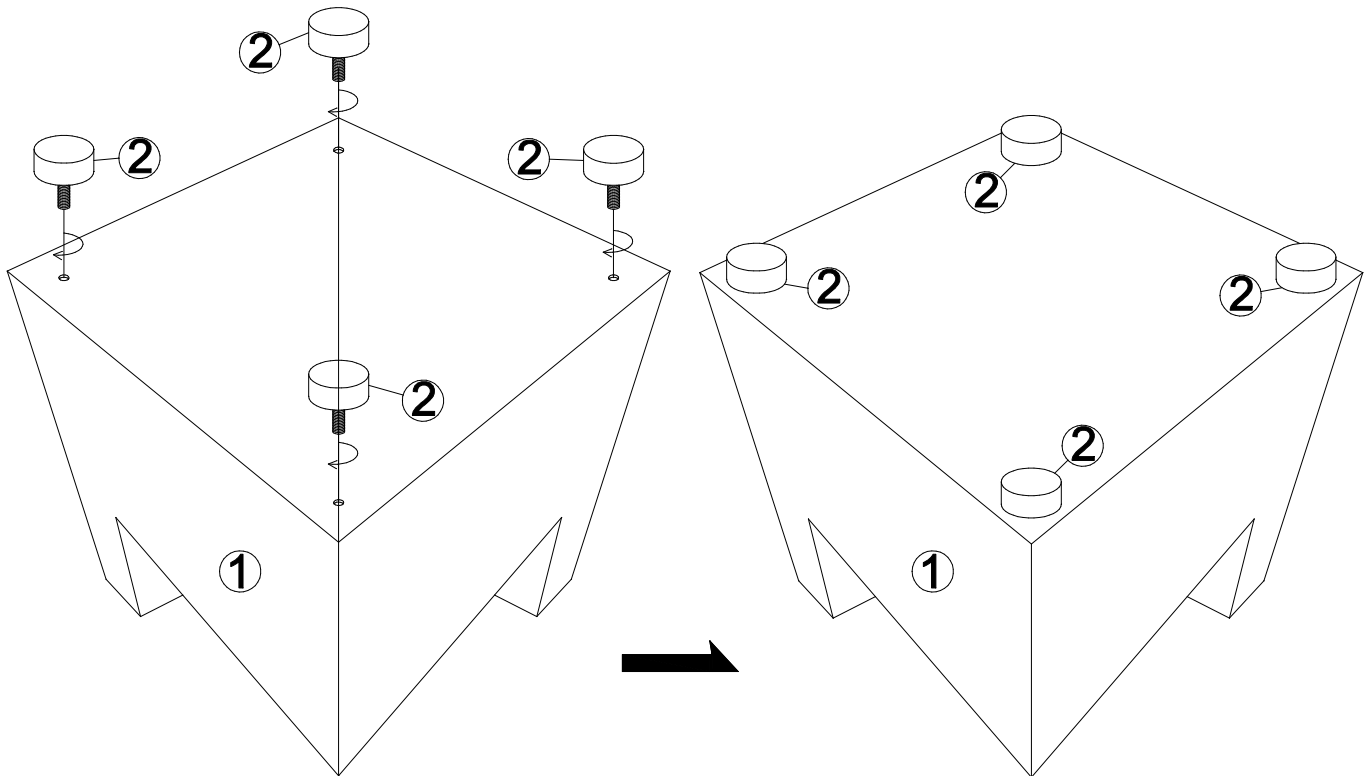

STEP 2:

1. Carefully turn over the assembled **Sofa Body (1)** and **Sofa Legs (2)**.
2. Carefully put 1 piece of **Pillow (3)** to the assembled **Sofa Body (1)** and **Sofa Legs (2)** as shown.

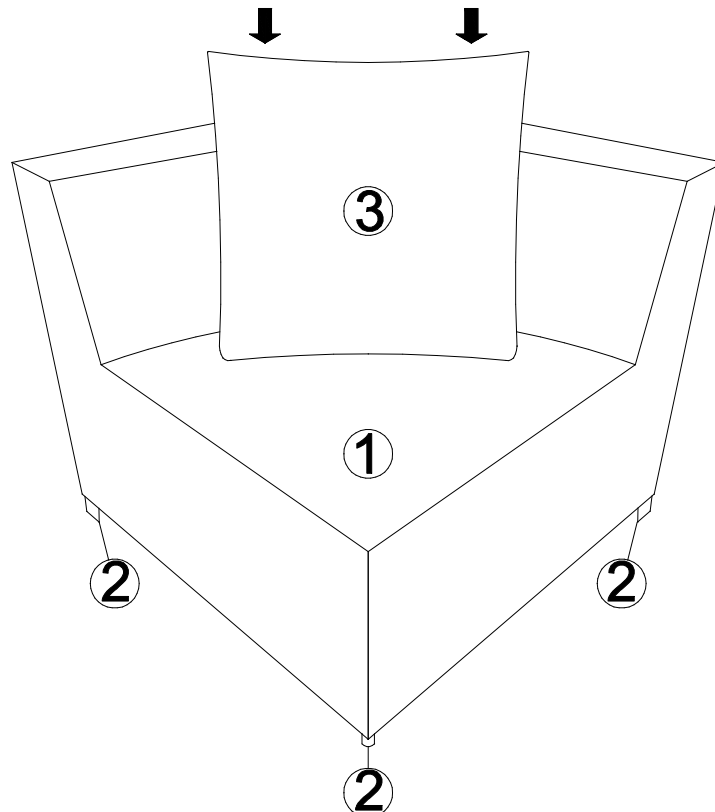

Assembly is complete. Your corner sofa is ready to enjoy now!