

Installation & Assembly

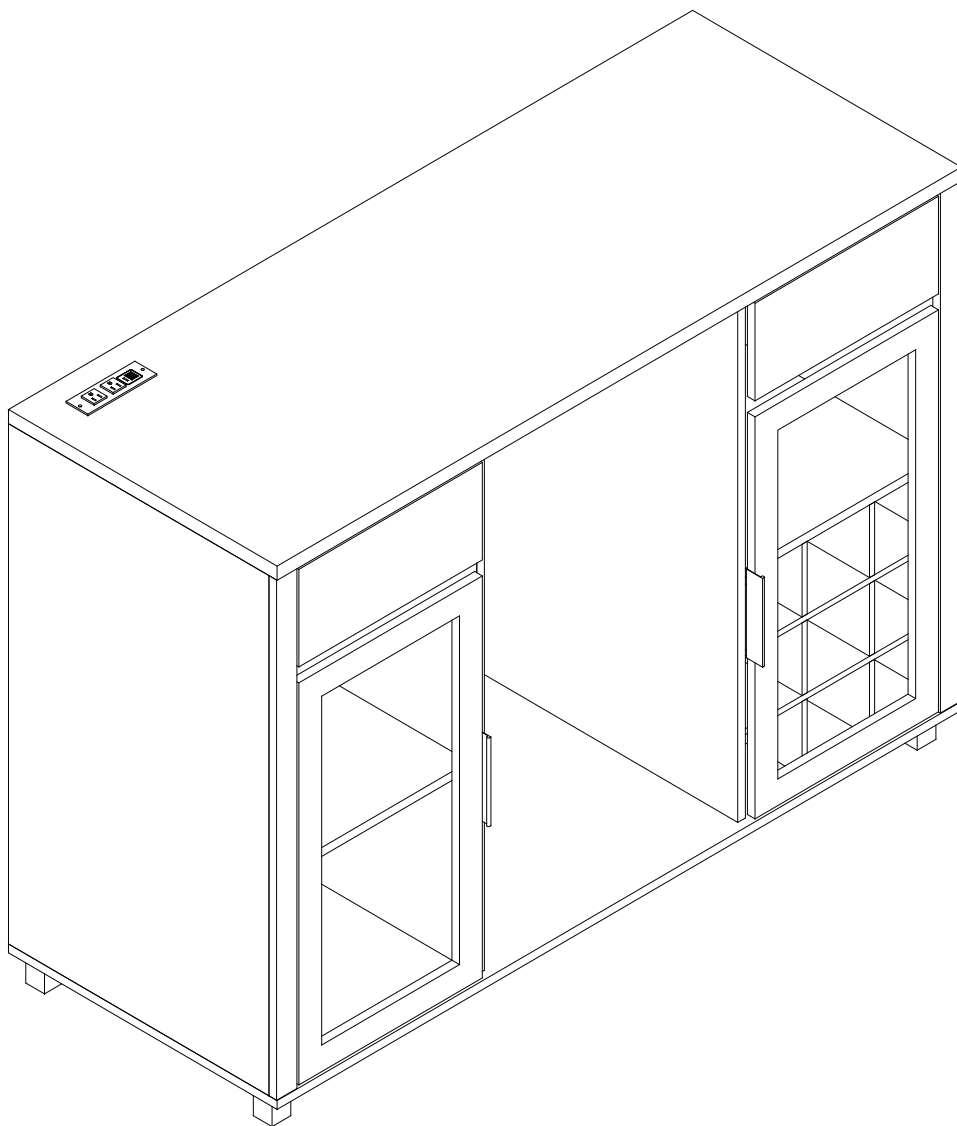

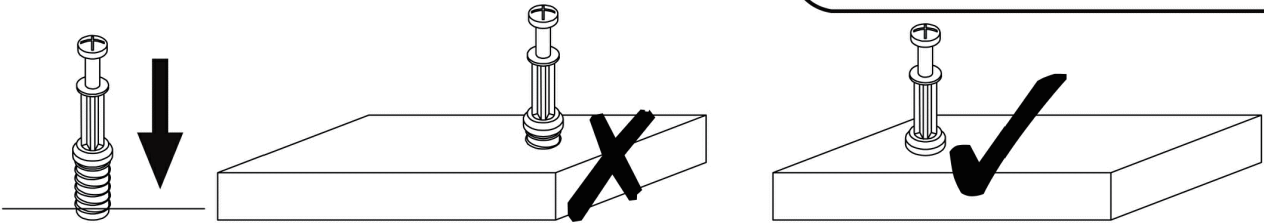

EN_QUICKFIT: Tighten quickfit until shoulder is flush with panel. Do not overtighten or undertighten.

FR_RACCORD RAPIDE: Faites serrer le raccord rapide jusqu'à ce que l'épaulement soit parfaitement encastré dans le panneau. Il ne faut ni trop serrer ni insuffisamment serrer.

ES_QUICKFIT: Apriete quickfit hasta que el hombro se descargue con el panel. NO lo sobreapriete ni lo apriete poco.

DE_QUICKFIT: Ziehen Sie den Quickfit fest, bis die Schulter mit der Platte bündig ist. Bitte nicht zu fest oder zu schwach anziehen.

IT_MONTAGGIO RAPIDO: Stringere il montaggio rapido fino a quando la spalla è a filo con il pannello, non stringere troppo o troppo poco.

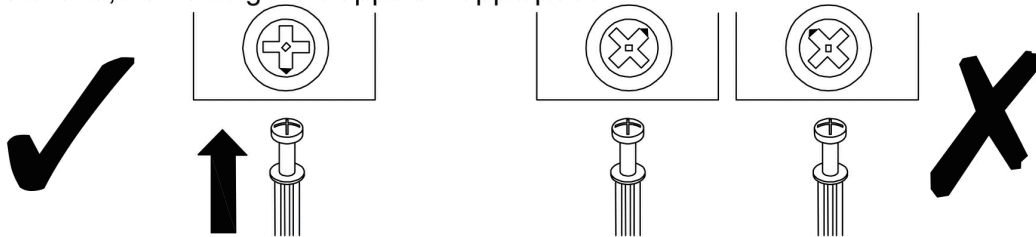

EN_CAM LOCK: When fitting cam lock, ensure starting position is correct before you insert connecting quickfit.

FR_SERRURE BATTEUSE: Avant d'insérer la serrure batteuse, veillez à la bonne orientation avant d'insérer le raccord rapide.

ES_CIERRE DE LA CÁMARA: Cuando instale el cierre de la cámara, asegúrese de que la posición de inicio es correcta antes de que inserte el quickfit conector.

DE_CAM-LOCK: Achten Sie bei der Montage des Cam-Locks auf die richtige Ausgangsposition, bevor Sie den Quickfit einsetzen.

IT_BLOCCAGGIO A CAMMA: Quando si monta il bloccaggio a camma, assicurarsi che la posizione iniziale sia corretta prima di inserire il montaggio rapido di collegamento.

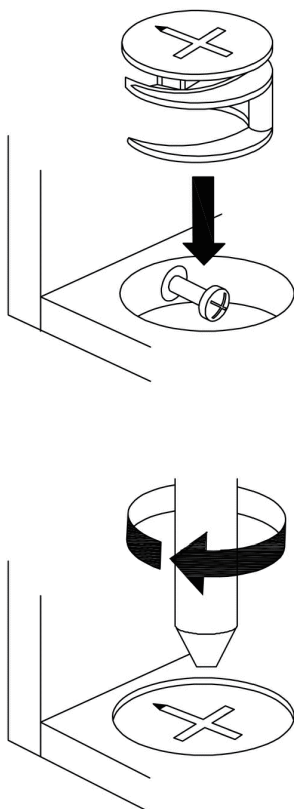

EN_Quickfit head should be in the centre of the cam lock when the two panels are joined.

Cam lock should be inserted before quickfit.

FR_Lorsque les deux panneaux sont assemblés, la tête du raccord rapide doit reposer au centre de la serrure batteuse. Il faut insérer la serrure batteuse avant le raccord rapide.

ES_El cabezal del quickfit debe estar en el centro del cierre de la cámara cuando se unan los dos paneles.

Se debe insertar el cierre de la cámara antes que el quickfit.

DE_Der Quickfit-Kopf sollte sich in der Mitte des Cam-Locks befinden, wenn die beiden Platten zusammengefügt sind.

Der Cam-Lock sollte vor dem Quickfit eingesetzt werden.

IT_La testa del montaggio rapido deve trovarsi al centro del bloccaggio a camma quando i due pannelli sono uniti.

Il Bloccaggio a Camma deve essere inserito prima del montaggio rapido.

EN_Turn cam lock clockwise to tighten.

FR_Faites tourner la serrure batteuse dans le sens des aiguilles d'une montre pour la resserrer.

ES_Gire el cierre de la cámara en sentido horario para apretarlo.

DE_Drehen Sie den Cam-Lock im Uhrzeigersinn, um ihn festzuziehen.

IT_Ruotare il bloccaggio a camma in senso orario per stringere.



DE

1. Die maximale Tragfähigkeit der Oberplatte beträgt 60 kg, bitte nicht überladen.
2. Lassen Sie Kinder nicht auf Möbeln klettern, da dies zu Umstürzen und schweren Verletzungen führen kann.
3. Um die Sicherheit zu gewährleisten, installieren Sie bitte gemäß der Anleitung und ziehen Sie bei Bedarf Fachleute hinzu.
4. Stellen Sie Möbel nicht in die Nähe von Feuerquellen oder heißen Gegenständen, um Brandgefahr zu vermeiden.
5. Stellen Sie Möbel nicht in feuchten Umgebungen auf, um Materialschäden zu verhindern.
6. Überprüfen Sie regelmäßig alle Verbindungs- und Befestigungselemente, um sicherzustellen, dass sie fest sitzen und Unfälle zu vermeiden.
7. Dieses Produkt ist mit einem Kipp-Schutz ausgestattet, installieren Sie diesen Schutz, um Verletzungen durch Umstürzen zu vermeiden.

UK

1. The maximum weight capacity of the top panel is 60kg; please do not overload.
2. Do not allow children to climb on furniture, as this may cause tipping and serious injury.
3. To ensure safety, please install correctly according to the instructions and seek professional assistance if necessary.
4. Do not place furniture near fire sources or hot objects to avoid fire hazards.
5. Do not place furniture in damp environments to prevent material damage.
6. Regularly check all connectors and fasteners to ensure they are secure to prevent accidents.
7. This product comes with an anti-tipping device; install this device to prevent injuries from tipping.

FR

1. La charge maximale du panneau supérieur est de 60 kg, ne pas surcharger.
2. Ne laissez pas les enfants grimper sur les meubles, cela peut entraîner des basculements et des blessures graves.
3. Pour garantir la sécurité, installez correctement selon les instructions et demandez l'aide de professionnels si nécessaire.
4. Ne placez pas les meubles près de sources de chaleur ou d'objets chauds pour éviter les risques d'incendie.
5. Ne placez pas les meubles dans des environnements humides pour éviter d'endommager les matériaux.
6. Vérifiez régulièrement tous les connecteurs et les fixations pour vous assurer qu'ils sont bien serrés et éviter les accidents.
7. Ce produit est équipé d'un dispositif anti-basculement; installez ce dispositif pour éviter les blessures dues au basculement.

IT

1. La capacità massima del pannello superiore è di 60 kg; non sovraccaricare.
2. Non permettere ai bambini di arrampicarsi sui mobili, poiché ciò può causare ribaltamenti e gravi infortuni.
3. Per garantire la sicurezza, installare correttamente secondo le istruzioni e, se necessario, chiedere assistenza a professionisti.
4. Non posizionare i mobili vicino a fonti di calore o oggetti caldi per evitare rischi di incendio.
5. Non posizionare i mobili in ambienti umidi per prevenire danni ai materiali.
6. Controllare regolarmente tutti i connettori e le viti per assicurarsi che siano saldi e prevenire incidenti.
7. Questo prodotto è dotato di un dispositivo anti-ribaltamento; installare questo dispositivo per evitare infortuni da ribaltamento.

ES

1. La capacidad máxima del panel superior es de 60 kg; no sobrecargar.
2. No permita que los niños escalen los muebles, ya que esto puede causar volcaduras y lesiones graves.
3. Para garantizar la seguridad, instale correctamente según las instrucciones y busque ayuda profesional si es necesario.
4. No coloque los muebles cerca de fuentes de fuego u objetos calientes para evitar riesgos de incendio.
5. No coloque los muebles en ambientes húmedos para evitar daños en los materiales.
6. Revise regularmente todos los conectores y sujetadores para asegurarse de que estén seguros y prevenir accidentes.
7. Este producto viene con un dispositivo anti-vuelco; instale este dispositivo para prevenir lesiones por vuelcos.

NL

1. De maximale draagcapaciteit van het bovenpaneel is 60 kg; niet overbelasten.
2. Laat kinderen niet op meubels klimmen, dit kan leiden tot omvallen en ernstige verwondingen.
3. Installeer correct volgens de instructies om de veiligheid te waarborgen, en schakel indien nodig professionele hulp in.
4. Plaats meubels niet in de buurt van vuurbronnen of warme objecten om brandgevaar te voorkomen.
5. Plaats meubels niet in vochtige omgevingen om materiaalschade te voorkomen.
6. Controleer regelmatig alle verbindingen en bevestigingsmiddelen om ervoor te zorgen dat ze stevig zijn en om ongevallen te voorkomen.
7. Dit product is uitgerust met een kantelbeveiliging; installeer dit apparaat om verwondingen door omvallen te voorkomen.

SE

1. Den maximala viktkapaciteten för överpanelen är 60 kg; överbelasta inte.
2. Låt inte barn klättra på möbler, då detta kan orsaka tippning och allvarliga skador.
3. För att säkerställa säkerheten, installera korrekt enligt instruktionerna och sök professionell hjälp om det behövs.
4. Placera inte möbler nära eldkällor eller heta föremål för att undvika brandrisk.
5. Placera inte möbler i fuktiga miljöer för att förhindra skador på materialen.
6. Kontrollera regelbundet alla kopplingar och fästelement för att säkerställa att de är säkra för att förhindra olyckor.
7. Denna produkt levereras med en anti-tippanordning; installera denna anordning för att förhindra skador vid tippning.

PL

1. Maksymalne obciążenie górnej płyty wynosi 60 kg; nie przeciążaj.
2. Nie pozwól dzieciom wspiąć się na meble, ponieważ może to prowadzić do przewrócenia się i poważnych obrażeń.
3. Aby zapewnić bezpieczeństwo, zainstaluj prawidłowo zgodnie z instrukcją i w razie potrzeby skorzystaj z pomocy profesjonalistów.
4. Nie stawiaj mebli w pobliżu źródeł ognia lub gorących przedmiotów, aby uniknąć ryzyka pożaru.
5. Nie stawiaj mebli w wilgotnych środowiskach, aby zapobiec uszkodzeniu materiałów.
6. Regularnie sprawdzaj wszystkie złącza i elementy mocujące, aby upewnić się, że są stabilne i aby zapobiec wypadkom.
7. Produkt ten jest wyposażony w urządzenie zapobiegające przewróceniu; zainstaluj to urządzenie, aby uniknąć obrażeń w wyniku przewrócenia.

DE: Wenn Sie die Lichter nicht erfolgreich arbeiten lassen können, überprüfen Sie bitte die Folgendes:

1. Bitte überprüfen Sie die Fernbedienung. Sie müssen die Fernbedienung abreißen Plastikseptum vor Gebrauch.
2. Lassen Sie die Fernbedienung nicht zu weit vom Empfänger entfernt sein. Es gibt kein Hindernis zwischen ihnen.
3. Bitte beachten Sie, dass die Fernbedienung für den Transport keine Batterien enthält. Das Batteriemodell lautet:

FR: Si vous ne parvenez pas à faire fonctionner les lumières correctement, veuillez vérifier les points suivants?:

1. Veuillez vérifier la télécommande. Vous devez retirer le septum en plastique de la télécommande avant utilisation.
2. Ne laissez pas la télécommande être trop éloignée du récepteur. Il n'y a aucun obstacle entre eux.
3. Veuillez noter que la télécommande ne contient pas de piles pour le transport. Le modèle de batterie est?:

UK: If you can't make the lights work successfully, please check the following:

1. Please check the remote control. You need to tear off the remote plastic septum before use.
2. Don't let the remote control be too far from the receiver. There is no obstacle between them.
3. Please note that the remote control does not contain batteries for transportation. The battery model is:

IT: Se non riesci a far funzionare le luci correttamente, ti preghiamo di controllare quanto segue:

1. Controlla il telecomando. Devi rimuovere il foglio di plastica protettivo dal telecomando prima dell'uso.
2. Non allontanare il telecomando troppo dal ricevitore. Assicurati che non ci siano ostacoli tra di essi.
3. Si prega di notare che il telecomando non contiene batterie per il trasporto. Il modello di batteria è:

ES: Si no puedes hacer funcionar las luces correctamente, por favor, revisa lo siguiente:

1. Verifica el control remoto. Debes quitar la película plástica protectora del control remoto antes de usarlo.
2. No alejes el control remoto demasiado del receptor. Asegúrate de que no haya obstáculos entre ellos.
3. Ten en cuenta que el control remoto no contiene baterías para el transporte. El modelo de la batería es:

NL: Als u de lichten niet succesvol kunt laten werken, controleer dan het volgende:

1. Controleer de afstandsbediening. U moet de plastic beschermfolie van de afstandsbediening verwijderen voordat u deze gebruikt.
2. Laat de afstandsbediening niet te ver van de ontvanger afstaan. Er mogen geen obstakels tussen hen in staan.
3. Houd er rekening mee dat de afstandsbediening geen batterijen bevat voor transport. Het batterijmodel is:

SE: Om du inte kan få lamporna att fungera korrekt, vänligen kontrollera följande:

1. Kontrollera fjärrkontrollen. Du måste ta bort den plastskyddade septum innan du använder den.
2. Låt inte fjärrkontrollen vara för långt från mottagaren. Det får inte finnas några hinder mellan dem.
3. Observera att fjärrkontrollen inte innehåller batterier för transport. Batterimodellen är:

PL: Jeśli nie możesz prawidłowo uruchomić światła, sprawdź poniższe:

1. Sprawdź pilot. Należy zdjąć plastikową osłonę z pilota przed użyciem.
2. Nie trzymaj pilota zbyt daleko od odbiornika. Pomiędzy nimi nie może być przeszkód.
3. Zwróć uwagę, że pilot nie zawiera baterii do transportu. Model baterii to:

·Components - fittings

Please check you have all the panels listed below.

Note: The quantities below are the correct amount to complete the assembly. In some cases more fittings may be supplied than are required.

·Komponenten Verschraubungen

Bitte überprüfen Sie, ob Sie alle unten aufgeführten Panels haben.

Hinweis: Die folgende Menge ist die richtige Menge, um die Montage abzuschließen. In einigen Fällen können mehr Armaturen geliefert werden, als erforderlich.

·Composants - accessoires

Veuillez vérifier que vous possédez tous les panneaux énumérés ci - dessous.

Remarque: les quantités ci - dessous sont les quantités correspondantes nécessaires pour terminer l'assemblage. Dans certains cas, plus d'accessoires que nécessaire peuvent être fournis.

·Componenti - accessori

Controlla di avere tutti i pannelli elencati di seguito.

Nota: i quantitativi indicati di seguito rappresentano il quantitativo corrispondente al completamento del montaggio. In alcuni casi possono essere forniti più accessori di quelli necessari.

·Componentes y accesorios

Por favor compruebe que tiene todos los paneles que se enumeran a continuación.

Nota: las cantidades de abajo son la cantidad de correct para completar el montaje. En algunos casos pueden suministrarse más accesorios de los necesarios.

·Componenten - toebehoren

Controleer of u alle panelen hieronder heeft.

Opmerking: de volgende hoeveelheden zijn de juiste hoeveelheid voor de complete montage. In sommige gevallen kunnen er meer accessoires worden geleverd dan nodig is.

·Komponenter - kopplingar

Kontrollera att du har alla paneler listade nedan.

Notera: Kvantiteten nedan är det korrekta beloppet för att slutföra monteringen. I vissa fall kan fler kopplingar levereras än vad som krävs.



·Komponenty - okucia

Kontrollera att du har alla paneler listade nedan.

Notera: Kvantiteten nedan är det korrekta beloppet för att slutföra monteringen. I vissa fall kan fler kopplingar levereras än vad som krävs.

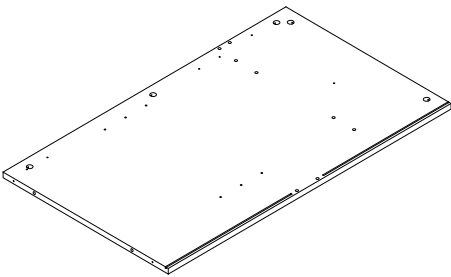
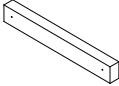
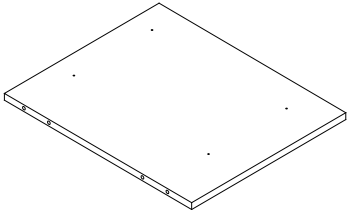
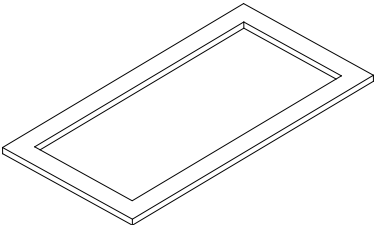
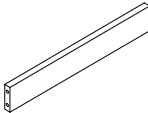
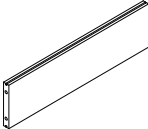
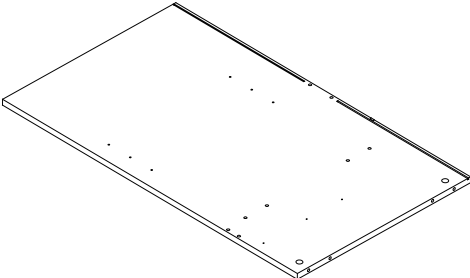
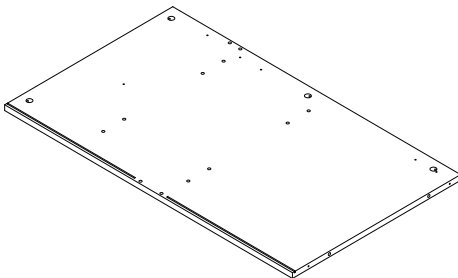
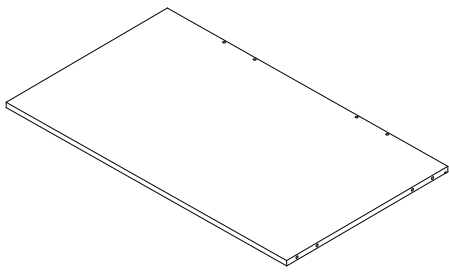
Box:1/1

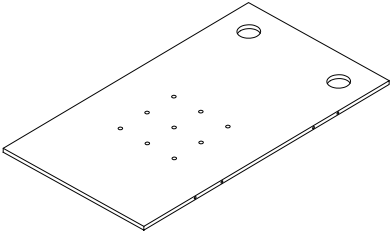
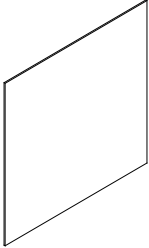
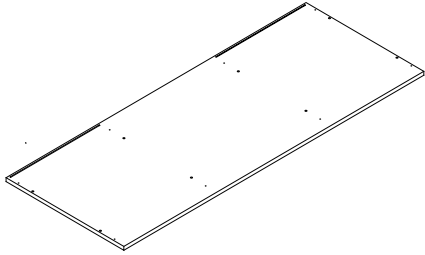
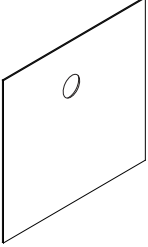
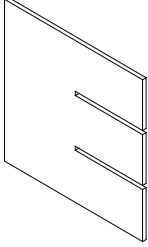
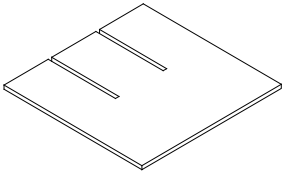
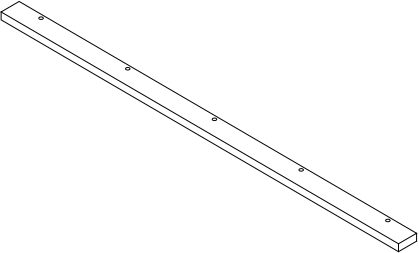
		
① x 1pc	② x 2pcs	③ x 1pc
		
④ x 2pcs	⑤ x 2pcs	⑥ x 2pcs
		
⑦ x 1pc	⑧ x 1pc	⑨ x 1pc

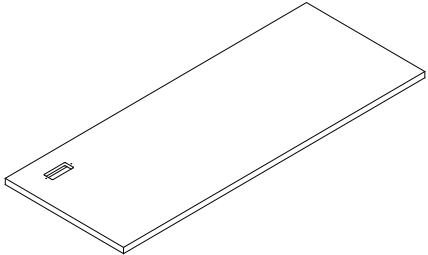
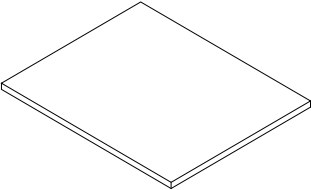
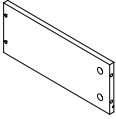
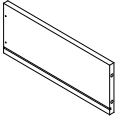
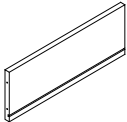
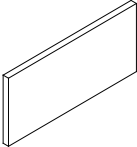
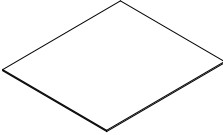
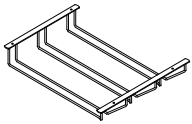
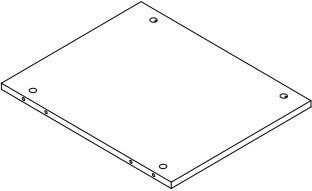
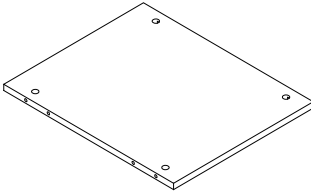
		
⑩x 1pc	⑪x 3pcs	⑫x 1pc
		
⑬x 1pc	⑭x 2pcs	⑮x 2pcs
		
⑯x 2pcs	⑰x 4pcs	⑱x 1pc
		
⑲x 1pc	⑳x 2pcs	㉑x 2pcs
		
㉒x 2pcs	㉓x 2pcs	㉔x 2pcs
		
㉕x 1pc	㉖x 1pc	㉗x 1pc

·Components - fittings

Please check you have all the panels listed below.

Note: The quantitie below are the correcect amount to complete the assembly. In some cases more fittings may be supplied than are required.

·Komponenten Verschraubungen

Bitte überprüfen Sie, ob Sie alle unten aufgeführten Panels haben.

Hinweis: Die folgende Menge ist die richtige Menge, um die Montage abzuschließen. In einigen Fällen können mehr Armaturen geliefert werden, als erforderlich.

·Composants - accessoires

Veuillez vérifier que vous possédez tous les panneaux énumérés ci - dessous.

Remarque: les quantités ci - dessous sont les quantités correspondantes nécessaires pour terminer l'assemblage. Dans certains cas, plus d'accessoires que nécessaire peuvent être fournis.

·Componenti - accessori

Controlla di avere tutti i pannelli elencati di seguito.

Nota: i quantitativi indicati di seguito rappresentano il quantitativo corrispondente al completamento del montaggio. In alcuni casi possono essere forniti più accessori di quelli necessari.

·Componentes y accesorios

Por favor compruebe que tiene todos los paneles que se enumeran a continuación.

Nota: las cantidades de abajo son la cantidad de correcect para completar el montaje. En algunos casos pueden suministrarse más accesorios de los necesarios.

·Componenten - toebehoren

Controleer of u alle panelen hieronder heeft.

Opmerking: de volgende hoeveelheden zijn de juiste hoeveelheid voor de complete montage. In sommige gevallen kunnen er meer accessoires worden geleverd dan nodig is.

·Komponenter - kopplingar











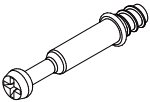
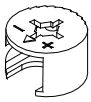

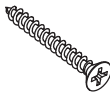

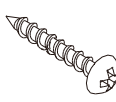
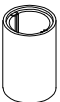
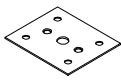
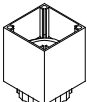
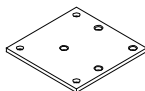

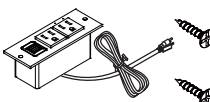

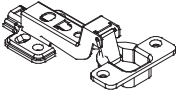
Kontrollera att du har alla paneler listade nedan.

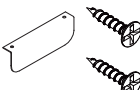
Notera: Kvantiteten nedan är det korrekta beloppet för att slutföra monteringen. I vissa fall kan fler kopplingar levereras än vad som krävs.

·Komponenty - okucia

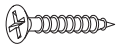
Kontrollera att du har alla paneler listade nedan.

Notera: Kvantiteten nedan är det korrekta beloppet för att slutföra monteringen. I vissa fall kan fler kopplingar levereras än vad som krävs.

		 Φ6x30mm	 M4x40mm	 M3.5x12mm	 M4x35mm
A x 50+2pcs	B x 50+2pcs	C x 40+2pcs	D x 18pcs	E x 28pcs	F x 12+1pcs
				 M4x14mm	
G x 2pcs	H x 2pcs	I x 4pcs	J x 4pcs	K x 20pcs	L x 1pc
		 M4x14mm			
M x 4pcs	N x 4pcs	O x 24pcs	P x 2pcs	Q x 16pcs	R x 2pcs
	 M3.5x16mm				
S x 2pcs	T x 20pcs	CL x 2	CR x 2	DL x 2	DR x 2

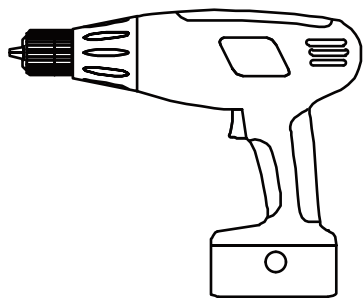

**IT IS RECOMMENDED
TO USE POWER TOOLS**

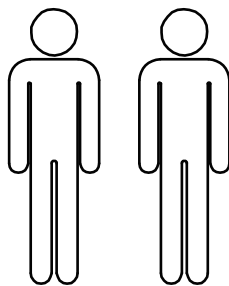

**ITWO PEOPLE
INSTALL TOGETHER**

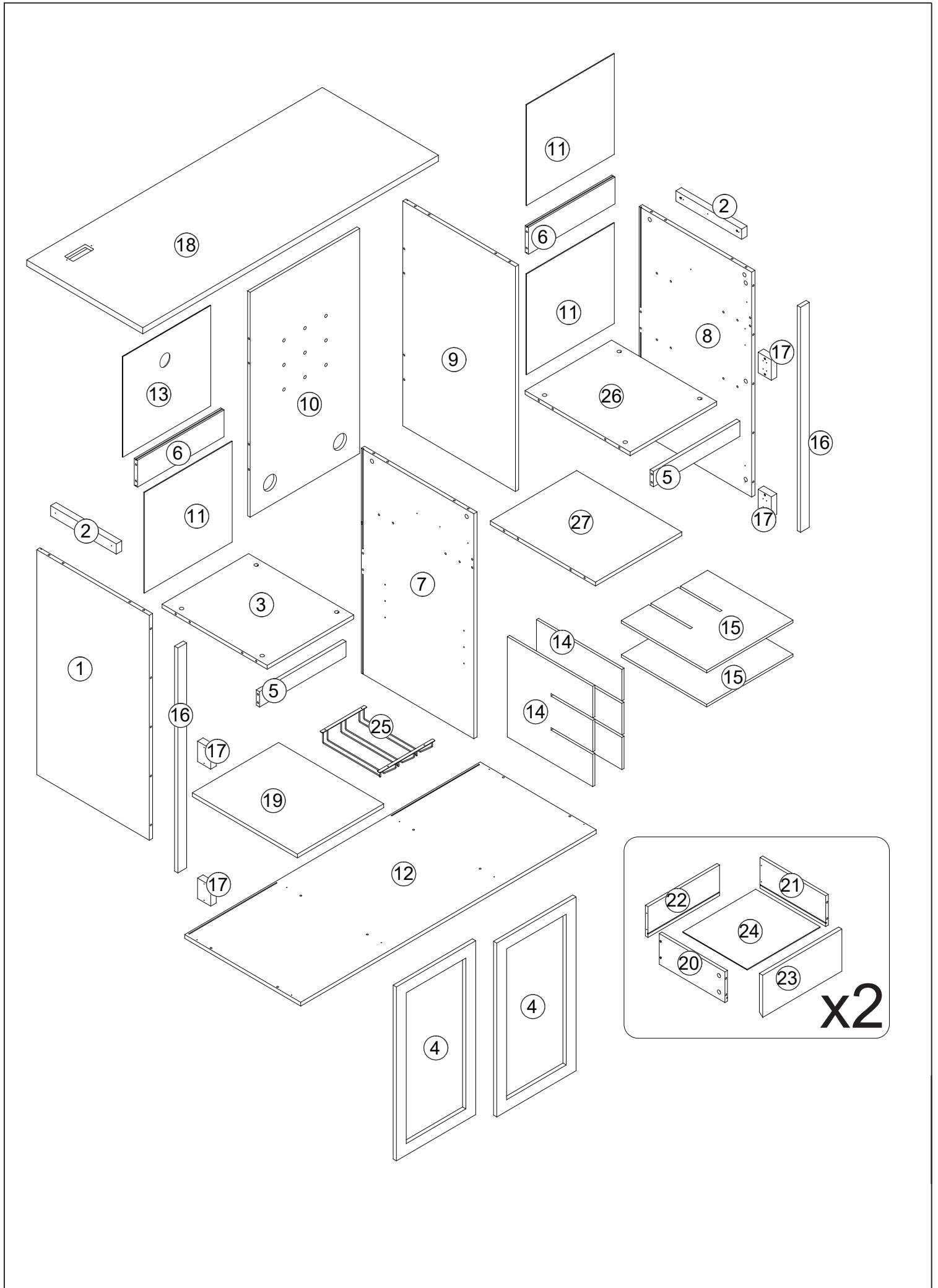

Step 1

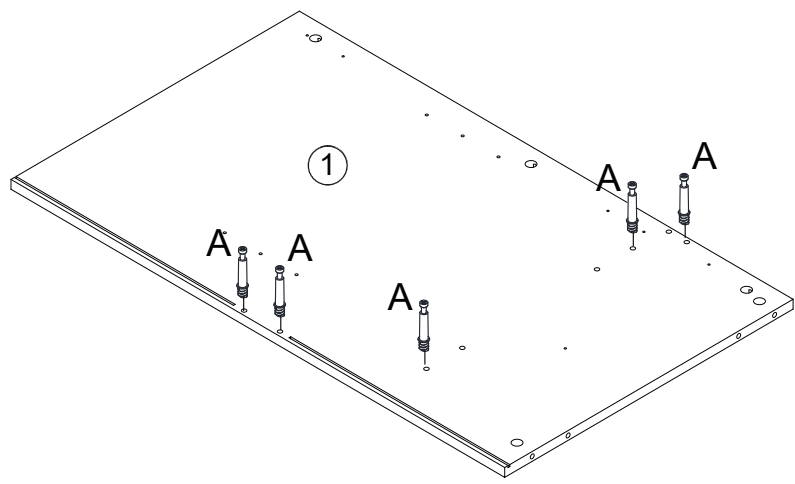

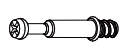

A x 5pcs

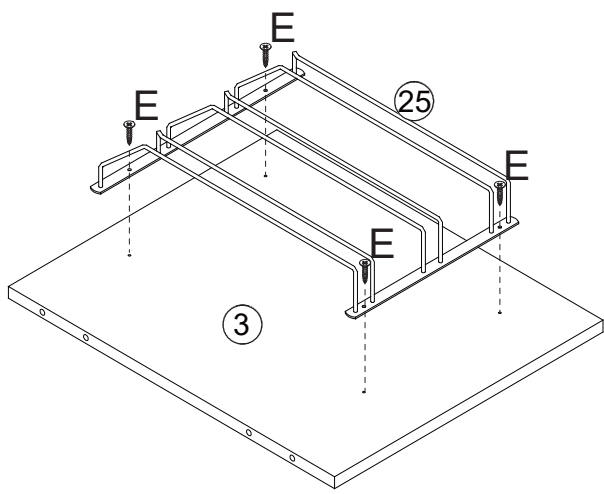

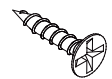
Step 2



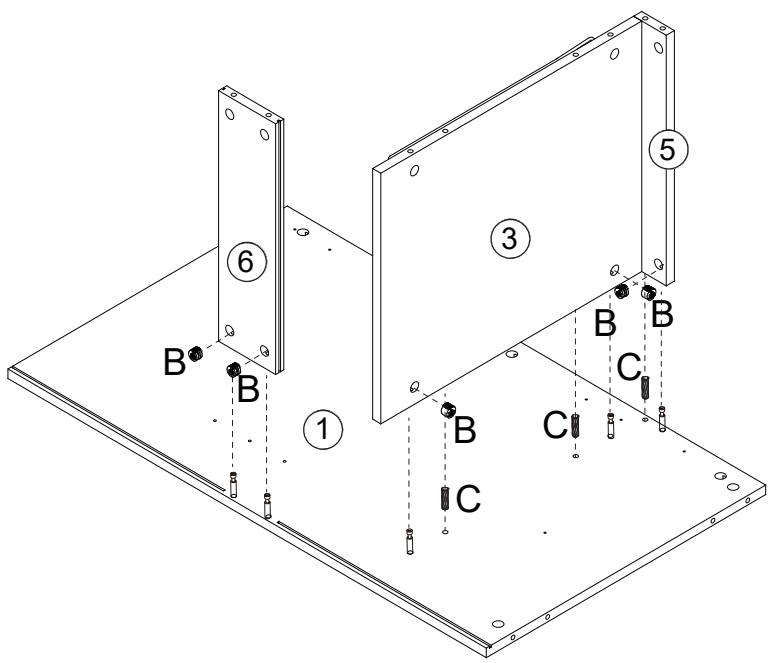

E x 4pcs

Step 3

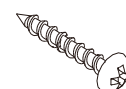
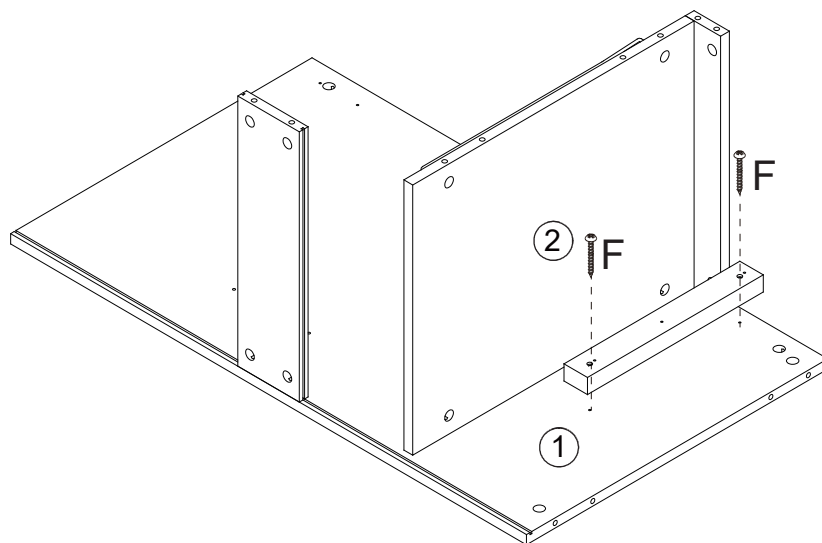

	
C x 3pcs	B x 5pcs

Step 4



F x 2pcs

Step 5

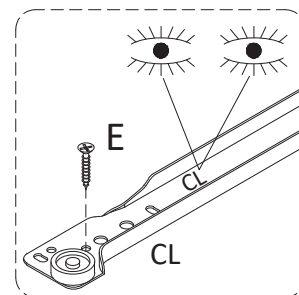
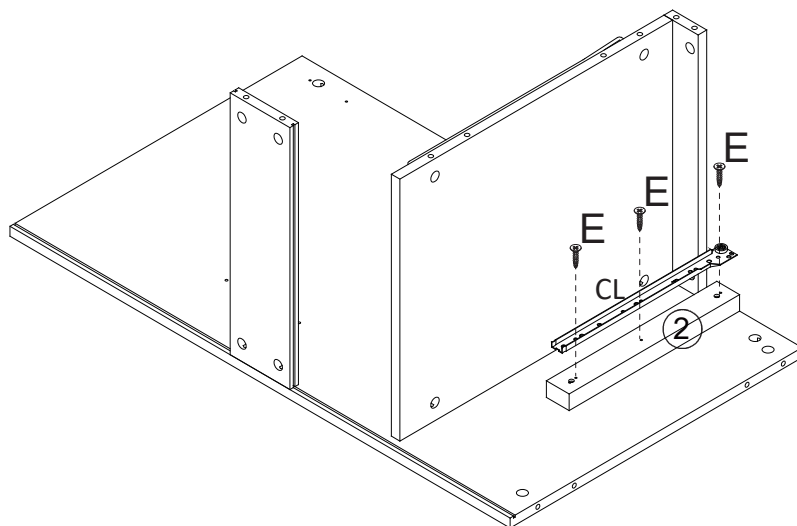

CL x 1pc

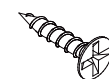

E x 3pcs

Step 6

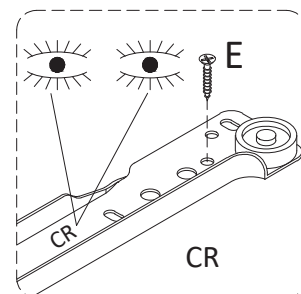
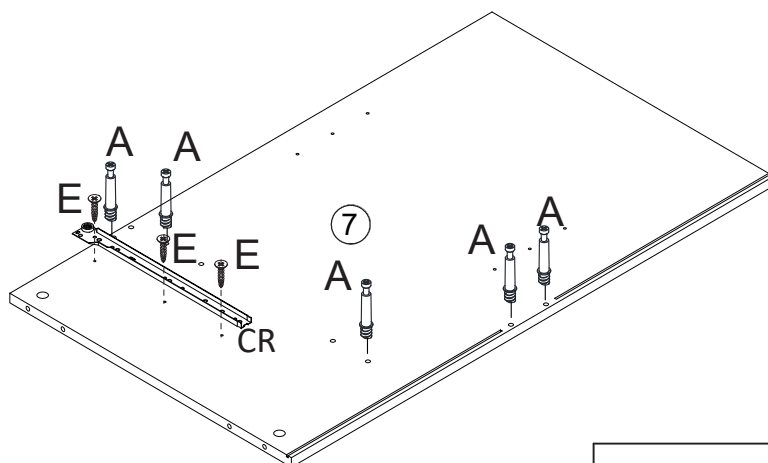

CR x 1pc





E x 3pcs

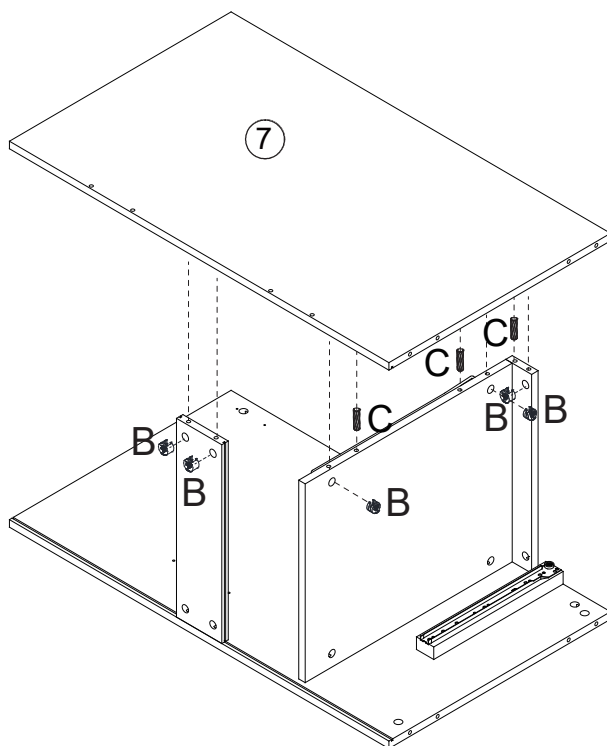

A x 5pcs

Step 7



	
C x 3pcs	B x 5pcs

Step 8

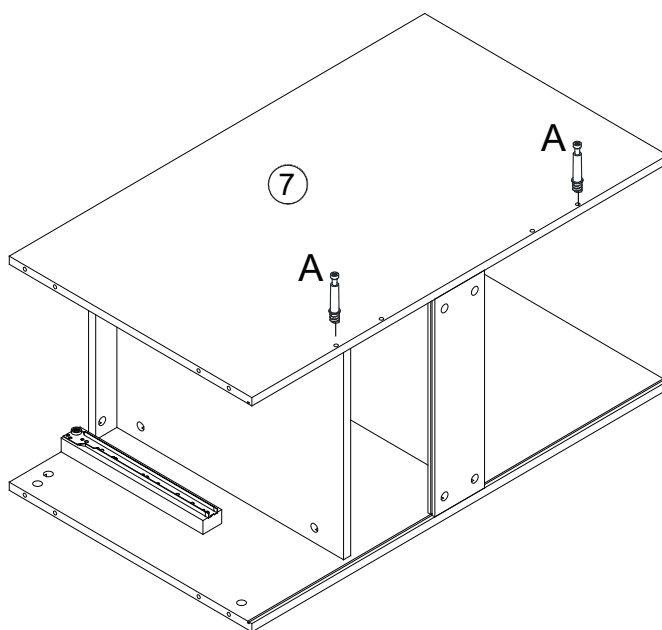

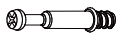

A x 2pcs

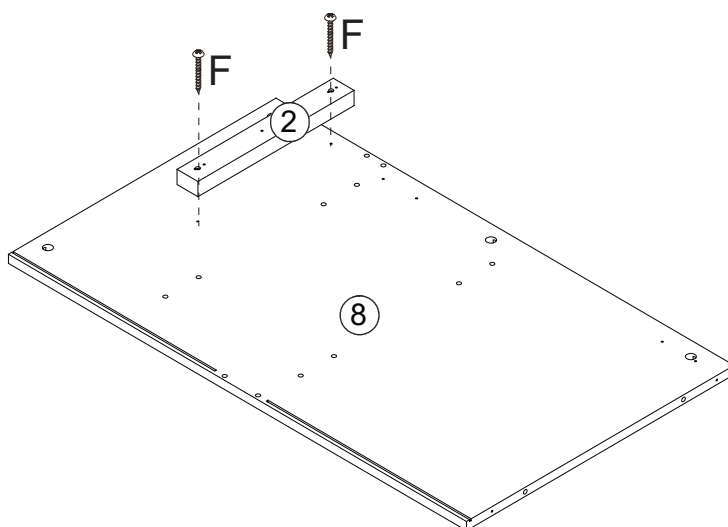

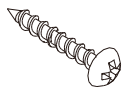
Step 9



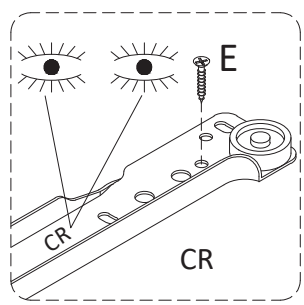
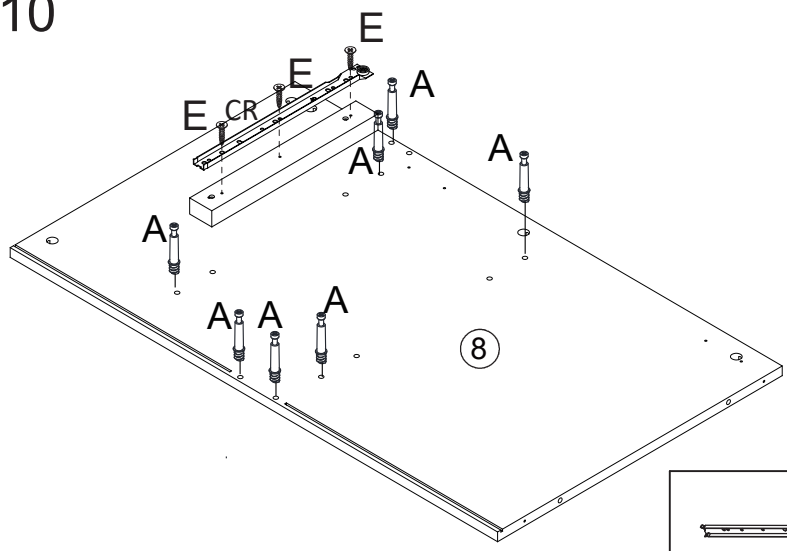

F x 2pcs



Step 10

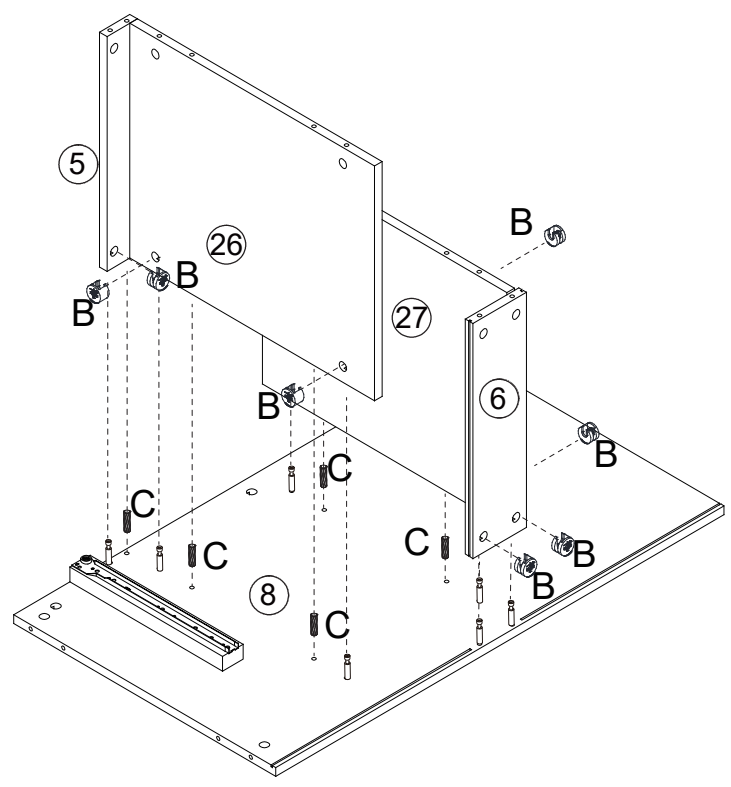

		
CR x 1pc	E x 3pcs	A x 7pcs



Step 11



	
C x 5pcs	B x 7pcs

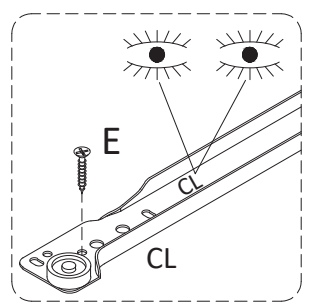
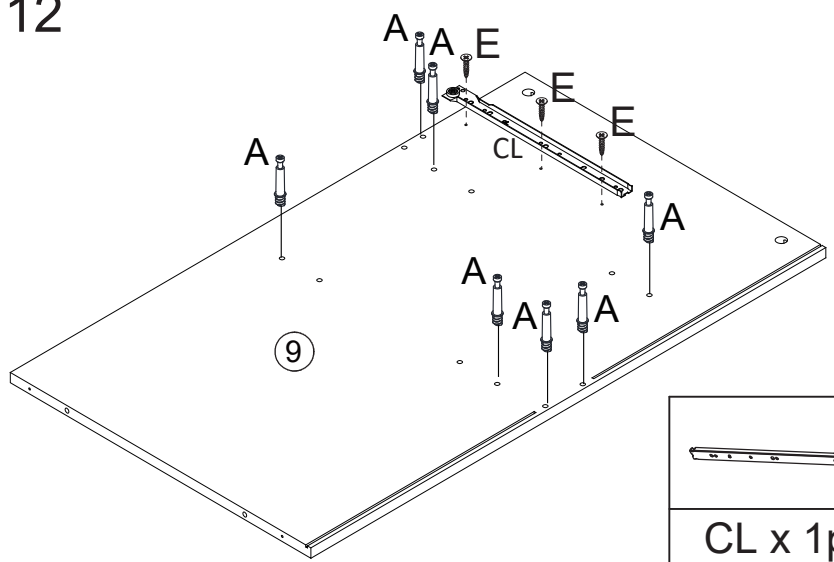

Step 12

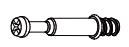

		
CL x 1pc	E x 3pcs	A x 7pcs

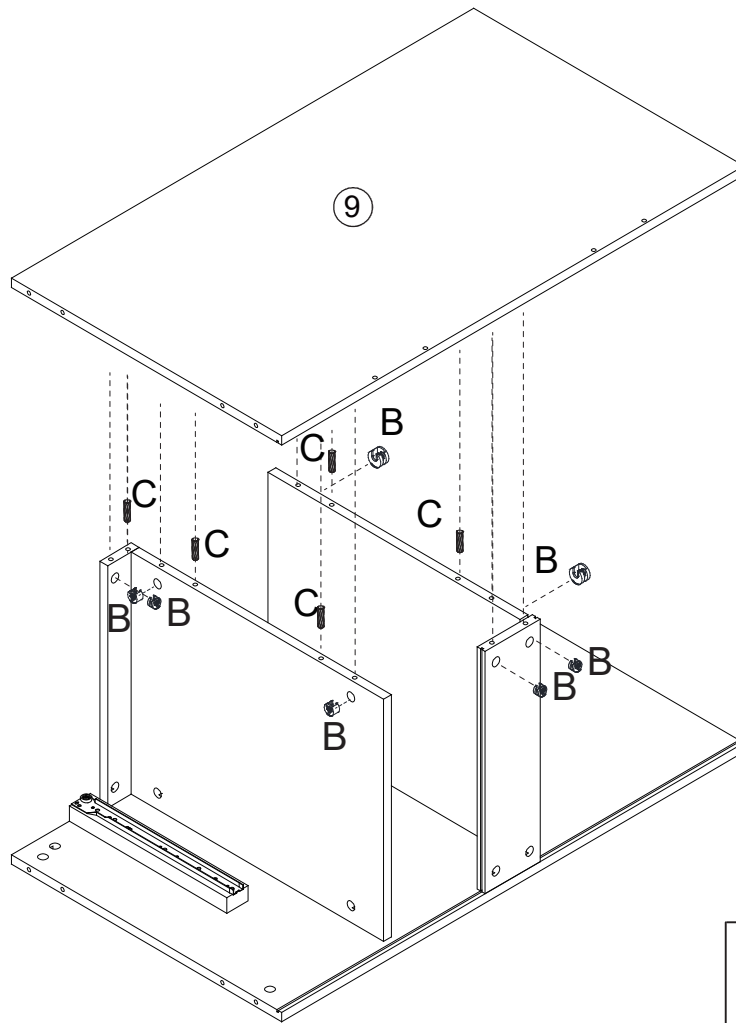
Step 13



	
C x 5pcs	B x 7pcs

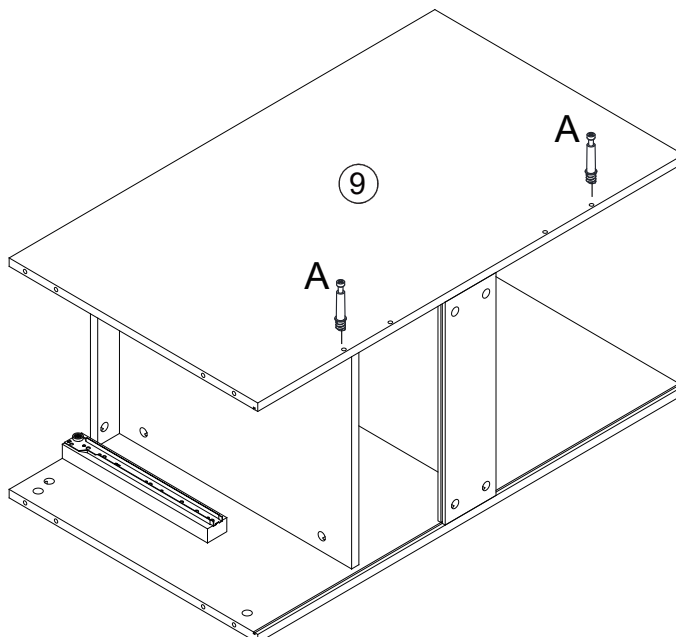

Step 14



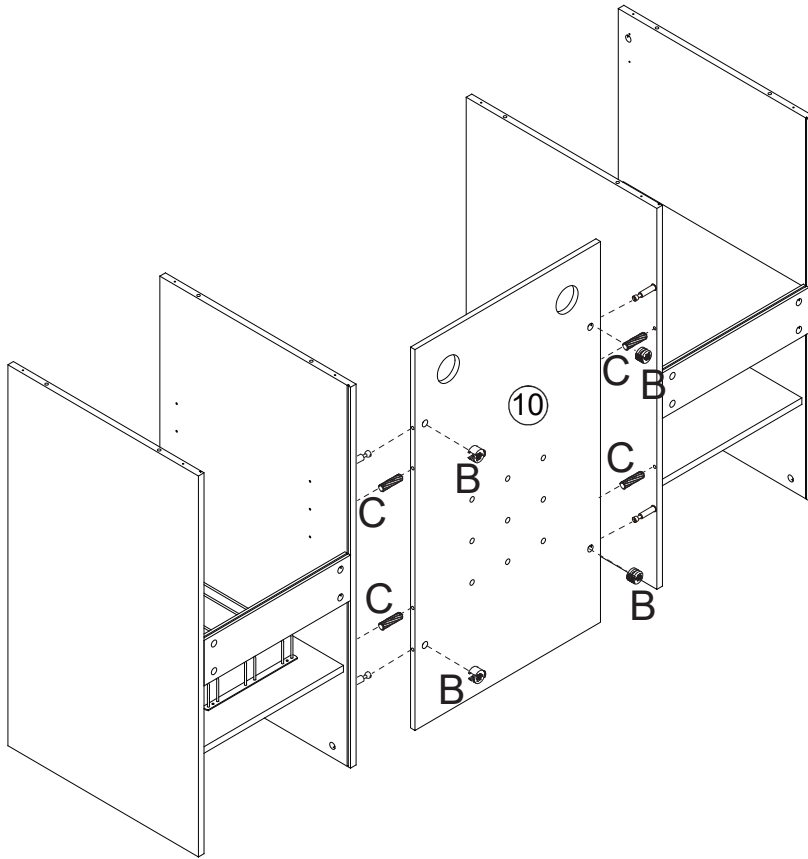

A x 2pcs

Step 15

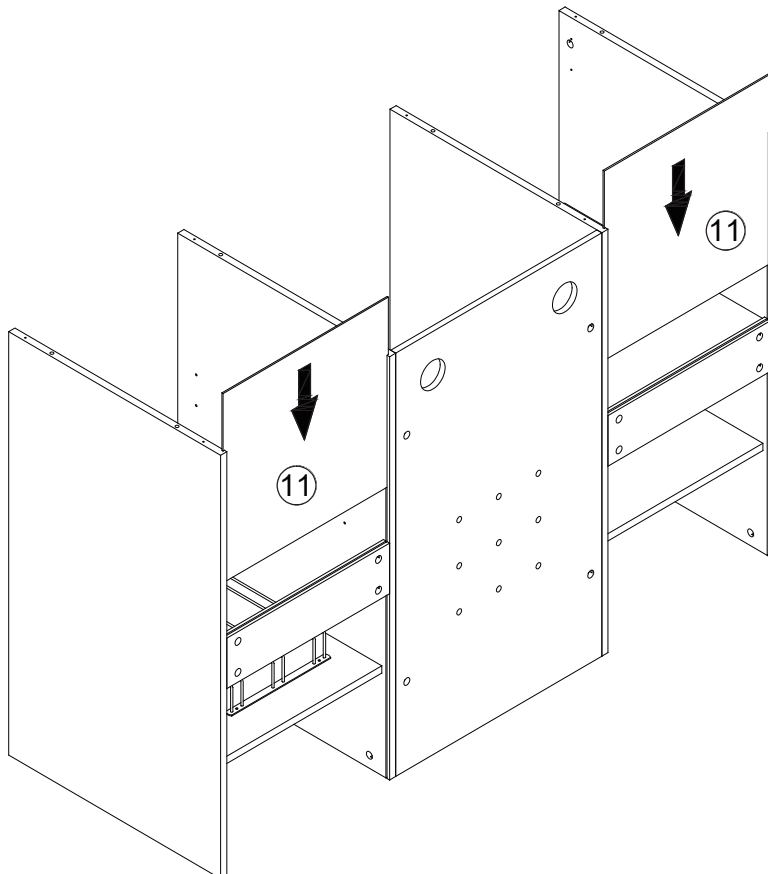

	
C x 4pcs	B x 4pcs

Step 16



Step 17

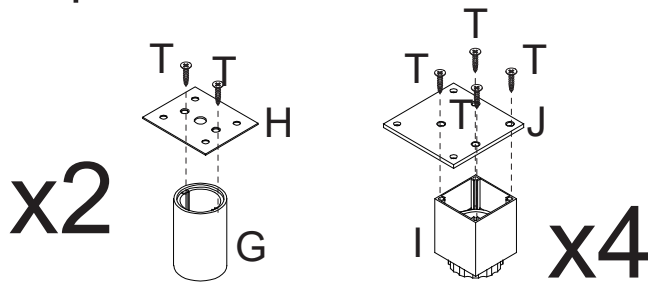

G x 2pcs	H x 2pcs
T x 20pcs	I x 4pcs
	J x 4pcs

Step 18

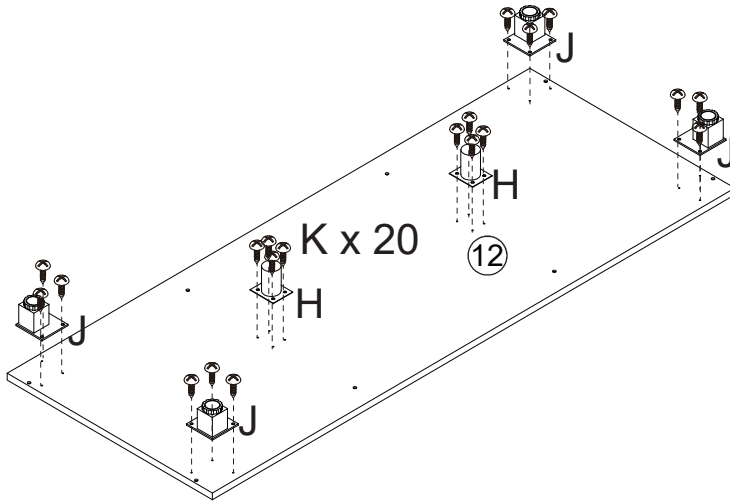

K x 20pcs

Step 19

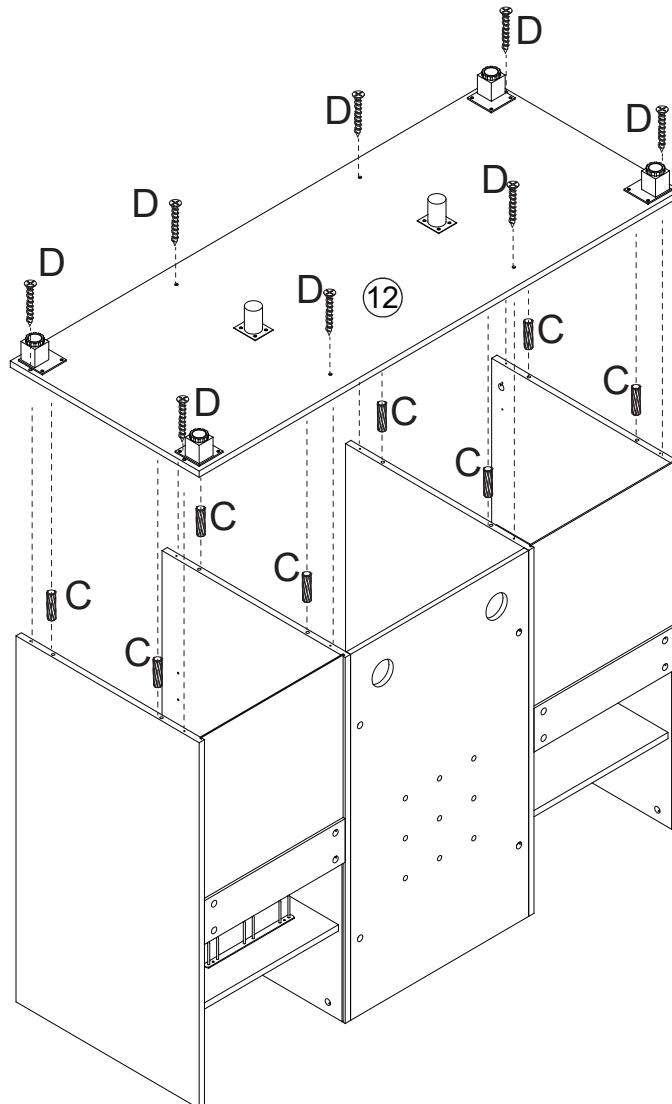



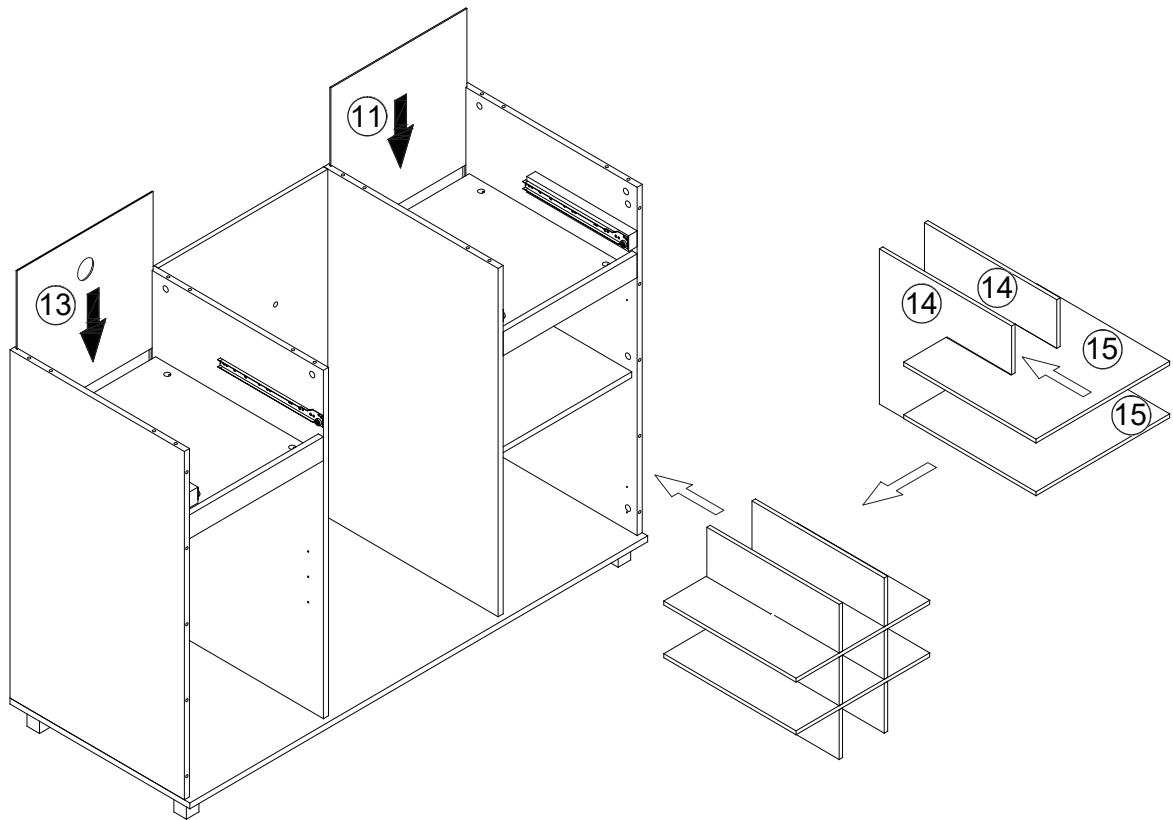

C x 8pcs	D x 8pcs

Step 20

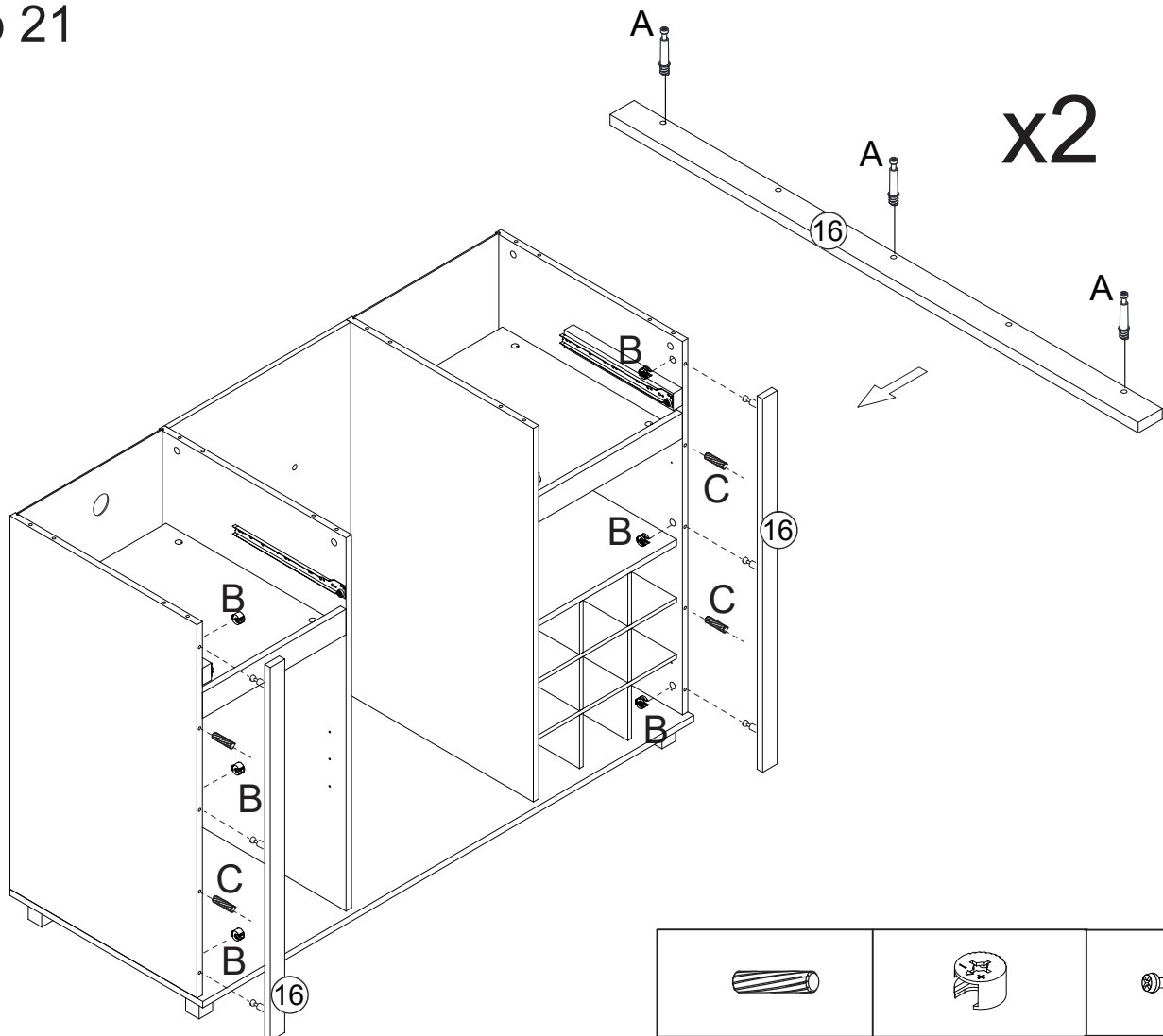

Step 21



		
C x 4pcs	B x 6pcs	A x 6pcs

Step 22

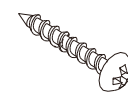
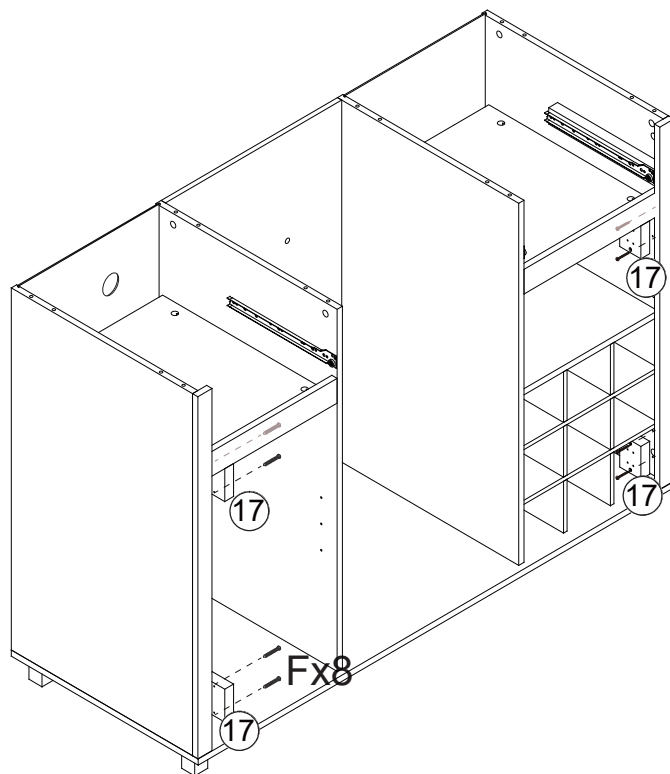

F x 8 pcs

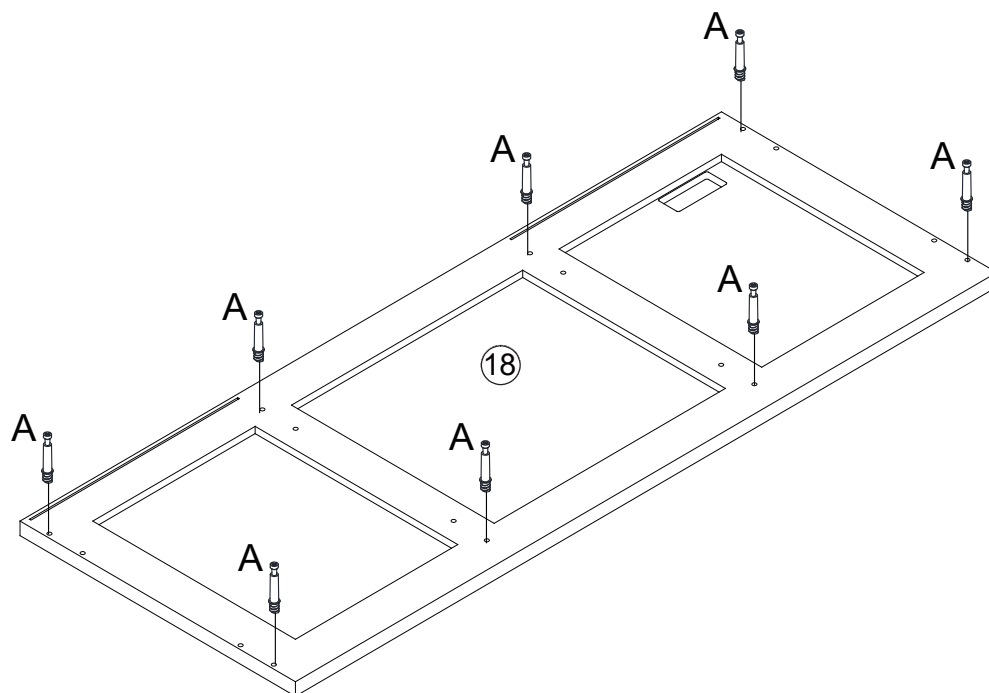

Step 23



A x 8 pcs

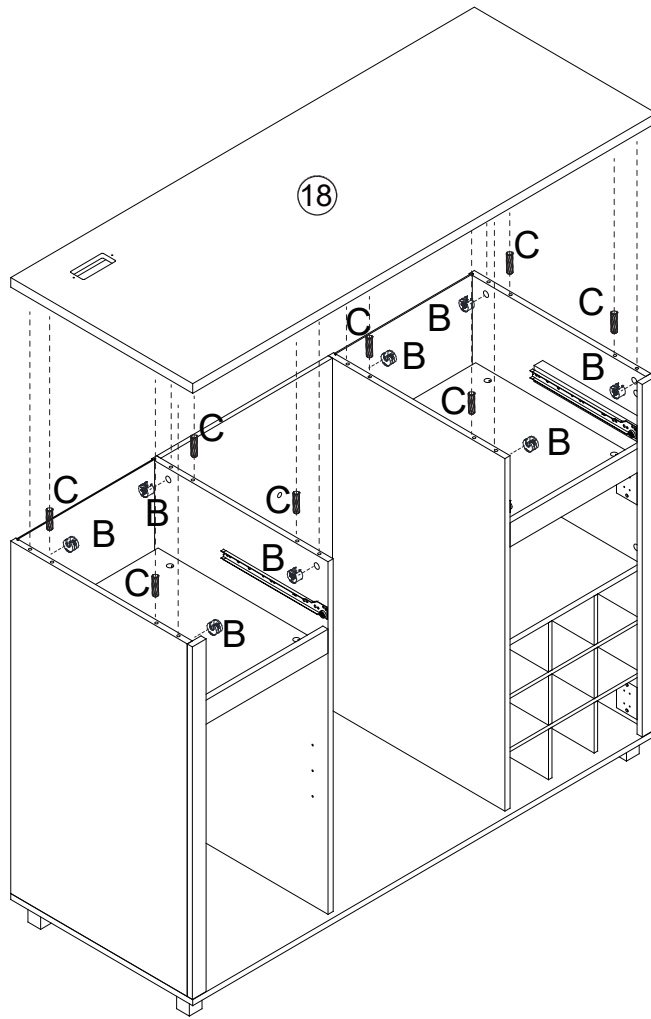

Step 24

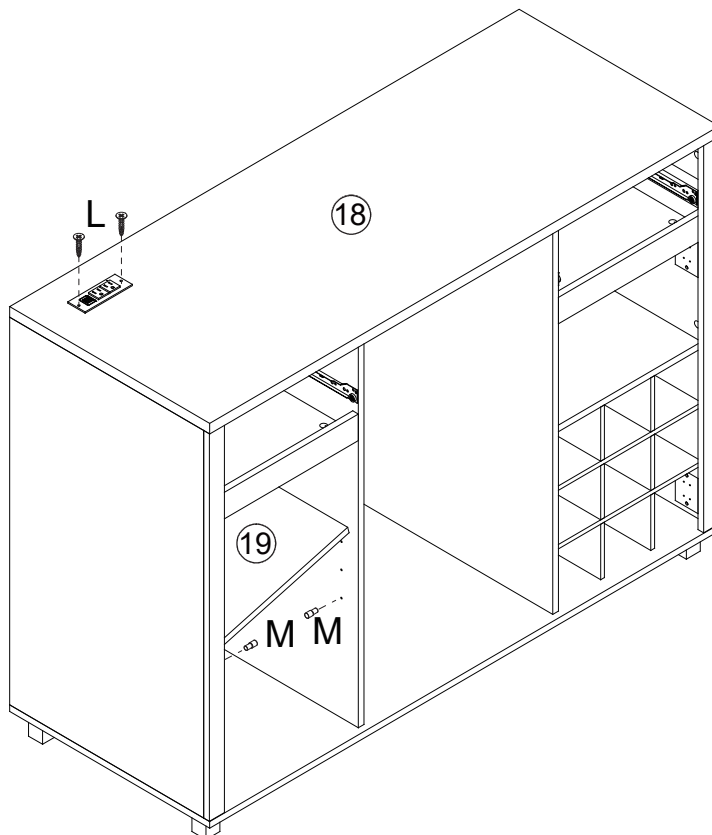

	
C x 8pcs	B x 8pcs

Step 25

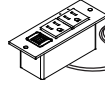





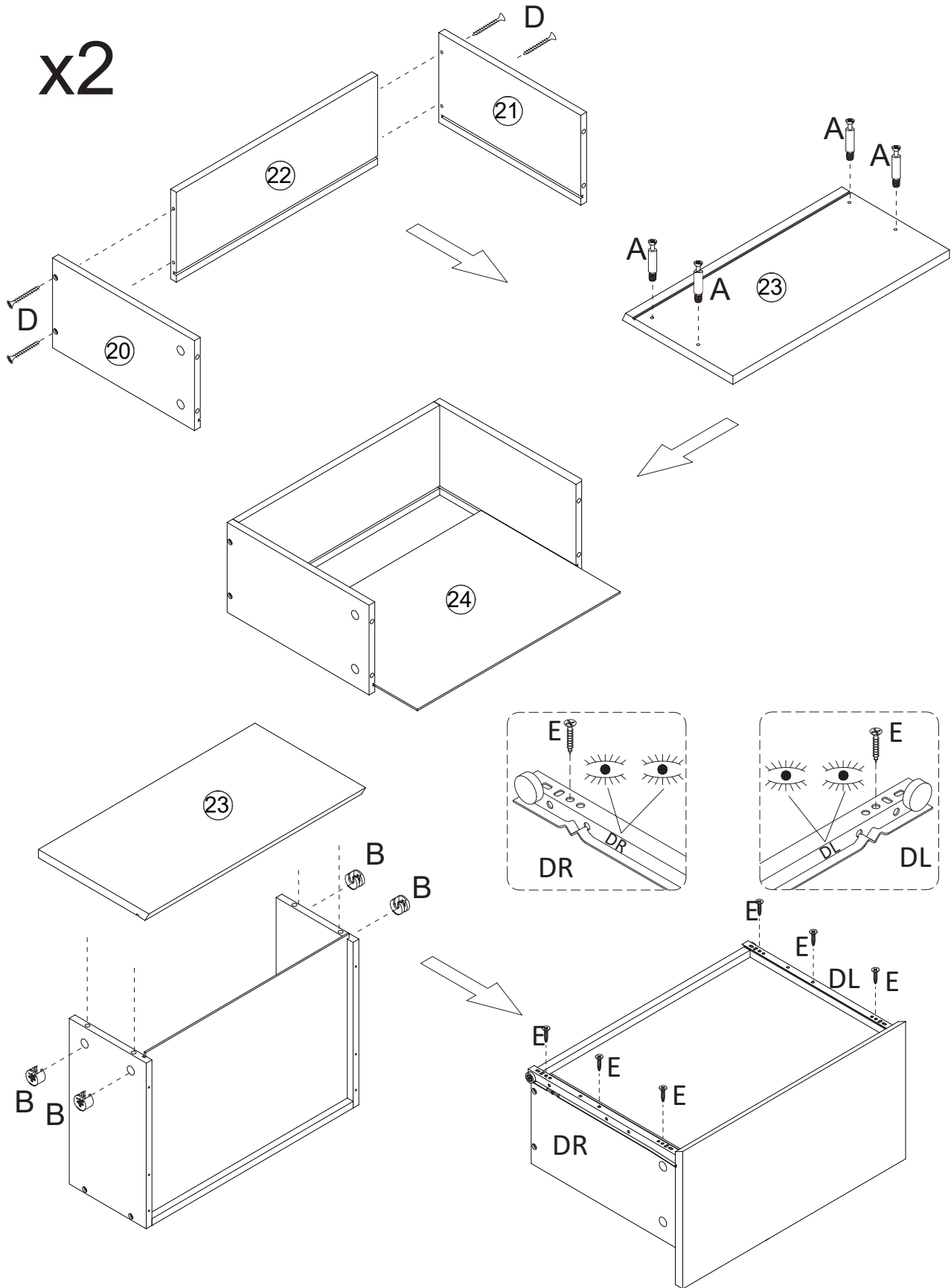

	
L x 1pc	M x 4pcs

Step 26

x2

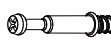

					
D x 8pcs	E x 12pcs	DLx 2pcs	DR x 2pcs	A x 8pcs	B x 8pcs

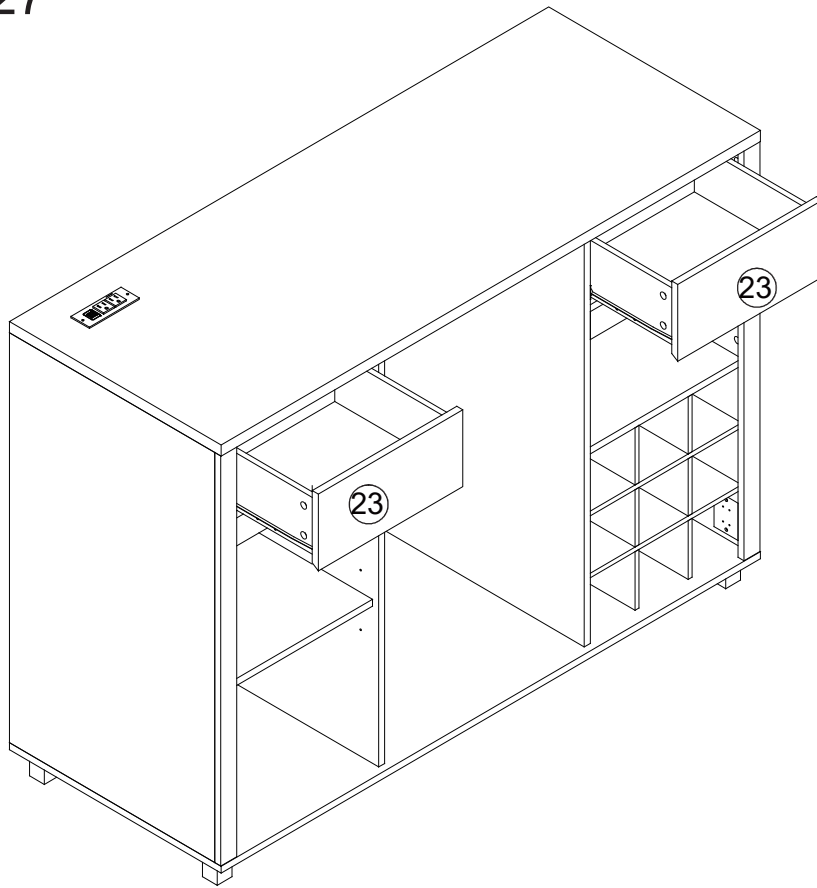

Step 27

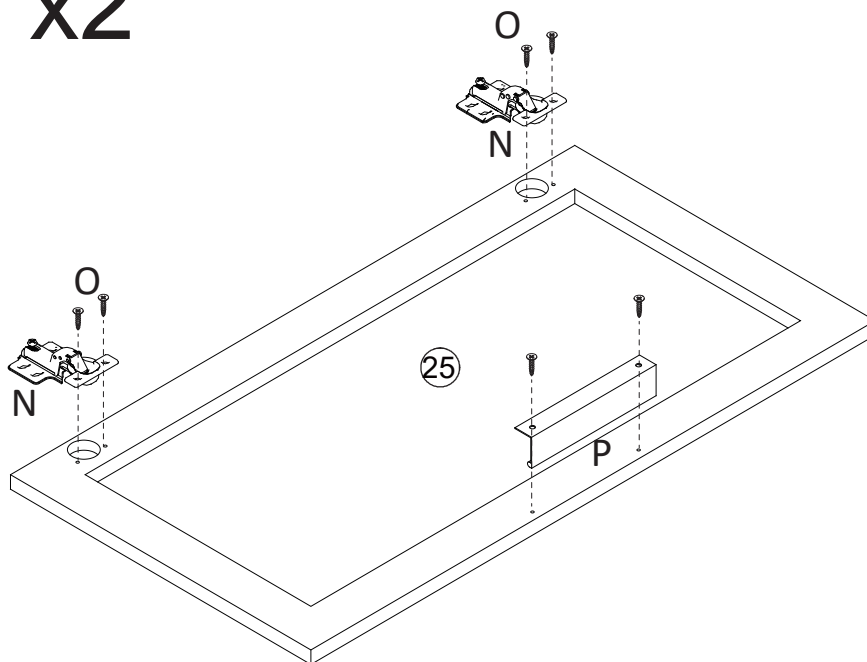

Step 28

x2

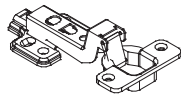

		
N x 4pcs	O x 8pcs	P x 2pcs

Step 29

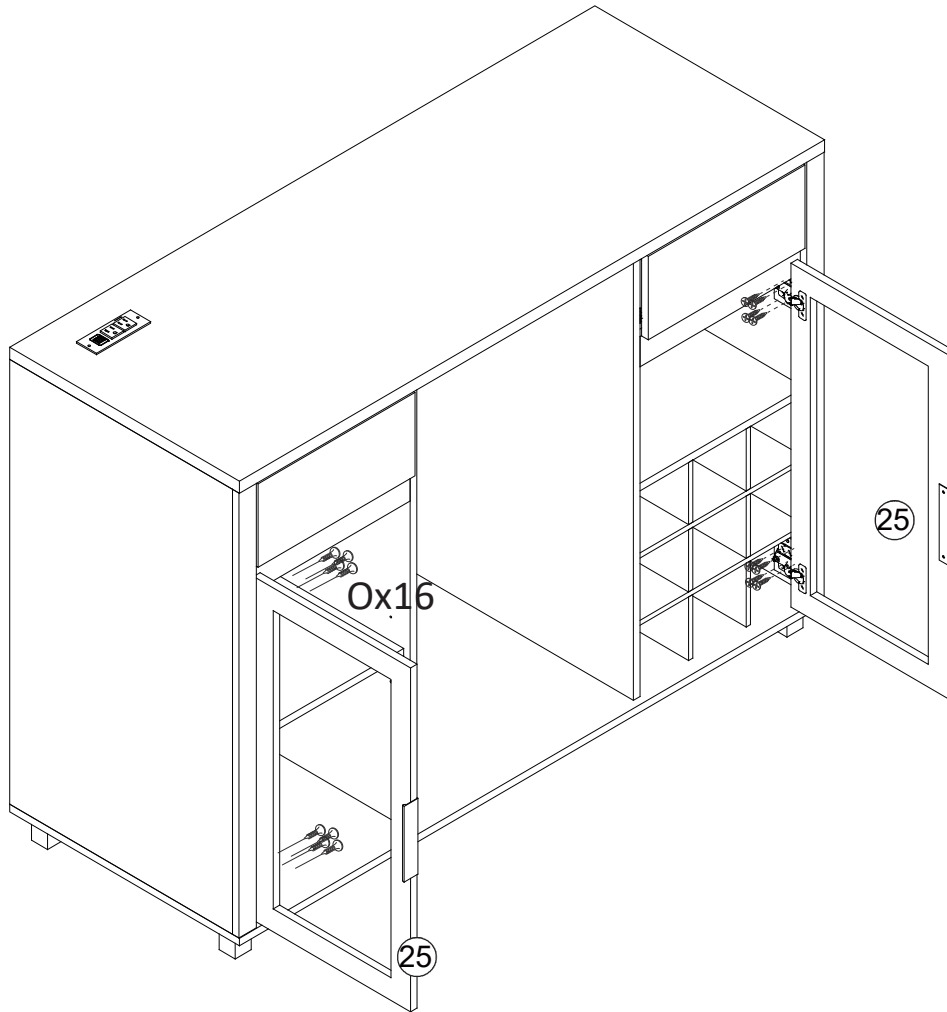

O x 16pcs

ADJUSTING DOORS / AJUSTEMENT DES PORTES

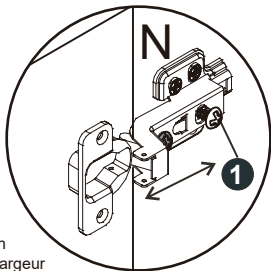

To adjust in width
Pour ajuster en largeur

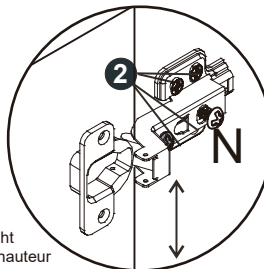

To adjust in height
Pour ajuster en hauteur

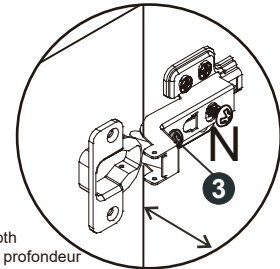

To adjust in depth
Pour ajuster en profondeur

Step 30

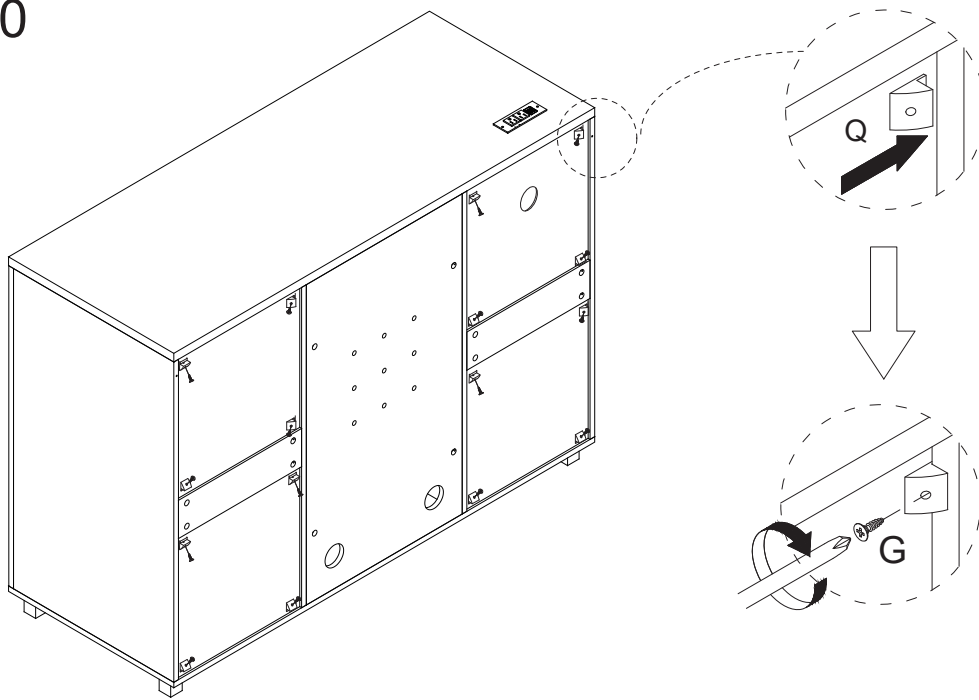

Q x 16pcs

Step 31

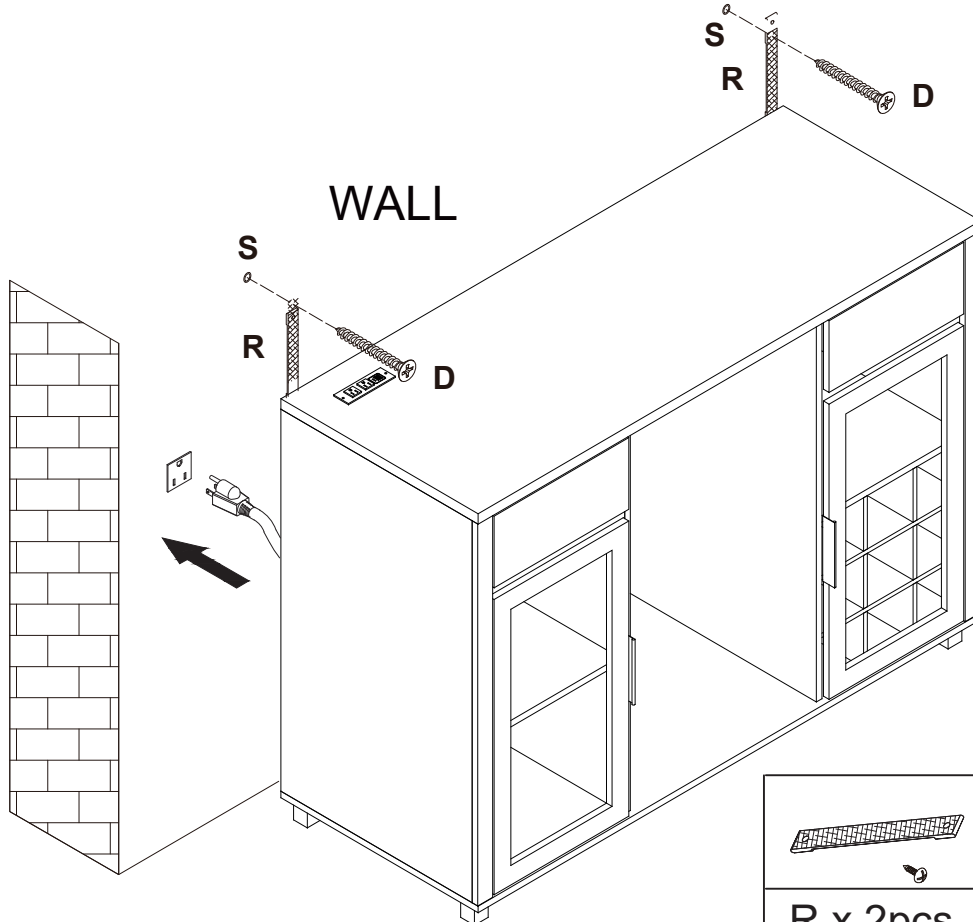
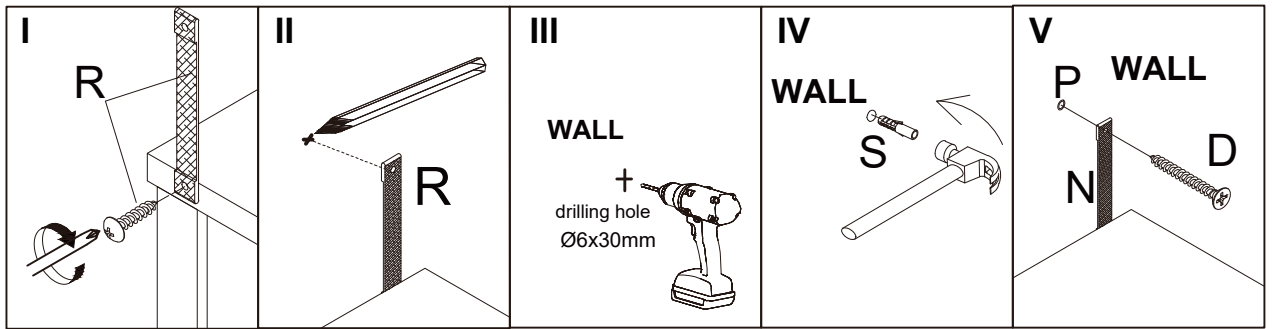

R x 2pcs	S x 2pcs	D x 2pcs