

# Storage Platform Bed-K Assembly Instructions

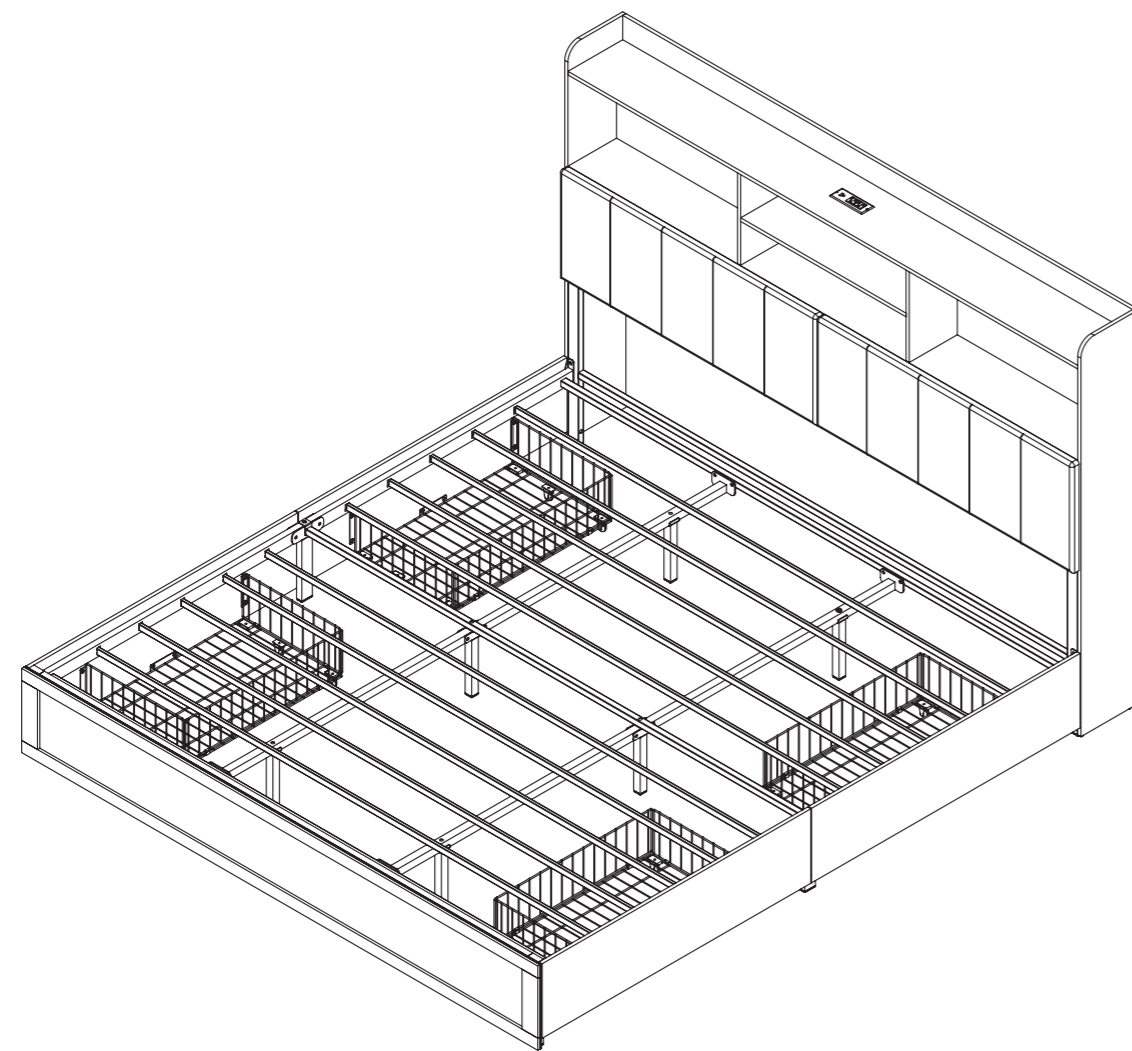

### Dear Customers,

Thank you for purchasing our product. Please read this instruction manual carefully after receiving this product. It will help you assemble this product quickly, safely and correctly. You can keep this manual for future reference.

MADE IN CHINA



Please follow the instruction manuals and use a pad to protect the product during your assembly.

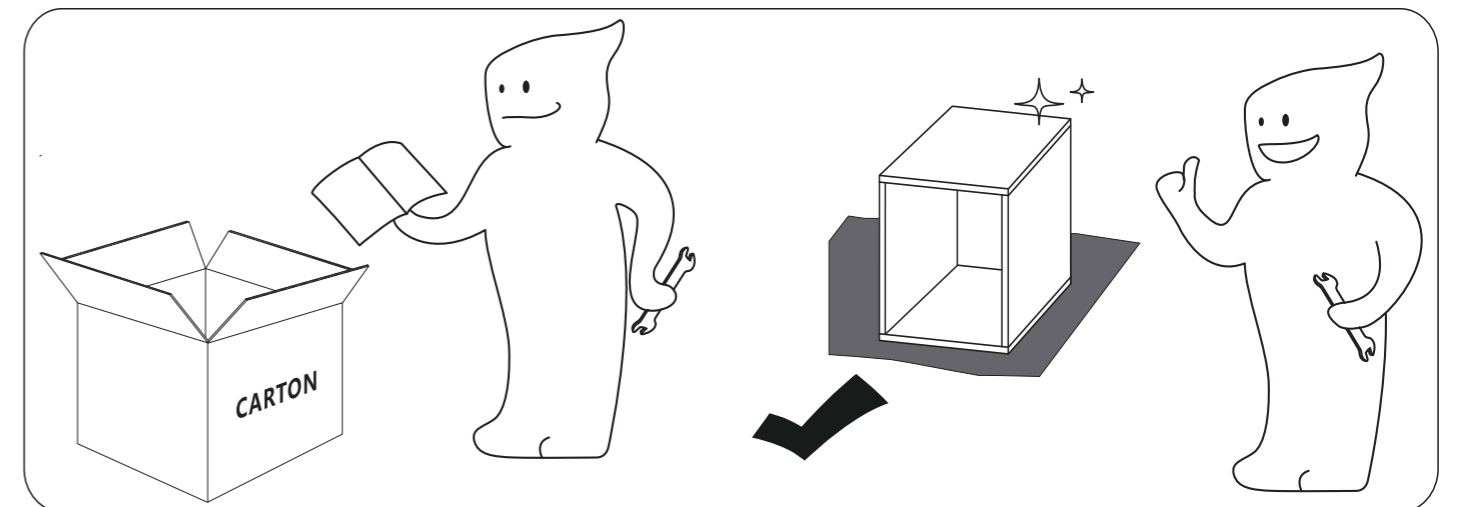
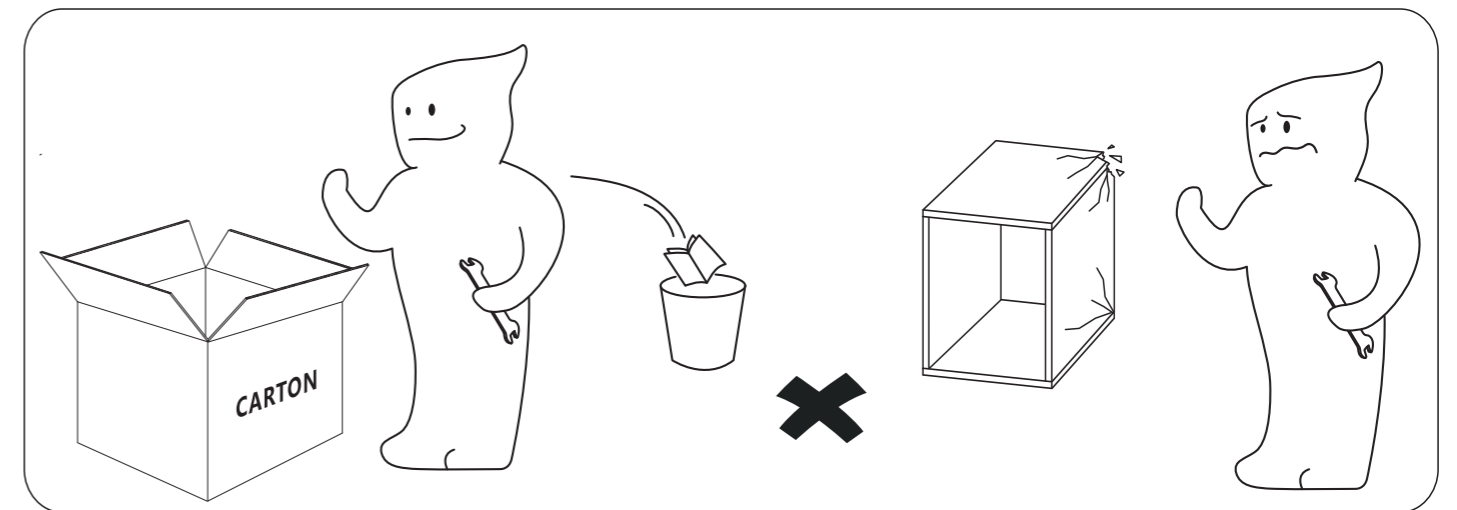

**Note:**

- 1. Should be assembled on flat ground to keep balance.
- 2. Before completing the installation, do not tighten the screws.



For easier and better assembly, 2 or more adults are required.

# ASSEMBLY INSTRUCTIONS

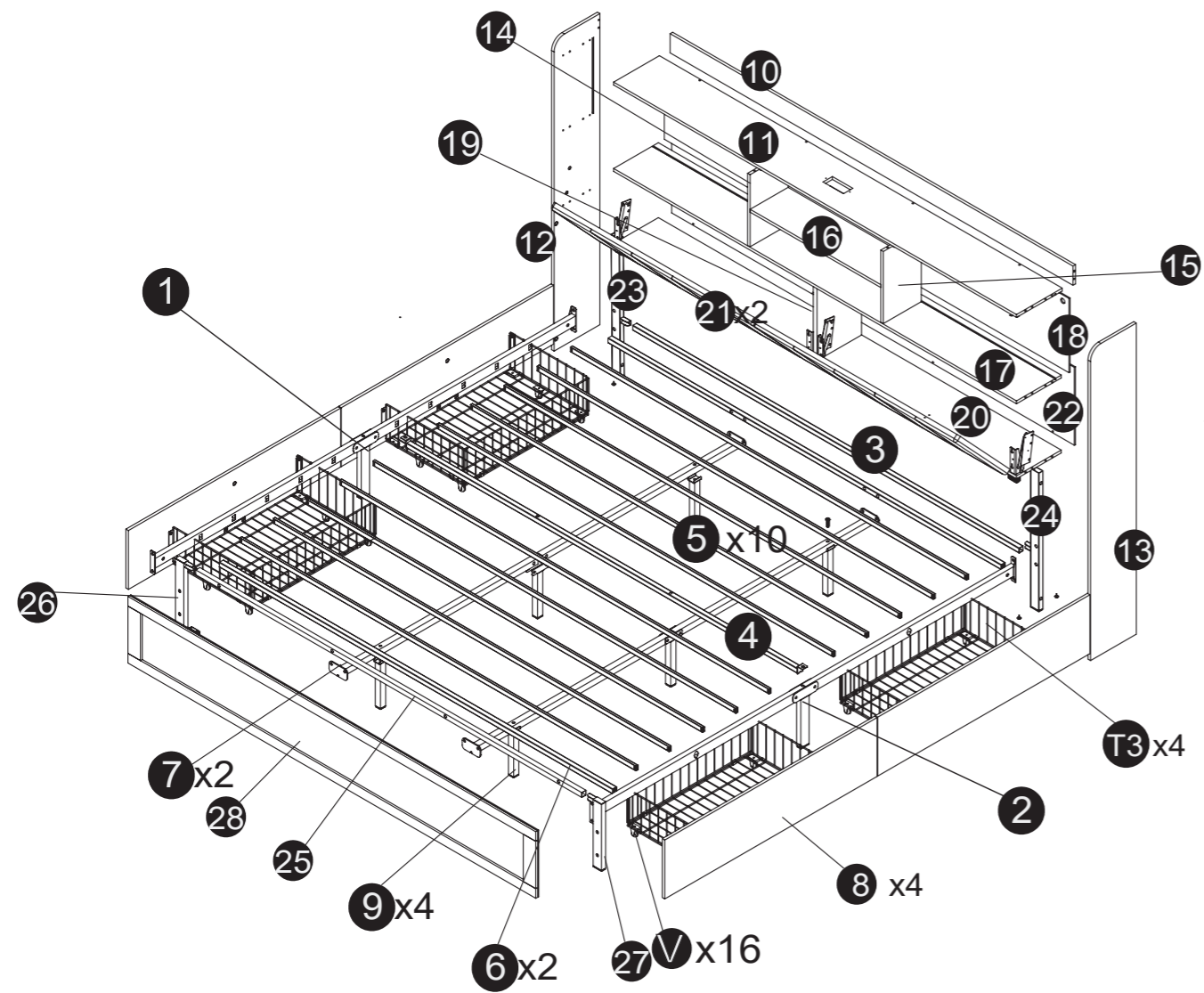







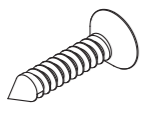

# ASSEMBLY INSTRUCTIONS

## The box 1

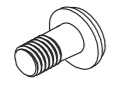
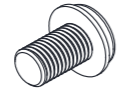
1  1PC	2  1PC	7  2PCS
9  4PCS	8  4PCS	14  1PC
15  1PC	16  1PC	19  1PC
21  1PC	23  1PC	24  1PC
26  1PC	27  1PC	T3  4PCS
V  16PCS	J1  2PCS	J2  2PCS

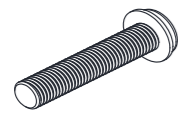
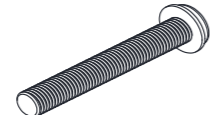
# ASSEMBLY INSTRUCTIONS

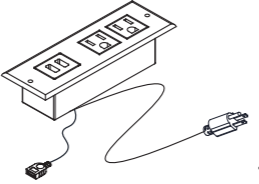
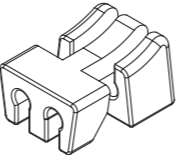
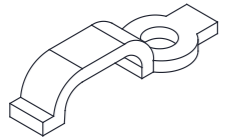
## The box 1 continued

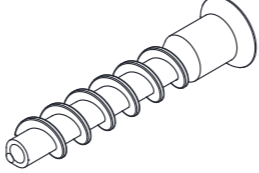
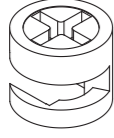
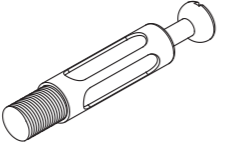
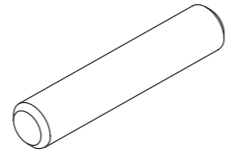
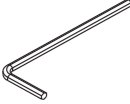
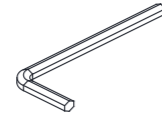
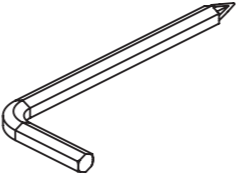
<b>A</b>  ST3.2x12 5PCS	<b>B</b>  ST4.2x12 2PCS	<b>C</b>  M8x12 white zinc 24PCS
<b>D</b>  M8x14 Colored Zinc 4PCS	<b>E</b>  M8x18 16PCS	<b>F</b>  M8x30 12PCS
<b>G</b>  M8x40 8PCS	<b>H</b>  M8x50 4PCS	<b>I</b>  M8x60 4PCS
<b>J</b>  M6x10 16PCS	<b>U</b>  1PC	<b>M</b>  8PCS
<b>N</b>  5PCS	<b>O</b>  M4x10 16PCS	<b>P</b>  M5x30 19PCS
<b>Q</b>  φ15x9.5 19PCS	<b>R</b>  φ7x40 19PCS	<b>S</b>  φ6x40 24PCS
<b>T</b>  M4 1PC	<b>W</b>  M5 1PC	<b>Y1</b>  M8 1PC

# ASSEMBLY INSTRUCTIONS

## The box 1 continued

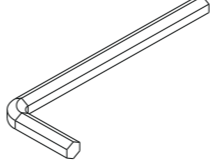
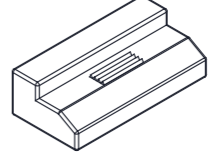
<b>Y2</b>  1PC	<b>Z</b>  20PCS	
---	--	--

Ruler - Use this ruler to help correctly identify the screws

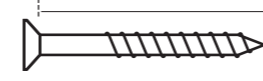



The length of the screw is measured from the rod part excluding the screw cap (30mm screw shown)

Please make sure to check that all screws are tightened after completing the entire installation.

# ASSEMBLY INSTRUCTIONS

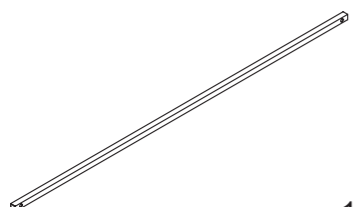
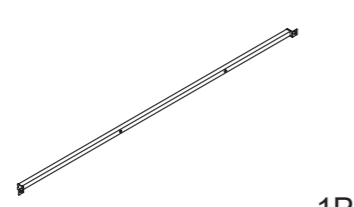
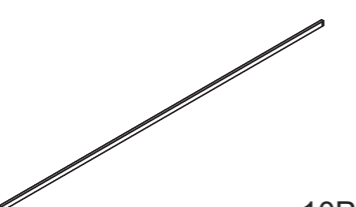
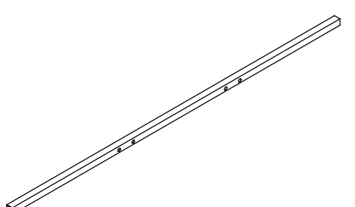
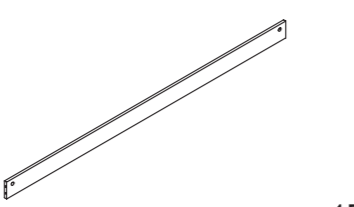
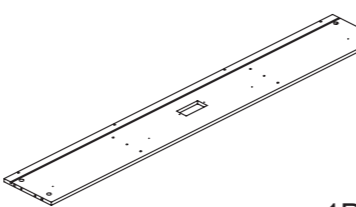
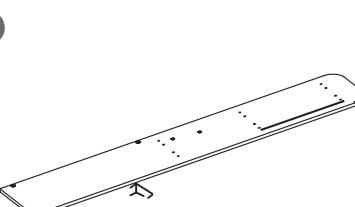
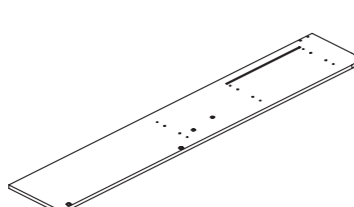
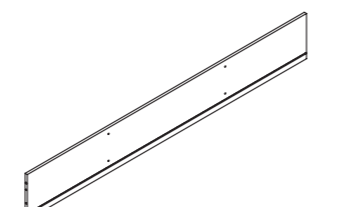
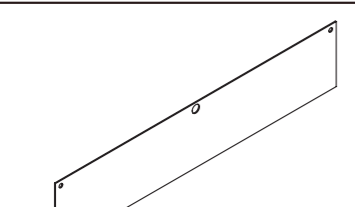
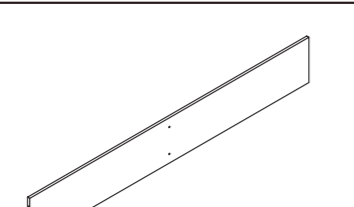
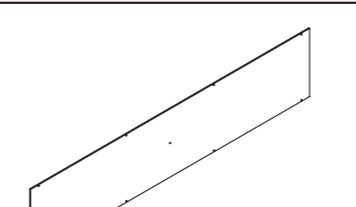
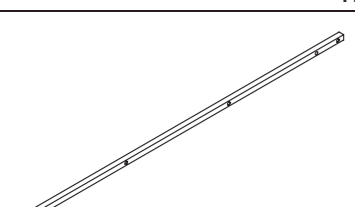
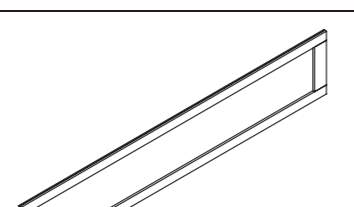
## The box 2

<b>3</b>  1PC	<b>4</b>  1PC	<b>5</b>  10PCS
<b>6</b>  2PCS	<b>10</b>  1PC	<b>11</b>  1PC
<b>12</b>  1PC	<b>13</b>  1PC	<b>17</b>  1PC
<b>18</b>  1PC	<b>20</b>  1PC	<b>22</b>  1PC
<b>25</b>  1PC	<b>28</b>  1PC	<b>K</b>  1PC

# ASSEMBLY INSTRUCTIONS

1

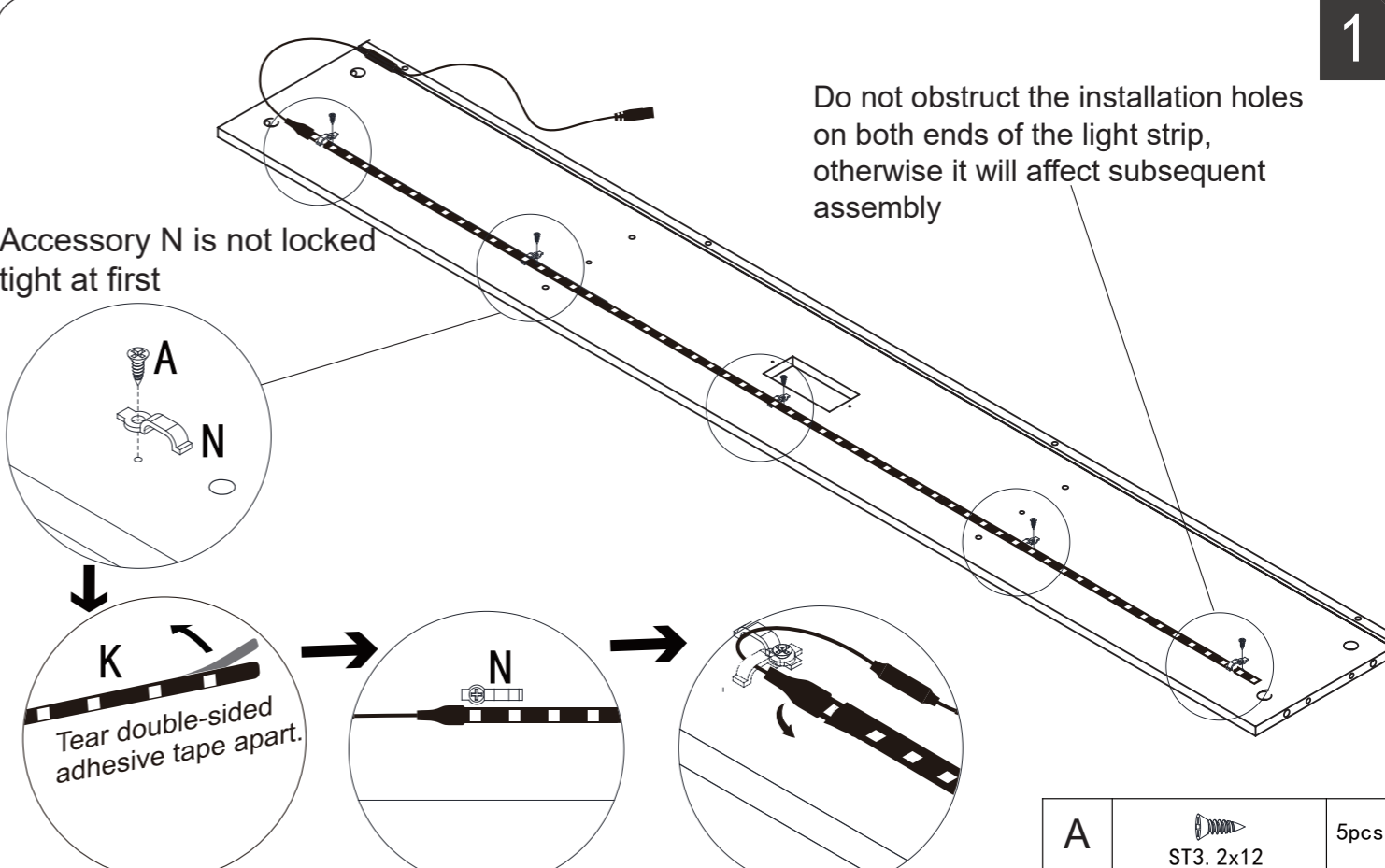

Do not obstruct the installation holes on both ends of the light strip, otherwise it will affect subsequent assembly

Accessory N is not locked tight at first

Tear double-sided adhesive tape apart.

Fastening accessories N

A		5pcs
	ST3. 2x12	

2

Note: Assemble with holes facing upwards

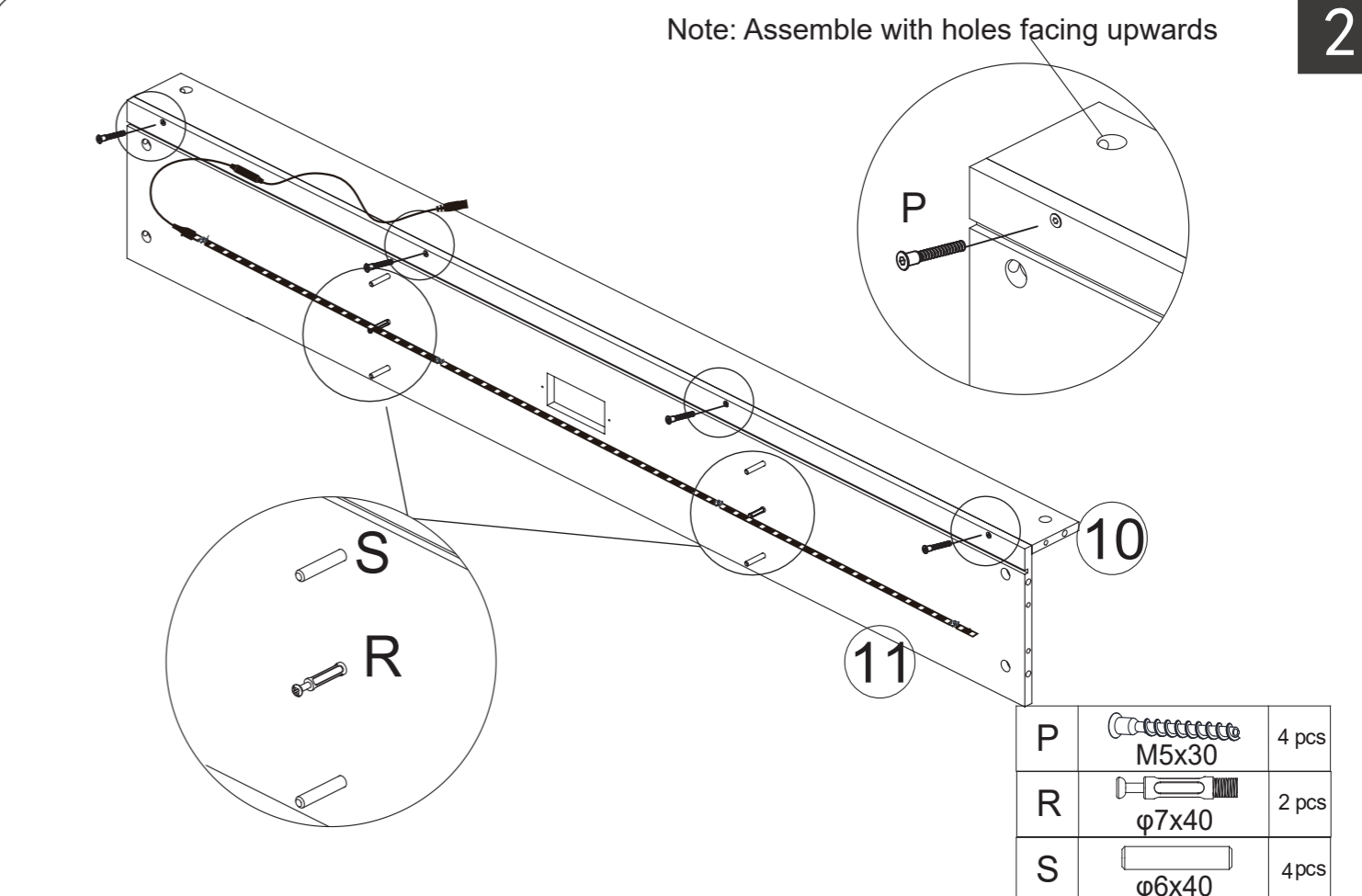

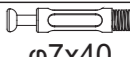
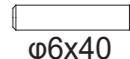
P		4 pcs
	M5x30	
R		2 pcs
	φ7x40	
S		4pcs
	φ6x40	

# ASSEMBLY INSTRUCTIONS

**3**

1 2 3

15 14 11 16

gap

Make sure the LED strip can pass through the gaps on parts 14 and 15

Q		φ15x9.5	4 pcs
R		φ7x40	2 pcs
S		φ6x40	4 pcs

**4**

Note: Assemble with holes facing upwards

Note that the grooves here should face each other as shown in the figure

P		M5x30	4 pcs
R		φ7x40	1 pcs
S		φ6x40	2 pcs

# ASSEMBLY INSTRUCTIONS

**5**

1 2 3

19

Note: Assemble with holes facing upwards

Q		φ15x9.5	1 pcs
---	--	---------	-------

**6**

Note: Assemble with holes facing upwards

Note that the direction of the hole on the part 18 as shown in the figure

P		M5x30	2 pcs
---	--	-------	-------

# ASSEMBLY INSTRUCTIONS

Do not tighten the screws at first.  
And making sure that the spring  
is assembled properly (as shown on the graph).

7

X2

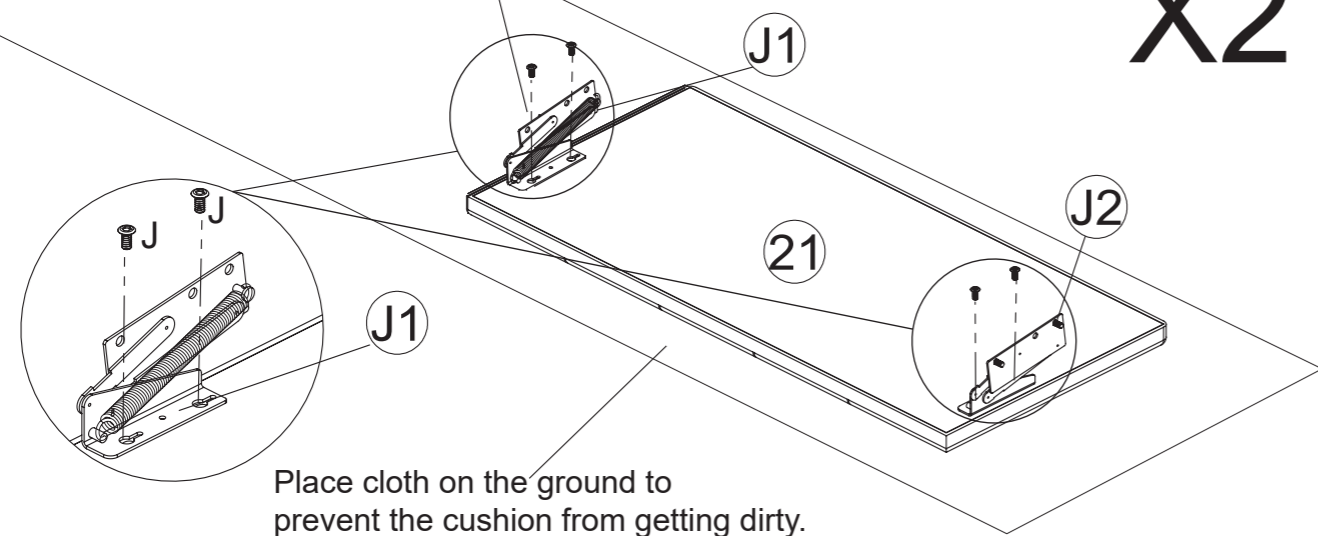

J		M6x10	8PCS
---	--	-------	------

# ASSEMBLY INSTRUCTIONS

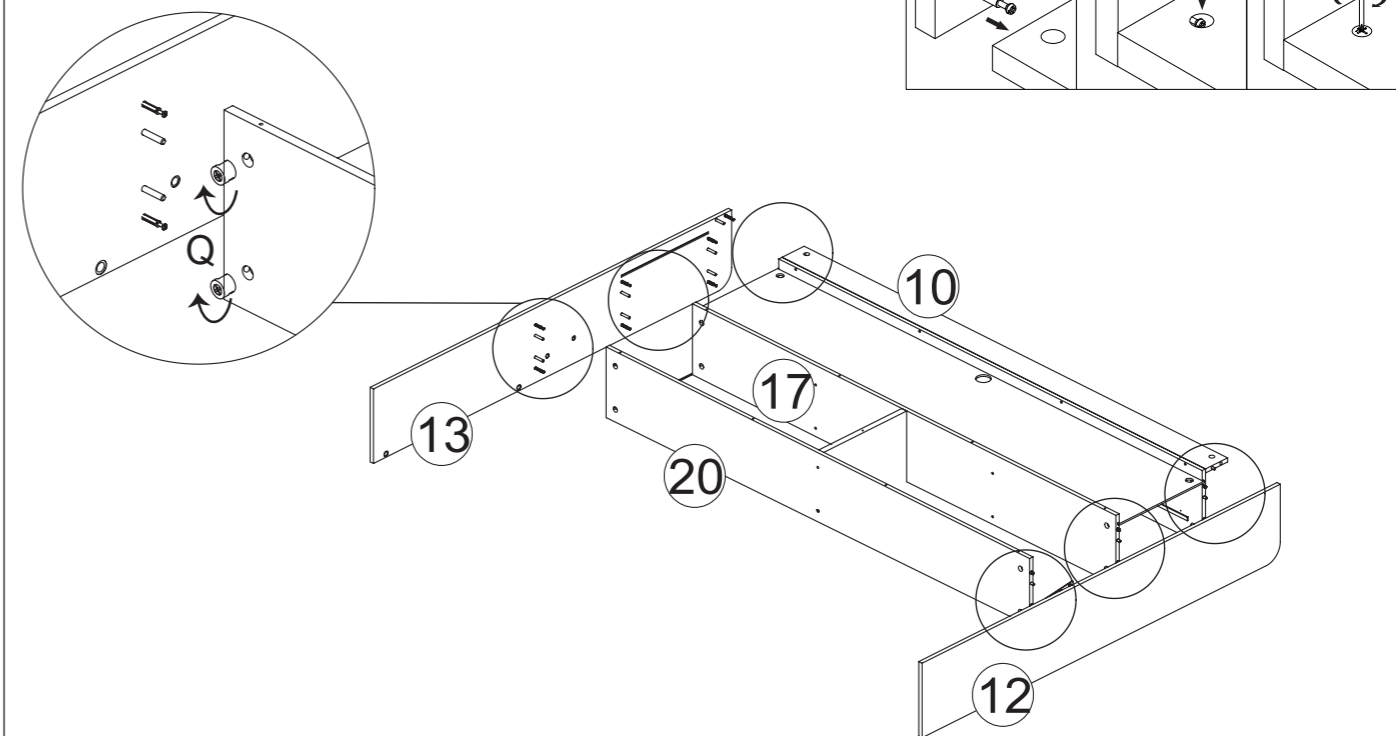

9

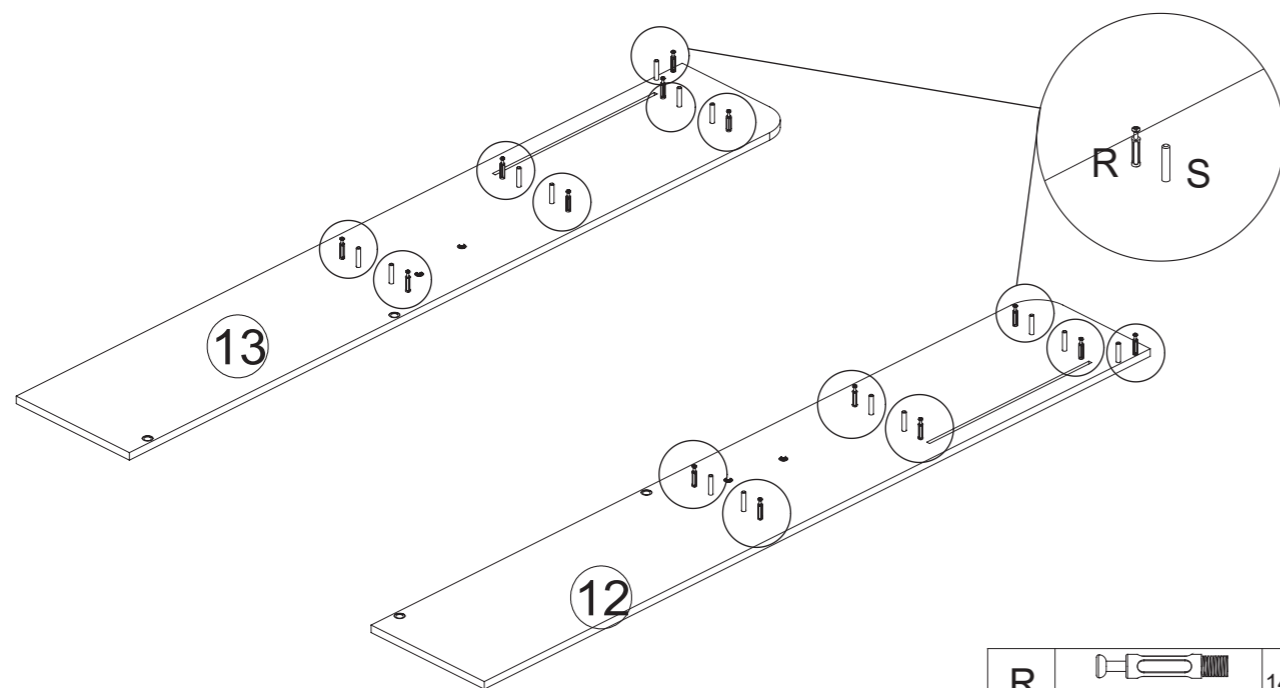

Q		φ15x9.5	10pcs
---	---	---------	-------

8



R		φ7x40	14pcs
S		φ6x40	14pcs

10

Make sure the hole positions of J1 and J2  
are aligned, it helps you to assemble easily.  
Note: Two components 21 are placed below  
components 13 and 12

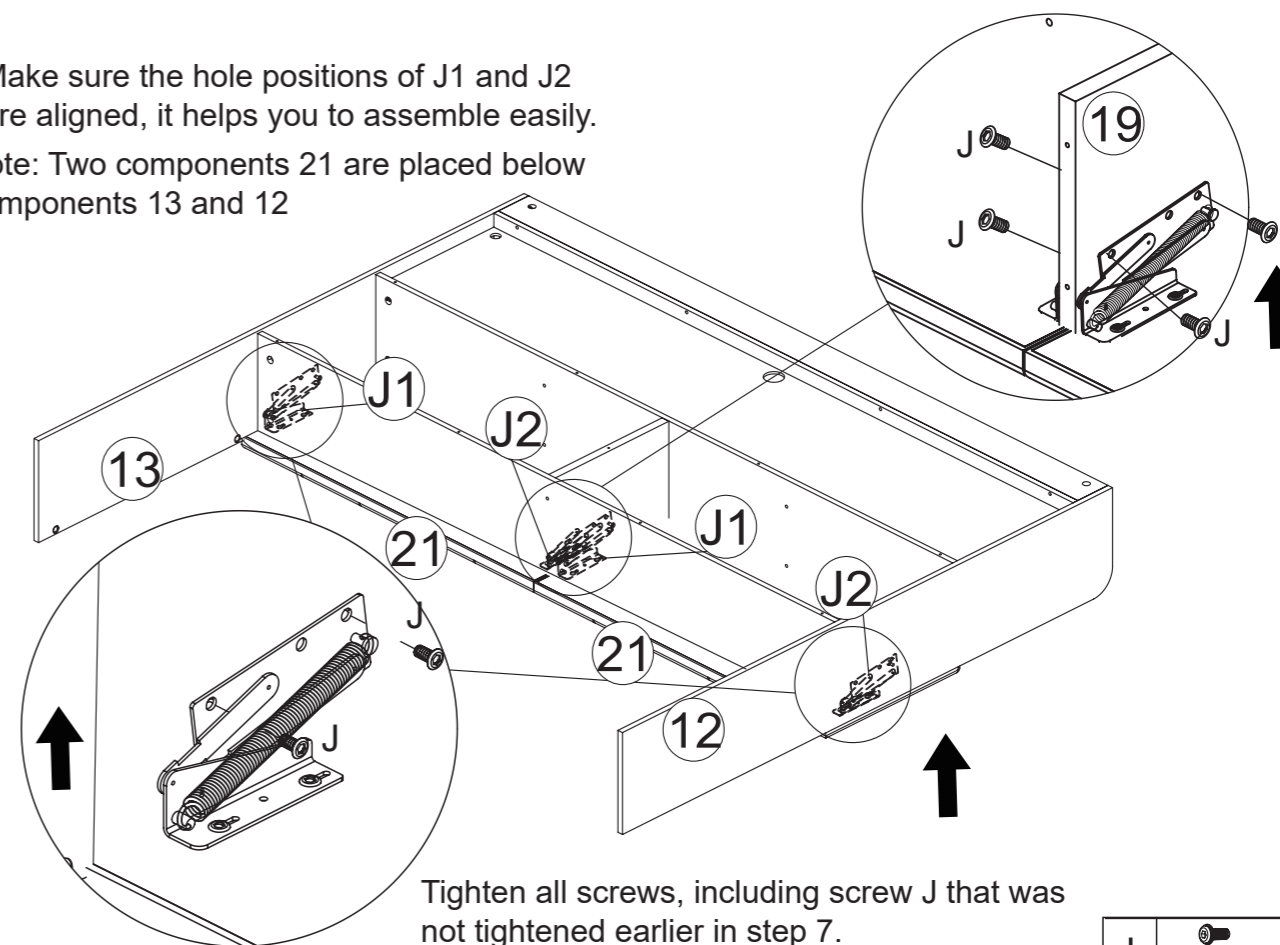

Tighten all screws, including screw J that was  
not tightened earlier in step 7.

J		M6x10	8PCS
---	---	-------	------

# ASSEMBLY INSTRUCTIONS

11

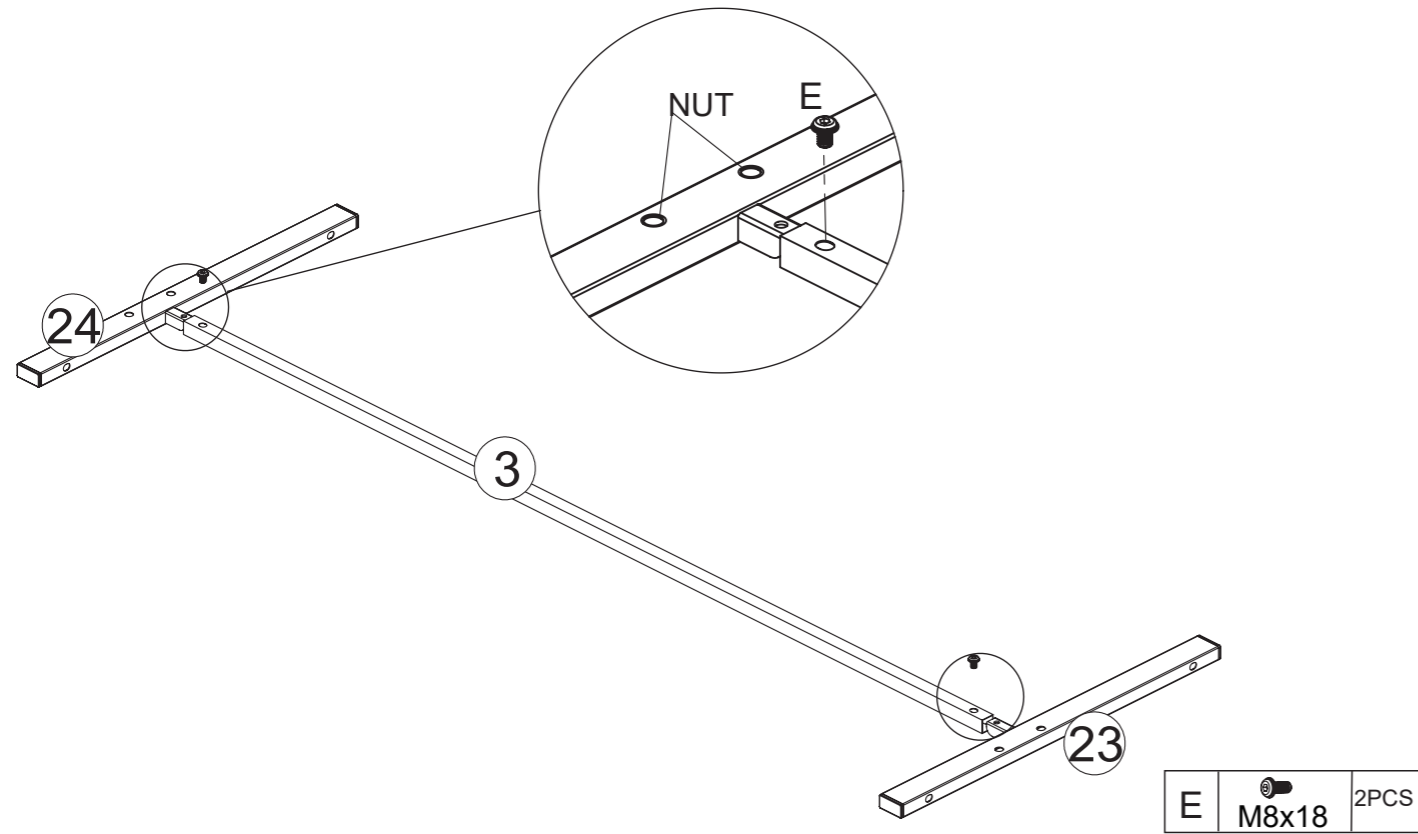

# ASSEMBLY INSTRUCTIONS

13

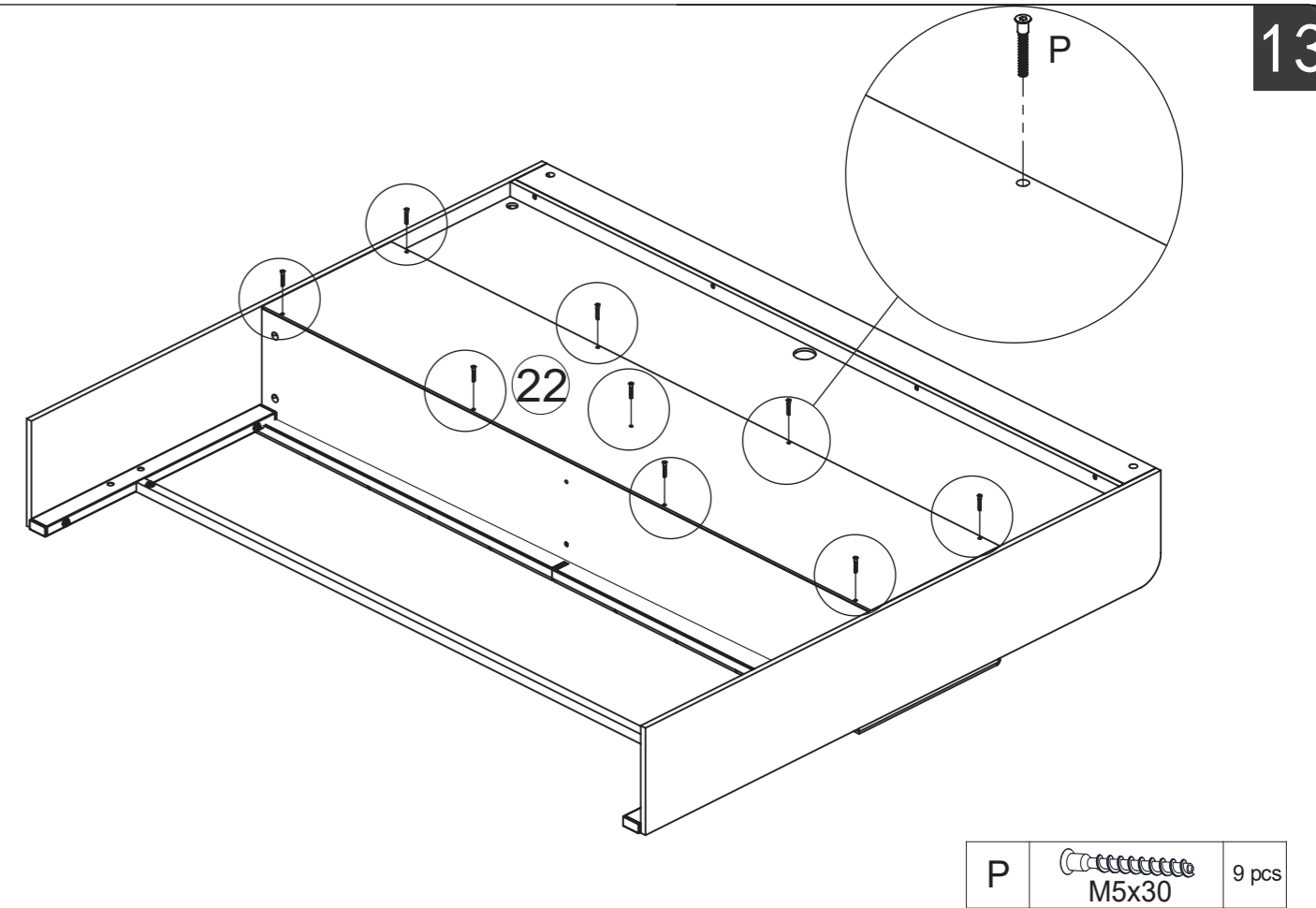

12

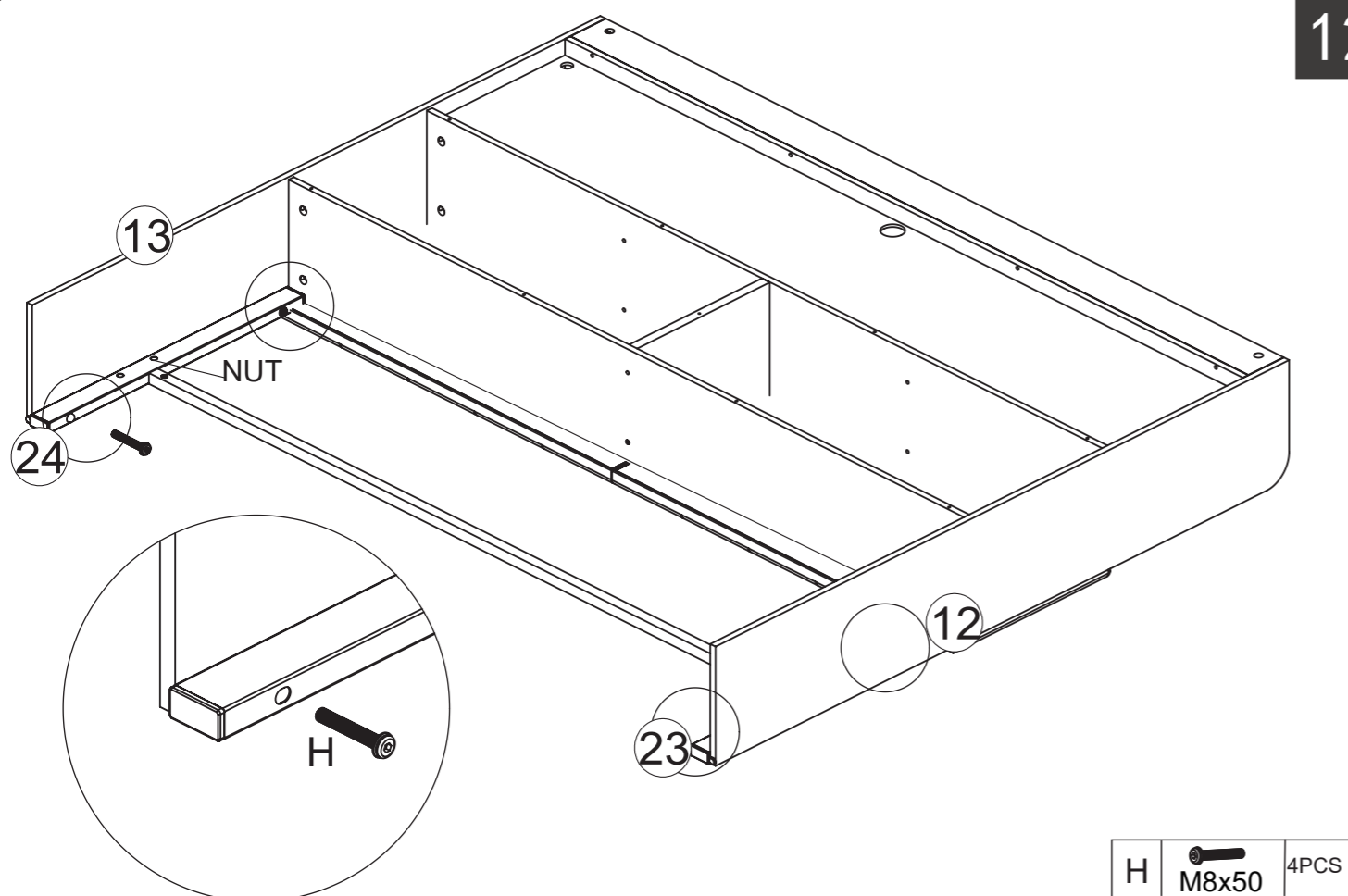

12/21

14

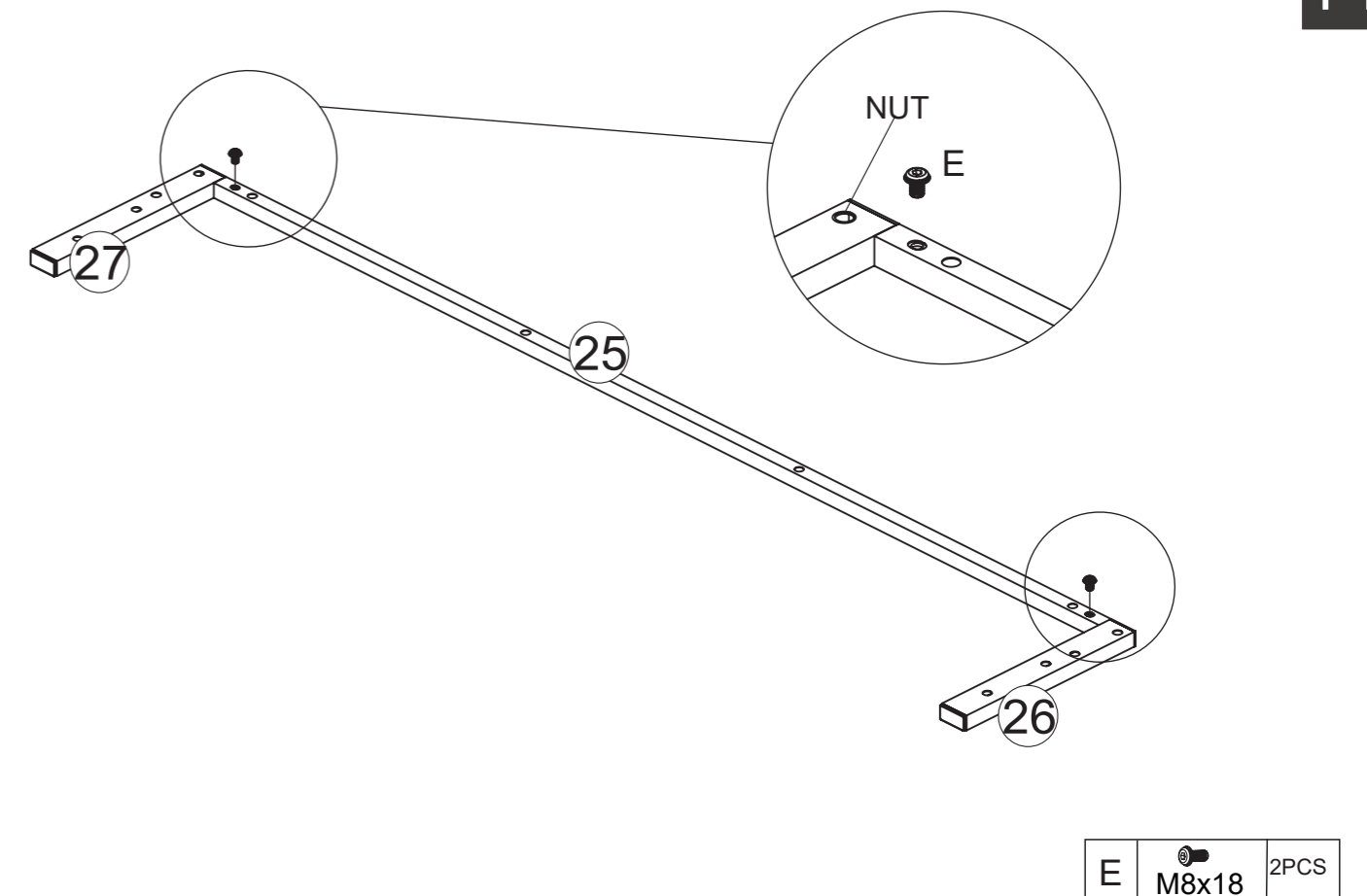

13/21

# ASSEMBLY INSTRUCTIONS

15

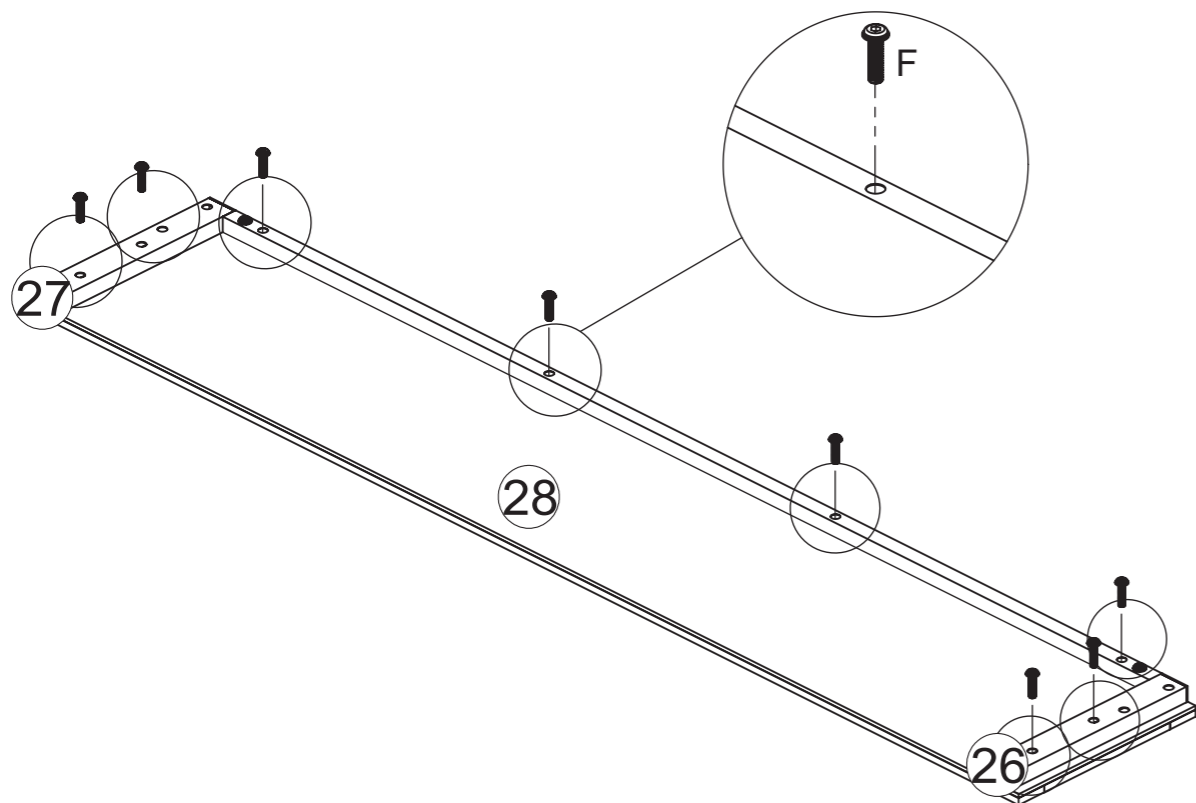

F M8x30 8PCS

# ASSEMBLY INSTRUCTIONS

17

X2

**WARNING!**  
Moving parts can crush or cut. Keep fingers, hands, and feet away to avoid injury

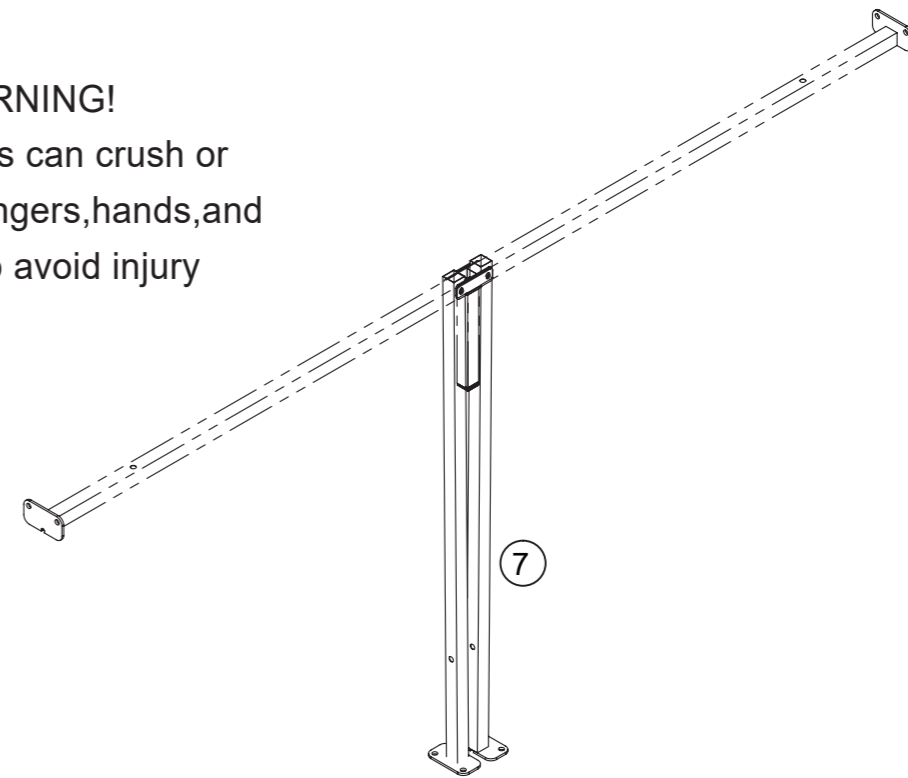

**WARNING!**

Moving parts can crush or cut. Keep fingers, hands, and feet away to avoid injury

16

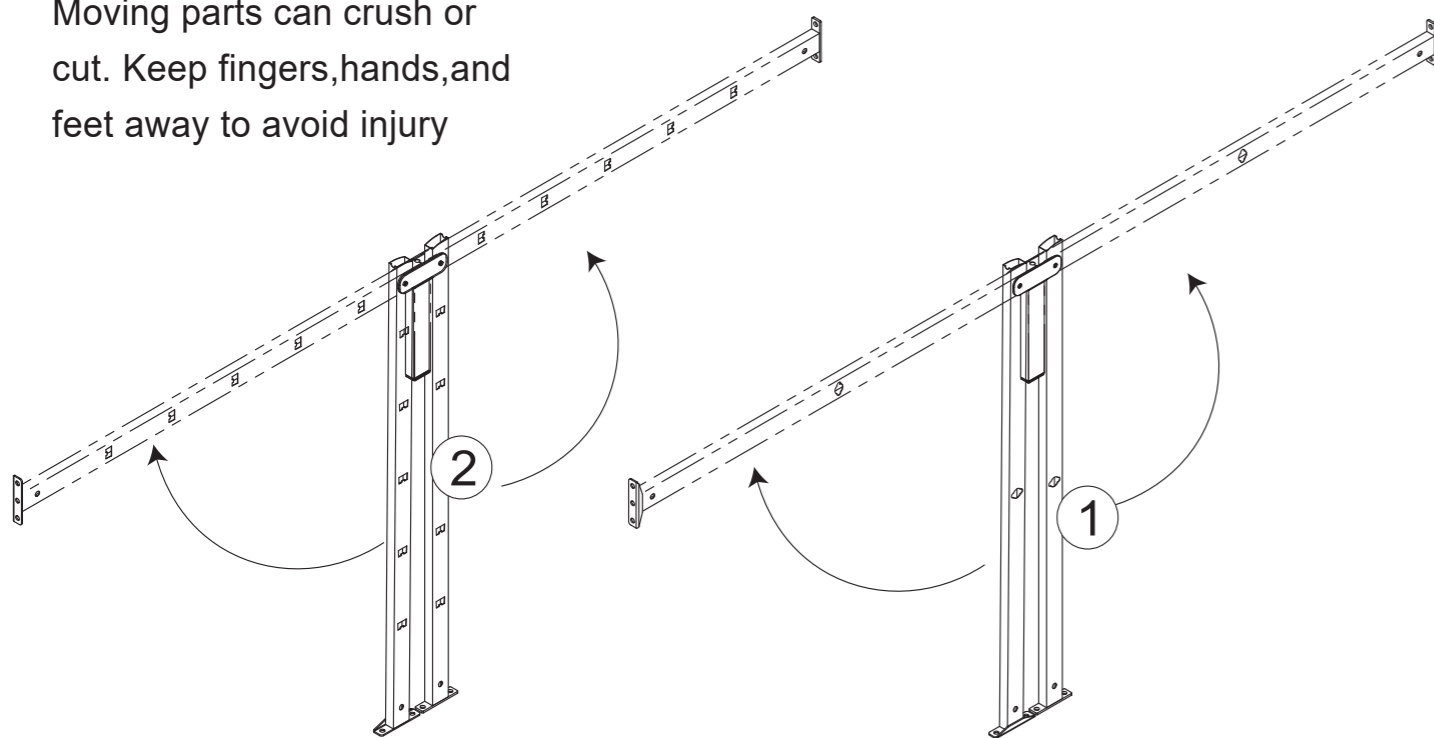

18

X2

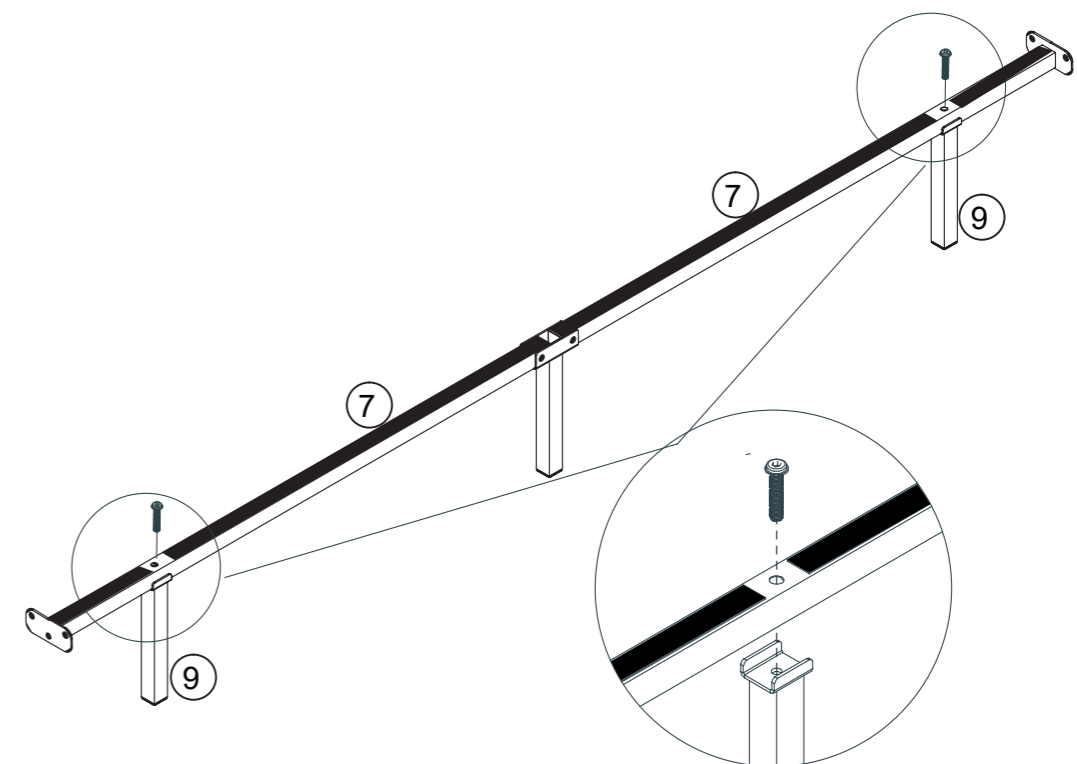

G M8x40 4PCS

# ASSEMBLY INSTRUCTIONS

19

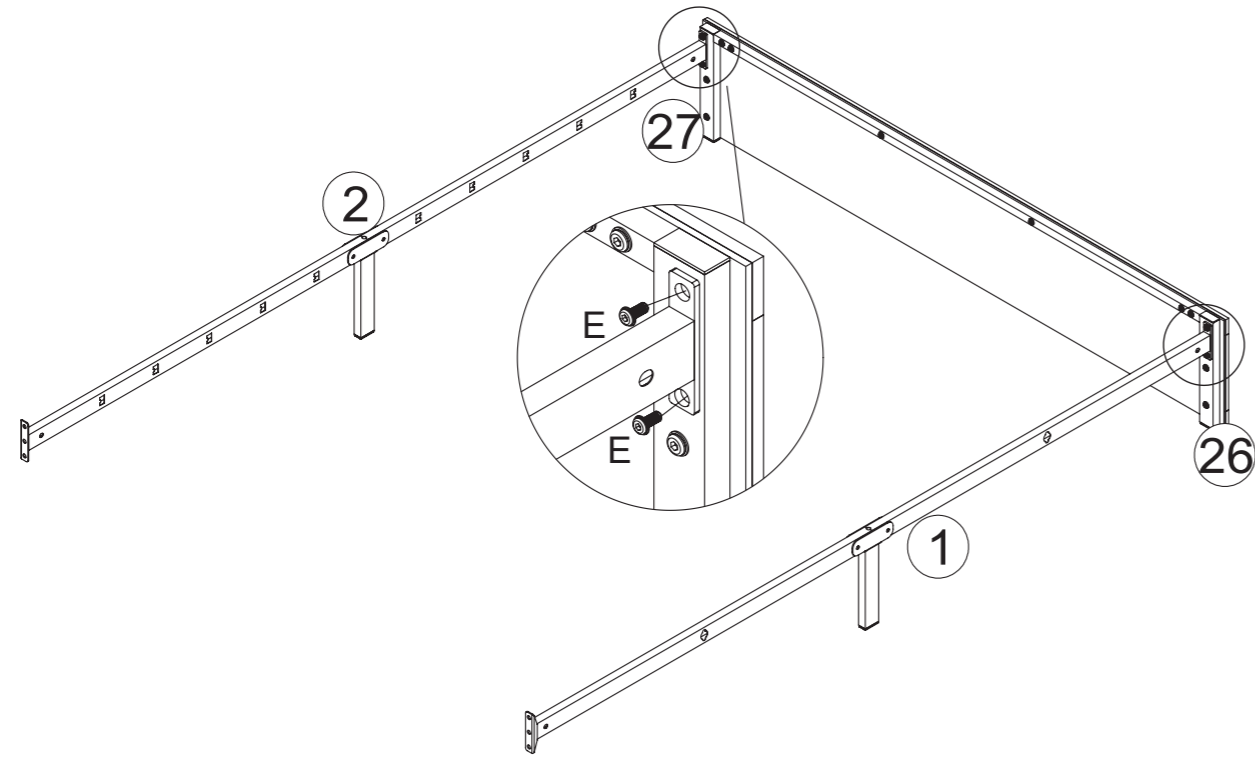

E		M8x18	4PCS
---	--	-------	------

# ASSEMBLY INSTRUCTIONS

21

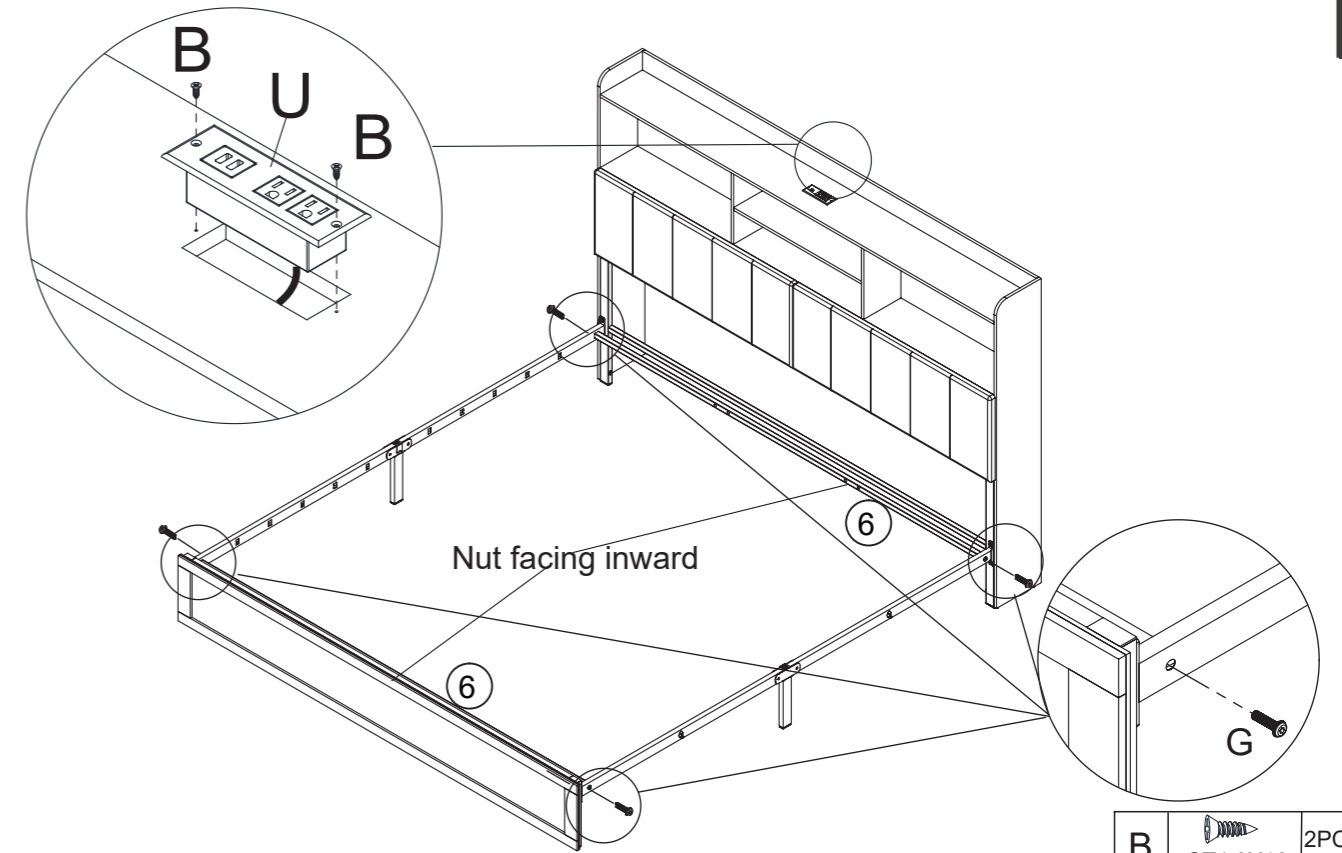

Note that the screws in this step can be locked properly!

B		ST4.2X12	2PCS
G		M8x40	4PCS

20

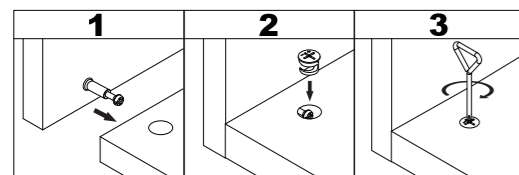
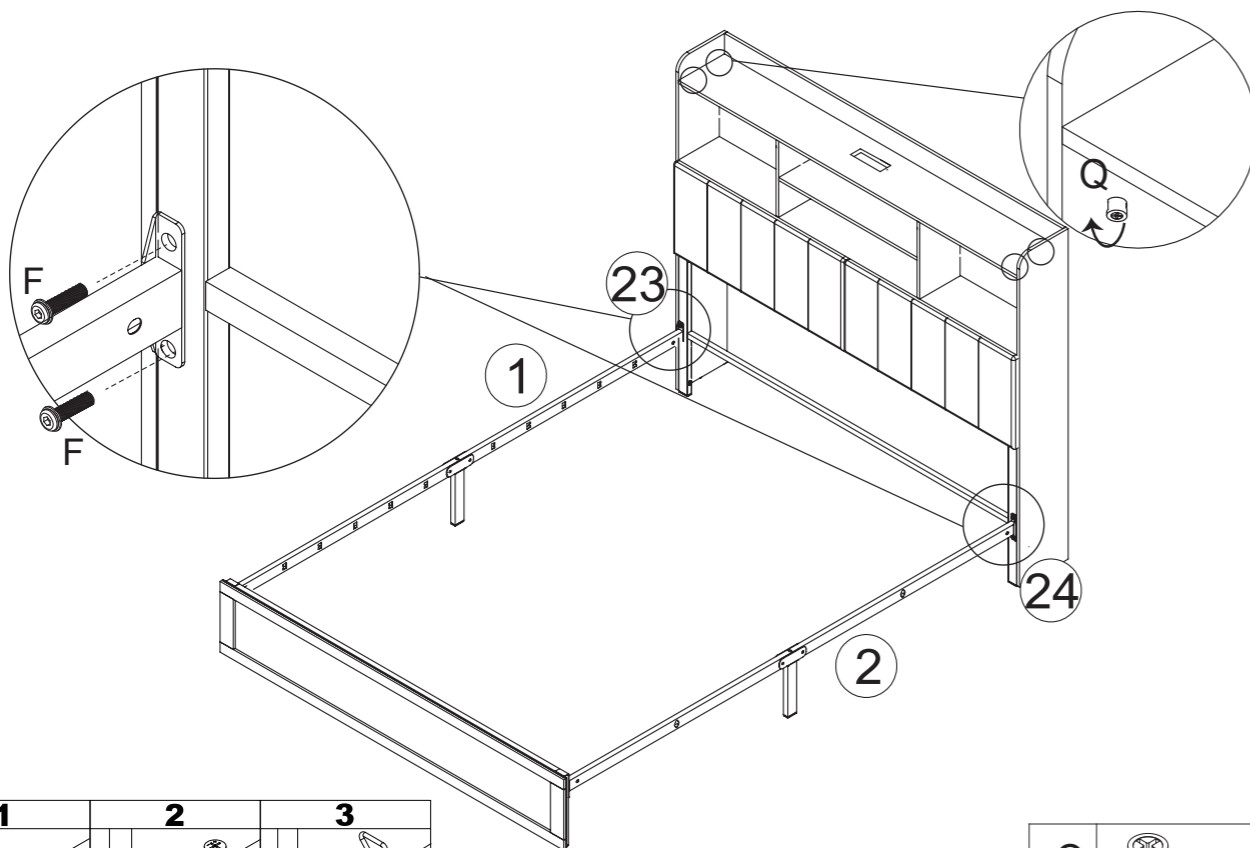

Q		φ15x9.5	4 pcs
F		M8x30	4PCS

22

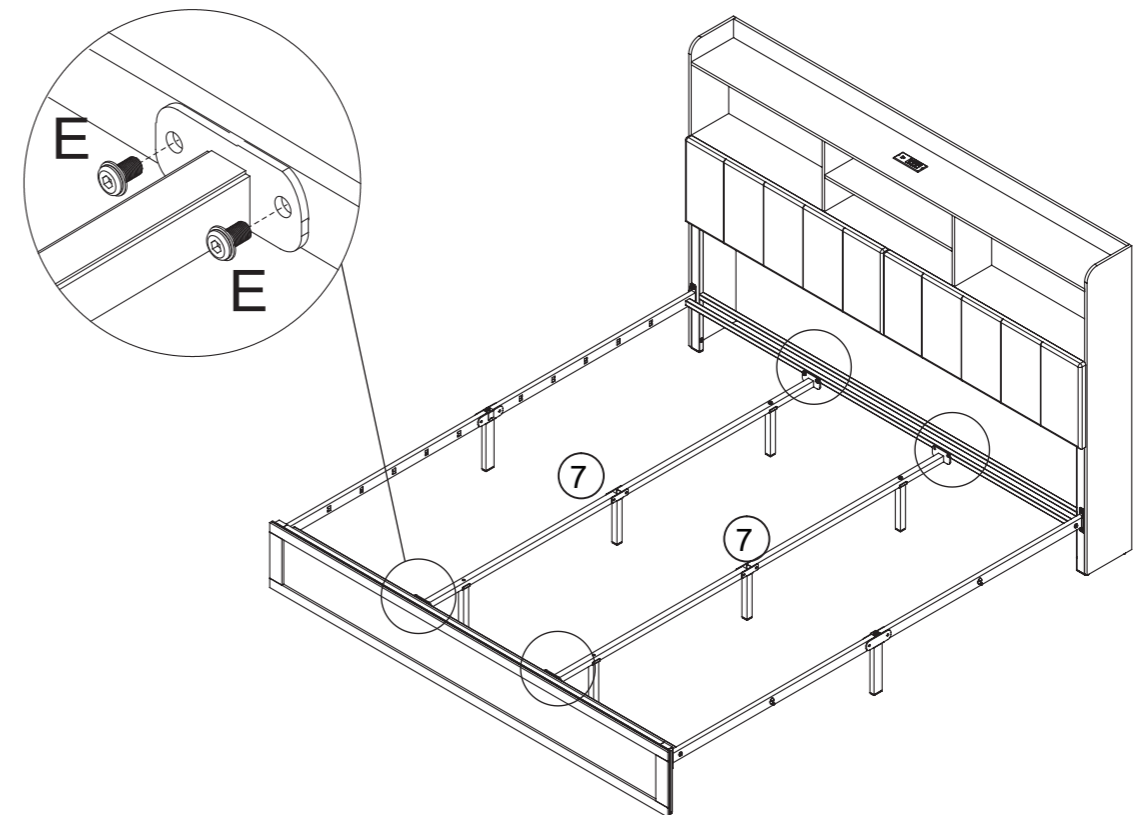

E		M8x18	8PCS
---	--	-------	------

# ASSEMBLY INSTRUCTIONS

23

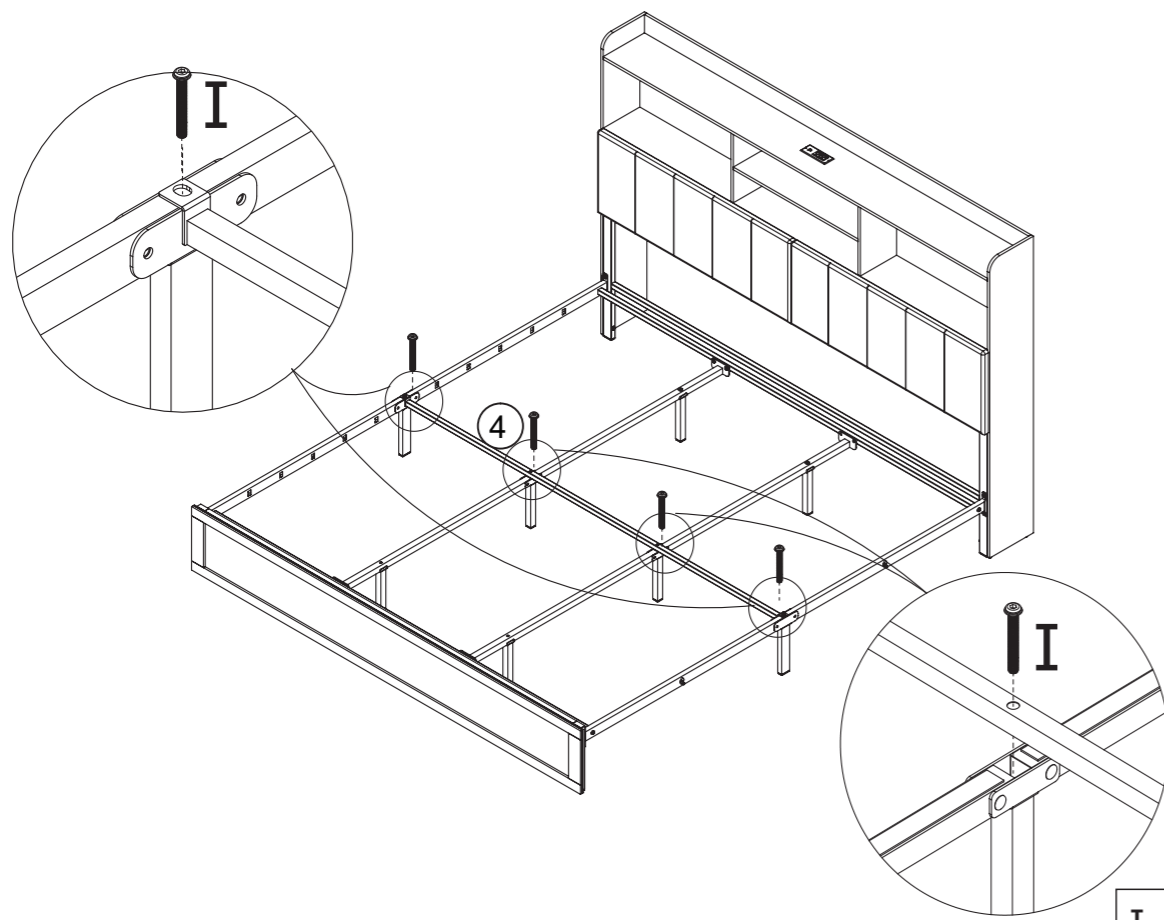

I M8x60 4PCS

# ASSEMBLY INSTRUCTIONS

X4 25

Open the metal frame

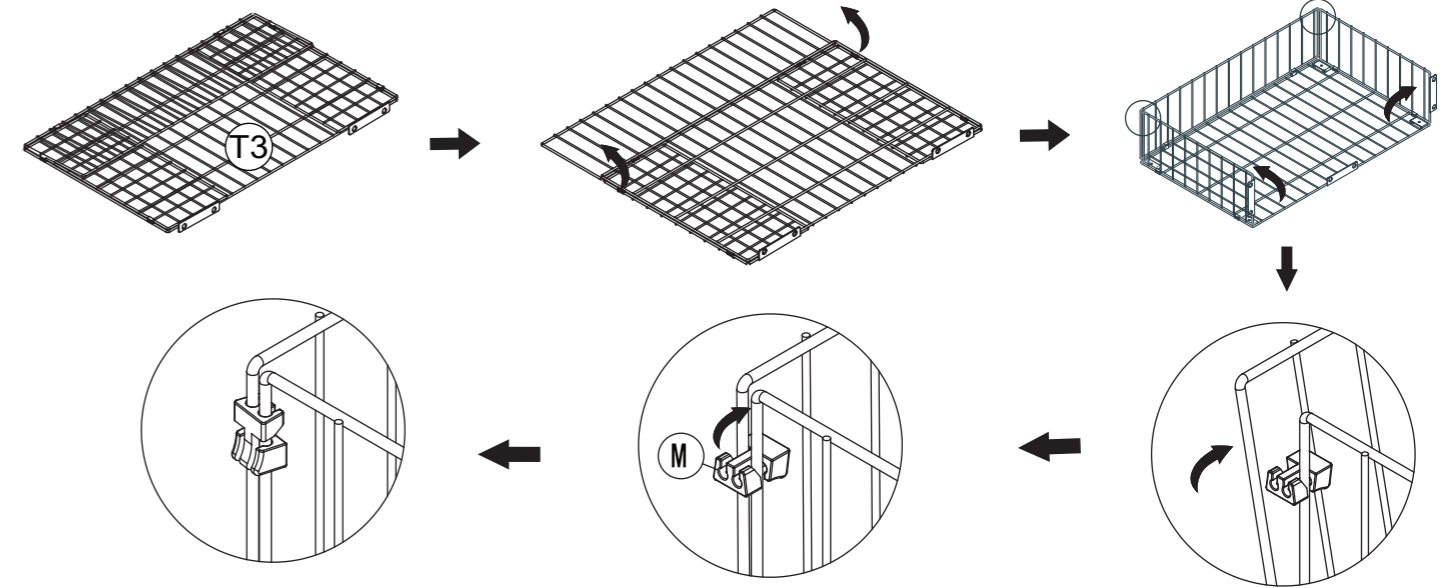

rotates part M at 90 degrees and lock the metal frame as shown on the graph

M 8PCS

24

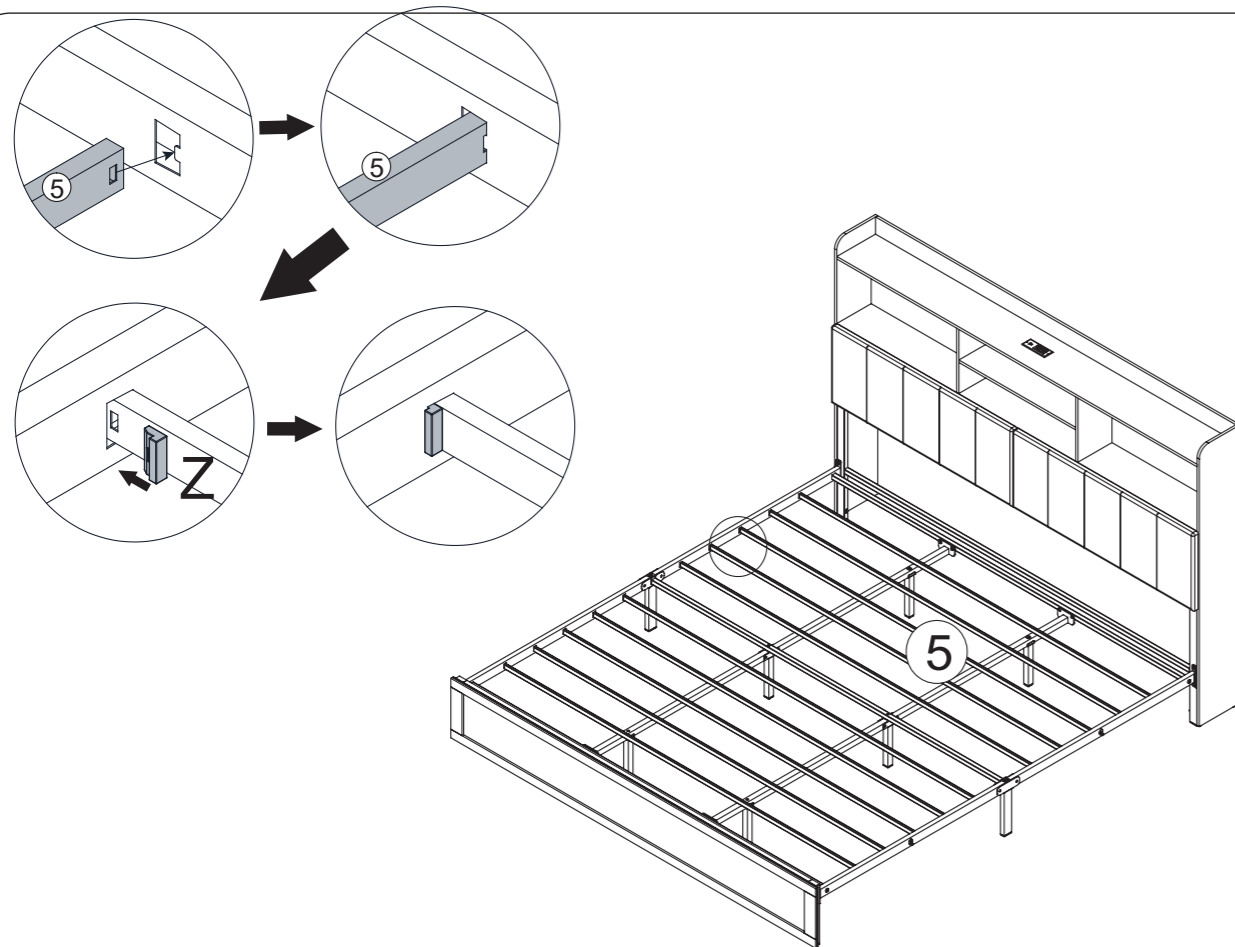

X4 26

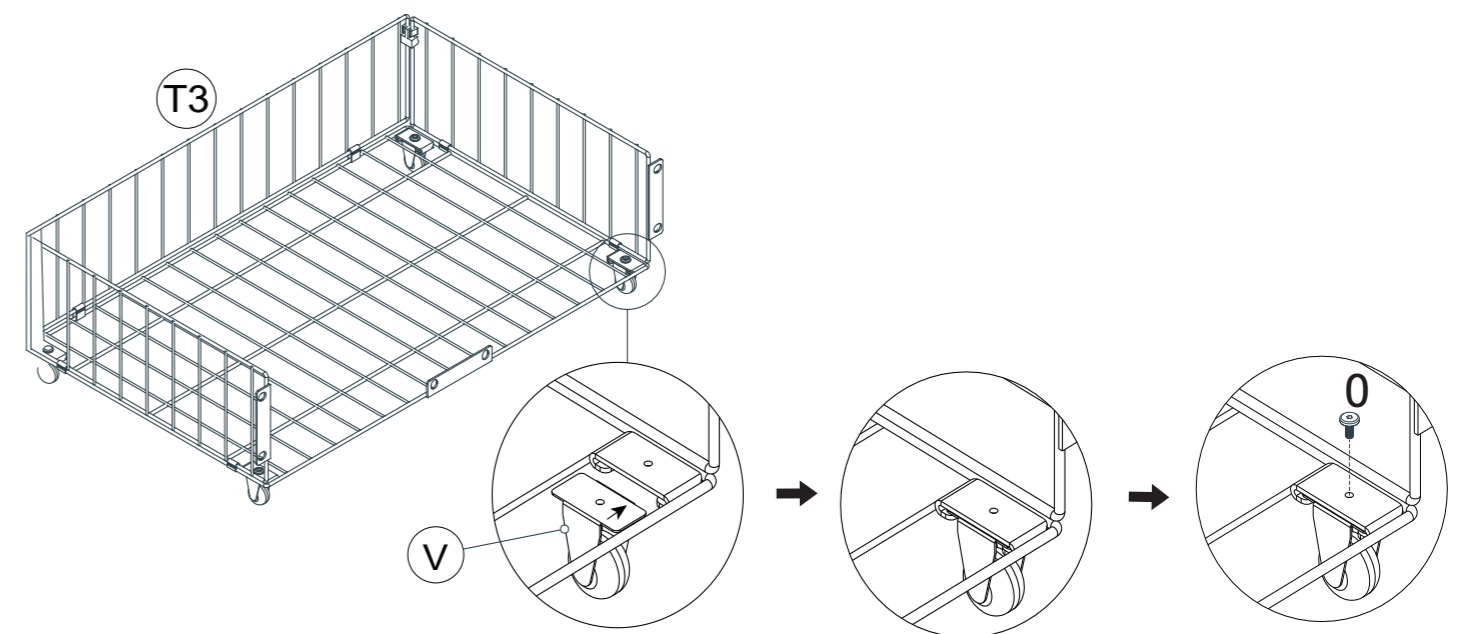

O M4x10 16PCS

X4 27

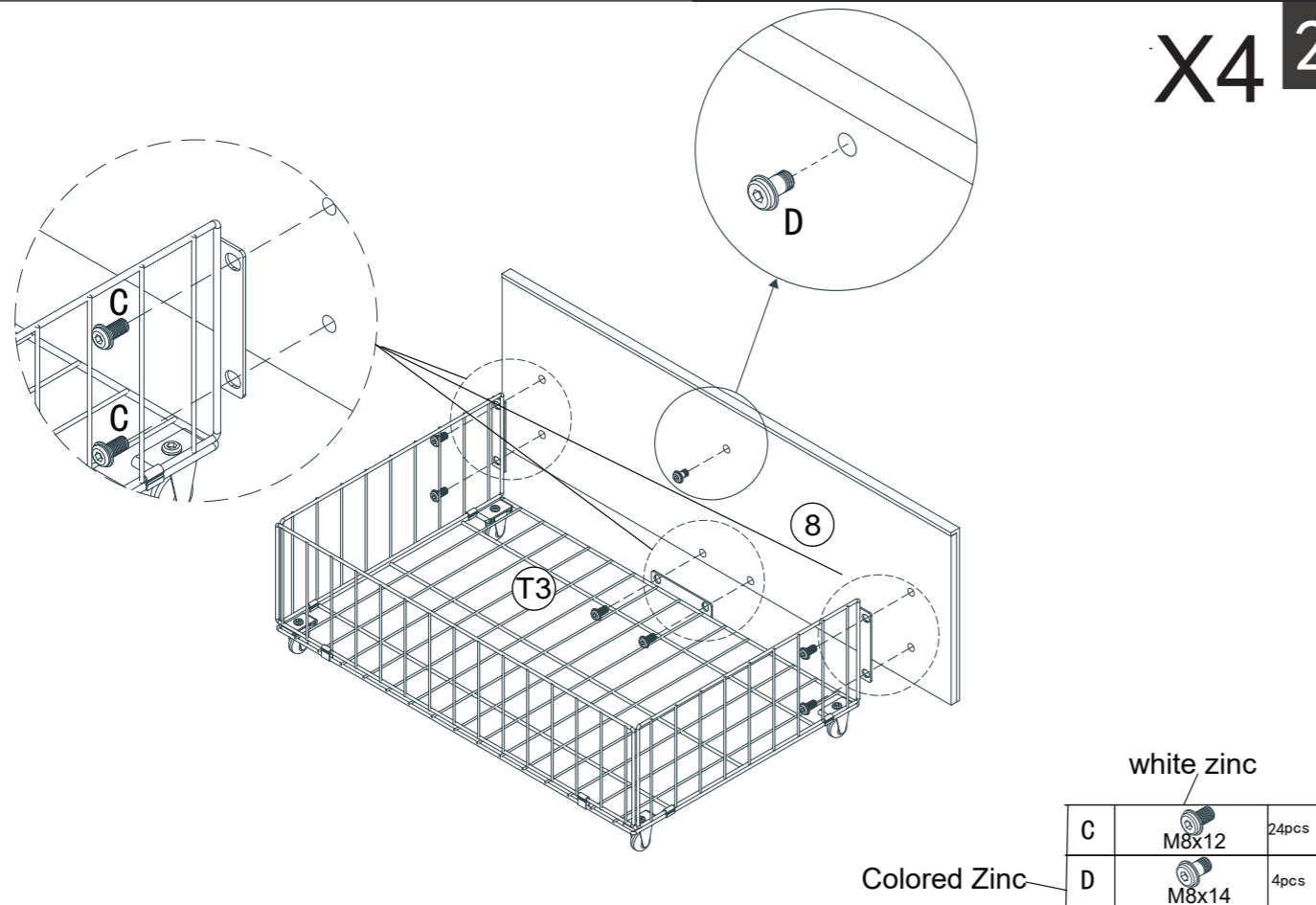

29

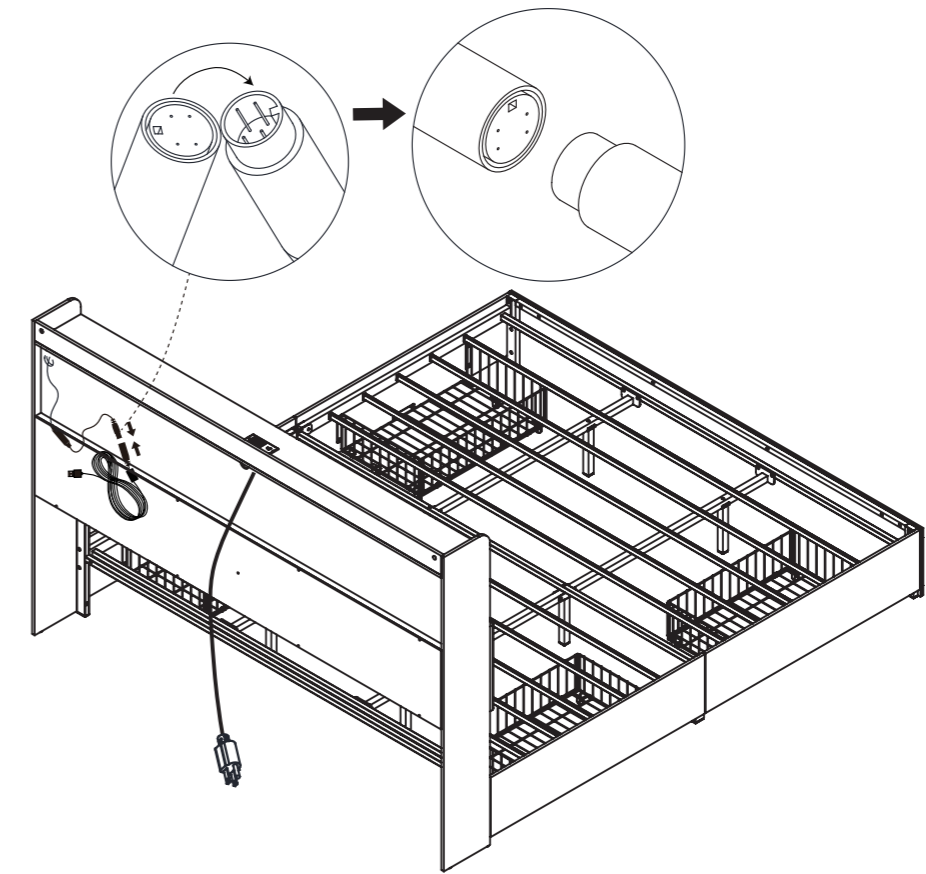

Gently lift the drawer, align the screw with the gourd-shaped hole, and then snap it in

28

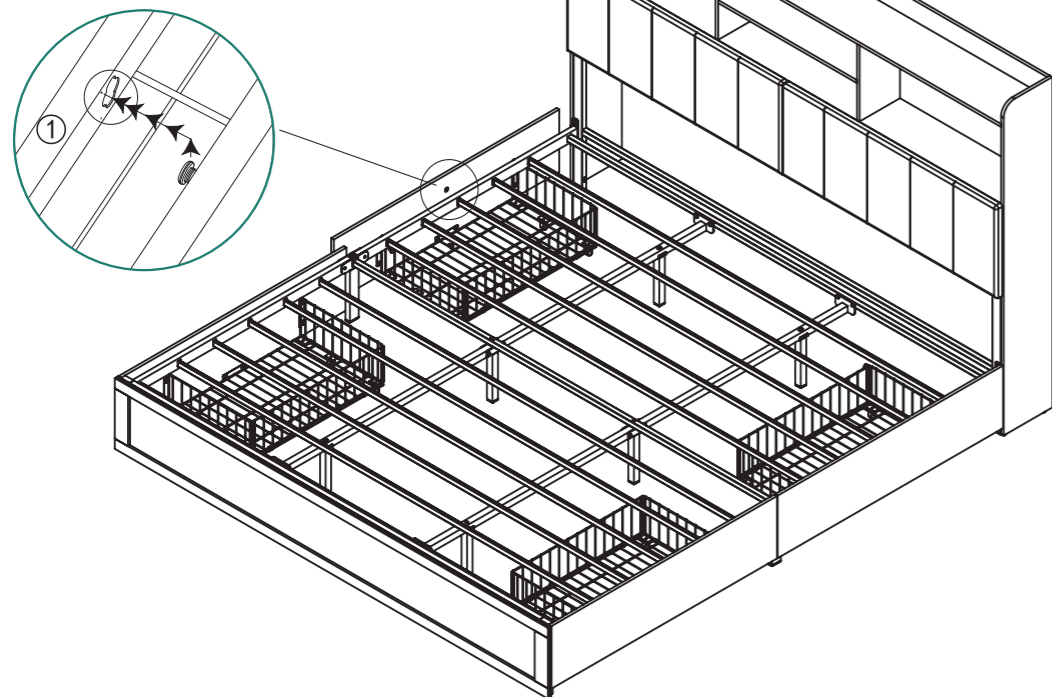

30

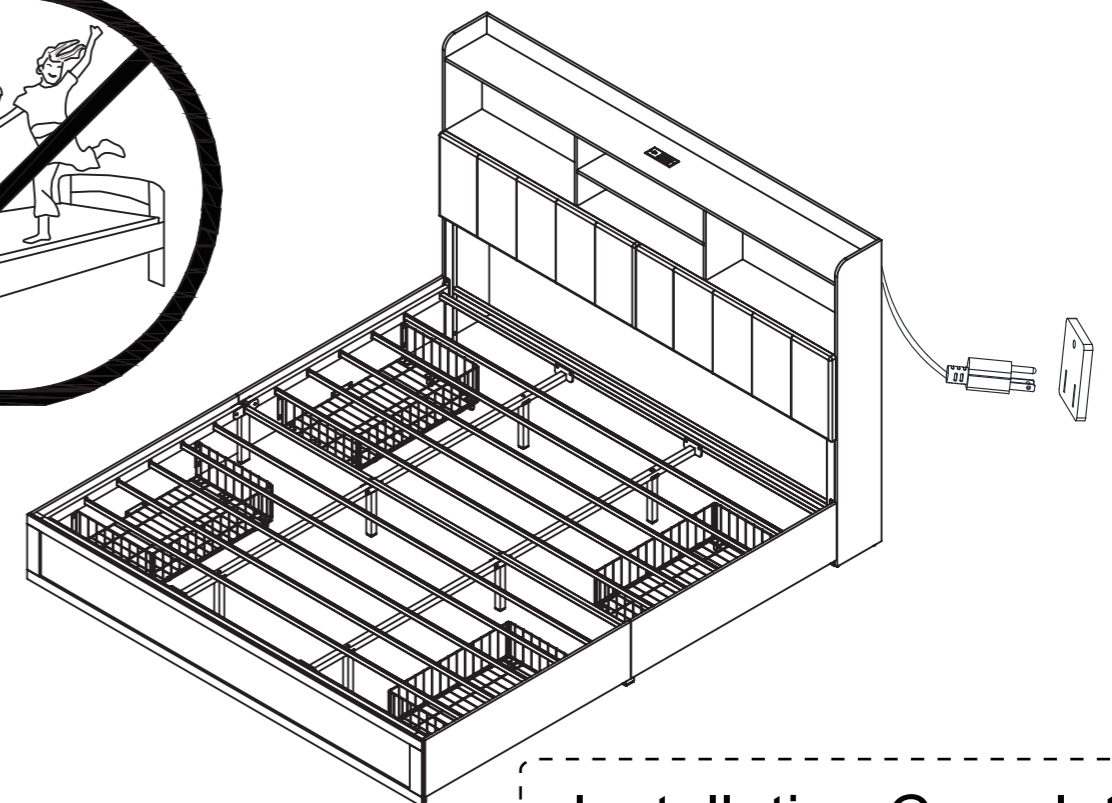

Installation Complete

