

ASSEMBLY INSTRUCTIONS

5 SHELF BOOKCASE

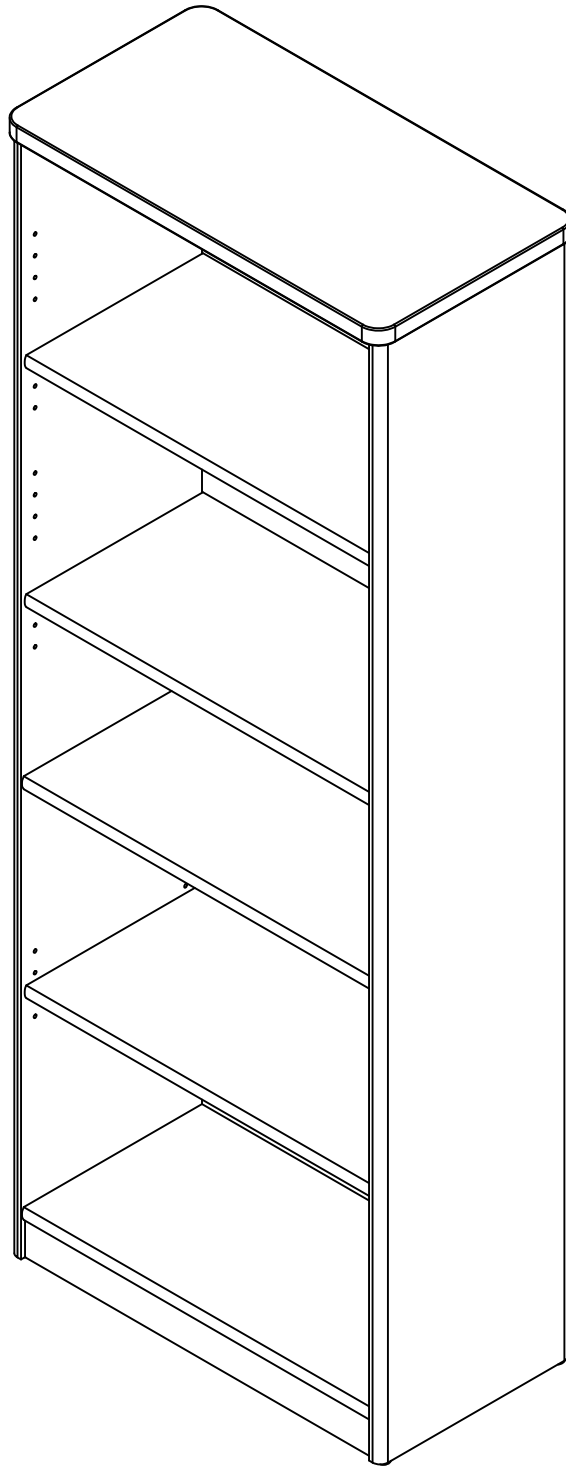

IMPORTANT SAFETY INFORMATION



WARNING

Serious or fatal crushing injuries can occur from furniture tip-over. To help prevent tip-over:

- Install tip-over restraint provided.
- Place heaviest items in the lower drawers or shelves.
- Unless specifically designed to accommodate, do not set TVs or other heavy objects on top of this product.
- Never allow children to climb or hang on drawers, doors or shelves.
- Never open more than one drawer at a time.
- Use of tip-over restraints may only reduce, but not eliminate, the risk of tip-over.

Remove items that might tempt kids to climb, such as toys and remote controls, from the top and upper shelves of the furniture.

Lesiones por aplastamiento graves o fatales pueden ocurrir desde muebles vuelco. Para ayudar a prevenir que vuelque:

- Instale que vuelque resistente proporcionado.
- Coloque los artículos más pesados en los cajones inferiores o estantes.
- A menos que específicamente diseñado para dar cabida, no establezca televisores u otros objetos pesados encima de este producto.
- Nunca permita que los niños se suban o se cuelguen de los cajones, puertas o estantes.
- Nunca abra más de un cajón a la vez.
- El uso de sistemas de retención de punta sobre sólo podrá reducir, pero no eliminar, el riesgo de vuelco.

Retire los elementos que puedan tentar a los niños a subir, como juguetes y mandos a distancia, desde los estantes superiores y superiores de los muebles.

Des blessures par écrasement graves ou mortelles peuvent se produire des meubles renversement. Pour aider à prévenir un renversement:

- Installez sur la pointe résistant fourni.
- Placez les articles les plus lourds dans les tiroirs inférieurs ou des étagères.
- Sauf spécifiquement conçu pour accueillir, ne réglez pas les téléviseurs ou d'autres objets lourds sur ce produit.
- Ne jamais laisser les enfants grimper ou de se pendre tiroirs, portes ou des étagères.
- Ne jamais ouvrir plus d'un tiroir à la fois.
- Utilisation de la contention de renversement ne peut réduire, mais non éliminer, le risque de renversement.

Retirez les articles qui pourraient tenter les enfants de grimper, tels que les jouets et les télécommandes, des étagères supérieure et supérieure des meubles.



WARNING

Do not load unit without properly attaching back panel. Doing so could cause instability, product collapse, and/or serious injury.

No cargue esta unidad sin el panel de atrás. Hacerlo puede causar inestabilidad, que el producto se derrumbe, y/o heridas (golpes) serias.

Ne pas charger le produit sans attacher correctement le panneau arrière. Faire ainsi peut causer l'instabilité ou l'effondrement du produit et peut vous causer des endommagements sérieux.



WARNING

Do not move unit when loaded. Doing so could cause instability, product collapse, tip over, and/or serious injury.

No mueva la unidad cuando esté cargada. Hacerlo puede causar inestabilidad, que el producto se derrumbe, que se la caiga encima y/o heridas (golpes) serias.

Ne pas déplacer l'unité lorsqu'elle est chargée. Faire ainsi peut causer l'instabilité, l'effondrement ou le renversement du meuble et/ou des endommagements sérieux.

EXPLODED VIEW

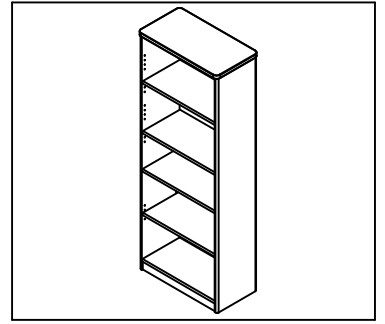
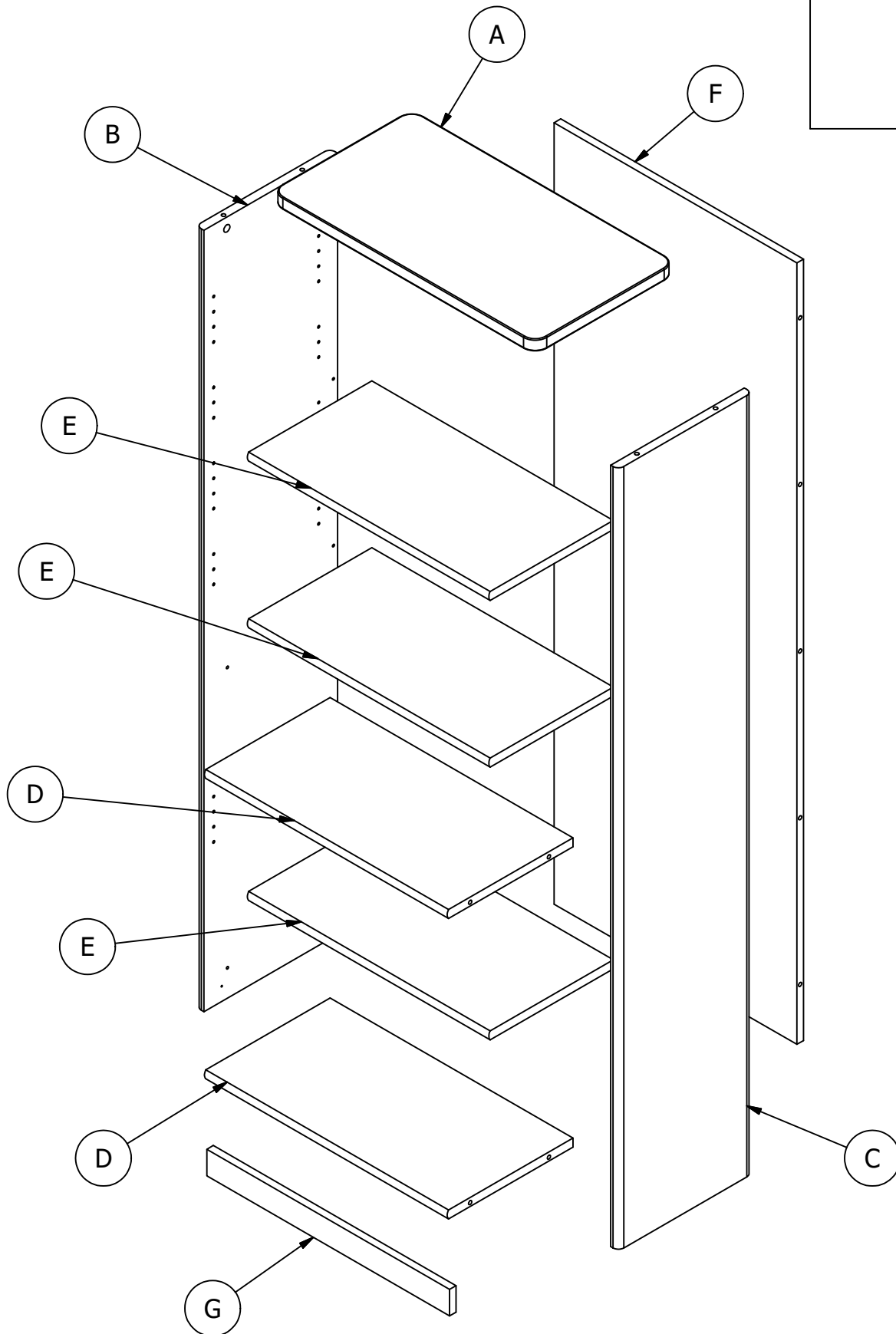

PARTS LIST

WC14365

A [1] W89207
B [1] W100739
C [1] W100740
D [2] W100741
E [3] W100742
F [1] W100743
G [1] W100744

WC14565

A [1] W88890
B [1] W88891
C [1] W88892
D [2] W88893
E [3] W88894
F [1] W88895
G [1] W88896

WC25565

A [1] W151027
B [1] W150939
C [1] W150940
D [2] W150941
E [3] W150942
F [1] W150943
G [1] W150944

WC57465

A [1] W100738
B [1] W100739
C [1] W100740
D [2] W100741
E [3] W100742
F [1] W100743
G [1] W100744

WC64365

A [1] W128428
B [1] W128429
C [1] W128430
D [2] W128431
E [3] W128432
F [1] W128433
G [1] W128434

WC84865

A [1] W105145
B [1] W100739
C [1] W100740
D [2] W100741
E [3] W100742
F [1] W100743
G [1] W100744

WC94465

A [1] W100746
B [1] W100747
C [1] W100748
D [2] W100749
E [3] W100750
F [1] W100751
G [1] W100752

FASTENERS / HARDWARE

Fasteners are shown in actual size.
los fijadores son demostrados en su tamaño actual.
les attaches sont montrées dans l'échelle grandeur.

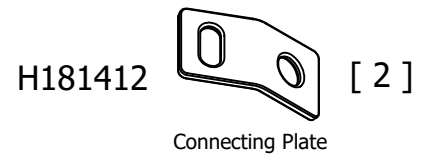
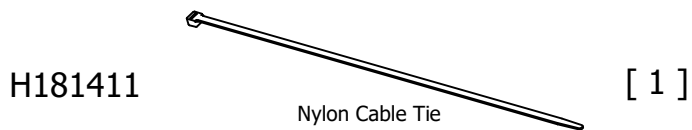
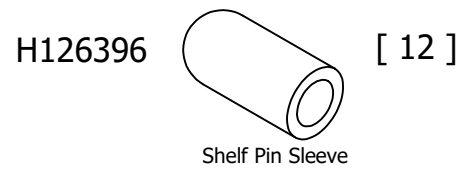
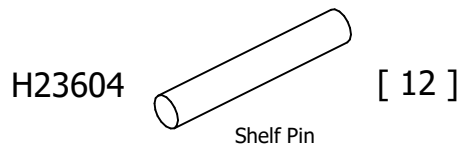
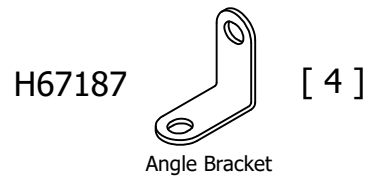
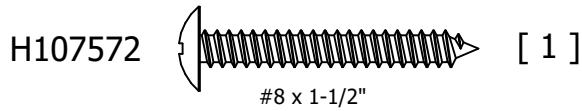
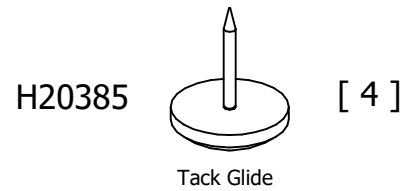
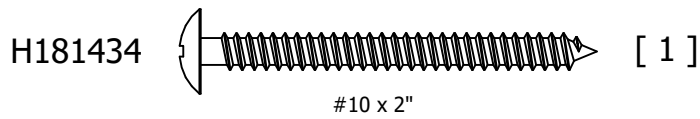
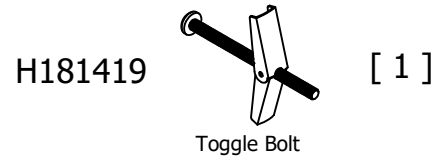
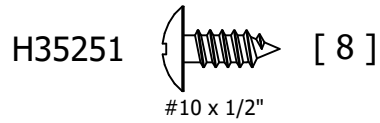
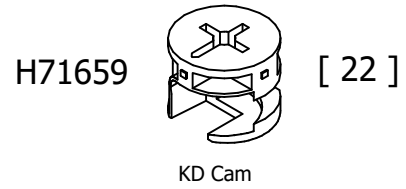
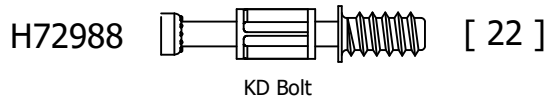

WC14365, WC57465, WC84865

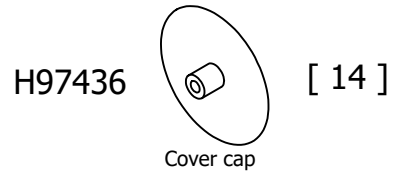

WC25565, WC94465

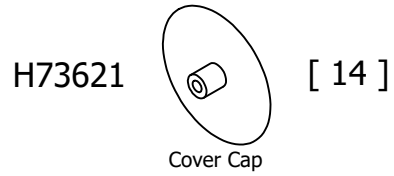

WC14565, WC64365

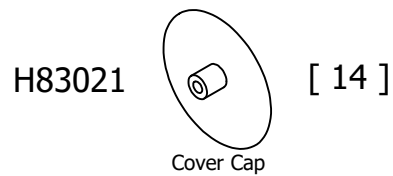

ATTENTION

Common assembly techniques.
Técnica común de ensamblaje.
Techniques communes d'assemblage.

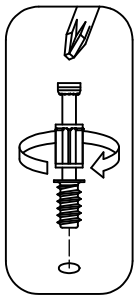

- Use a screwdriver with H72988.
- Favor de usar un desarmador con el tornillo H72988.
- Utilisez un tournevis avec H72988.

- Wood dowel installation.
- Instalación del tornillo de madera.
- Installation de chevilles de bois.

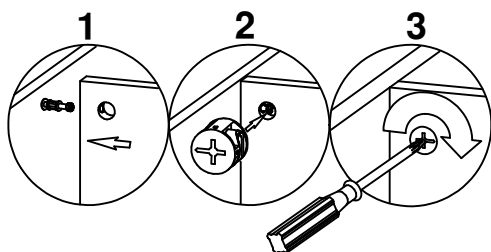
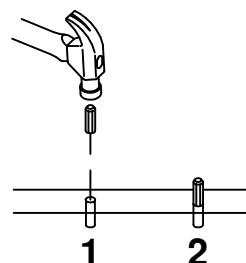

- Panel to panel attachment.
- Fijación de tablero con tablero.
- Fixation d'un panneau à l'autre

- Wood dowel installation with glue.
- Instalación del tornillo de madera con pegamento.
- Installation de chevilles de bois avec la colle.

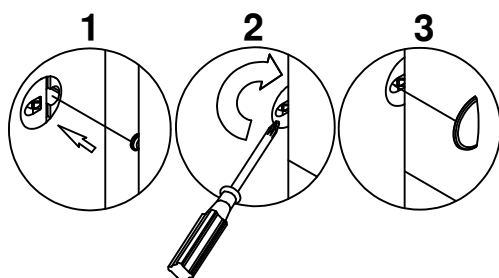
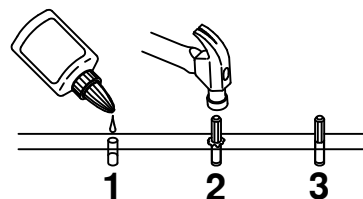

- Panel to panel attachment.
- Fijación de tablero con tablero.
- Fixation d'un panneau à l'autre

STEP 1

H72988

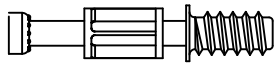

[18]

KD Bolt

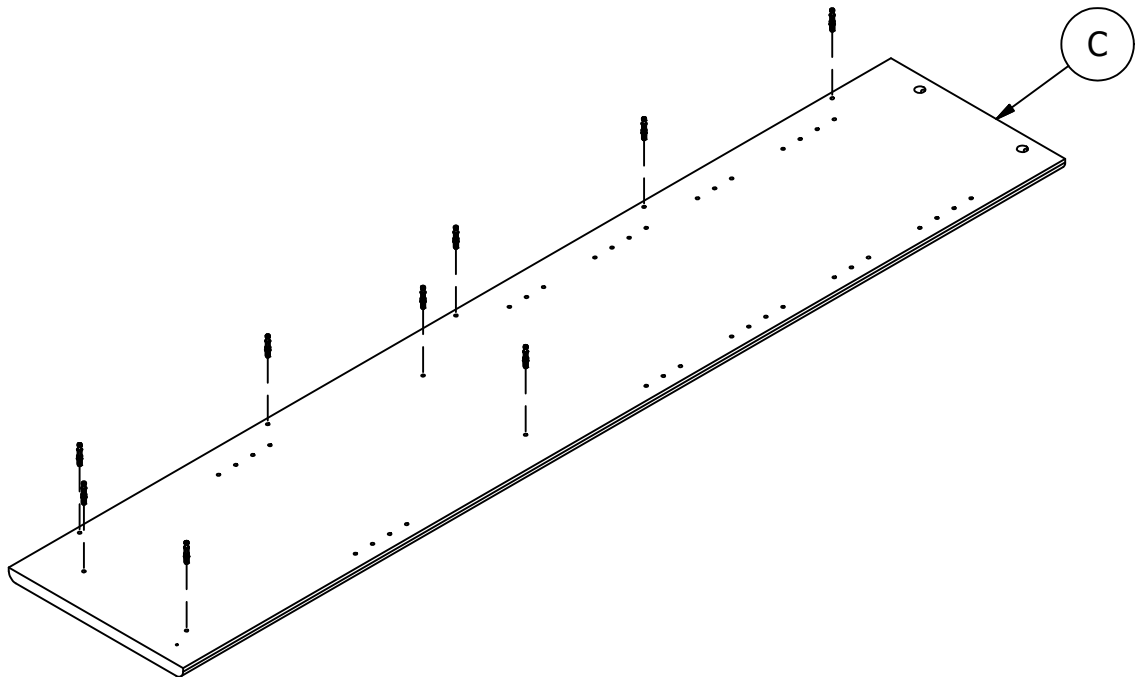
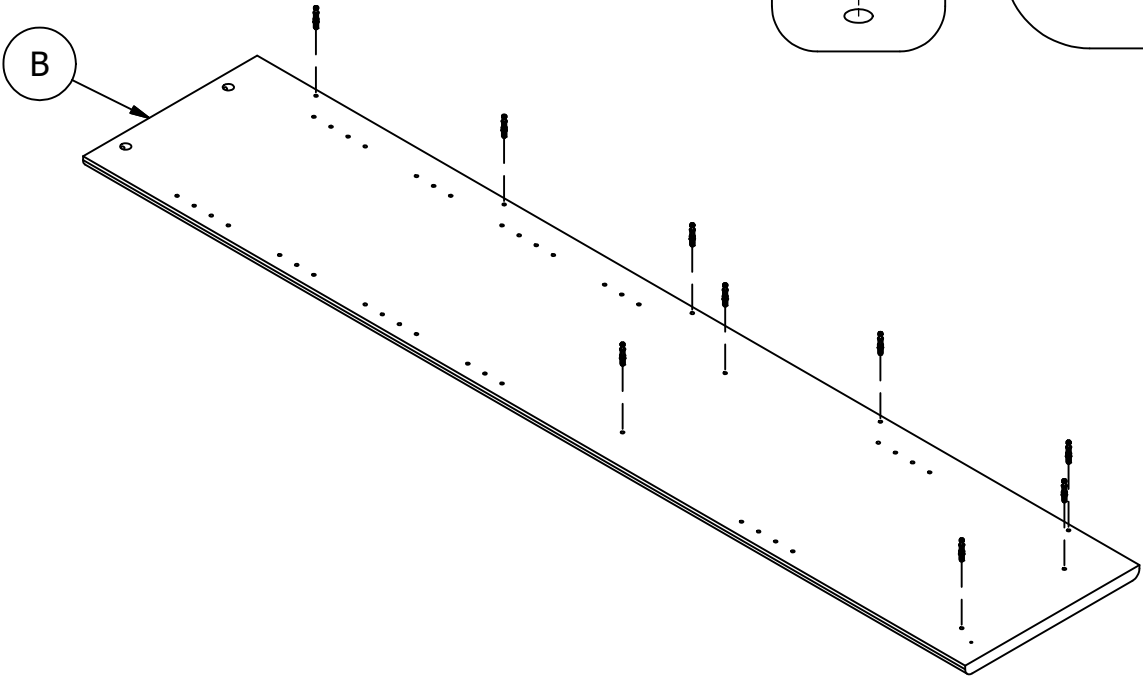
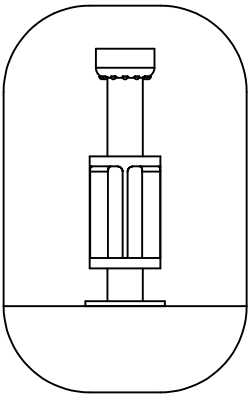
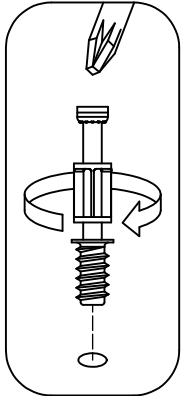

STEP 2

H71659

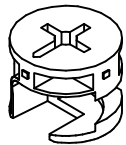

[5]

KD Cam

COVER CAP

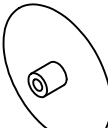

[5]

Cover cap

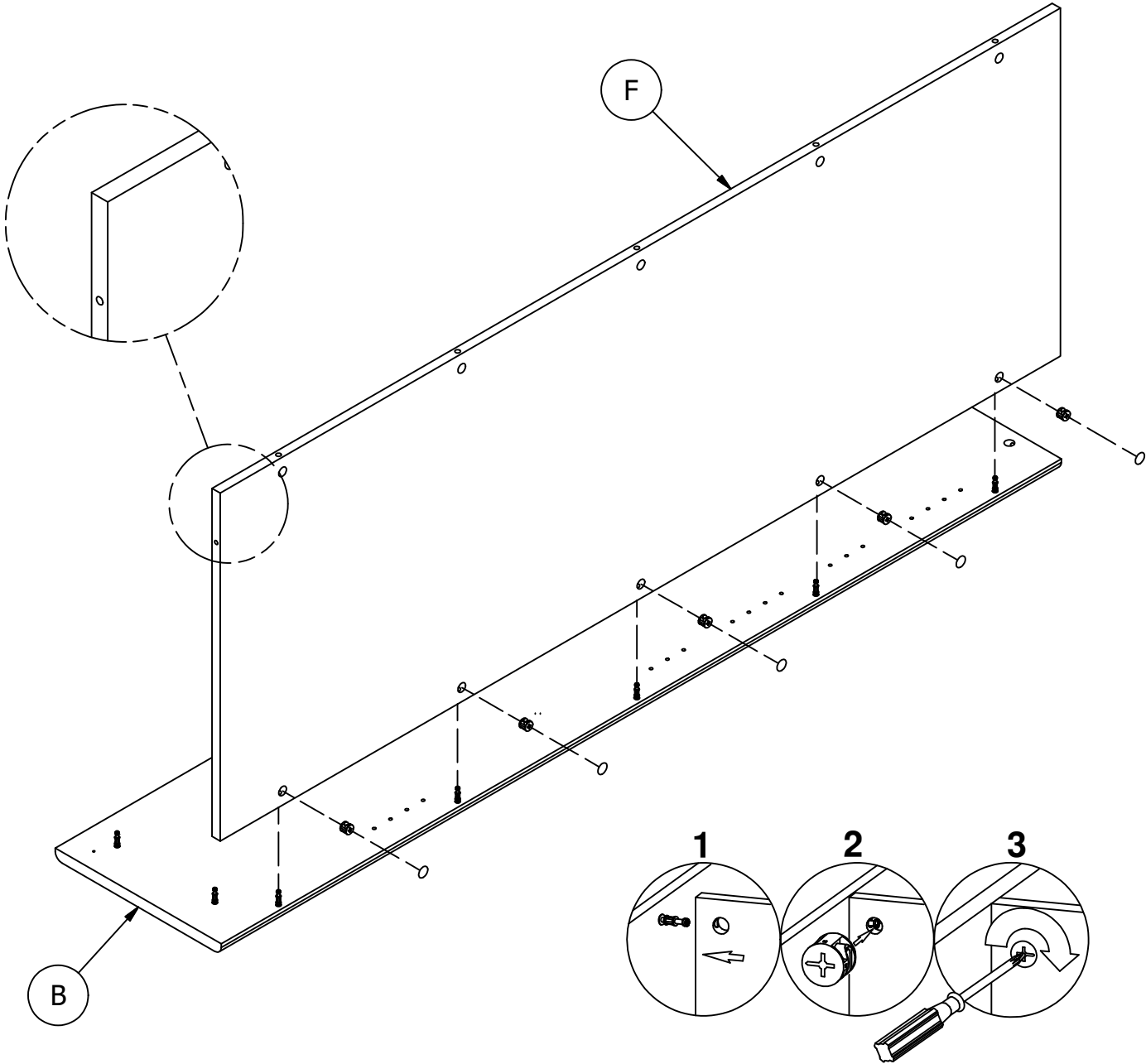

STEP 3

H71659

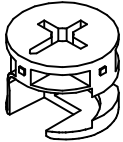

KD Cam

[4]

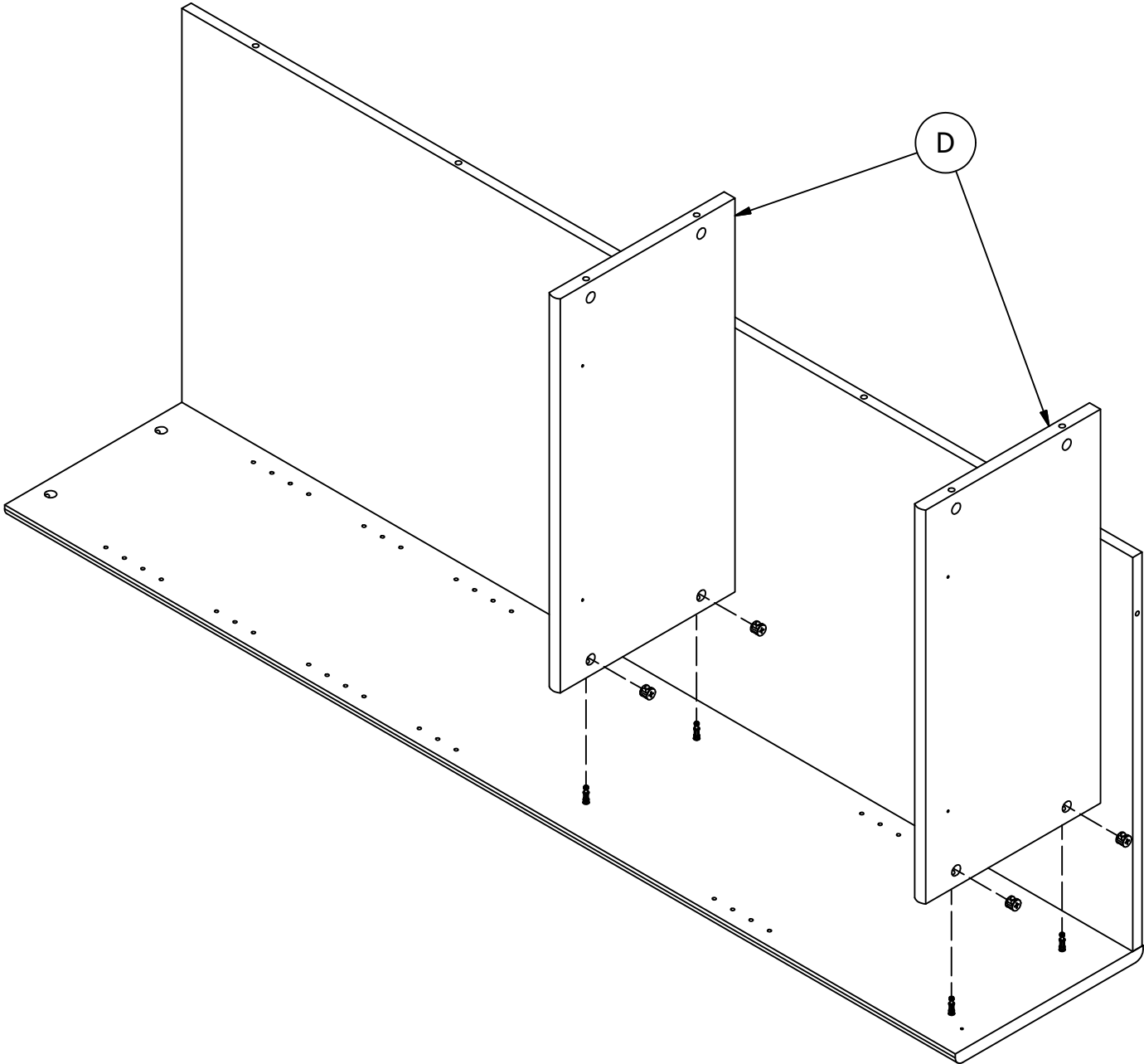
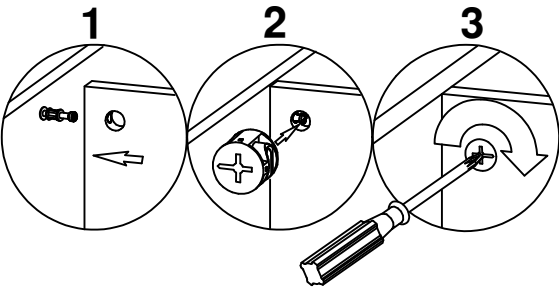

STEP 4

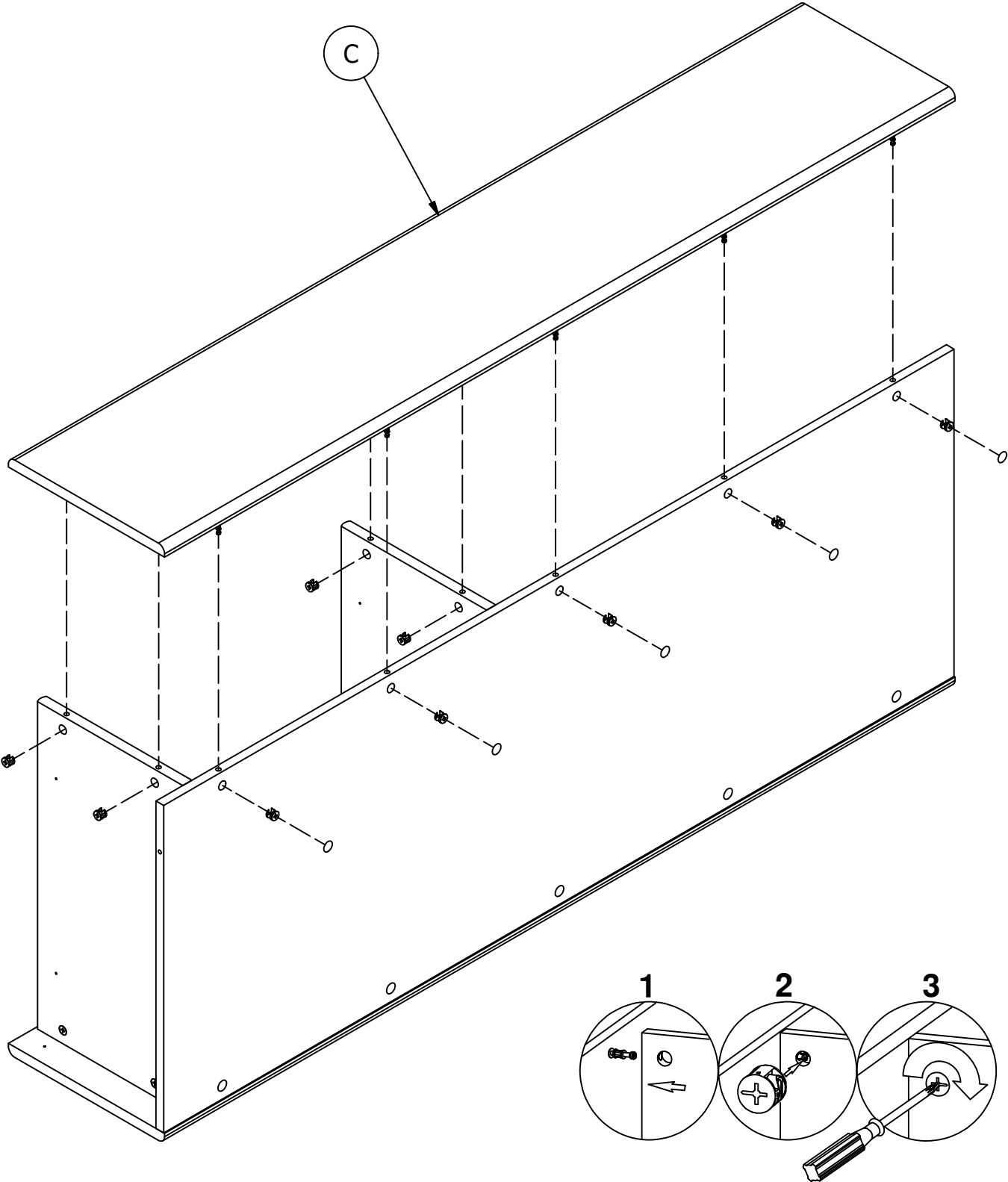
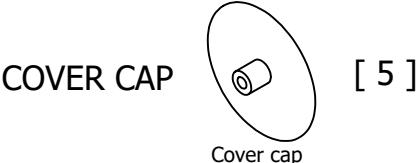

STEP 5

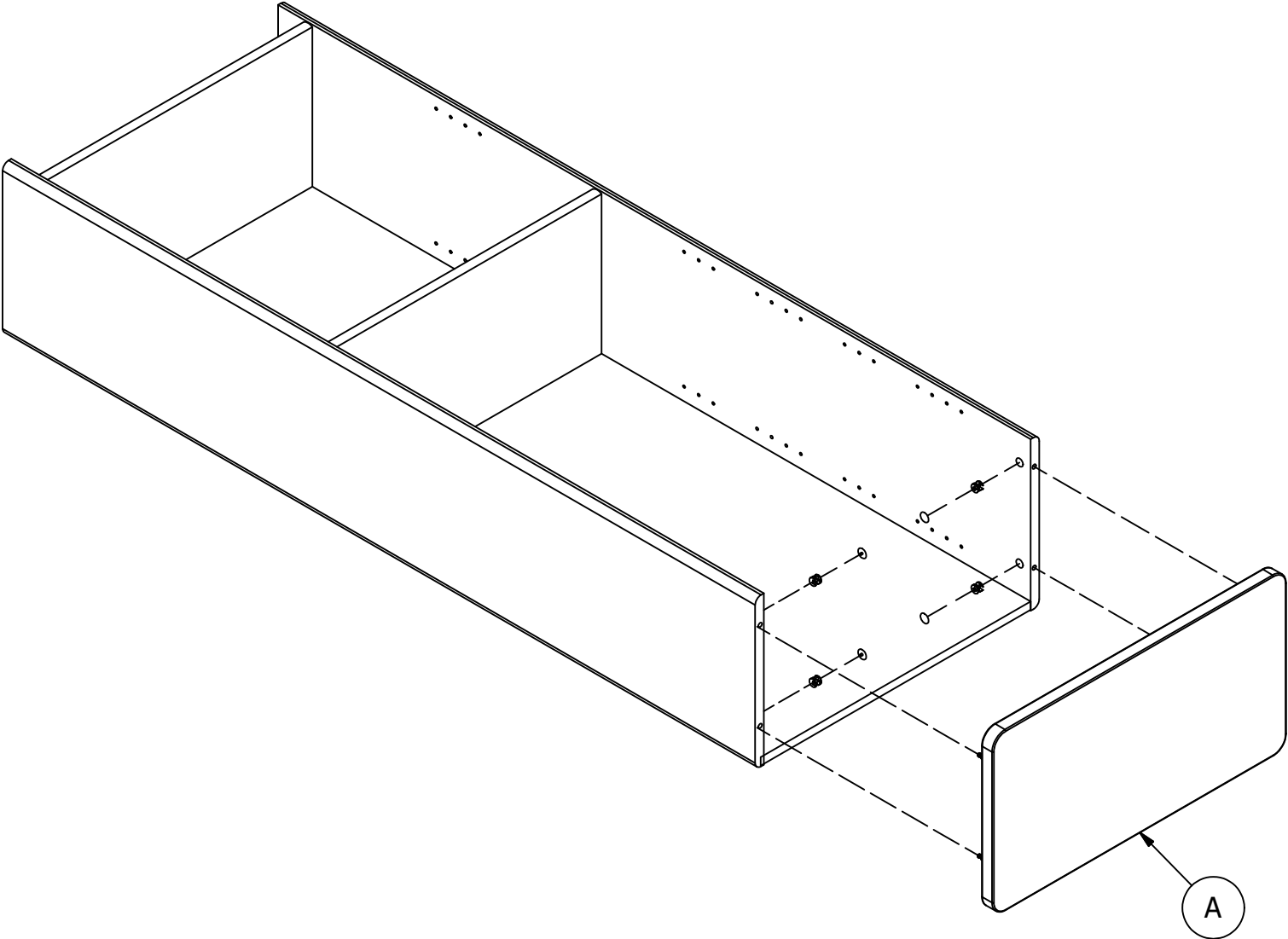
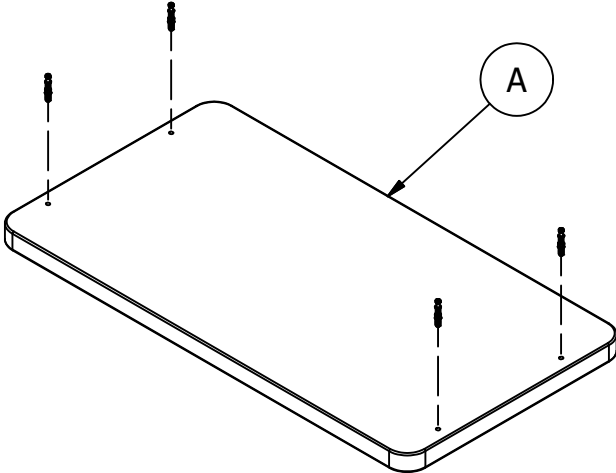
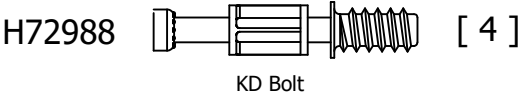
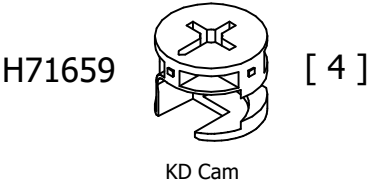

STEP 6

H67187 [4]
Angle Bracket

H35251 [8]
#10 x 1/2"

H20385 [4]
Tack Glide

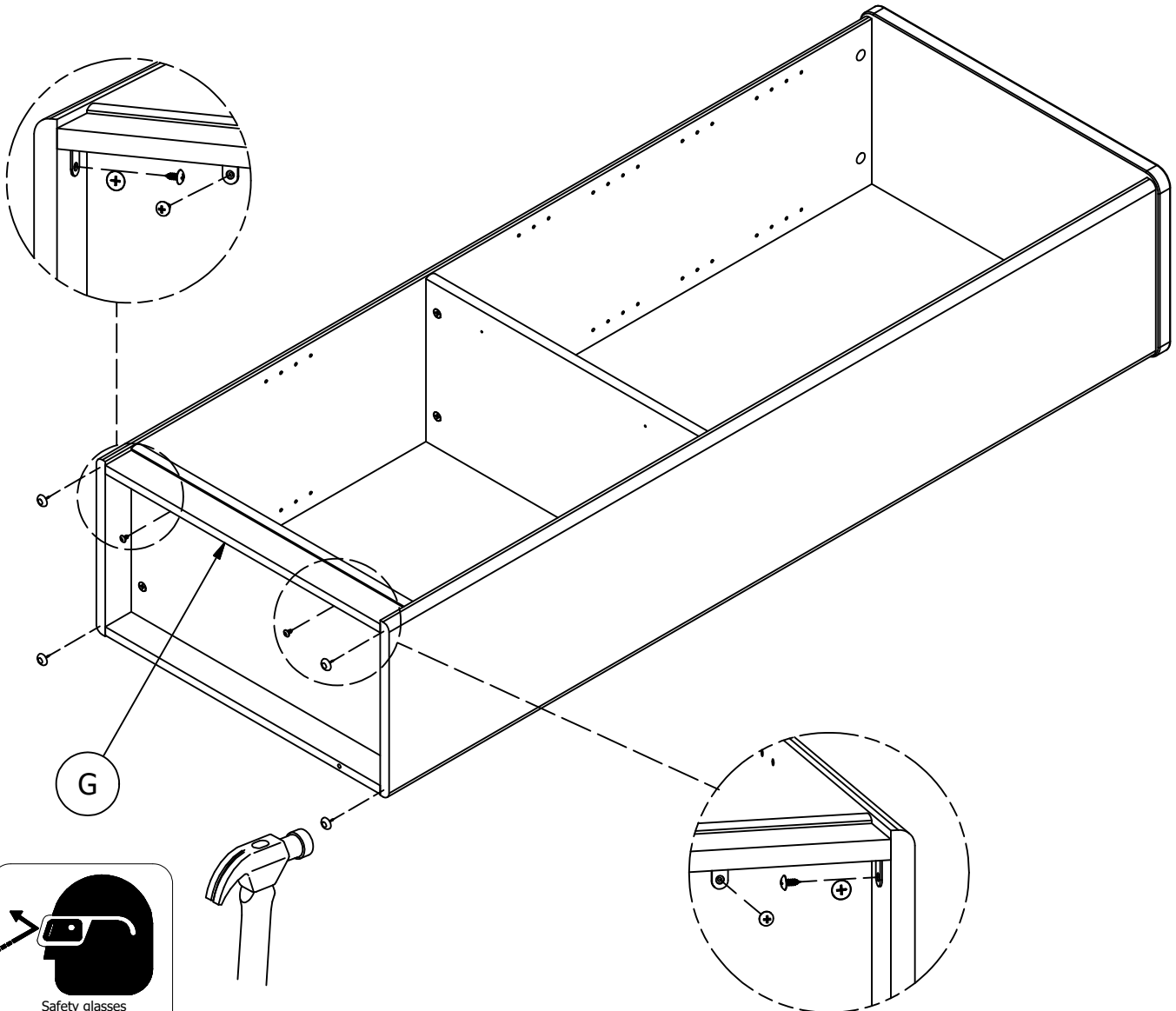
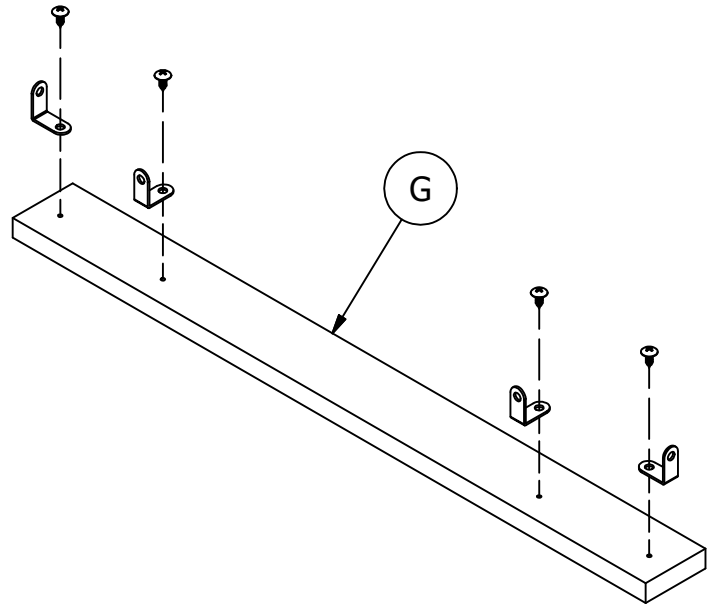

STEP 7

Secure unit to the wall with a tip-over restraint.

Unidad de seguro a la pared con un sistema de retención de un vuelco.

Fixer l'unité au mur avec un dispositif de retenue renversement.

1. Place unit in desired location.
2. Locate wall stud nearest unit center. **FIG A**
3. On wall, mark center of stud location 1" below top of unit. **FIG A**
4. If a wall stud cannot be located mark hollow wall at unit center. **FIG A**
5. On back of unit, mark corresponding location 3/8" below top of unit. **FIG B**

1. Coloque la unidad en el lugar deseado.
2. Localice pie derecho de pared centro de unidad más próxima.
3. En la pared del, marque el centro de la ubicación del montante 1 "abajo la parte superior de la unidad.
4. Si un poste de la pared no se puede localizar marcar pared hueca en el centro de la unidad.
5. En el dorso de la unidad, marque la ubicación 3/8 correspondiente abajo la parte superior de la unidad.

1. Placez l'unité à l'endroit désiré.
2. Localiser centre d'unité la plus proche de la paroi Stud.
3. Sur le mur, centre de emplacement du montant 1 "ci-dessous dessus de l'appareil de la marque.
4. Si un montant de mur ne peut pas être situé marquer mur creux au centre de l'unité.
5. Le dos de l'appareil, marquer l'emplacement 3/8 correspondant ci-dessous dessus de l'appareil.

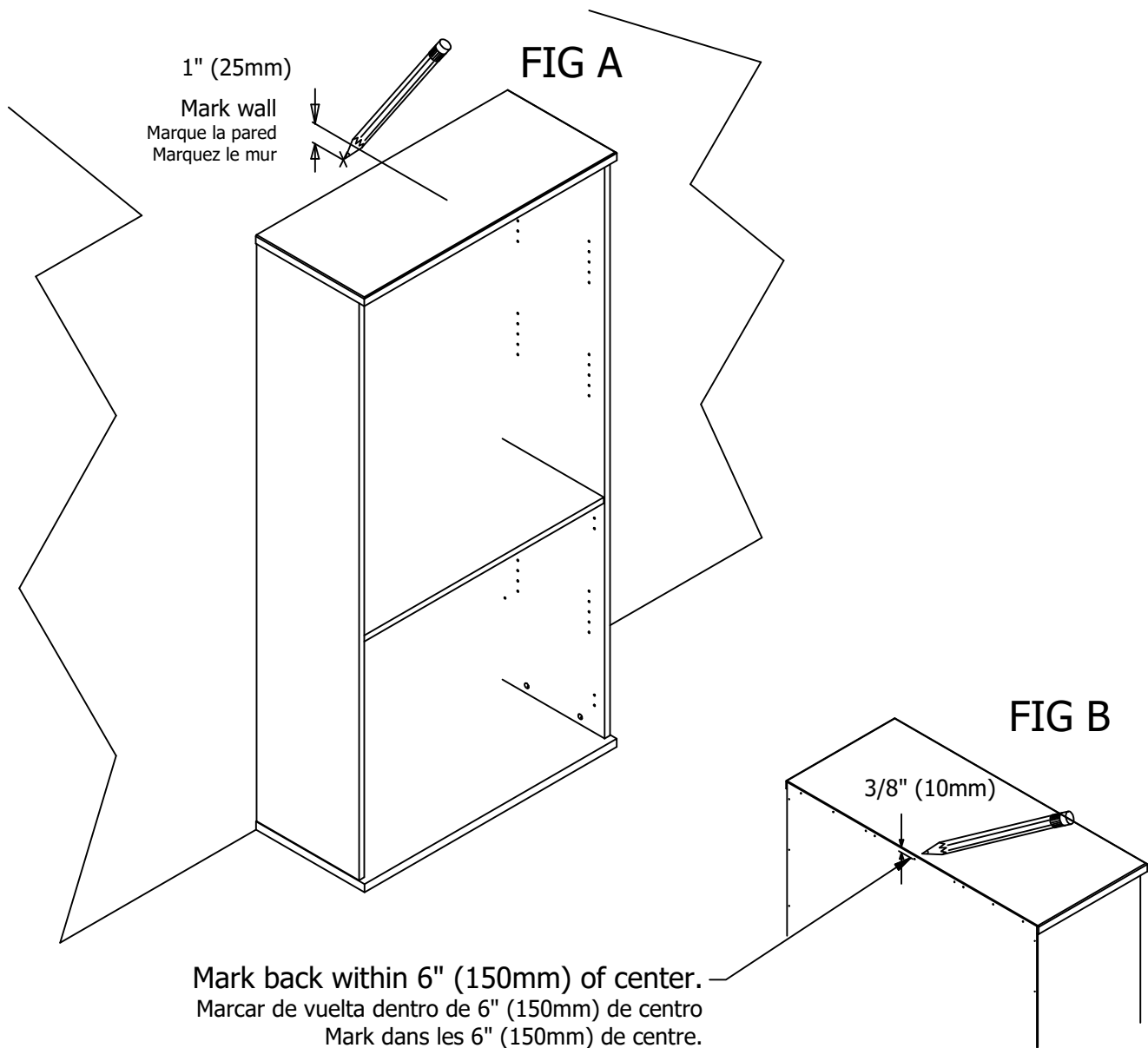

WALL STUD ATTACHMENT

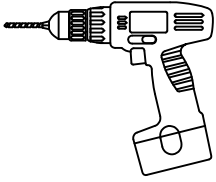

Drill 1/8" hole 2" deep at mark on wall.
 Taladro 1/8 "agujero 2" de profundidad en la marca en la pared.
 Percer 1/8 "trou de 2" de profondeur à la marque sur le mur.

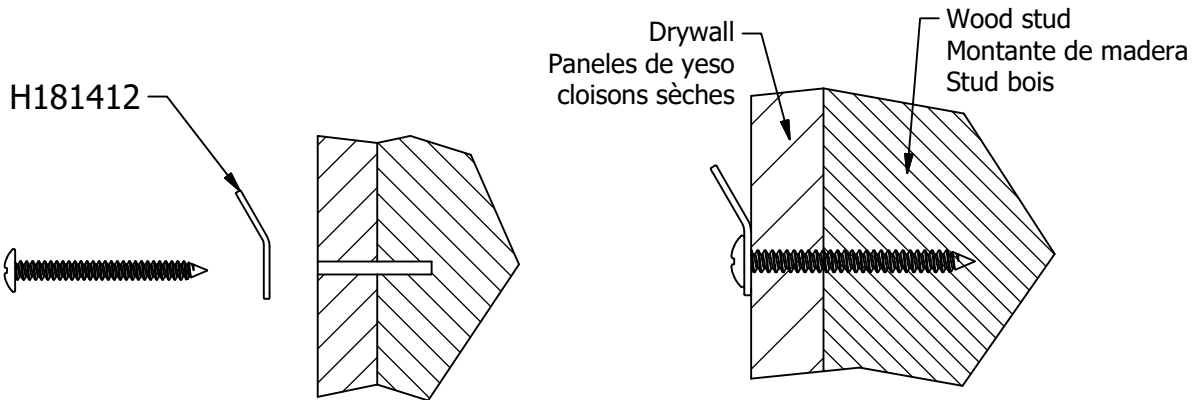
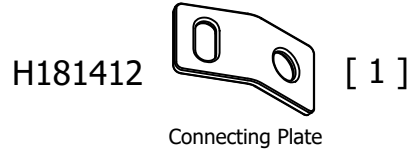
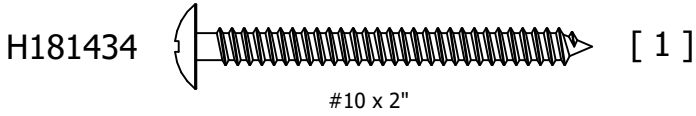

HOLLOW WALL ATTACHMENT

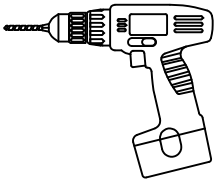

Drill 1/2" hole 1" deep at mark on wall.
 Taladro 1/2 "agujero 1" de profundidad en la marca en la pared.
 Percer 1/2 "trou de 1" de profondeur à la marque sur le mur.

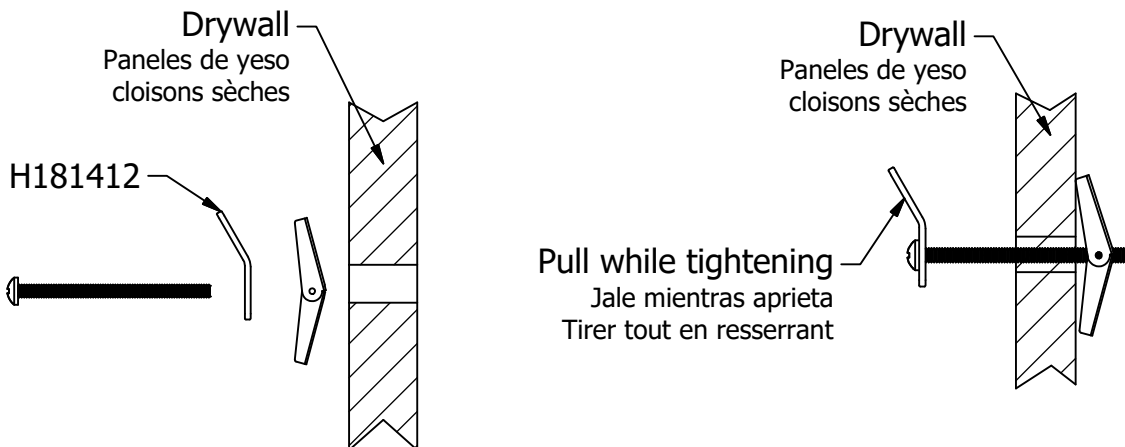
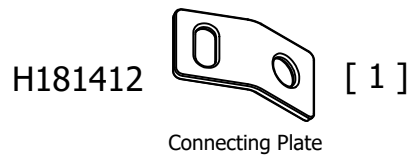
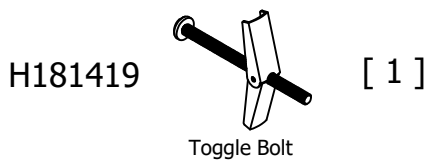

STEP 9

H107572

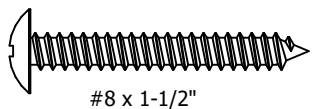

[1]

H181412

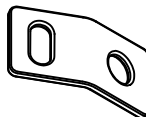

[1]

Connecting Plate

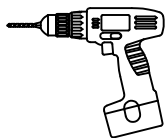

Drill 1/8" hole 1" deep at mark on unit.

Taladro 1/8 "agujero de 1" de profundidad en la marca de la unidad.

Perçer 1/8 "trou 1" de profondeur à la marque sur l'unité.

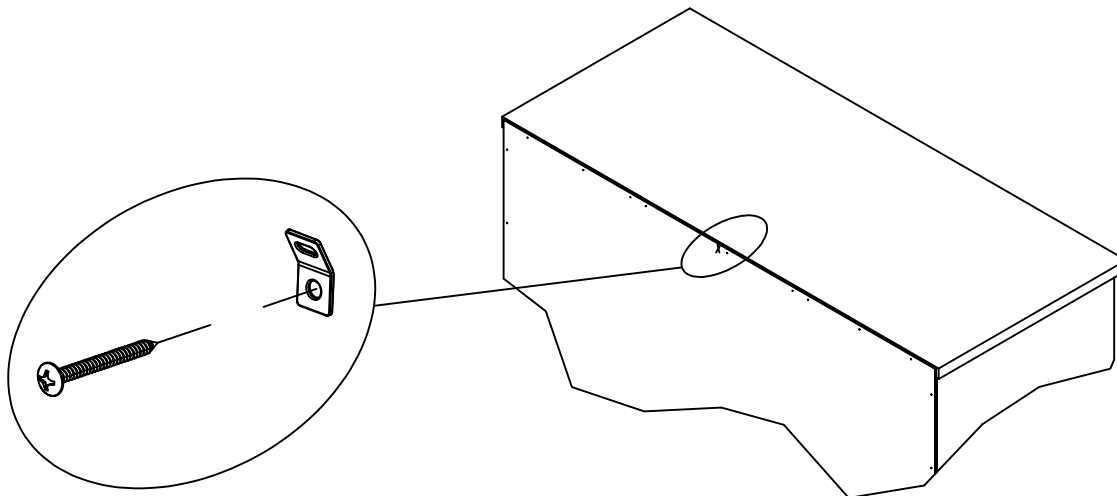

H181411

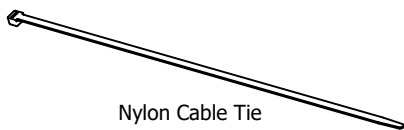

Nylon Cable Tie

[1]

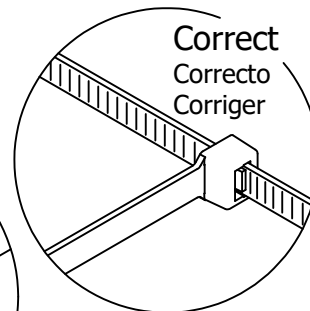
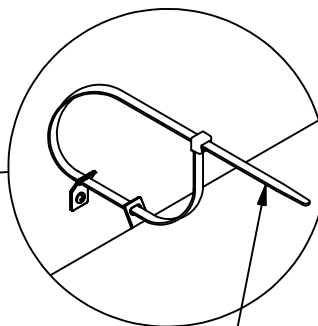
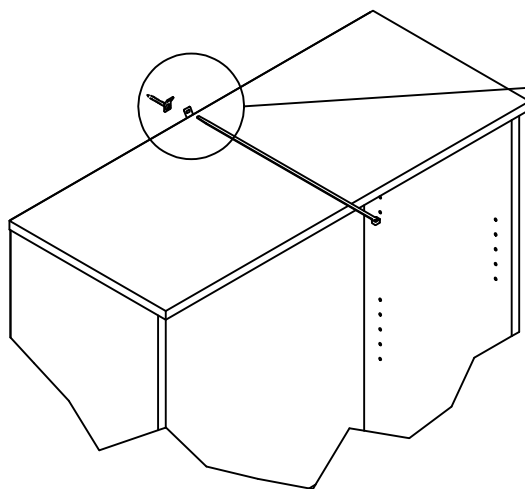

Correct
Correcto
Corriger

Pull to verify lock
Tire para verificar cerradura
Tirez pour vérifier serrure

Use replacement cable tie with minimum breaking strength of 120lbs.

Utilice reemplazo empate Cable con resistencia a la rotura mínima de 120 libras.

Utilisez remplacement Attache de câble avec une force de rupture minimale de 120 lbs.

STEP 10

H23604

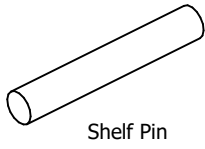

[12]

Shelf Pin

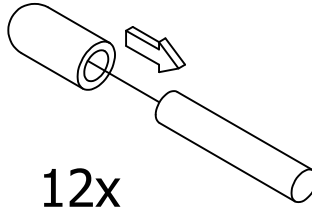

12x

H126396

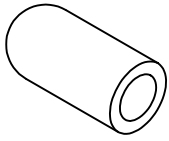

[12]

Shelf Pin Sleeve

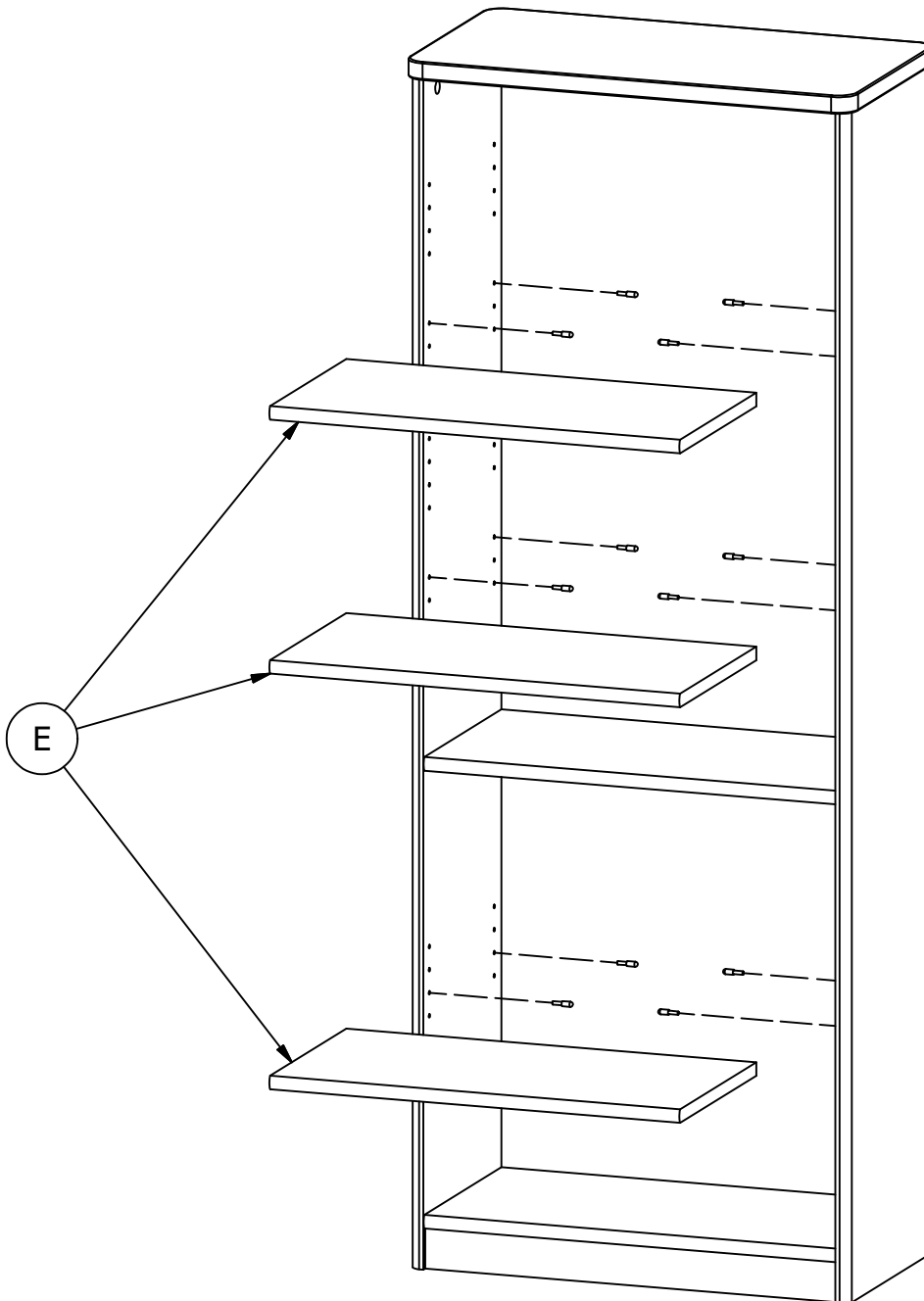

STEP 11

