

Basin Faucet Installation Manual

W-183(ES)

Warranty Duration

All components of this faucet system are covered under a lifetime limited warranty, ensuring they are free from defects in material and workmanship for the original purchaser.

Repair and Replacement

If the product shows defects in material or workmanship under normal use and within the warranty period, we will, at our discretion, either repair the product or provide a replacement at no cost to the original purchaser. Please note that proof of purchase (e.g., an invoice) is required when requesting service. The warranty does not cover damages caused by improper installation, misuse, or modifications.

Exclusions

We shall not be responsible for the following cases:

- Damage to the product caused by improper installation, misuse, unauthorized repair or replacement, or abuse (including damage during shipment).
- Damage to the product caused by improper dismantling after installation.
- Damage resulting from abnormal water pressure or impurities in water pipes, which is not covered under this warranty.
- Rust on the product due to insufficient care and maintenance, which is not covered under this warranty.
- Damage caused by natural disasters such as fire, flood, earthquake, lightning storms, etc., which is not covered under this warranty.

I hope this helps! If you have any further questions or concerns, please let me know.

Having Trouble? Contact us.

 Email: info@faucetsupport.com

 Toll Free: 1-888-969-6880



M2267
SFS-1321B

CONTENT

Basin Faucet Installation Manual -----(1-6)

CONTENIDO

Manual de Instalación del Grifo para Lavabo -----(7-12)

◆ Installation and Maintenance Instructions

1. Check the accessories list to verify that all parts are complete in this package.
2. Do not disassemble the main body by yourself.
3. Connect inlet pipes to supply valves.
4. Make sure inlet pipes and supply valves have no impurities and are cleaned, with no impurities in the pipeline.
5. After installation, check all joints for leakages.
6. Do not leave the basin faucet exposed to a severely corrosive environment.

Do's

1. In order to keep the mixer surface bright, please clean the mixer regularly.
2. Rinse the faucet with clean water and wipe it with a soft cotton cloth.
3. Use one of the following cleaners to remove dirt from the surface:
 - a. Mild liquid cleaner.
 - b. Colorless glass cleaner and powder cleaner that do not cause abrasion and can be dissolved completely.
 - c. Polish liquid that does not cause abrasion.

Don'ts

1. Avoid using cleaning powder, harsh cleaning chemicals, brushes and coarse cloth to prevent scratching and friction.
2. Do not use acid cleaners to clean the faucet as they may cause surface corrosion of the faucet. If the faucet is exposed to harmful acid substances, please rinse it immediately with water.

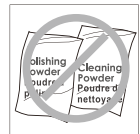
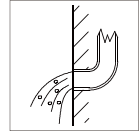

Tools Needed:

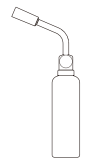
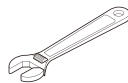
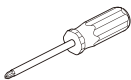

◆ **Hot and Cold Basin Faucet Set Accessories List**

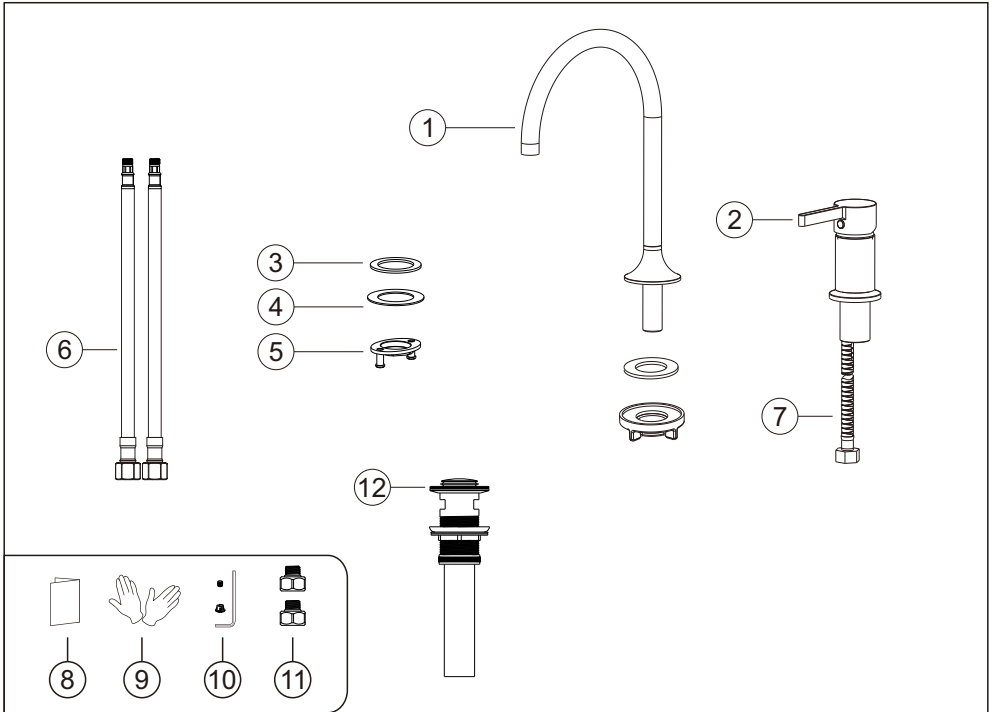

No.	Part Name	Qty	No.	Part Name	Qty
1	Faucet Body	1	7	Connect Hose	1
2	Handle	1	8	Instruction Manual	1
3	Plastic Washer	2	9	Gloves	1 pair
4	Stainless Steel Washer	1	10	Handle Parts	1 set
5	Locknut	2	11	Hose Adapter Change G9/16 To G1/2	2
6	Hot and Cold Hoses	1 pair	12	Drain	1

◆ Basin Faucet Installation

Step 1

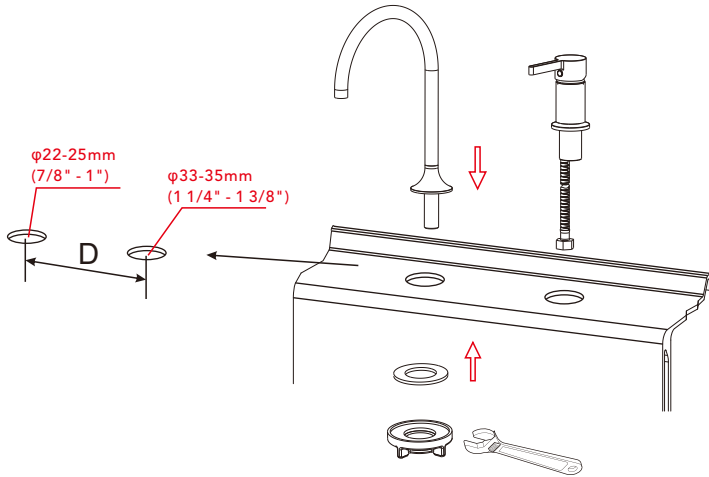

1. The countertop cutout dimensions are as shown in the diagram.
2. Faucet body through the countertop. Install faucet body gasket and mounting nut in sequence and tighten the nut with a wrench.

Step 2

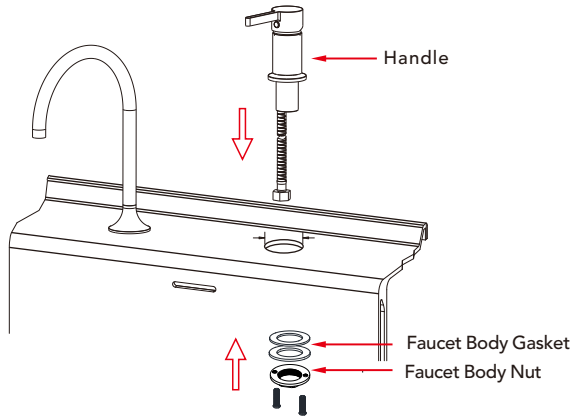

1. Pass the entire handle assembly through the pre-drilled hole in the countertop.
2. Tighten the faucet body nut from underneath.

◆ Inlet and Outlet Pipe Connections

Step 3

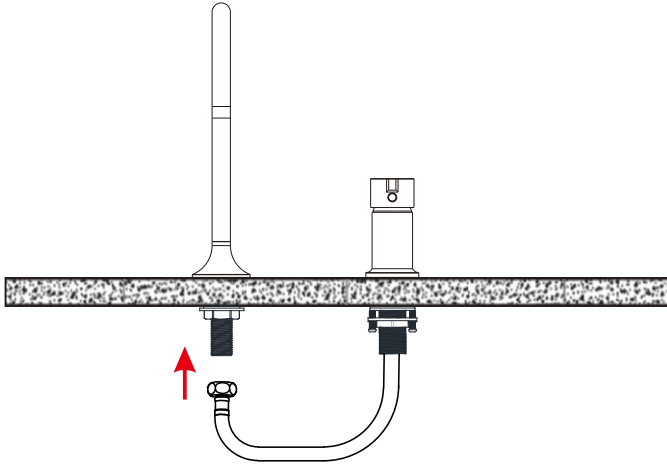

Connect the hose under the handle to the bottom of the faucet body, then tighten it clockwise with a wrench.

Step 4

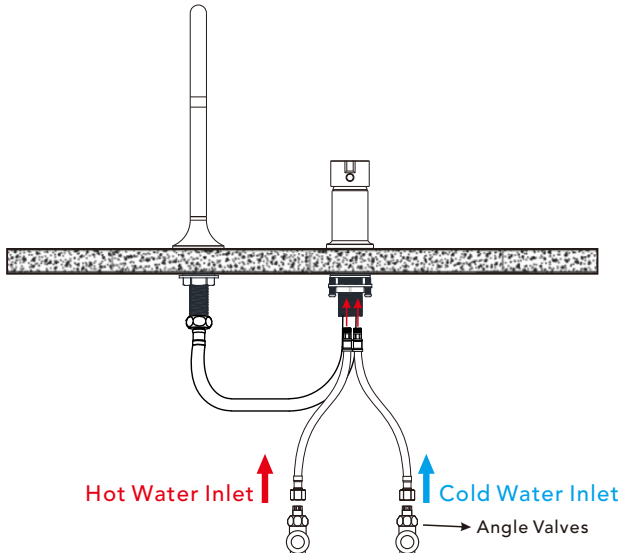

1. Connect the hot and cold inlet hoses to the hot and cold ports under the handle, and tighten clockwise.
2. Connect the other end of the hot and cold hoses to the corresponding angle valves controlling hot and cold water respectively.
3. Turn on the angle valves, open the handle to control the water flow, check if the water flows normally, and inspect for leaks at the connection points.

◆ Drain Assembly Installation

Step1

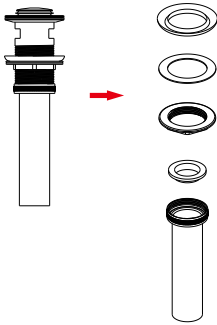

- Begin disassembling the drain assembly by removing the bottom section first. As illustrated in the image on the left, carefully detach all components step by step.

Step2

- Insert the upper section of the drain assembly into the basin's drain hole. From underneath the basin, sequentially install the rubber gasket, washer, and fixing brass sleeve onto the threaded tailpiece. Carefully rotate the brass sleeve clockwise until secure, but avoid overtightening to prevent damage to the basin or drain components.

- Finally, rotate and tighten the lower section of the drain assembly downward to secure all components and complete the installation.

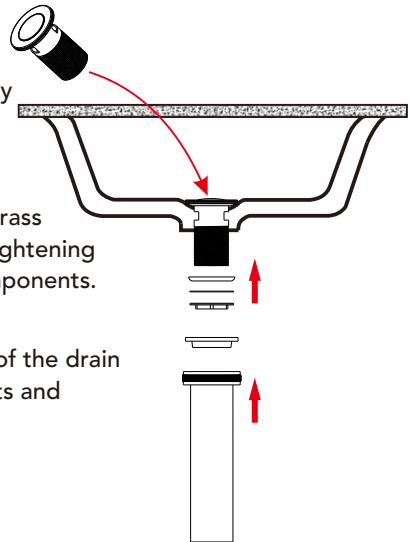

◆ Drain Assembly Installation

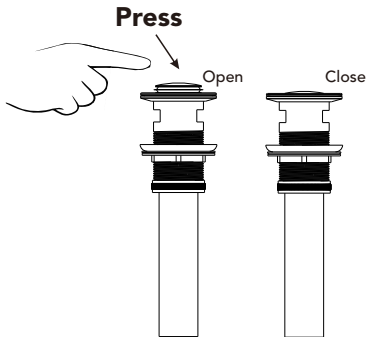

Press the pop-up button located at the top of the drain assembly to open or close the drain outlet.



Notice:

1. **Sealing Test:** Turn on the faucet and allow water to run for several minutes. Carefully inspect the drain assembly and the drainage pipe connections for any signs of leaks. If leaks are detected, adjust the tightness of the gasket and nuts to ensure a proper seal.
2. **Drainage Speed Test:** Check that water flows smoothly through the drain without any blockages or signs of slow drainage. Address any issues promptly to avoid future performance problems.
3. **Selecting the Appropriate Drain:** Different basin designs may require specific sizes and types of drains. Ensure the drain selected is compatible with your basin's size, style, and specifications before installation.

◆ Instalación y Cuestiones de Mantenimiento

1. Compruebe la lista de accesorios para verificar que todas las piezas están completas en este paquete.
2. No desmonte el cuerpo principal por su cuenta.
3. Conecte las tuberías de entrada a las válvulas de suministro.
4. Asegúrese de que las tuberías de entrada y las válvulas de suministro no tengan impurezas y estén limpias, y de que no haya impurezas en la tubería.
5. Después de la instalación, compruebe que todas las uniones no presenten fugas.
6. No deje el grifo para lavabo expuesto a un entorno altamente corrosivo.

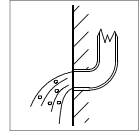
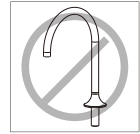

Qué Sí Hacer

1. Para mantener brillante la superficie del grifo, límpielo regularmente.
2. Enjuague el grifo con agua limpia y séquelo con un paño de algodón suave.
3. Utilice uno de los siguientes limpiadores para eliminar la suciedad de la superficie:
 - a. Limpiador líquido suave.
 - b. Limpiador de vidrio incoloro y limpiador en polvo que no causen abrasión y se disuelvan completamente.
 - c. Líquido de pulido que no cause abrasión.

Qué No Hacer

1. Evite el uso de polvos de limpieza, productos químicos de limpieza agresivos, cepillos y trapos ásperos para evitar arañazos y rozaduras.
2. No utilice limpiadores ácidos para limpiar el grifo, ya que pueden causar corrosión en la superficie. Si el grifo entra en contacto con sustancias ácidas dañinas, enjuáguelo inmediatamente con agua.

Herramientas Necesarias:

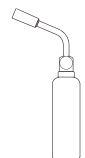
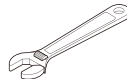
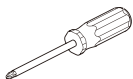

◆ Juego de Grifo para Lavabo de Agua Fría y Caliente

Lista de Accesorios

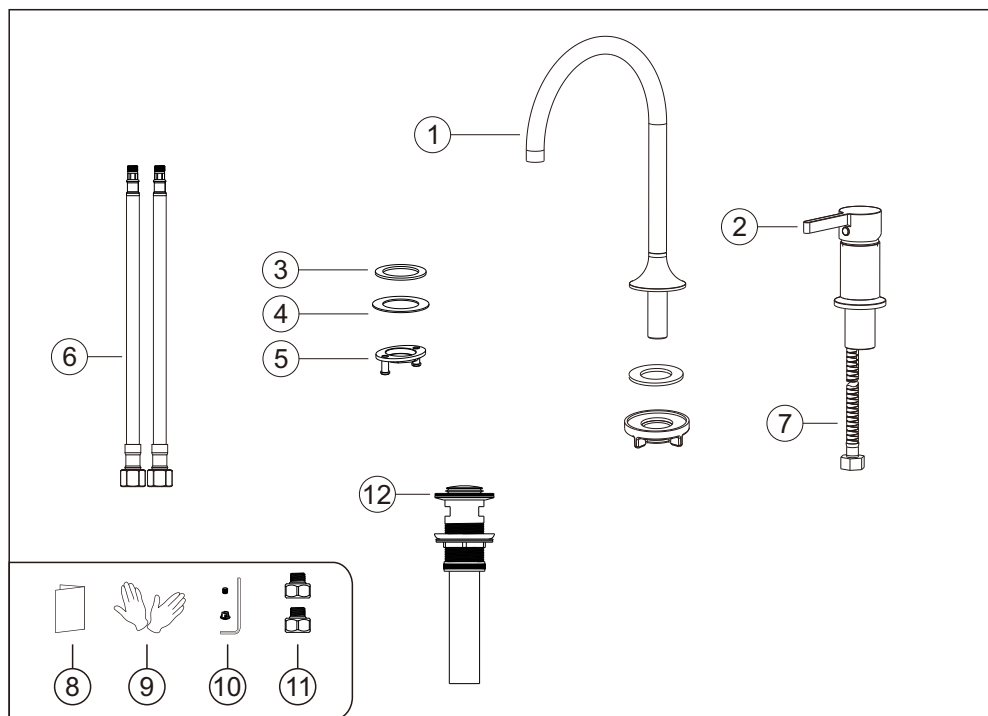

N.º	Nombre de la pieza	Cant	N.º	Nombre de la pieza	Cant
1	Cuerpo del Grifo	1	7	Conectar la manguera	1
2	Llave de Control	2	8	Manual de instrucciones	1
3	Arandela de Plástico	3	9	Guantes de protección	1 par
4	Arandela de Acero Inoxidable	2	10	Componentes de la llave/grifo	1 juego
5	Contratuerca	3	11	Adaptador de manguera (cambio de rosca G9/16 a G1/2)	2
6	Mangueras de Agua Caliente y Fría	1 par	12	Desagüe	1

◆ Instalación del Grifo de Lavabo

Paso 1

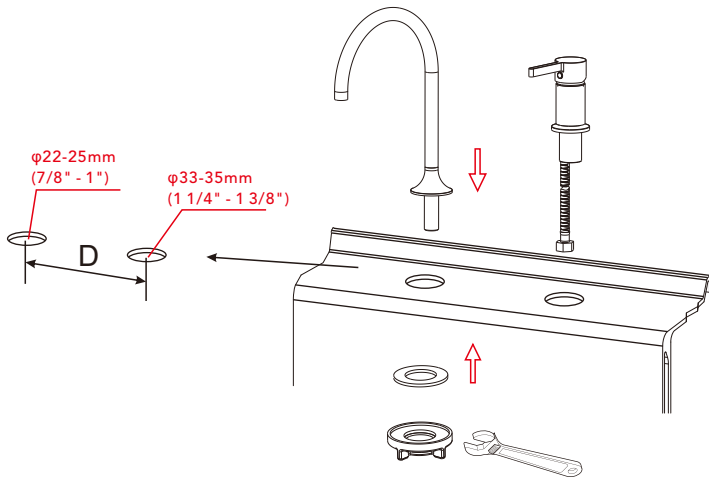

1. Las dimensiones del corte en la encimera se muestran en el diagrama.
2. Pase el cuerpo del grifo a través de la encimera. Instale, en este orden, la junta del cuerpo del grifo y la tuerca de montaje, y apriete la tuerca con una llave.

Paso 2

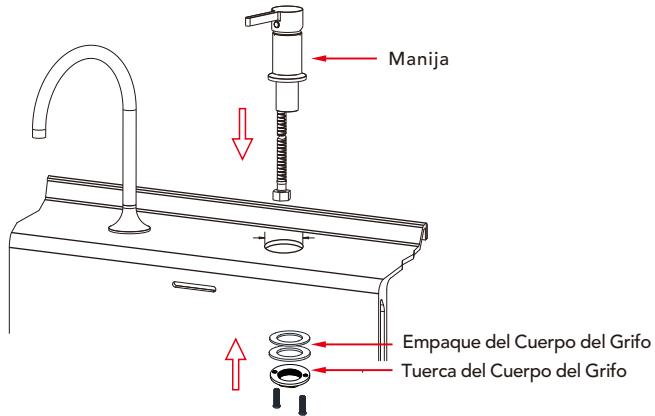

1. Pase todo el conjunto de la manija a través del orificio previamente perforado en la encimera.
2. Desde la parte inferior, apriete la tuerca del cuerpo del grifo.

◆ Instalación del Grifo de Lavabo

Paso 3

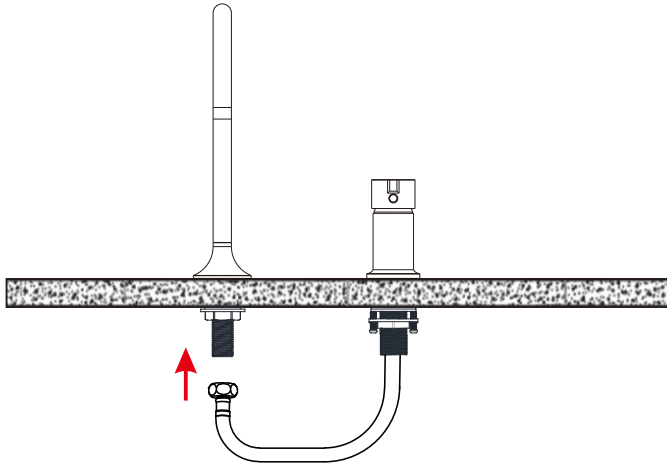

Conecte la manguera situada debajo de la maneta a la parte inferior del cuerpo del grifo y, a continuación, apriétela en sentido horario con una llave.

Paso 4

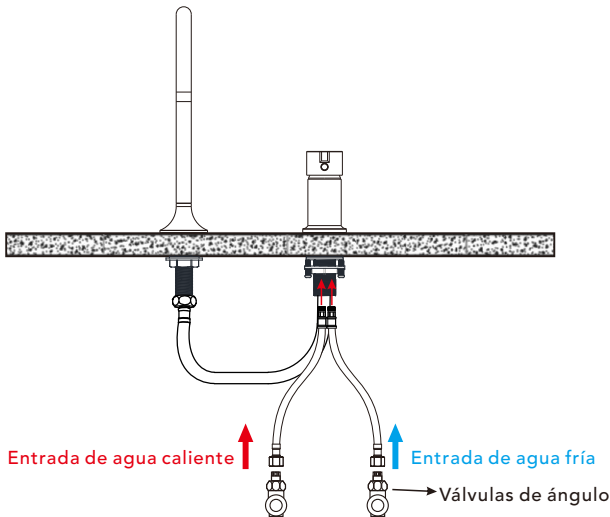

1. Conecte las mangueras de entrada de agua caliente y fría a las tomas de agua caliente y fría debajo de la maneta, y apriételas en sentido horario.
2. Conecte el otro extremo de las mangueras de agua caliente y fría a las válvulas de escuadra correspondientes que controlan, respectivamente, el agua caliente y el agua fría.
3. Abra las válvulas de escuadra, abra la maneta para controlar el caudal, compruebe que el agua fluya normalmente y revise si hay fugas en los puntos de conexión.

◆ Instalación del Desagüe

Paso 1

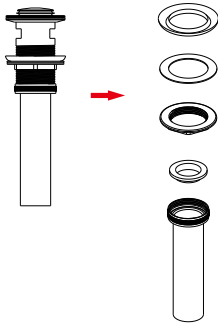

- Desmonte el desagüe comenzando por la parte inferior. Como se muestra en la imagen de la izquierda, retire todos los componentes.

Paso 2

- Inserte la parte superior del desagüe en el orificio de drenaje del lavabo y, desde la parte inferior hacia arriba, coloque secuencialmente la junta de goma, la arandela y la manga de fijación de latón. Gire la manga de latón hacia la derecha hasta que quede ajustada, pero no apriete en exceso para evitar dañar el lavabo o el desagüe.
- Finalmente, continúe girando y apretando hacia abajo la parte inferior de los componentes del desagüe para completar la instalación.

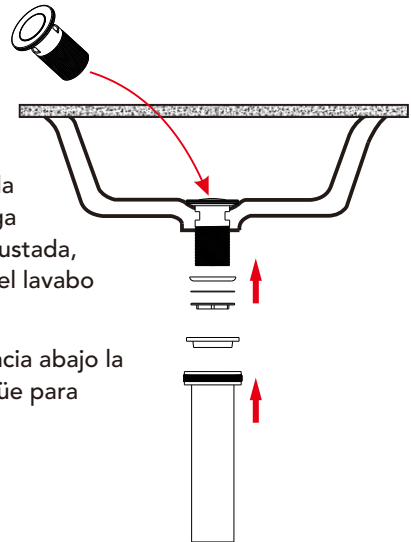

◆ Instalación del Desagüe

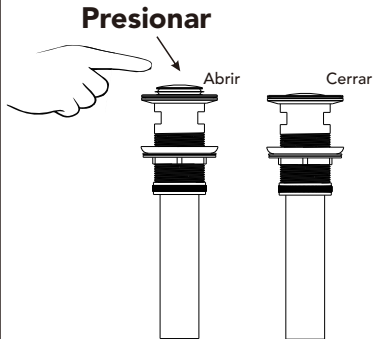

Presione el botón emergente en la parte superior del desagüe para abrir y cerrar la salida de agua.



Aviso:

1. Prueba de sellado: Abra el grifo y deje correr el agua durante unos minutos. Observe el desagüe y las conexiones de la tubería de drenaje para detectar posibles fugas. Si encuentra alguna fuga, reajuste la junta y las tuercas hasta lograr un sellado adecuado.
2. Prueba de velocidad de drenaje: Asegúrese de que el agua drene sin problemas, sin bloqueos ni problemas de drenaje lento.
3. Elija el desagüe adecuado: Diferentes lavabos pueden requerir distintos tamaños y tipos de desagües. Asegúrese de que el desagüe que compre sea compatible con su lavabo.