

Assembly Instructions

Caution: You must read this before you proceed

Please look in the underneath Leg for hardware packs and legs .

Table

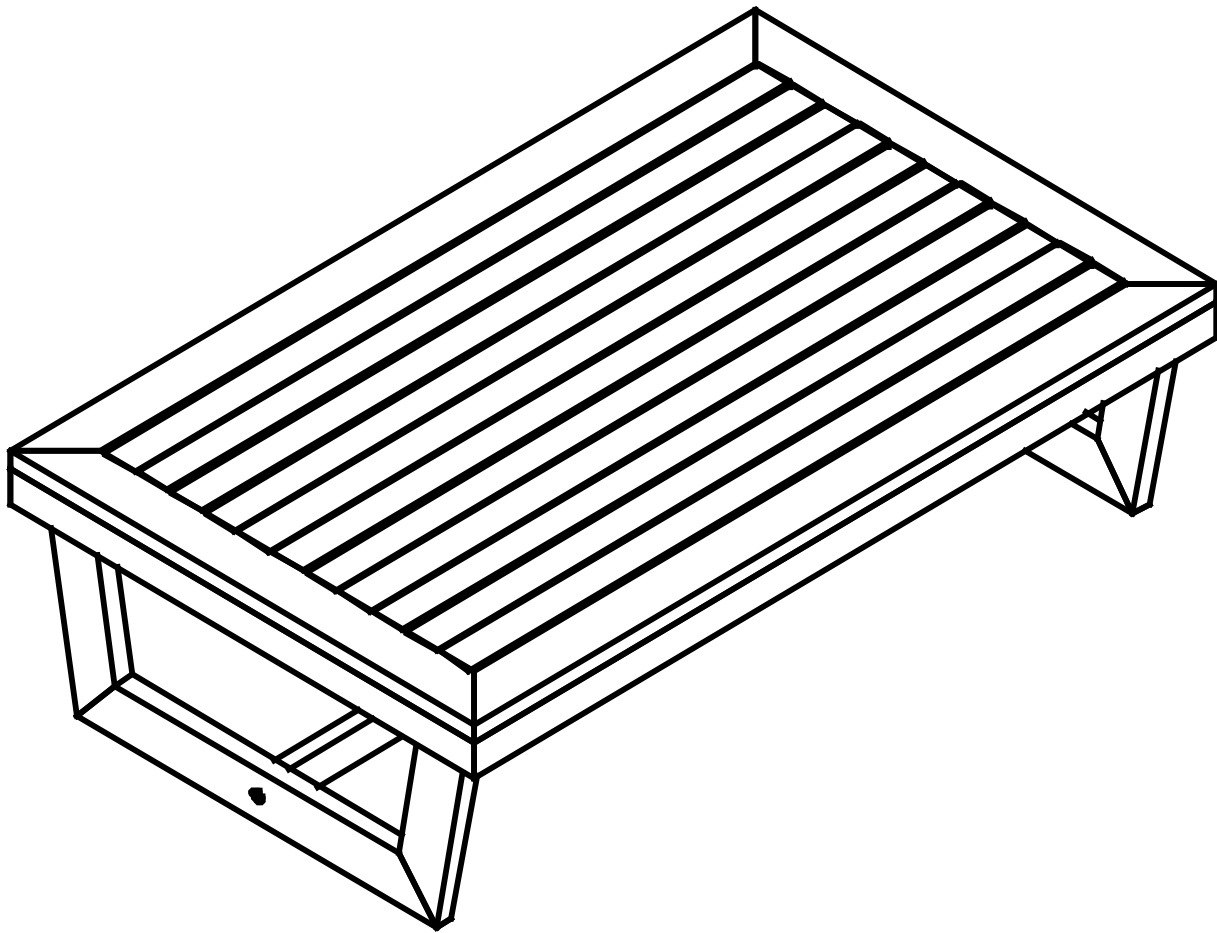

Caution: This Chair is NOT a TOY.



Keep your child/children at bay during the assembly process.

Whenever moving/lifting the Chair and to prevent damage to the Chair, two adults are required to execute these actions.

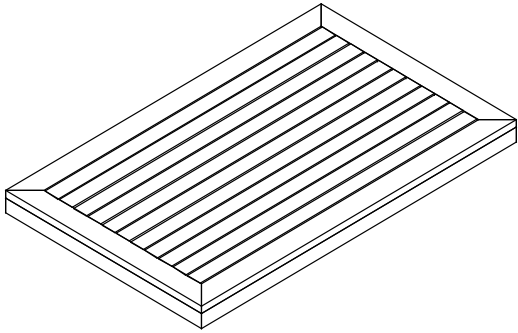
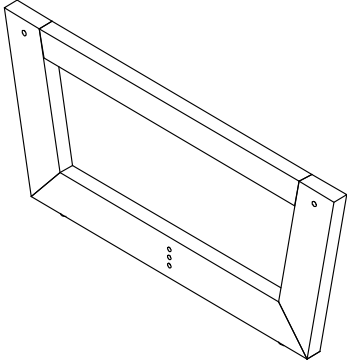
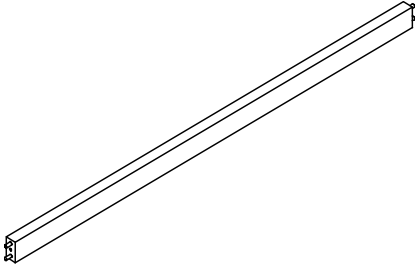
Part List

Label	Picture	Description	Qty
A		Table Top	1
B		Leg	2
C		Coss Bar	1

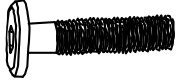
Hardware

No.	Picture	Description	Qty
①		Bolt (M6x35mm)	5
②		Screw (M6x50mm)	3
③		Allen Wrench M4	2

Assembly Preparation

Before Beginning Assembly:

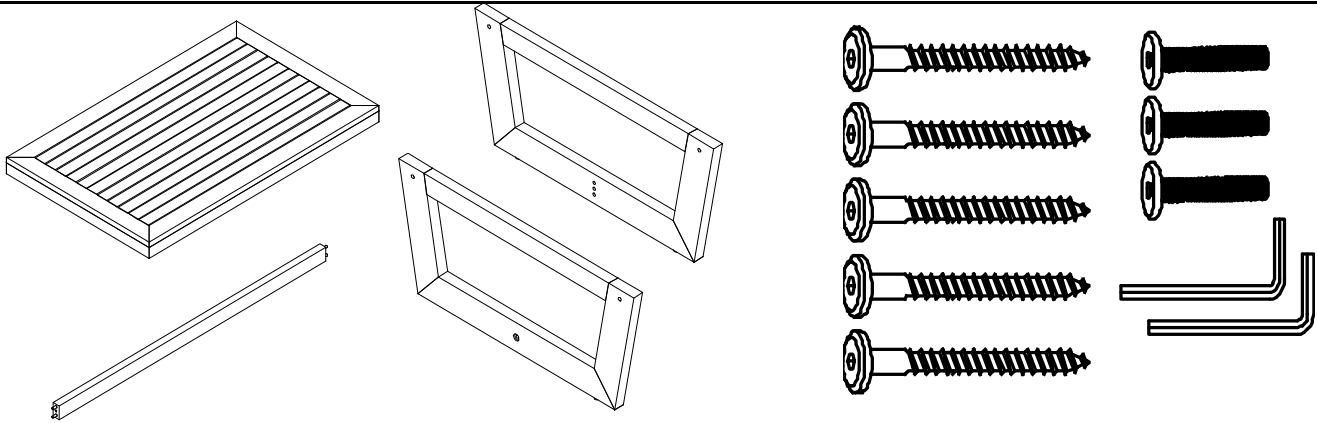

Read instructions, cover to cover.



Have 2 adults on hand for assembly.



Do not assemble on flooring or carpet.



Assemble on a clean non-marring surface (packing foam).



Save all packaging until finished.

Assembly Steps

Overview

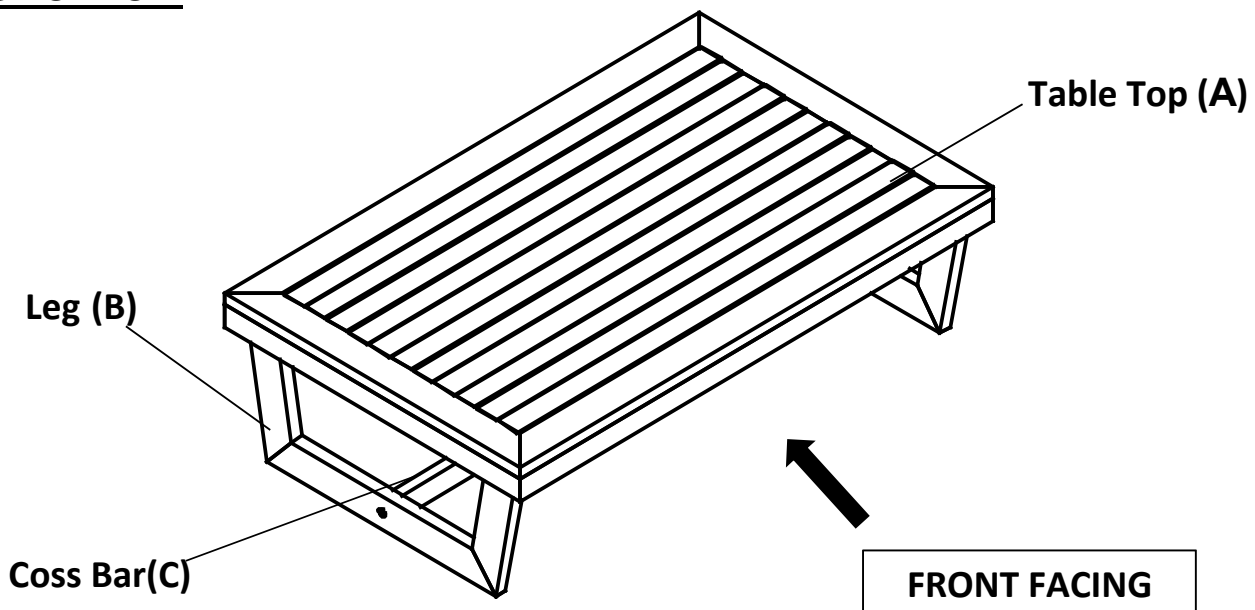

This Chair has multiple parts and may require up to 30 minutes to assemble. To give you an overview of the Chair parts, the above picture is to help you put the various parts into perspective. Please read through the instructions below to familiarise yourself with the parts and steps before assembly.

Step 1

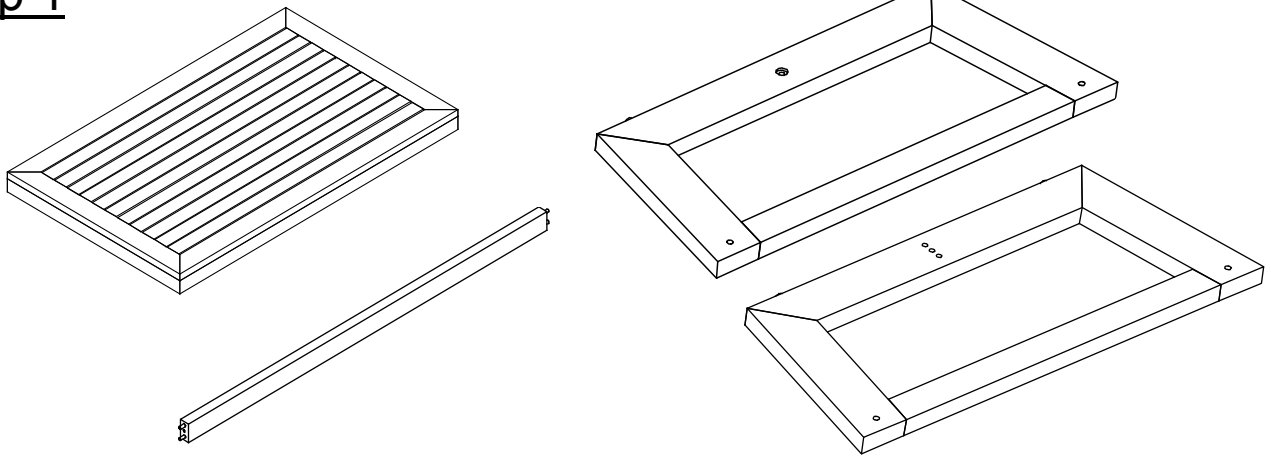

Unpack and place all parts on a clean, non-marring surface.

Step 2

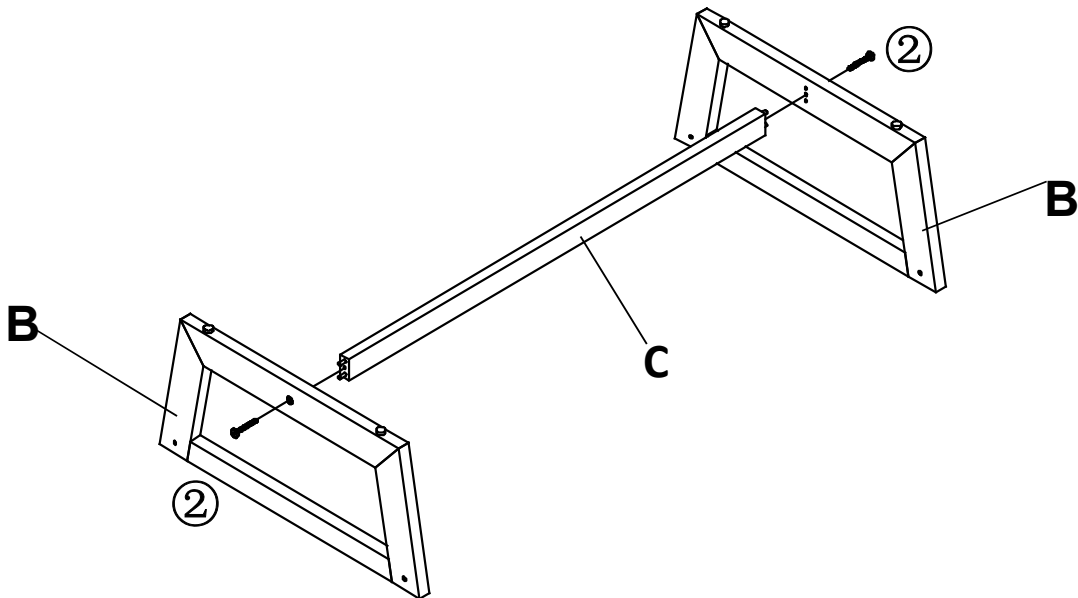

Place the Leg (B) and Coss bar (B) facedown as shown above.

Attach the Leg(B) to Coss Bar (C) by using Screw(②) with Allen Wrench(③) as shown in picture above.

Do not fully tighten the Bolts.

Step 3

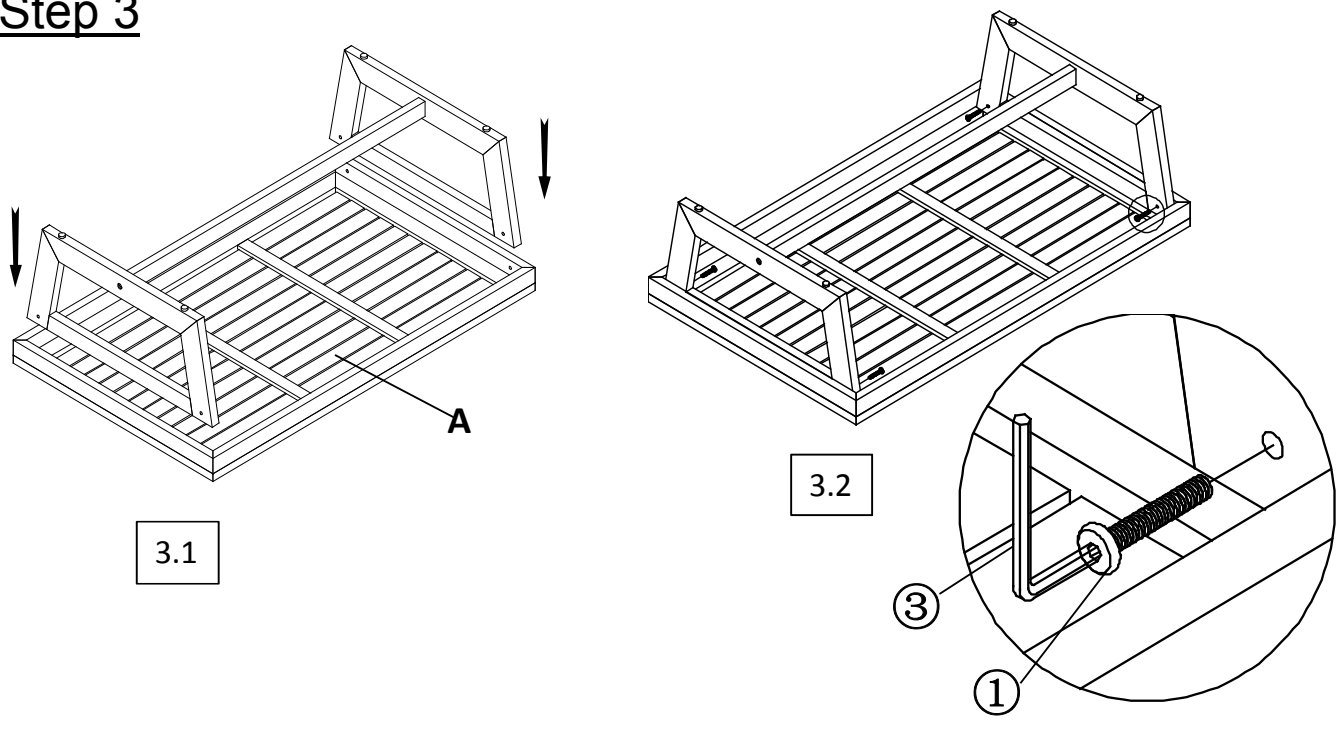

3.1) Place the Table Top(A) facedown as shown above.

3.2) Attach the Leg(B) to Table Top(A) by using Bolts(1) with Allen Wrench(3) as shown in picture above.

Do not fully tighten the Bolts.

Step 4

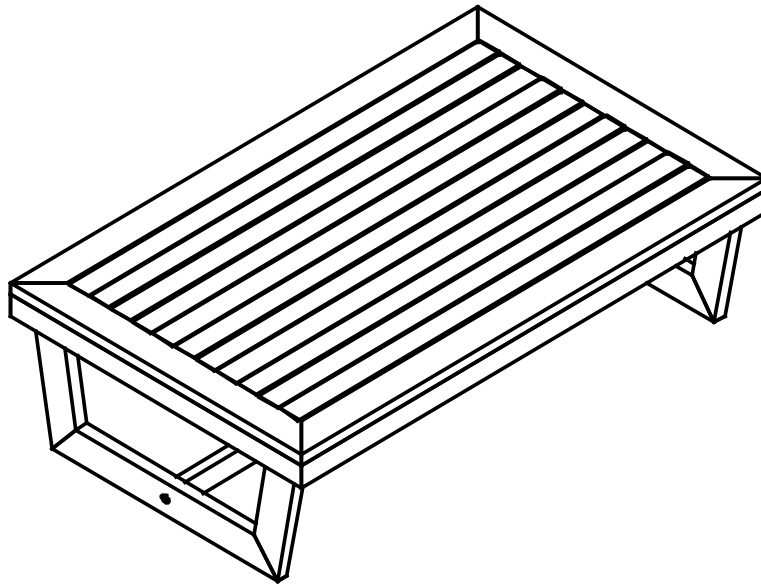

Place the Table onto a flat, level surface.

Then EXERT pressure, floorwards onto the Table with both hands.

This pressure will help the Table reach full alignment at all joints.

















In a sequential manner, gradually tighten all Bolts at all joints until evenly secured.

Inspect the Table and make sure all parts are adequately connected.

Your Table is ready for use.

This Table can only be used on a flat, level surface.

Care & Maintenance

-   ● Do not put hot items directly on furniture surface
 -   ● Do not clean furniture with harsh cleansers or polish.
 -   ● To obtain the longest lifespan of your outdoor products, minimizing exposure to direct sunlight is recommended.
 -   ● Children should not climb or jump on the furniture.
 -   ● Do not write on furniture without a padded barrier to protect the surface.
 -   ● To obtain the longest lifespan of your outdoor products, avoid extended and lengthy exposure to rain, snow, and direct sunshine. Whenever possible cover the product and /or place under patio or awnings.
 -   ● Not for commercial use. For residential use only .
 -   ● Stains may be removed with mild soap solution and damp cloth.
-
-   ● Dust and pick-up spills using a clean, non-colored, lint-free cloth .