

GREY OFFICE CHAIR

ASSEMBLY GUIDE

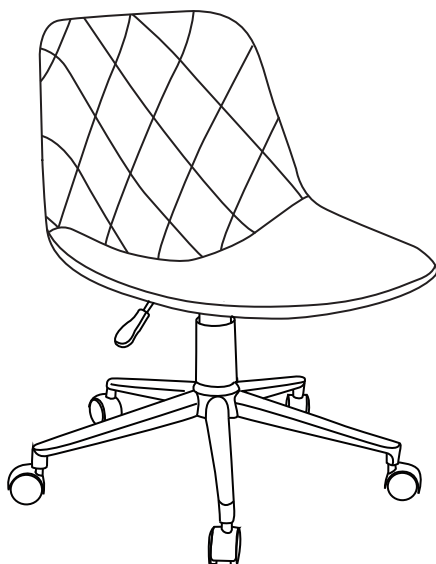

Important - Please read these instructions fully before starting assembly



SAFETY AND CARE ADVICE



NO POWER TOOLS

SAFETY AND CARE ADVICE

- Check you have all the components and tools listed.
- Remove all fittings from the plastic bags and separate them into their groups.
- We do not recommend the use of power drills/drivers for inserting screws, as this could damage the unit. Only use hand screwdrivers and Allen keys.
- Keep children and animals away from the work area, small parts could cause choking if swallowed.
- Make sure you have enough space to lay out the parts before starting.
- Assemble the item as close to its final position (in the same room) as possible.
- Do not overtighten the nuts to avoid causing damage to the threads.
- Only clean using a damp cloth and mild detergent, do not use bleach or abrasive cleaners.
- From time to time check that there are no loose screws on this unit
- This product should not be discarded with household waste. Take to your local authority waste disposal centre

IMPORTANT INFORMATION



15 MINUTE
BUILD



TWO
PERSON



MAXIMUM
CAPACITY 110Kg

PLEASE CHECK CAREFULLY AND MAKE SURE YOU HAVE ALL FITTINGS AND TOOLS LISTED BELOW BEFORE YOU START.

DESCRIPTION	PART NAME	Q'ty(PCS)
①		1
②		1
③		1
④		1
⑤		1
⑥		5

A BOLT M6x18mm 2 PCS

B BOLT M6x25mm 2 PCS

C ALLEN KEY 1 PCS

NOTE: The quantities above are the correct amount to complete the assembly.
In some cases more fittings may be supplied than are required.

STEP 1

Use a clean, flat, soft surface to avoid any bumps or scratches. Carefully unpack your office chair.

Gently push 1 x castor [6] into each socket of the star base [5]. It should fit snugly without much force.

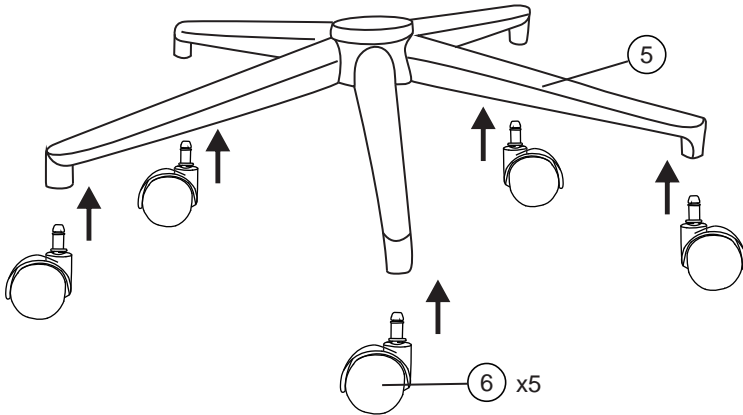

STEP 2

Insert the gas lift [4] into the center of star base [5] as shown.
Cover the gas lift [4] with telescopic gas lift cover [3].

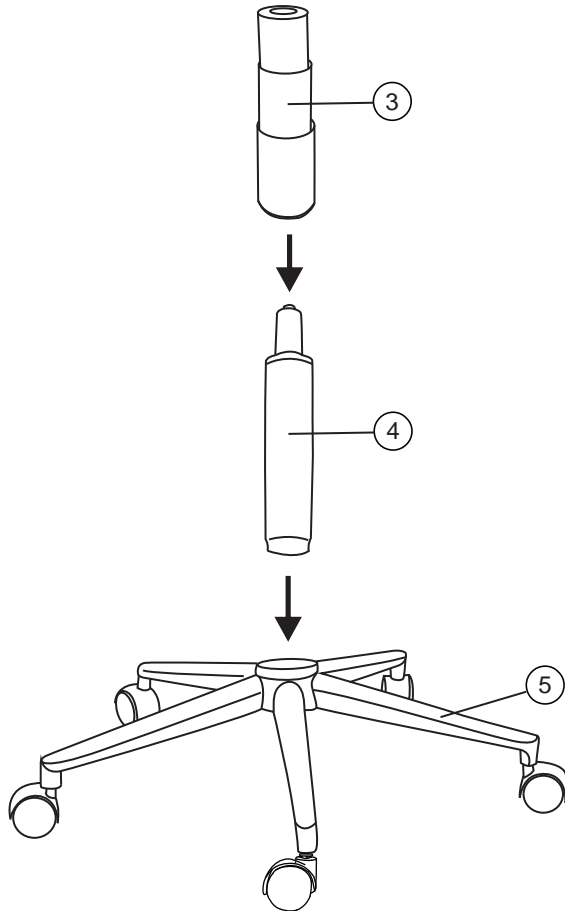

STEP 3

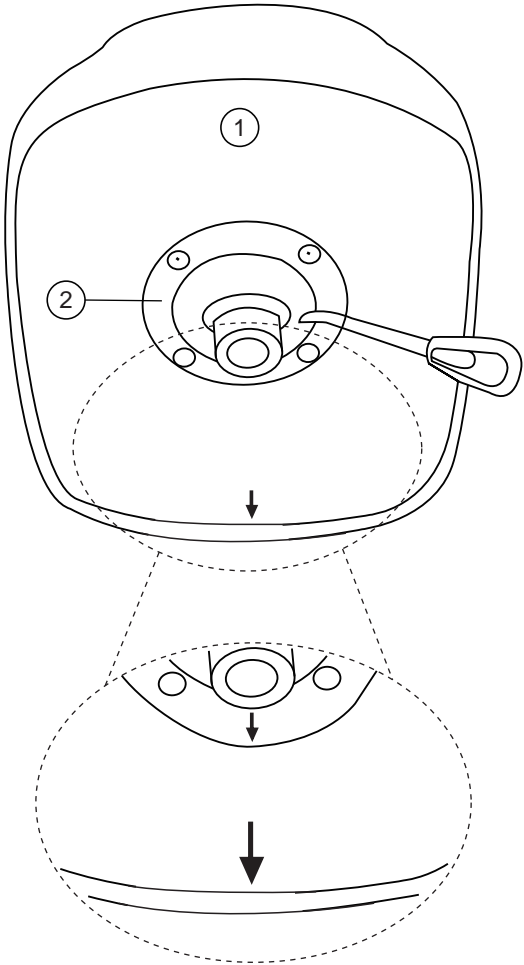

Place the seat [1] upside down on a soft surface.
Place the mechanism [2] onto seat [1] as shown, making sure the arrows on both parts are pointing in the same direction.

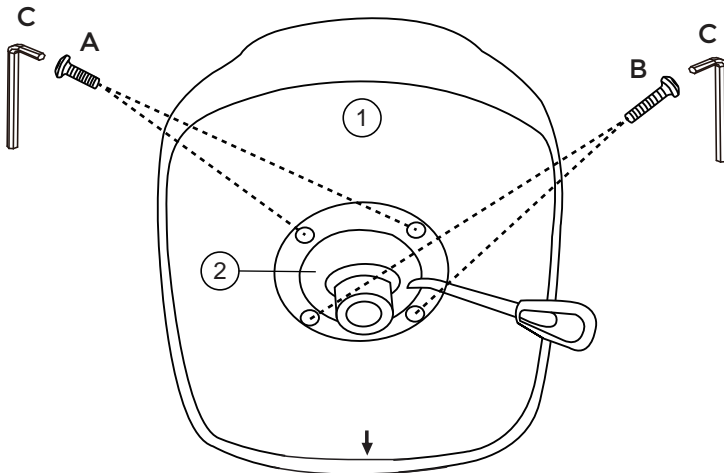

STEP 4

Align the mechanism [2] to the pre-drilled holes on the seat [1] and attach using with 2 x bolts [A] and 2x bolts [B]. Tighten all bolts using Allen key [C].



		
C Allen Key	A M6x18 2 pcs	B M6x25 2 pcs

STEP 5

Carefully and with help, place the assembled seat [1] onto the gas lift [4], making sure the gas lift [4] top is inserted into the hole on mechanism [2] as shown.

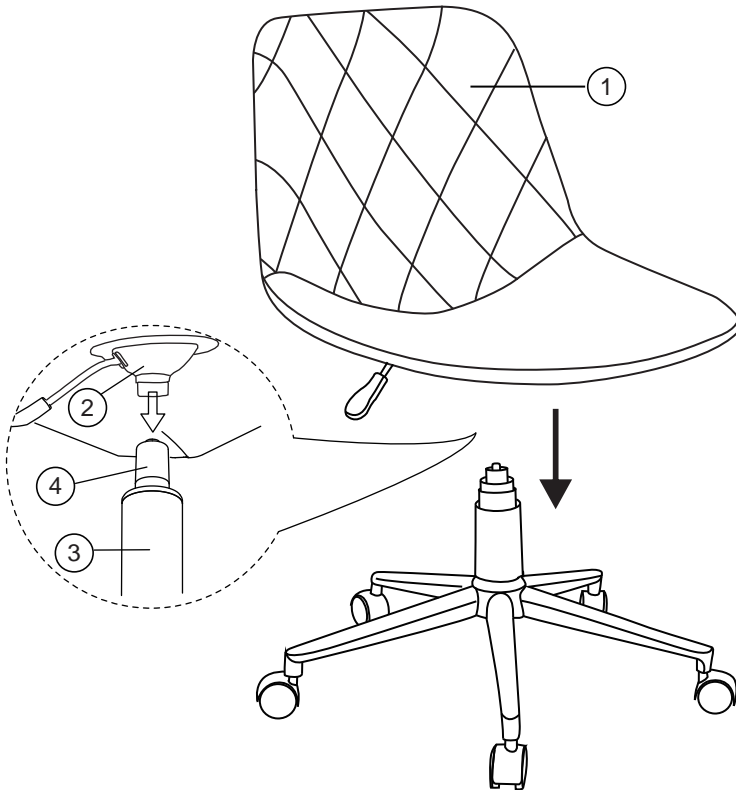

STEP 6

Your chair is ready to use!

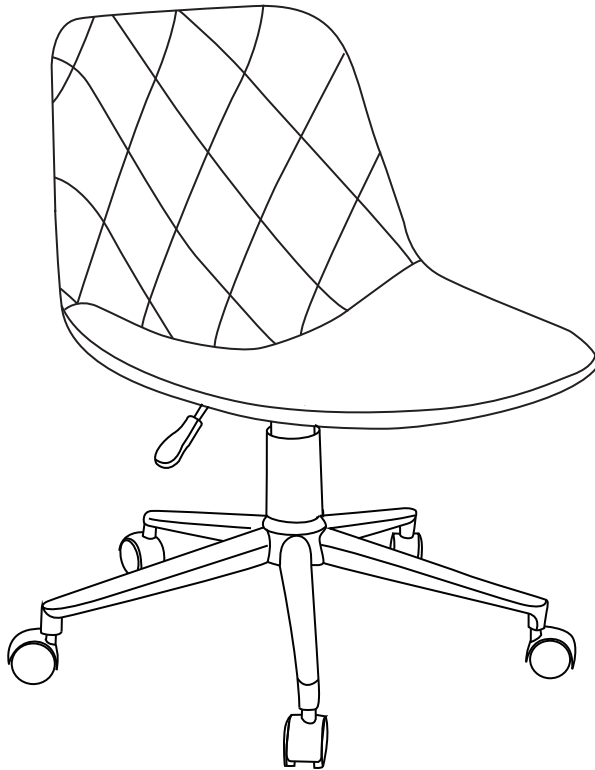



OUR 2 YEAR GUARANTEE

our products come with a 2 year guarantee to give you peace of mind shopping

some garden furniture items have a 1 year guarantee



WHAT THE GUARANTEE COVERS



PRE-INSERTED FIXINGS

e.g. loose metal threads



FAULTY JOINTS

e.g. legs bending



EXTERNAL FIXING FAULTS

e.g. metal discs removing from table top



STRUCTURAL INTEGRITY

e.g. the frame of the product