

# ASSEMBLY INSTRUCTIONS

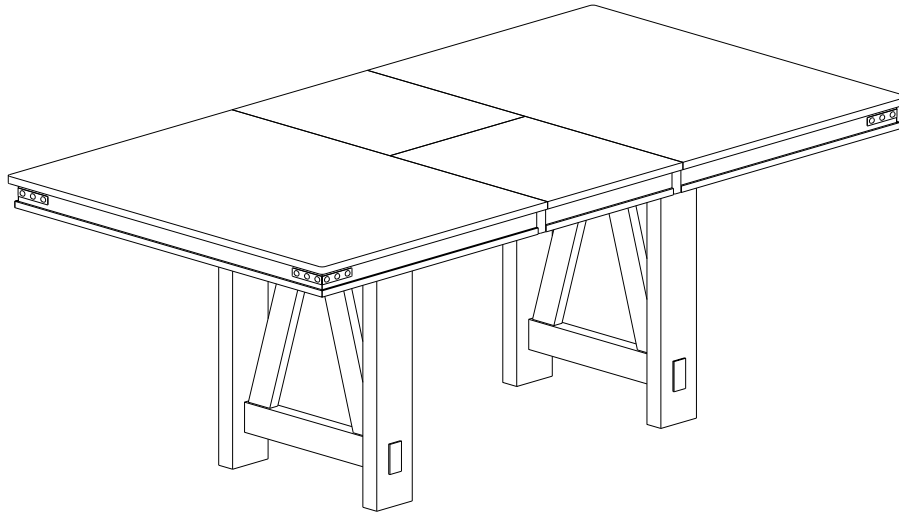

## DINING TABLE



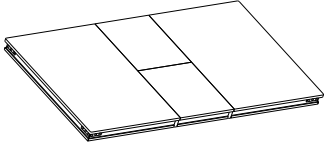
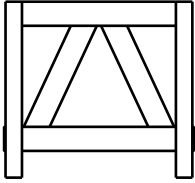

### NOTE TO CUSTOMERS:

- For ease and speed of assembly we recommend that before you commence each step of the assembly that you identify all the parts required to complete that step.
- We recommend that where possible you allow sufficient space to assemble the item as close as possible to the place where it will be once assembled.
- For the protection of your furniture we recommend that the product is placed on protected surfaces during assembly to prevent any damage.
- During assembly do not over tighten the screws or bolts, as this may damage the product.
- Please ensure you retain all the product packaging until the item is completely assembled.
- Periodically check all fitting and re-tighten as necessary.
- Never allow any liquids to remain on your furniture as absorption can cause the wood to warp or finish to de-laminate.
- It is recommended that this item should be assembled by two adults.

## PARTS IDENTIFICATION

A-	Table Top		1 pc
B-	Trestle Leg		2 pcs
C-	Mounting Plate		2 pcs

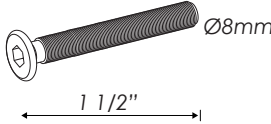
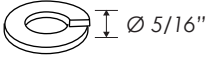
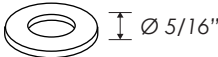
## HARDWARE IDENTIFICATION

1-	JCBC Bolt M6 x 70mm	 Ø8mm 1 1/2"	16 pcs
2-	Lock Washer 5/16" x 13mm	 Ø 5/16"	16 pcs
3-	Flat Washer 5/16" x 18mm	 Ø 5/16"	16 pcs
4-	Allen Key M5 x 2 1/2"		1 pcs

NOTE: Quantities shown are for one bench. Bolts are metric screw threads

### STEP 1

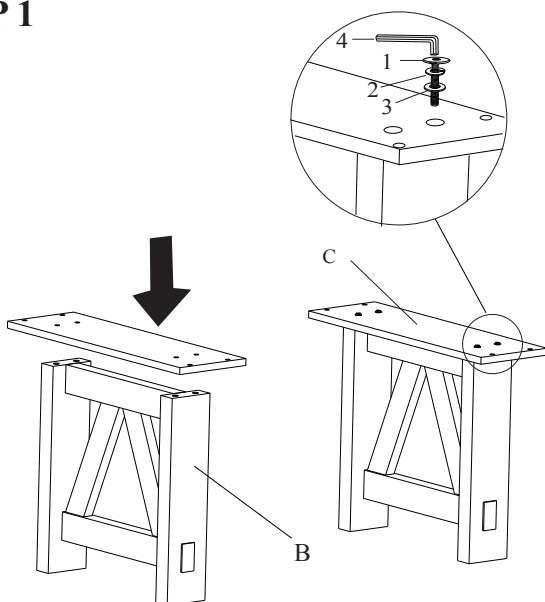

### STEP 2

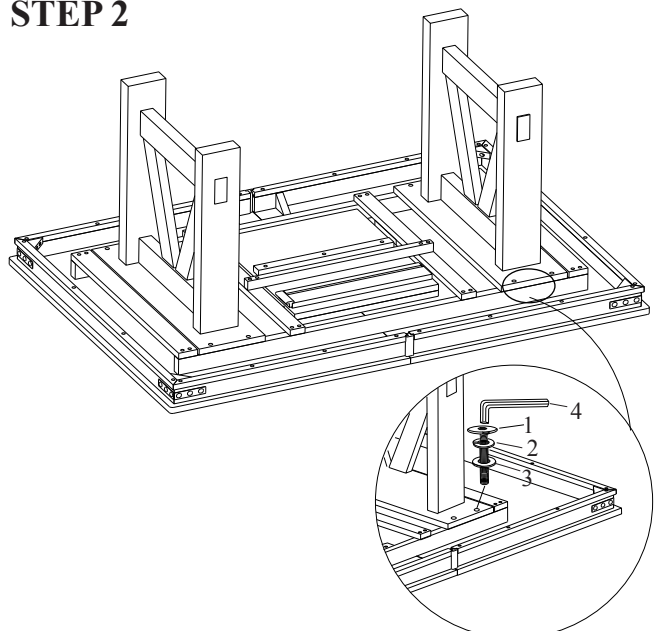

# ASSEMBLY INSTRUCTIONS

## DINING TABLE

**STEP 3**

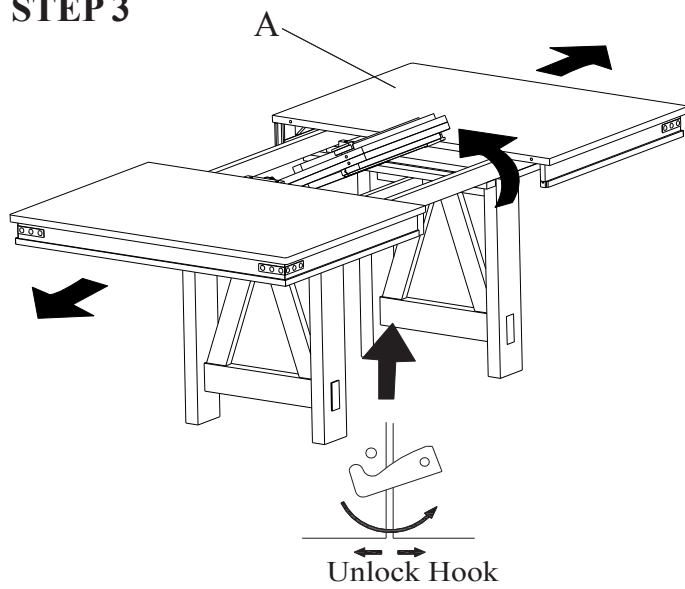

**STEP 4**

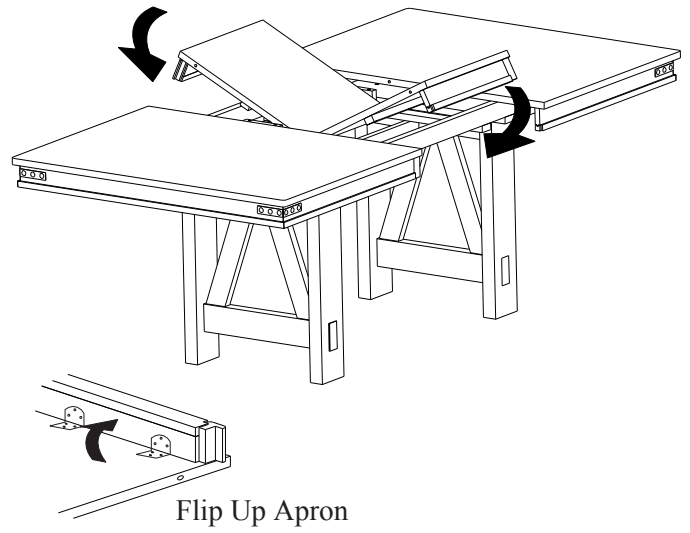

**STEP 5**

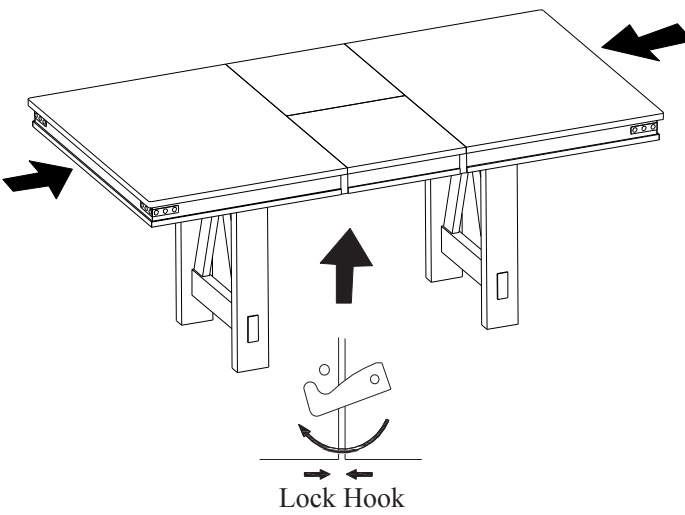

**STEP 6**

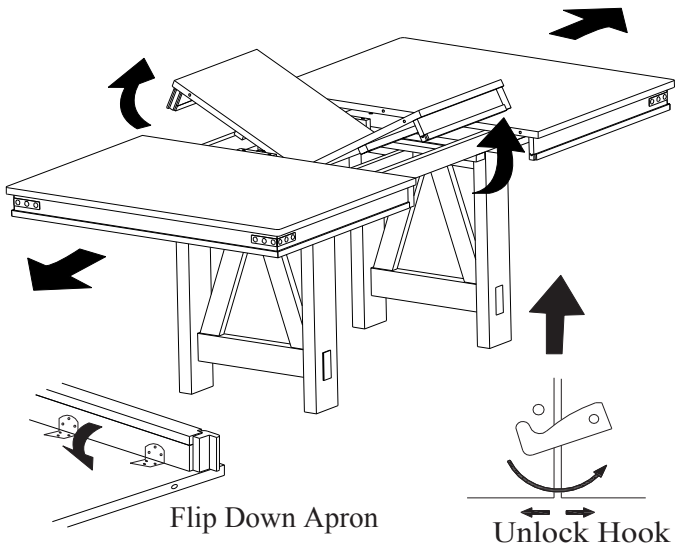

**STEP 7**

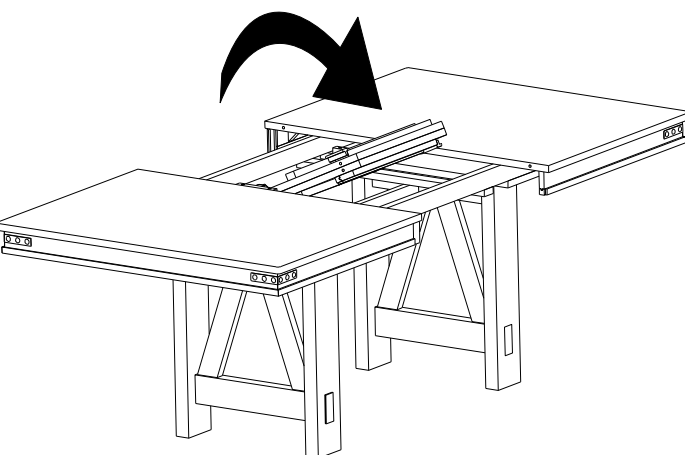

**STEP 8**

