

# Assembly Instructions (-86 pushback recliner)

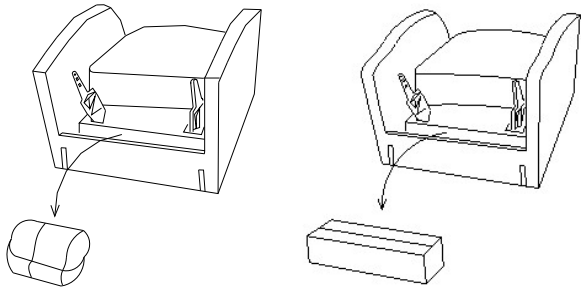

Figure 1

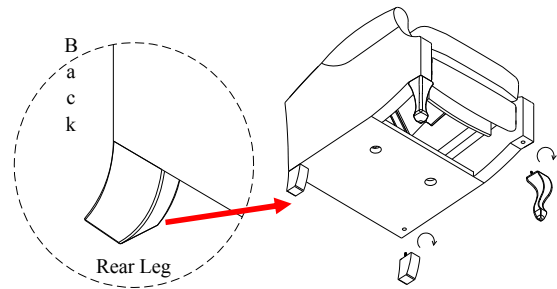
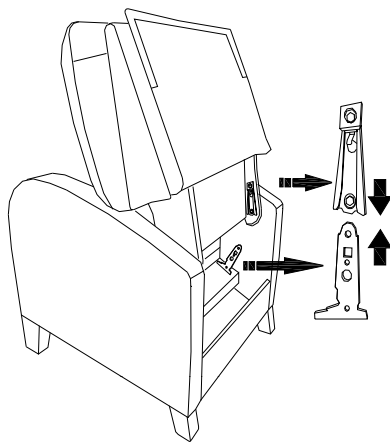

Figure 2

**1.** The Wooden Legs are located at the rear of seat cushion, remove all the Wooden Legs from the package or box (See Figure 1) and apply the plastic washer on top that is provided. Attached each Wooded Leg to corresponding pre-drilled holes by hand turning on clockwise direction as figure underneath(See Figure 2).



**2.** Align top brackets on both sides with metal posts.

**3.** Press both sides of the back firmly down and into a locked position. The back should automatically lock into place.

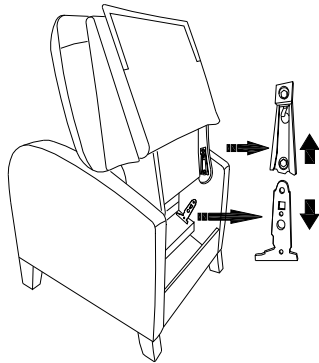
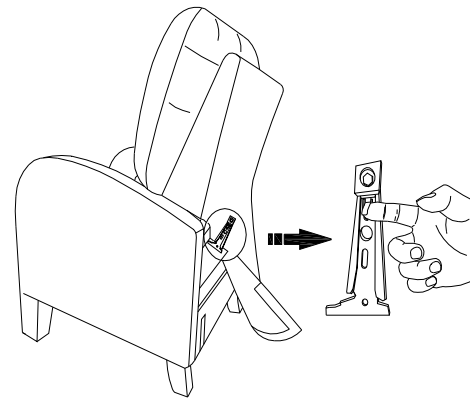
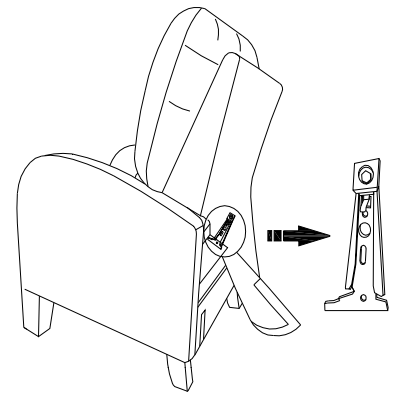

**4.** To remove the back, lift the tab on both sides and pull the back straight up. Note: if there is difficulty in getting the back to lock into place check to see that the tab is engaged in the proper space.

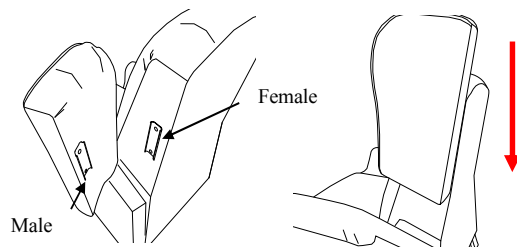

**6.** KD Wings(if applicable)  
Insert the male KD Bracket into the slot of the female Bracket pressing firmly downward until the frame is tight.

**5.** To make the chair easier to recline, tip it on its back and turn the tension adjusters counter clockwise. Turn them clockwise to increase the resistance needed to recline. Note: to keep the chair tension balanced, turn both sides in equal amounts.

