

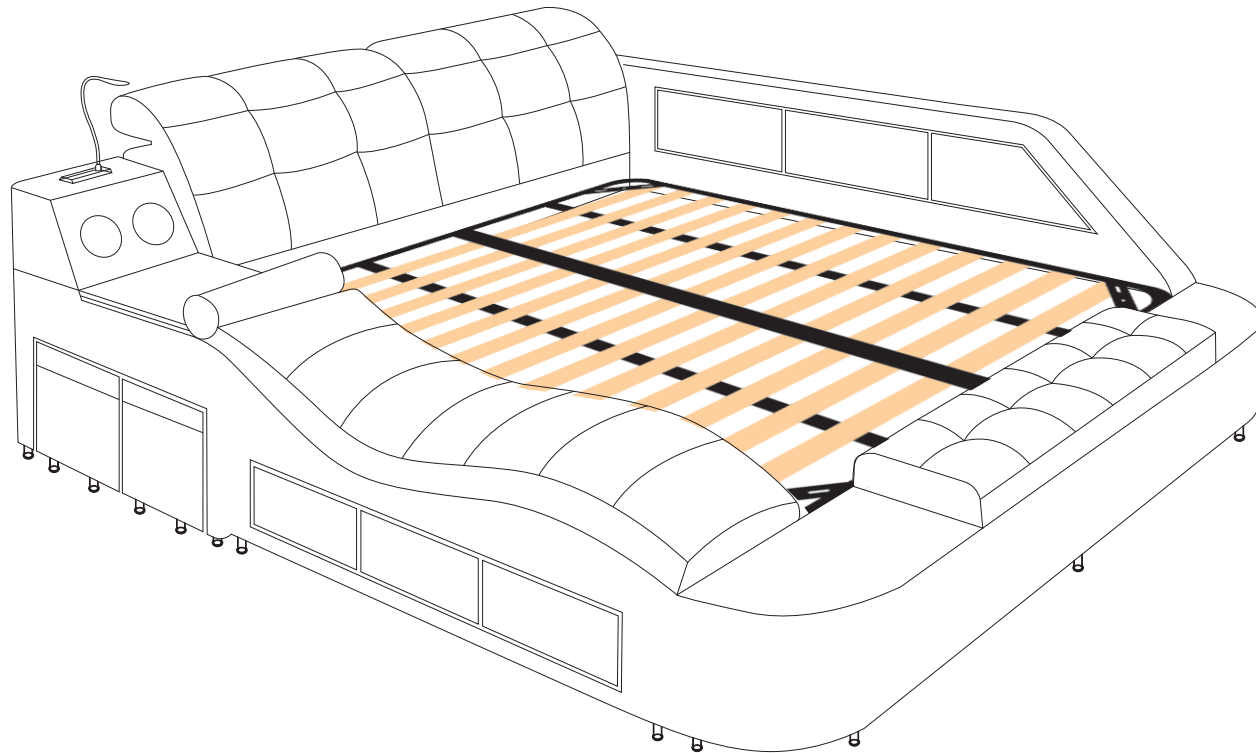

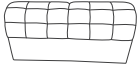







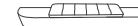

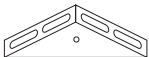

# Assembly Instruction

ITEM NO.:



NO.:	PARTS LIST		QTY
A	HEADBOARD		1 PC
B	BED SIDE WITH RECLINER		1 PC
C	BED SIDE WITH BOOKCASE		1 PC
D	FOOTBOARD		1 PC
E	OTTOMAN		2 PCS
F	BLUETOOTH SPEAKER		1 PC
G	SLAT		1 PC
H	FEET 50mm		20 PCS
I	SUPPORT LEG 230 mm		4 PCS
J	SUPPORT LEG 230 mm		4 PCS

NO.:	HARDWARE LIST		QTY
1	BIG BRACKET		4 PCS
2	SMALL BRACKET 8*10mm		4 PCS
3	SCREW 8*25 MM		32 PCS

NO.:	HARDWARE LIST		QTY
4	SCREW 8x50 MM		12 PCS
5	SCREW 30 MM		80 PCS
6	NUT		8 PCS

Remark:Phillips head screw driver is required in the assembly process; however, manufacturer does not provide this item.

# Assembly Instruction

ITEM NO.:

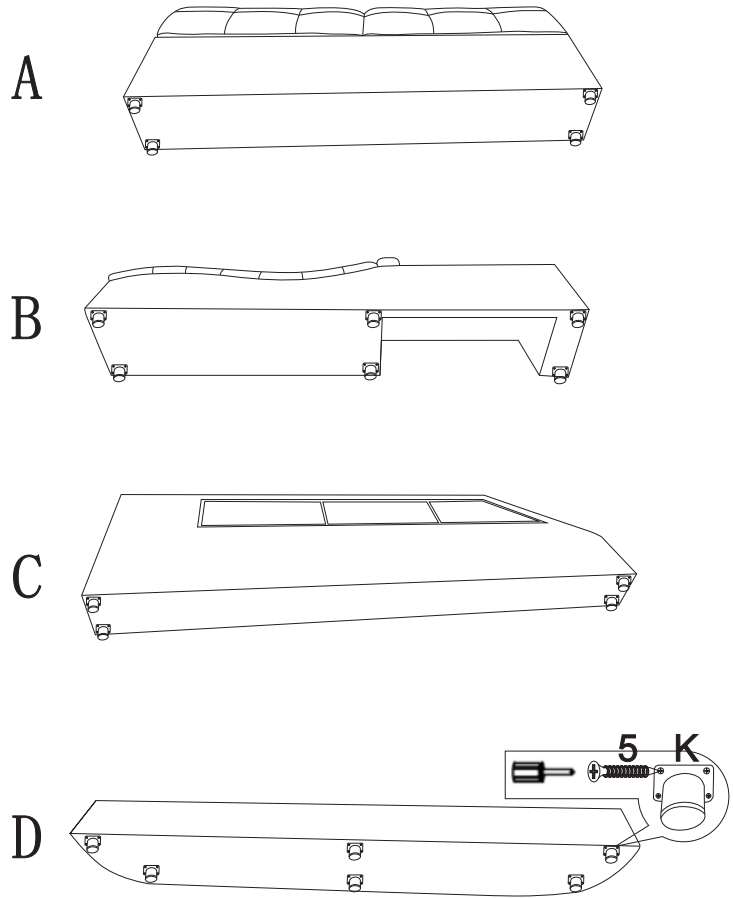

Step1

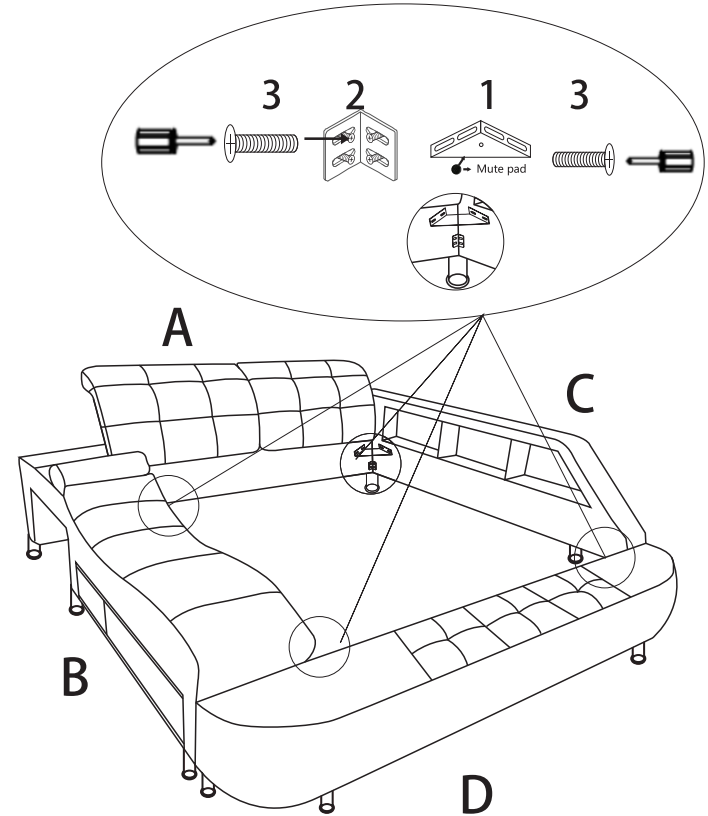

Step2

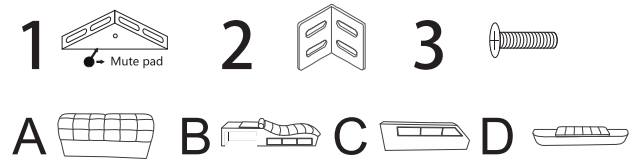

# Assembly Instruction

ITEM NO.:

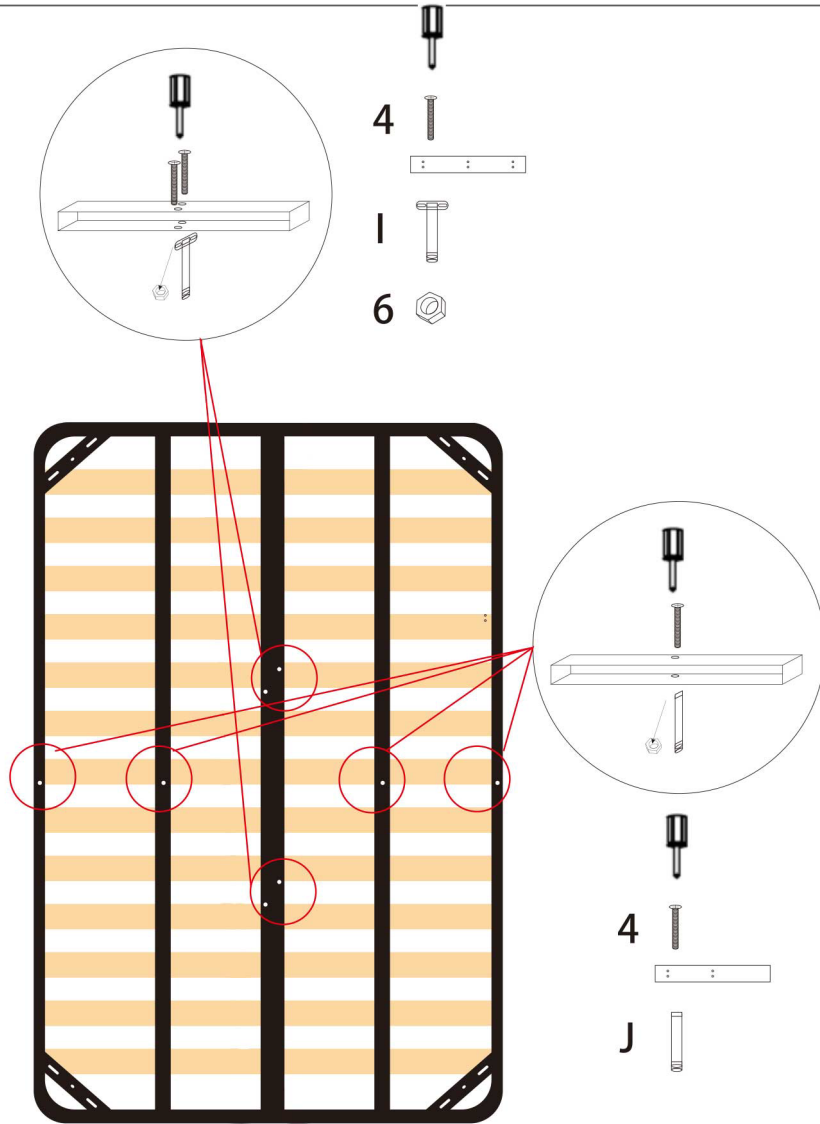

Step3

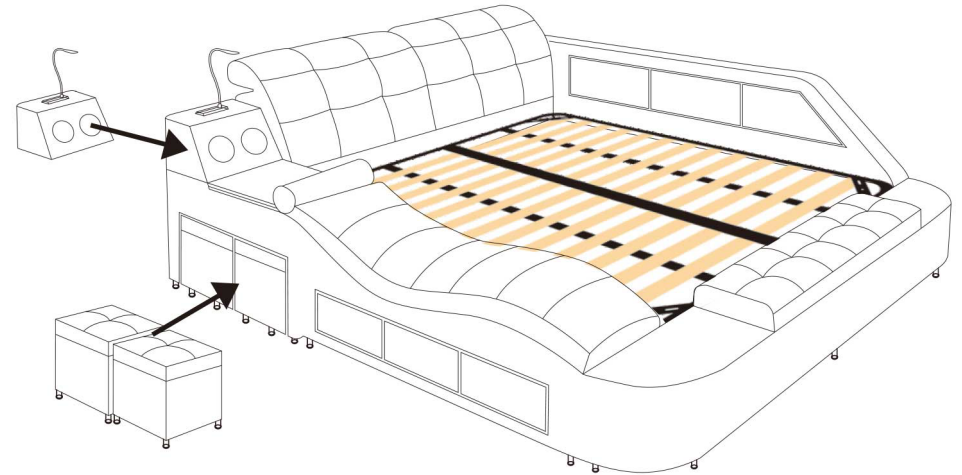

Step6

