

EN:

CAUTION:

- * Before using the chair, ensure that all screws are fully tightened.
- * Retighten all screws every 6 months or as needed.

To remove odor, air the chair outdoors in shade for 1-2 days.



Periodically retighten all screws. Do not use an electric screwdriver.

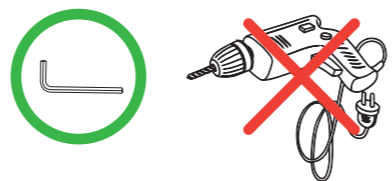

ES:

PRECAUCIÓN:

- * Antes de usar la silla, asegúrese de que todos los tornillos estén bien apretados.
- * Vuelva a apretar todos los tornillos cada 6 meses o cuando sea necesario.

Para eliminar el olor, aeree la silla al aire libre, a la sombra, durante 1-2 días.



Reapriete periódicamente todos los tornillos. No utilice un atornillador eléctrico.

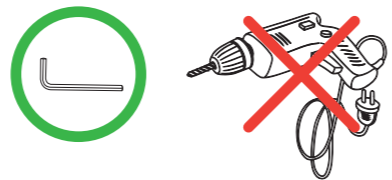

FR:

ATTENTION :

- * Avant d'utiliser la chaise, assurez-vous que tous les vis sont complètement serrés.
- * Resserrez toutes les vis tous les 6 mois ou selon les besoins.

Pour éliminer les odeurs, aérez la chaise à l'extérieur à l'ombre pendant 1 à 2 jours.



Resserrez périodiquement toutes les vis. N'utilisez pas de tournevis électrique.

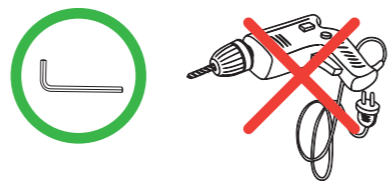

INSTRUCTION MANUAL MANUAL DE INSTRUCCIONES MANUEL D'INSTRUCTIONS

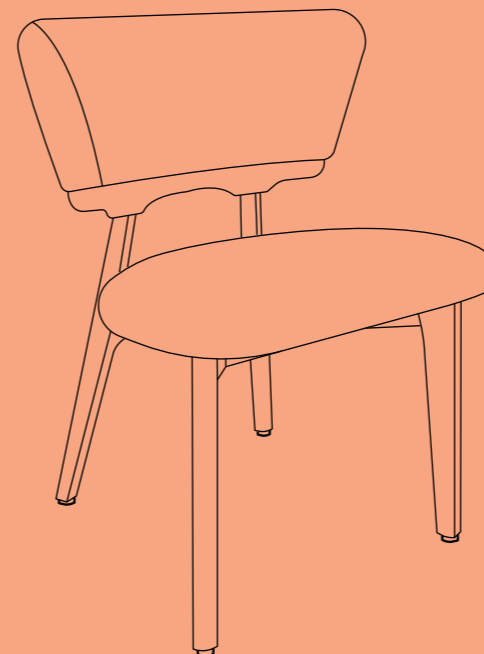

Safety Information / Información de seguridad / Informations relatives à la sécurité

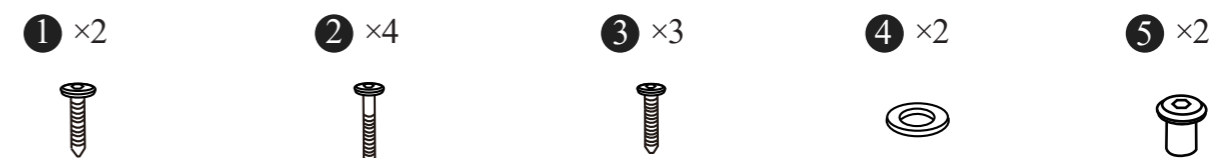
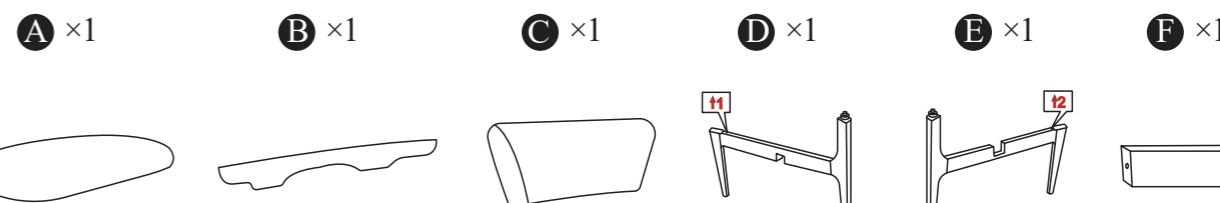

M6*35MM	M6*60MM	M8*45MM	M10*φ18	
---------	---------	---------	---------	--



M6*φ14	M6	M8*φ22	M8	
--------	----	--------	----	--

EN:  : Partially tighten the screws.

 : Fully tighten the screws.

ES:  : Apriete parcialmente los tornillos.

 : Apriete completamente los tornillos.

FR:  : Serrez d'abord les vis partiellement.

 : Serrez les vis complètement.

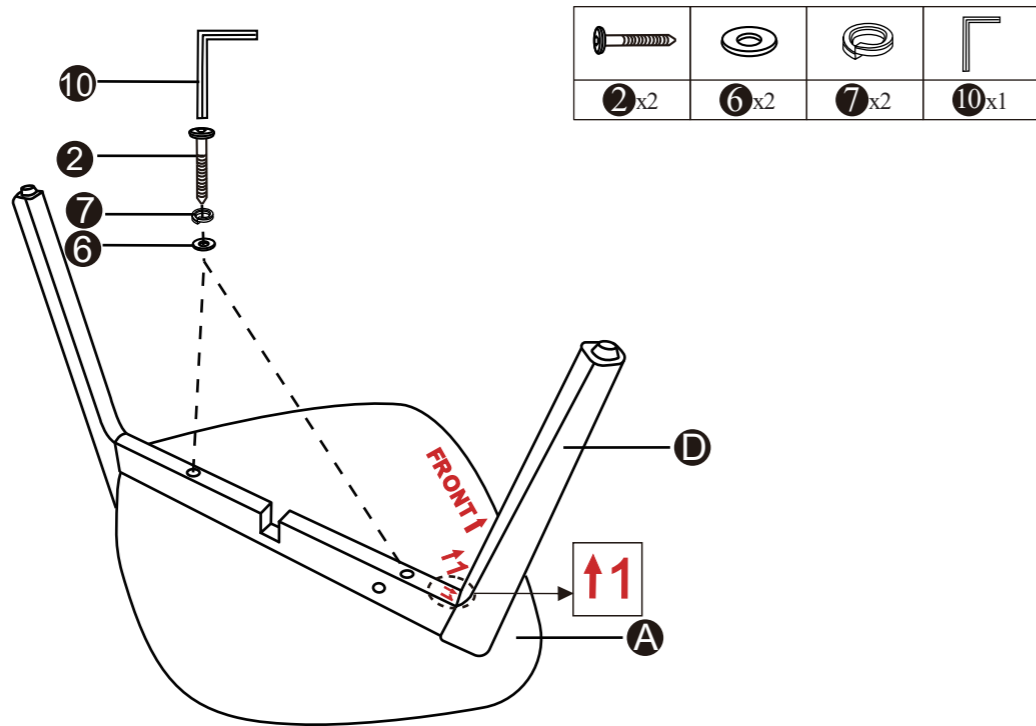
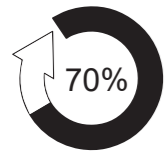

1

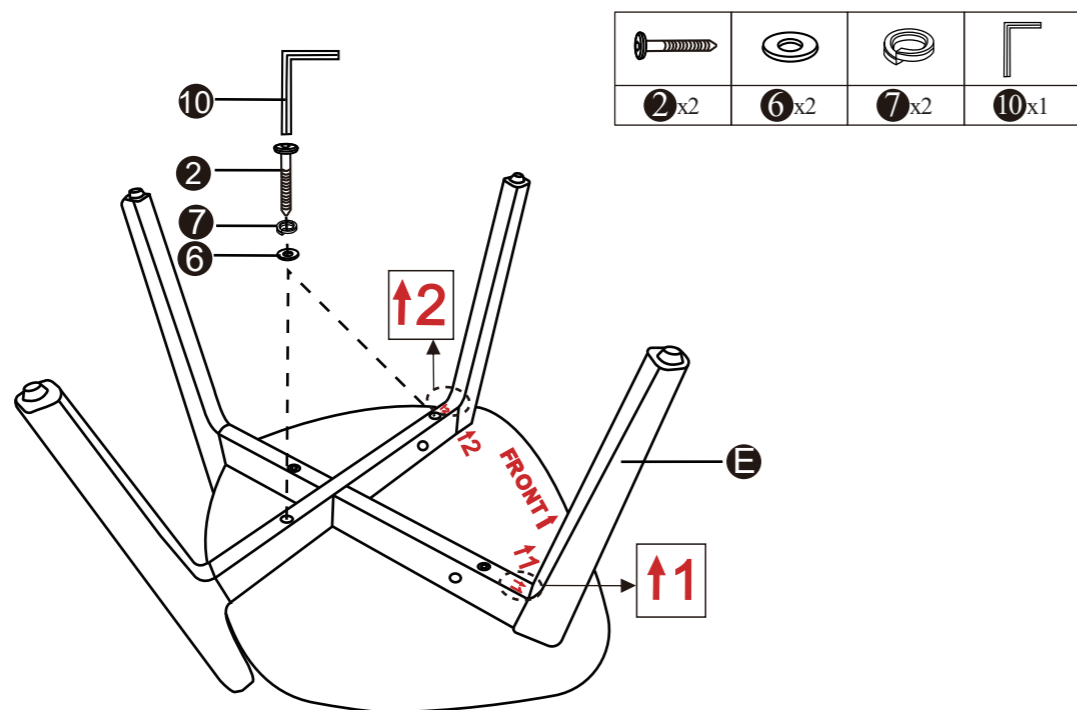
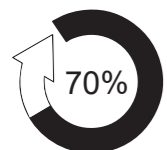

2

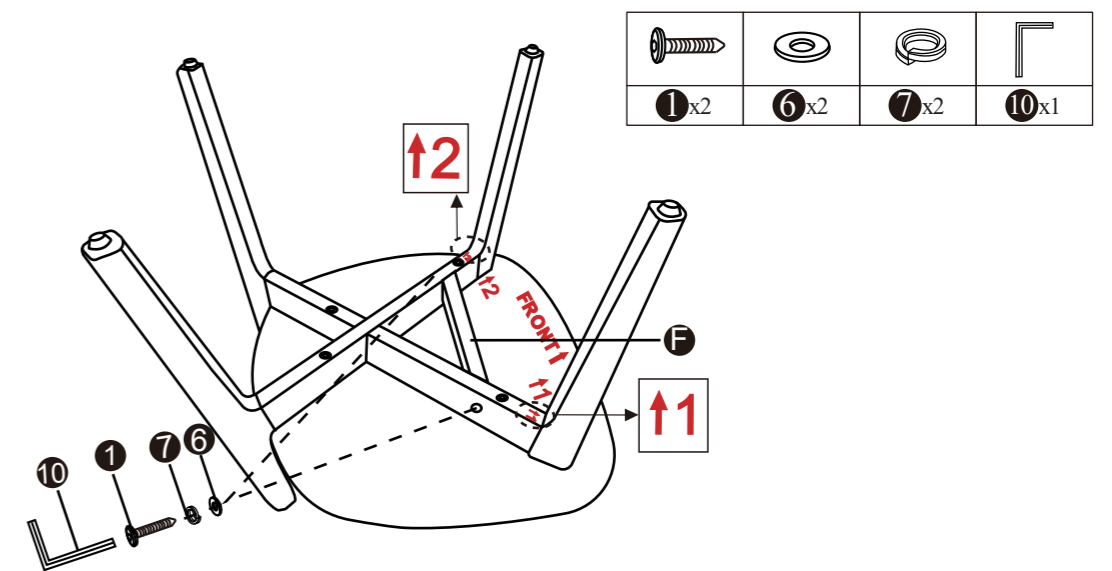
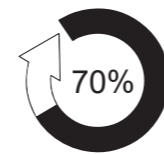

3

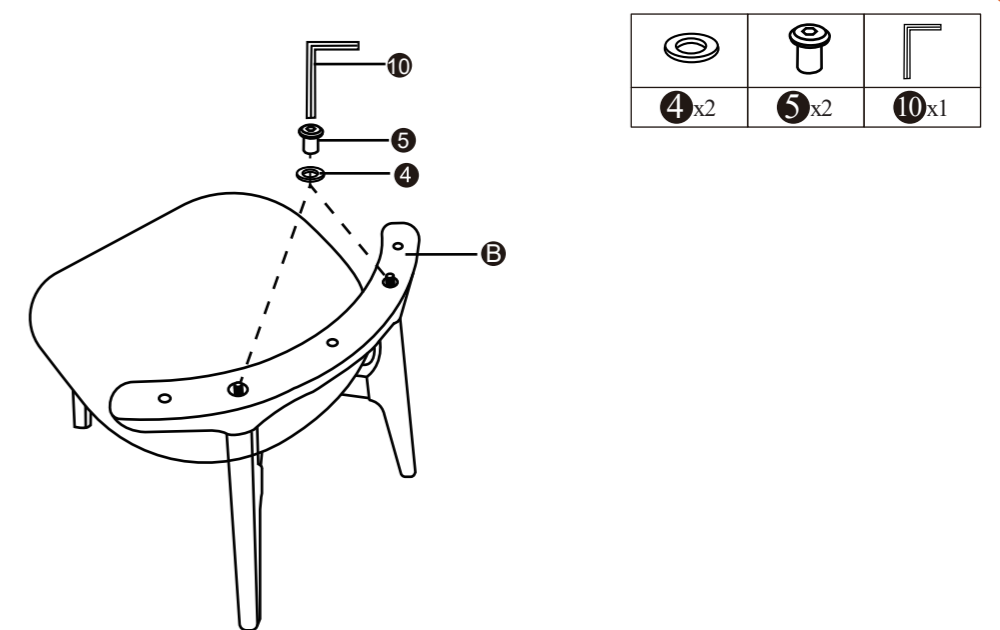

4

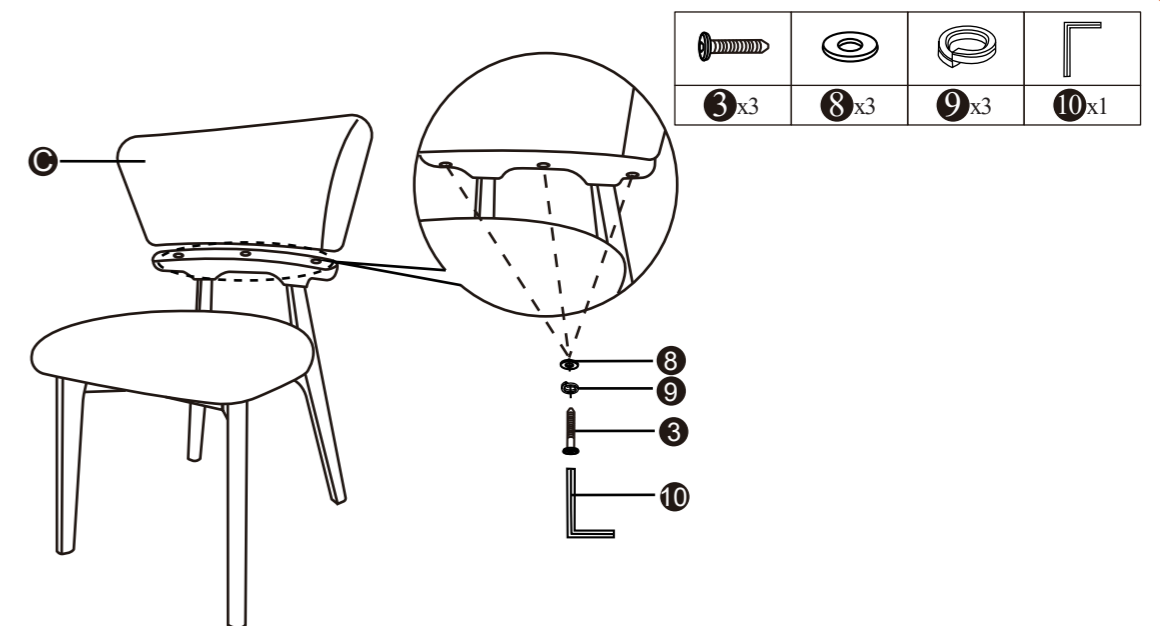

5

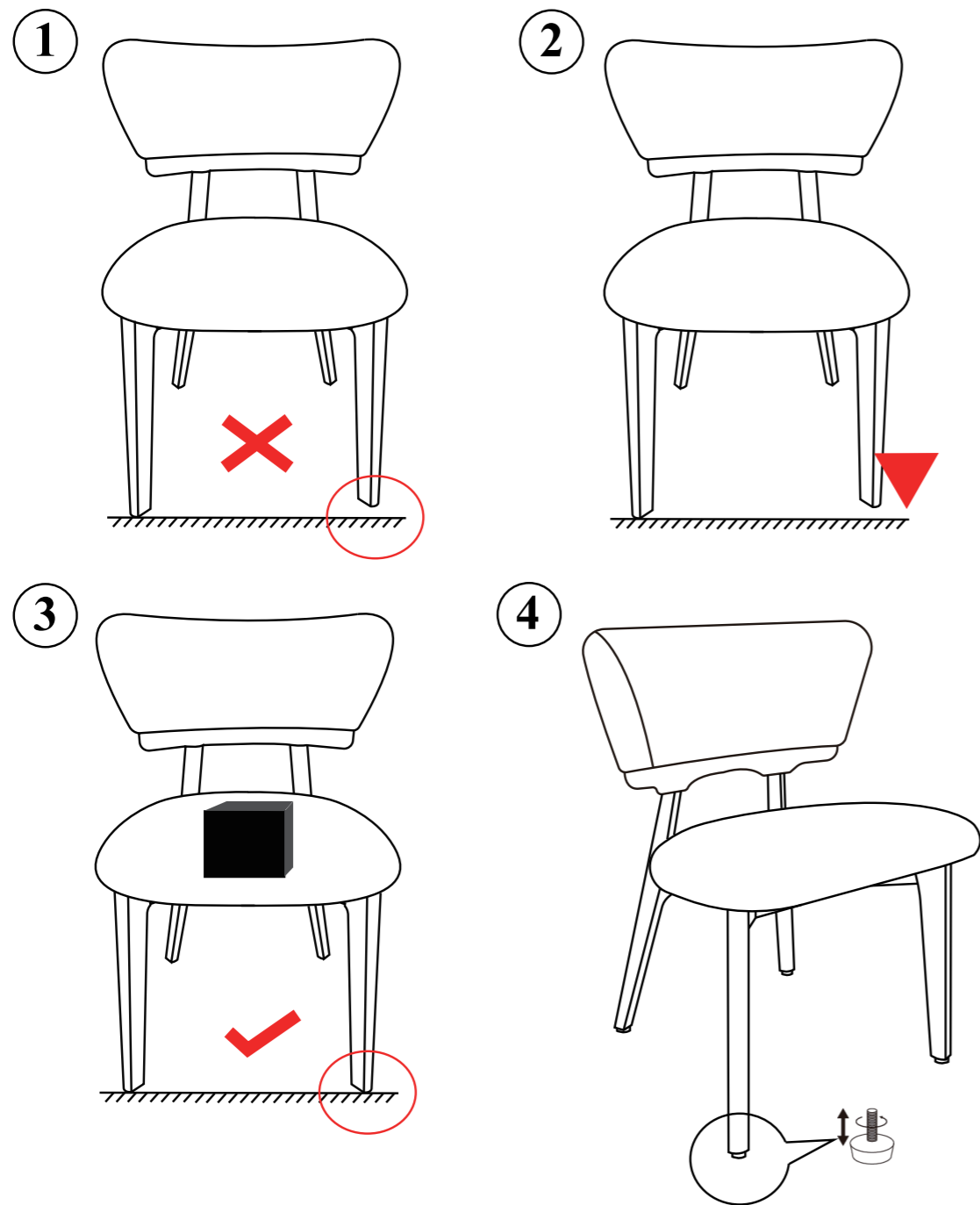

EN: Place an appropriate load on the chair and adjust the feet until it is level and stable.

ES: Coloque una carga adecuada en la silla y ajuste las patas hasta que la silla esté nivelada y estable.

FR: Appliquez une charge appropriée sur la chaise et ajustez les pieds jusqu'à ce qu'elle soit stable et de niveau.

6

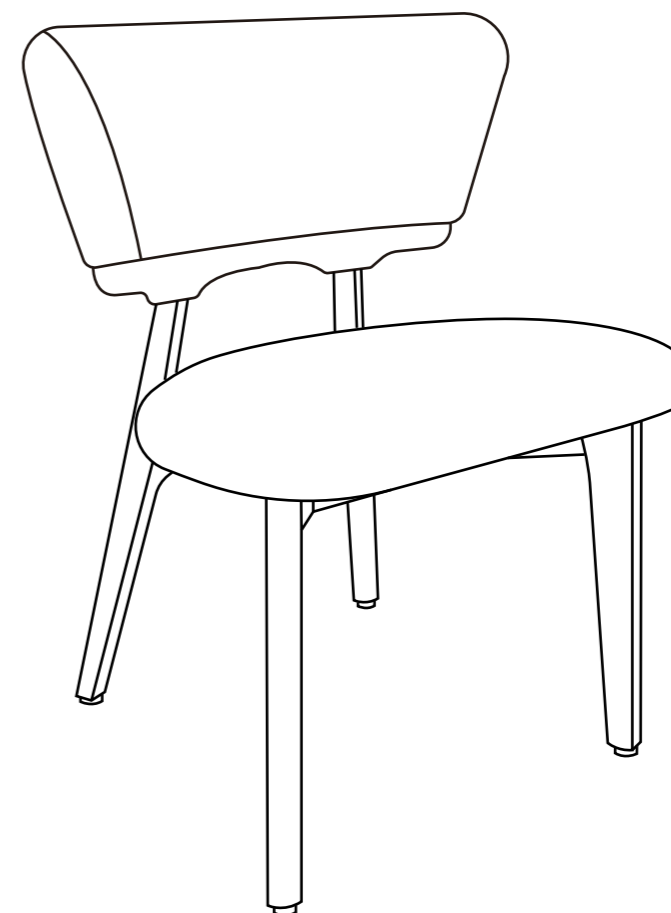

EN: After all parts are in place and the chair is leveled, tighten all screws.

ES: Después de que todas las piezas estén colocadas y la silla esté nivelada, apriete todos los tornillos.

FR: Une fois toutes les pièces en place et la chaise mise à niveau, serrez toutes les vis.

7