

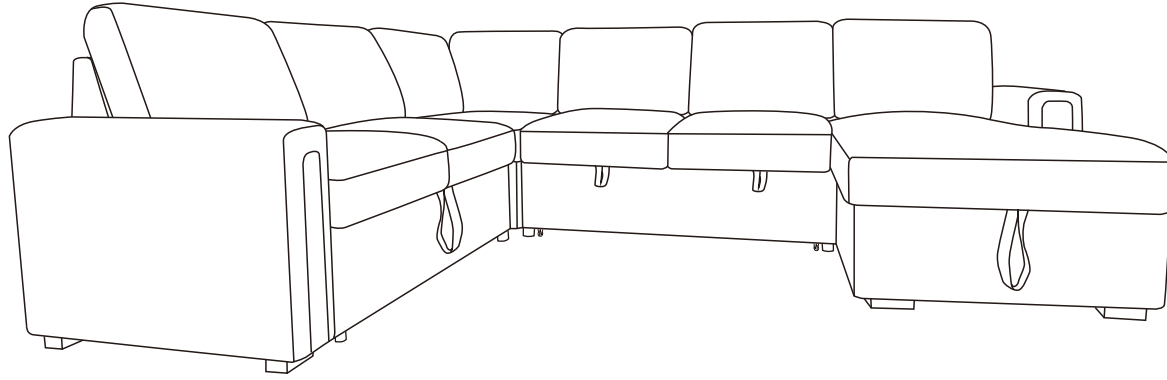

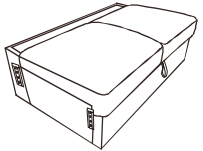

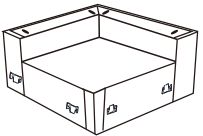

ASSEMBLY INSTRUCTION

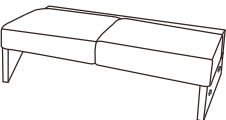
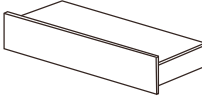
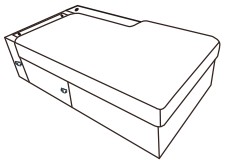
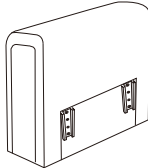
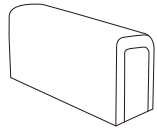





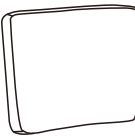
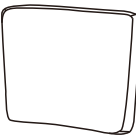
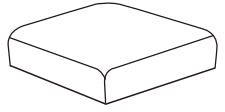

完成图

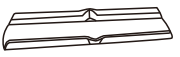

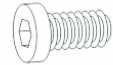
PARTS LIST

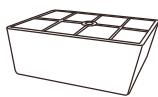
															
A	x1	B	x1	C	x1	D	x1	E	x1	F	x1	G	x1		
															
H	x2	I	x1	J	x1	K	x1	L	x5	M	x1	N	x1	O	x1

HARDWARE LIST

																	
1	x10	2	x14	3	x4	4	M6X25	5	M4	6	x4	7	M8X60	8	M5	9	x18



ASSEMBLY INSTRUCTION

ITEM NO.:

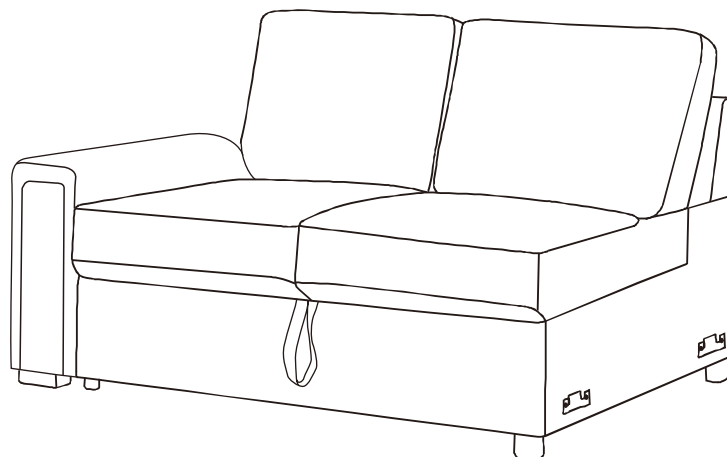



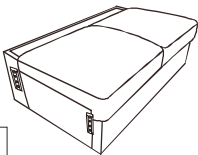
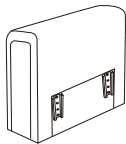

两位储物

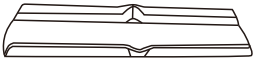

PARTS LIST

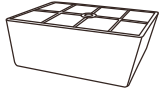
				
A	F	H	L	
x1	x1	x1	x2	

HARDWARE LIST

						
1	2	6	7	8	9	
x4	x2	x2	M8X60 x2	M5 x1	x4	

储物打开，部件展示

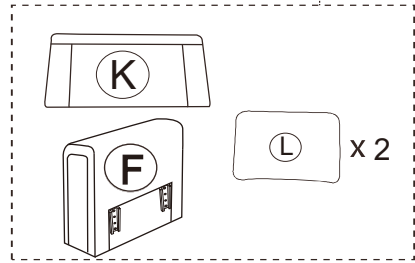
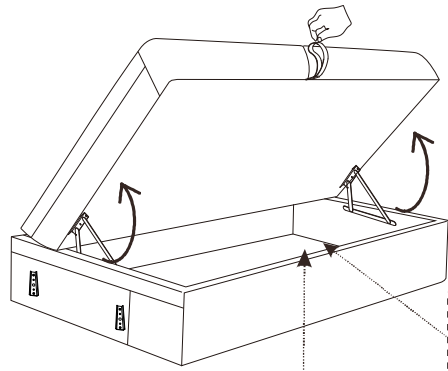

- | | | |
|--|---|----|
| | 1 | x4 |
| | 2 | x2 |
| | 6 | x2 |
| | 7 | x2 |
| | 8 | x1 |
| | 9 | x4 |

Step1

两位储物
塑胶圆胶脚加上防滑垫片
对准四个底部孔位，
向右旋转进孔位，
胶脚组装完成

扶手
M8*60螺杆塞进胶脚中间孔位，
加上防滑垫片，
对准扶手底部孔位，
用M5扳手旋转至固定

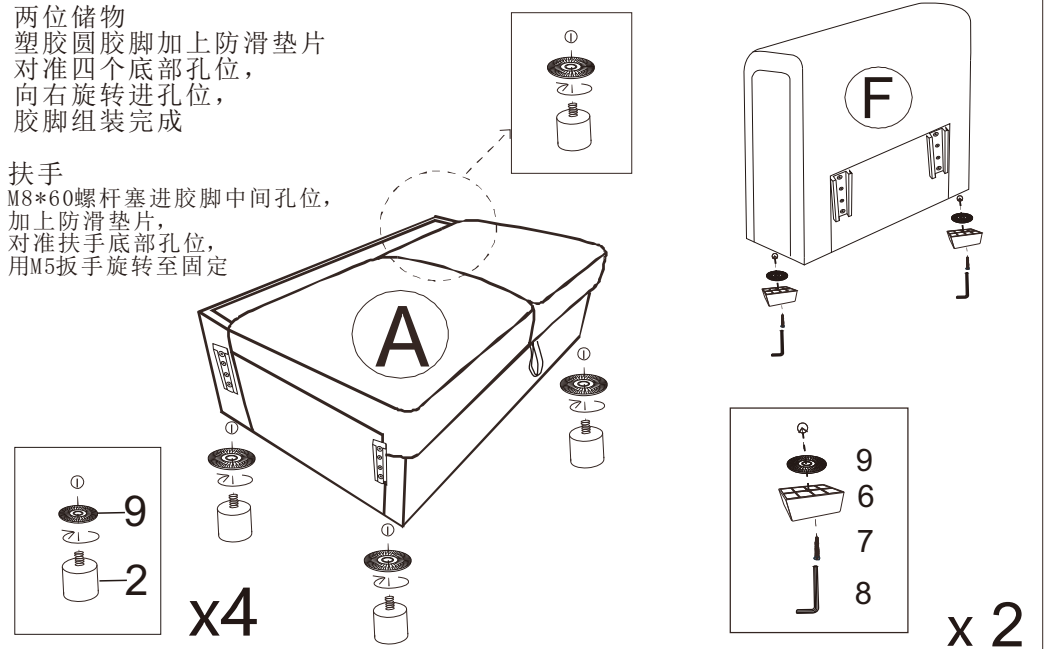

Step2

两位储物扶手，U型插销，
扶手部件向两位储物对准U型插销，
下插至紧密

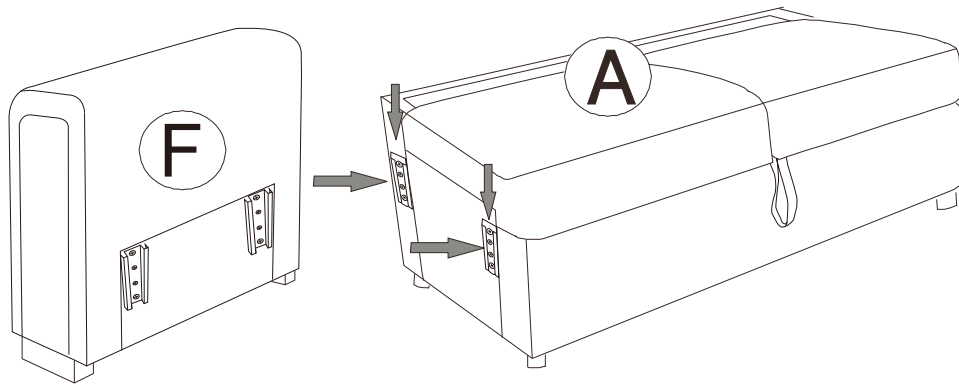

Step3

五金双头插，先插上拼架，
对准坐架孔位，下插至紧密

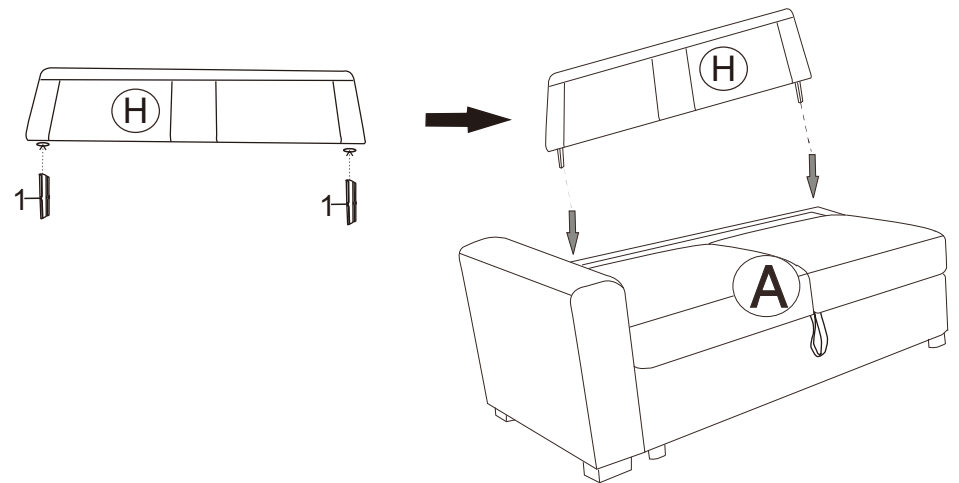

Step4

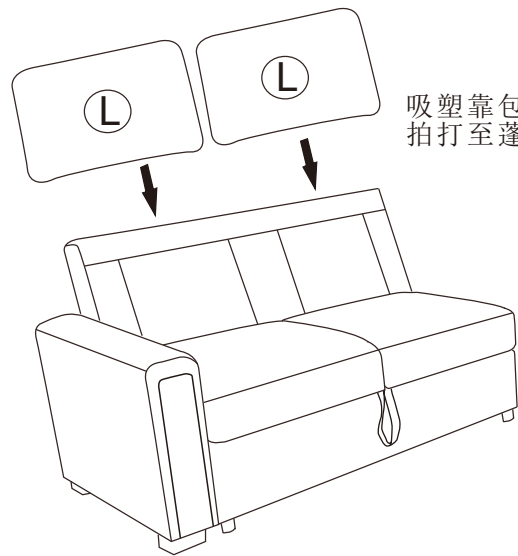
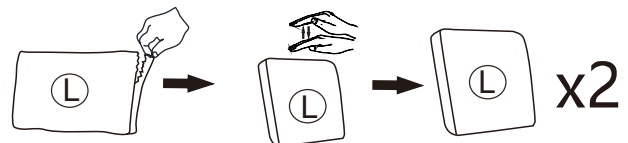

吸塑靠包，需先撕开包装，
拍打至蓬松，放至靠背上

Step5

两位储物完成图

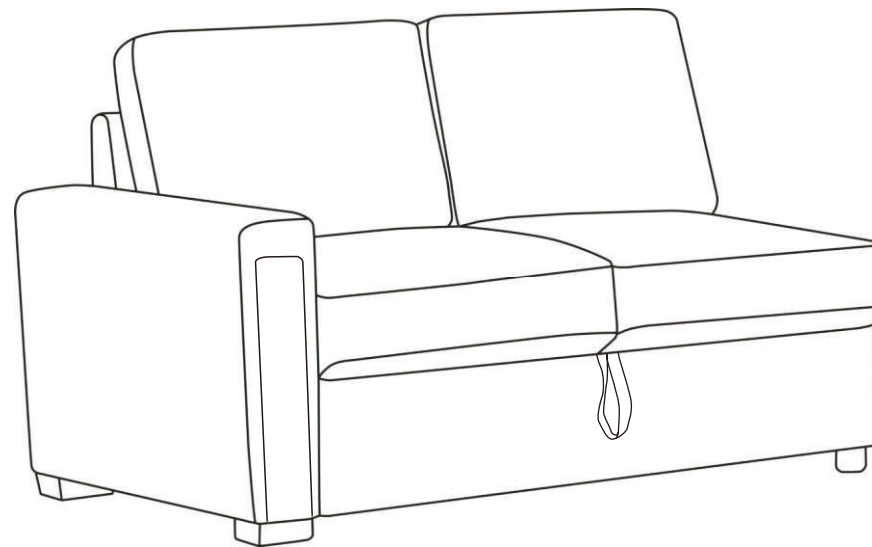

两位储物和转角位组装，
山插片 转角位坐架山插片
对准
两位储物坐架山插片向下插至紧密

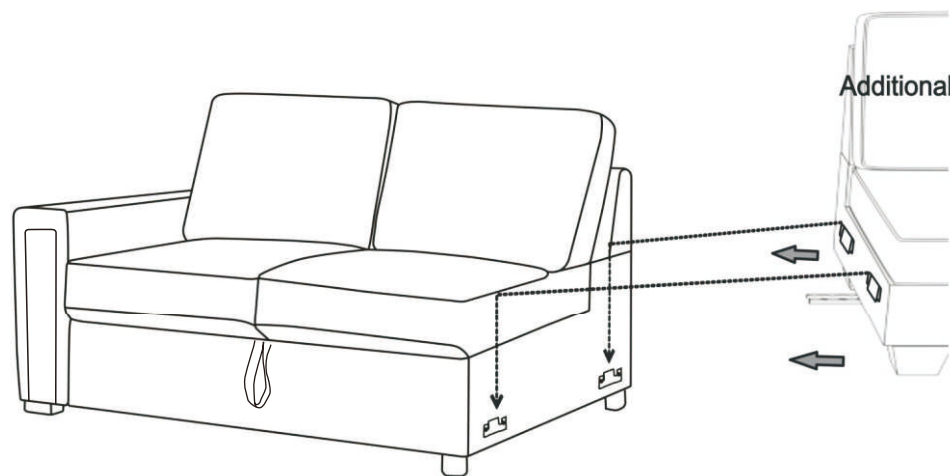

ASSEMBLY INSTRUCTION

ITEM NO.:

转角部位完成图

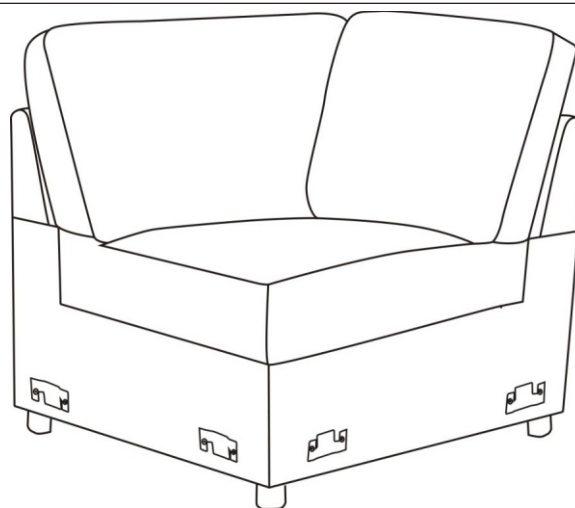

PARTS LIST

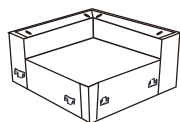

B

x1



I

x1



J

x1



M

x1



N

x1

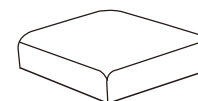

O

x1

HARDWARE LIST



1

x4

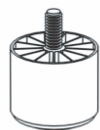

2

x4



9

x4

坐架底部拉链拉开，
部件展示

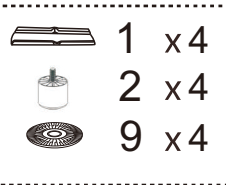
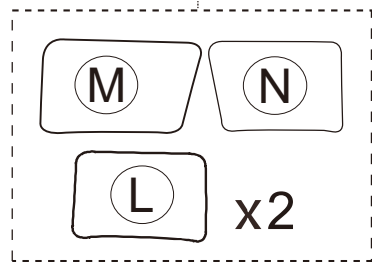
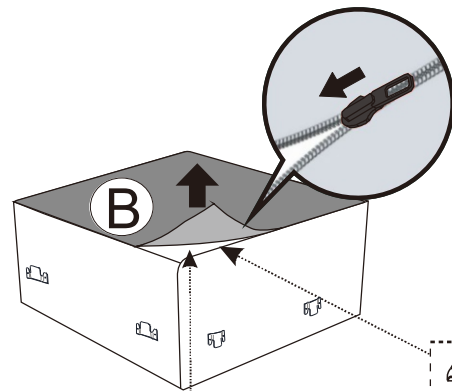

Step1

塑胶圆胶脚加上防滑垫片
对准四个底部孔位，
向右旋转进孔位，
胶脚组装完成

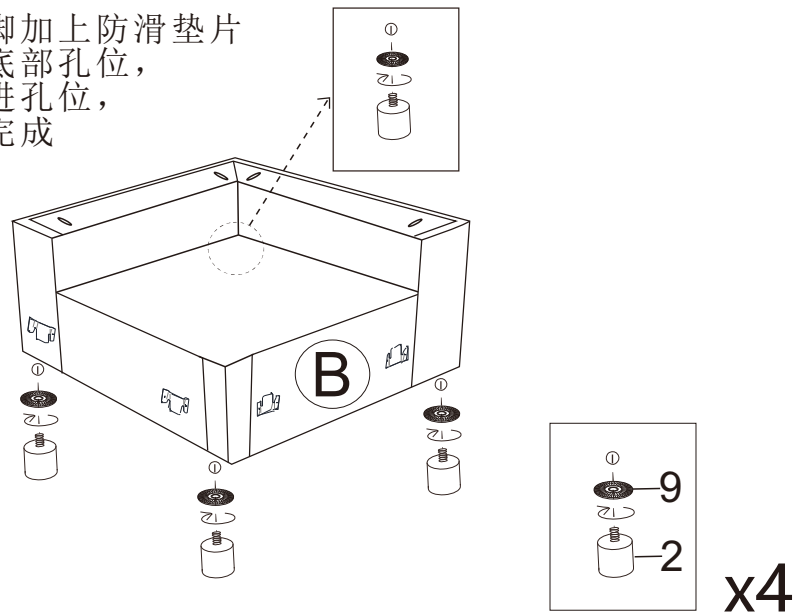

Step2

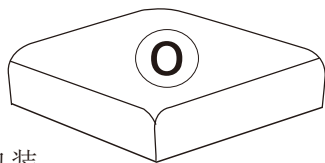
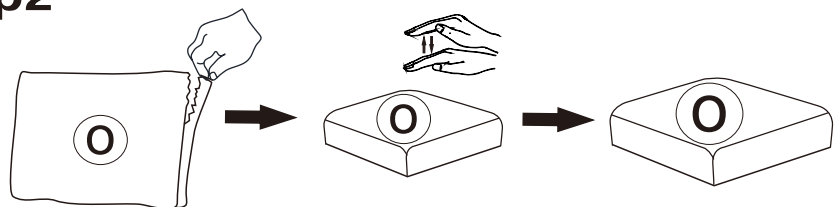

吸塑坐垫，需先撕开包装，
拍打至蓬松，放至坐架上

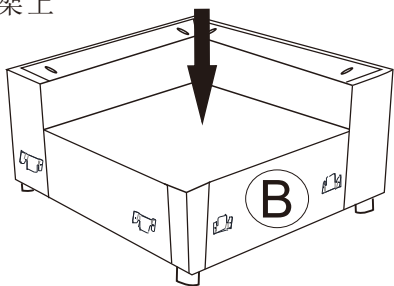

Step3

五金双头插，先插上拼架，
对准坐架孔位，下插至紧密

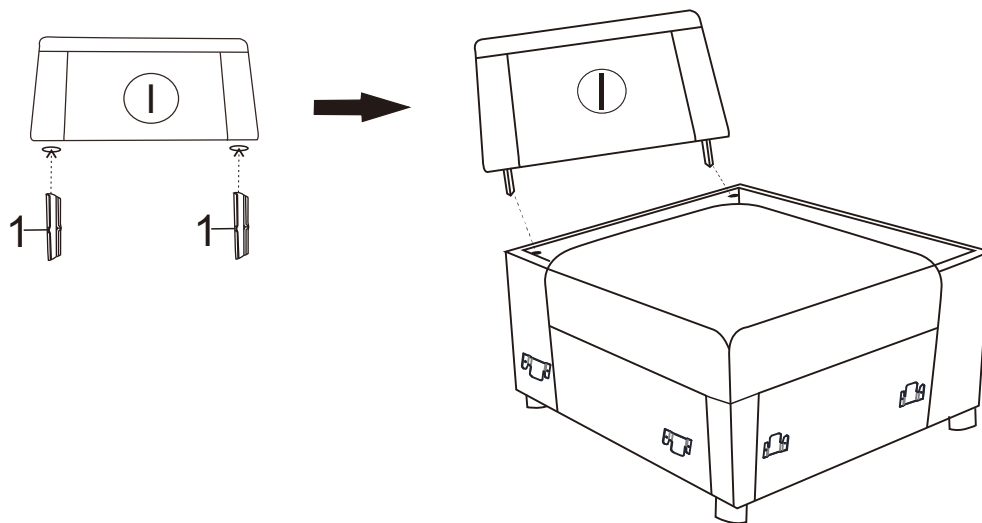

Step4

五金双头插，先插上拼架，
对准坐架孔位，下插至紧密

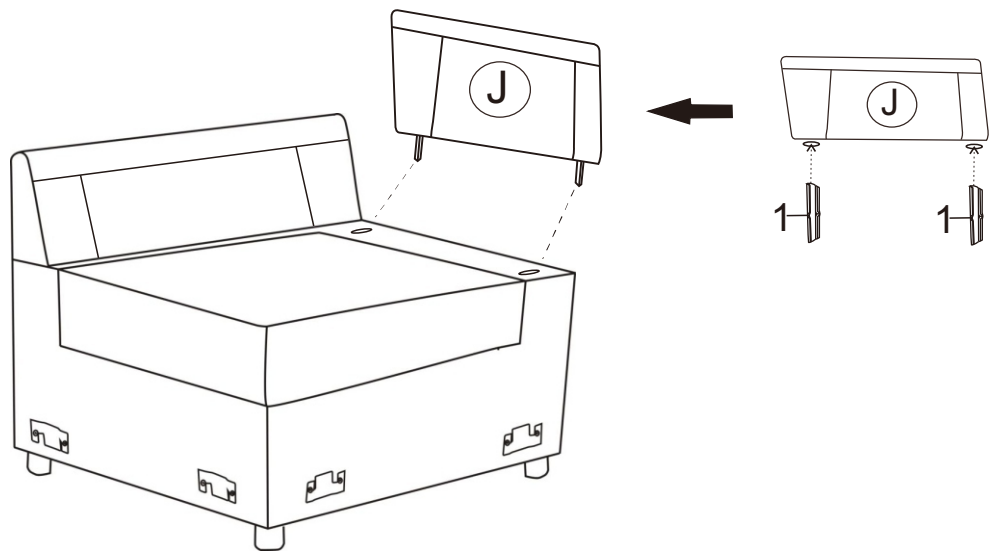

Step5

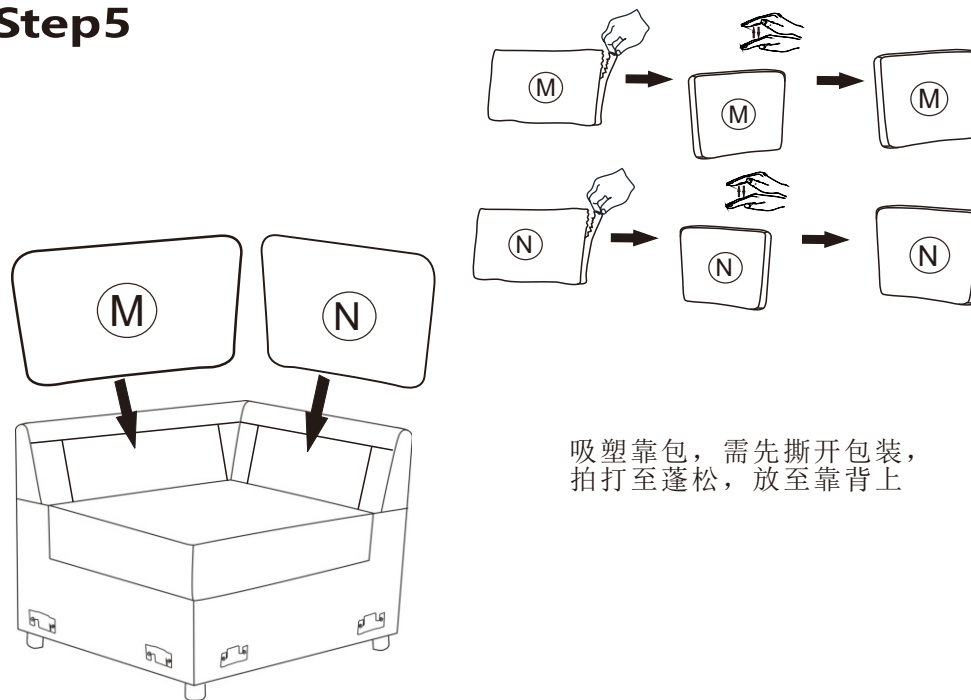

Step6

转角位完成图

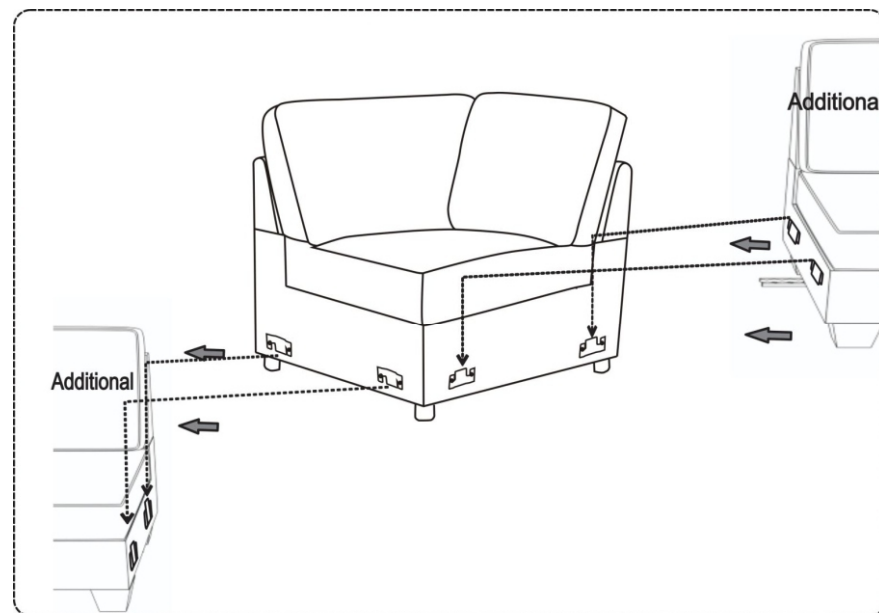
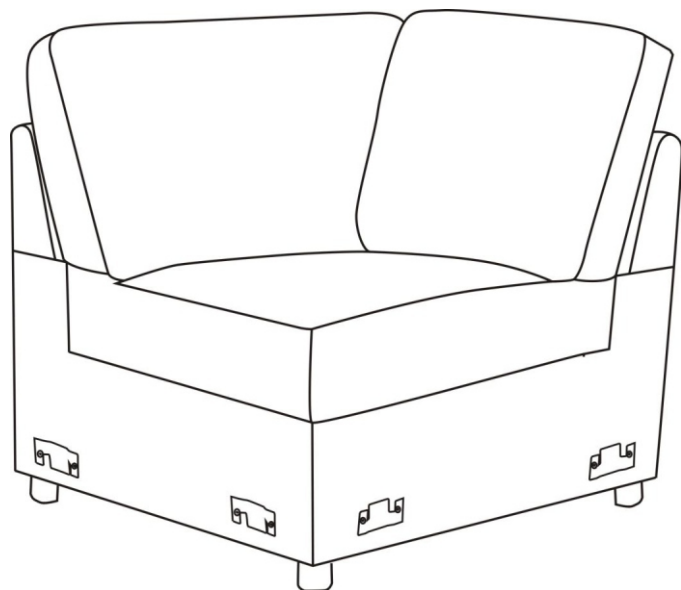

ASSEMBLY INSTRUCTION

ITEM NO.:

两位拉床

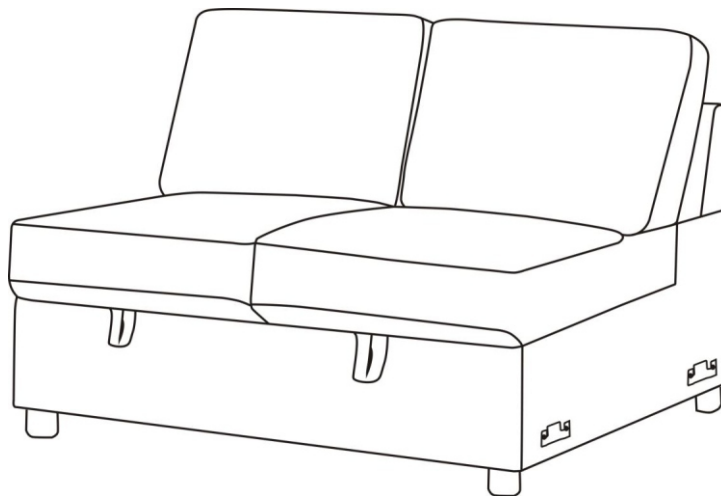

PARTS LIST

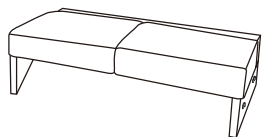

C

x1

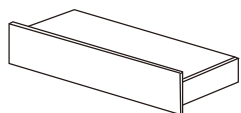

D

x1



H

x1

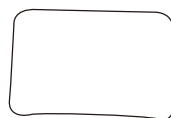

L

x2

HARDWARE LIST

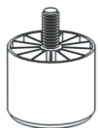

2

x4



3

x4



4

x8



M4

5

x1



9

x4

坐架底部，部件展示

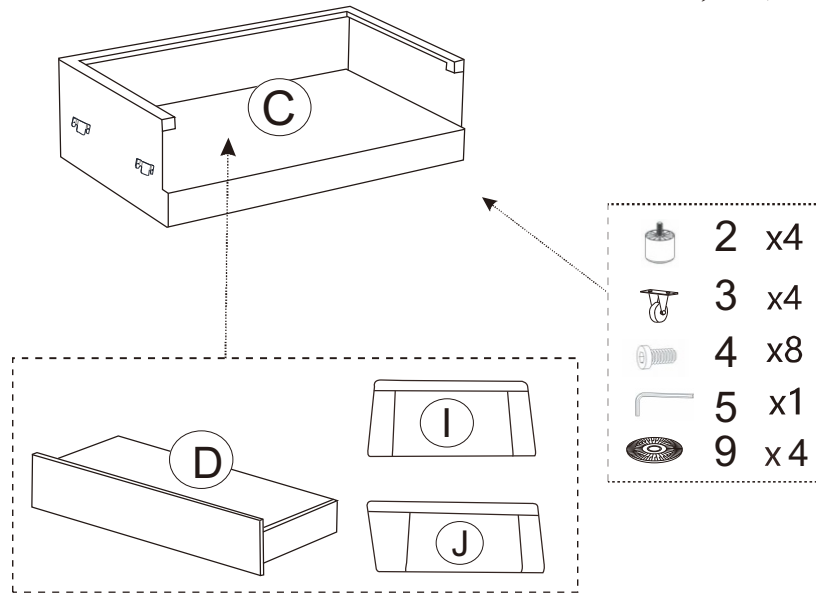

Step1

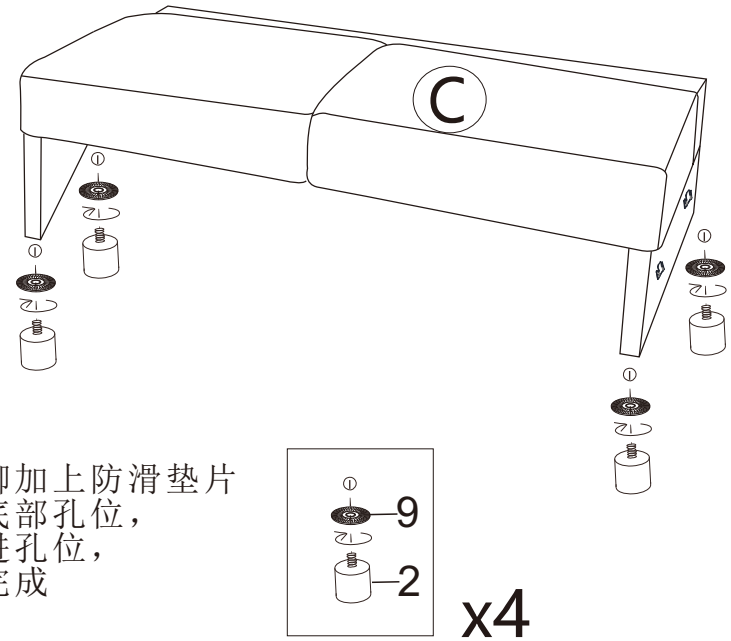

Step2

拖床底部四个轮子
用M4扳手旋转螺杆
对准底部孔位固定轮子

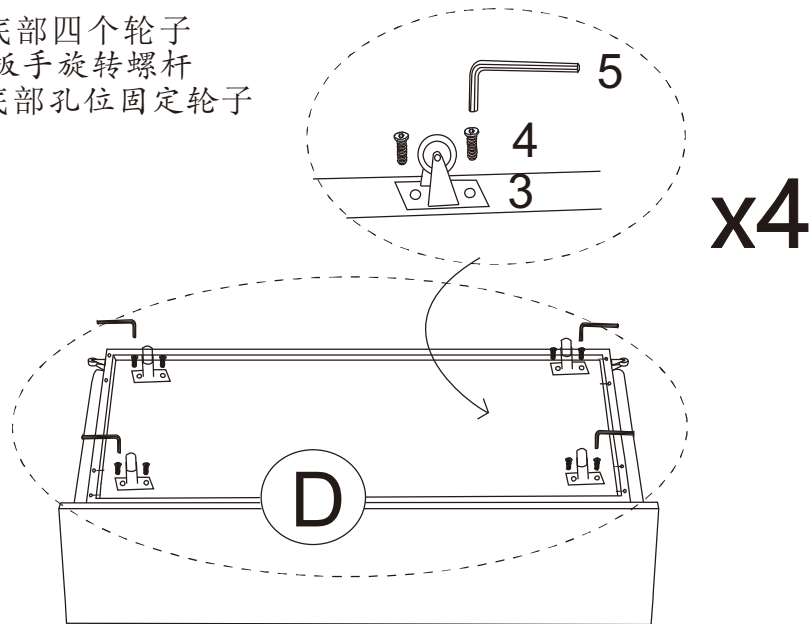

Step3

拖床上抬推进坐架底部

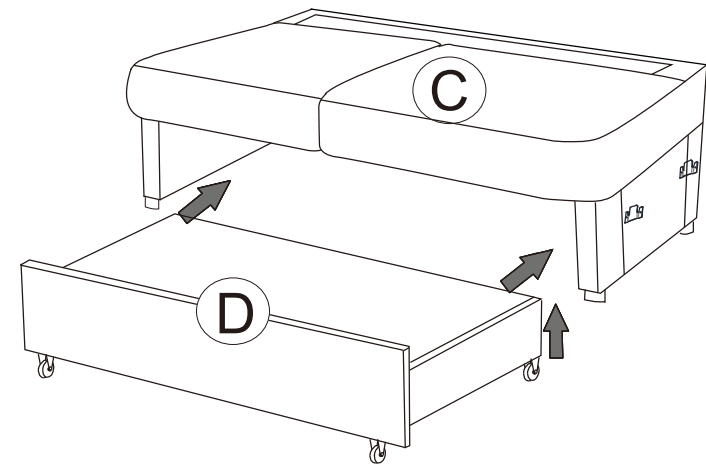

Step4

五金双头插，先插上拼架，
对准坐架孔位，下插至紧密

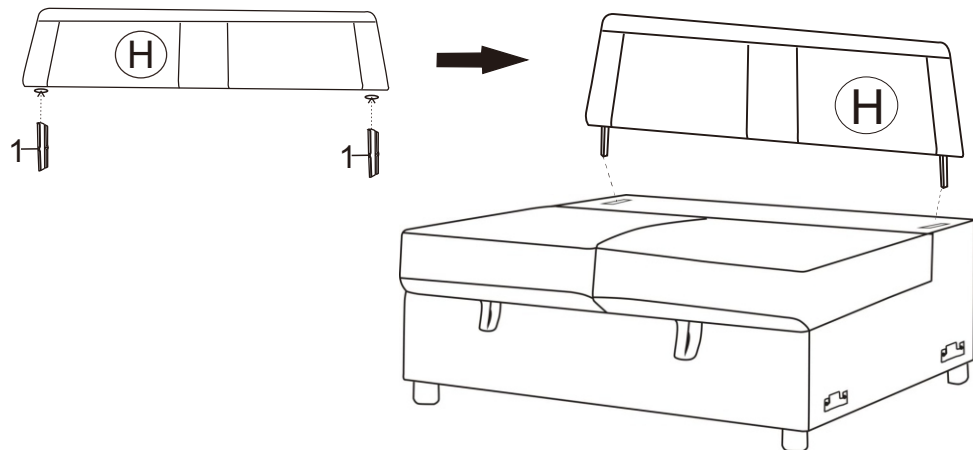

Step5

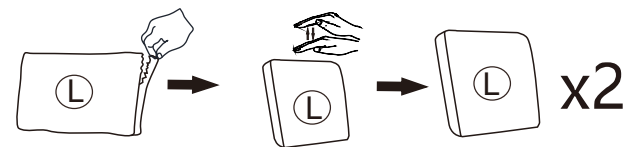

吸塑靠包，需先撕开包装，
拍打至蓬松，放至靠背上

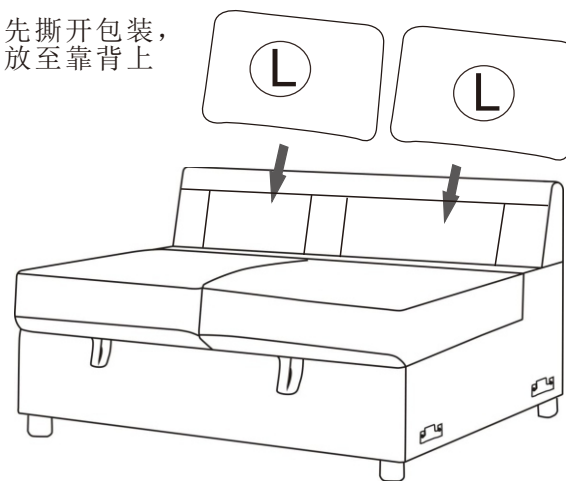

Step6

两位拉床展示完成图

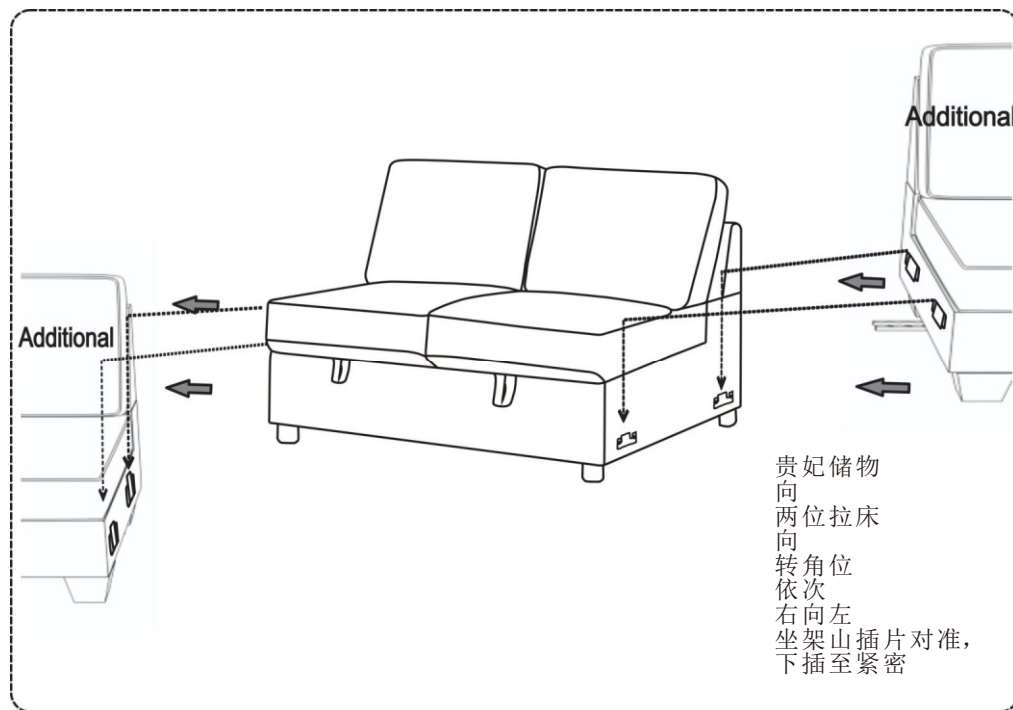
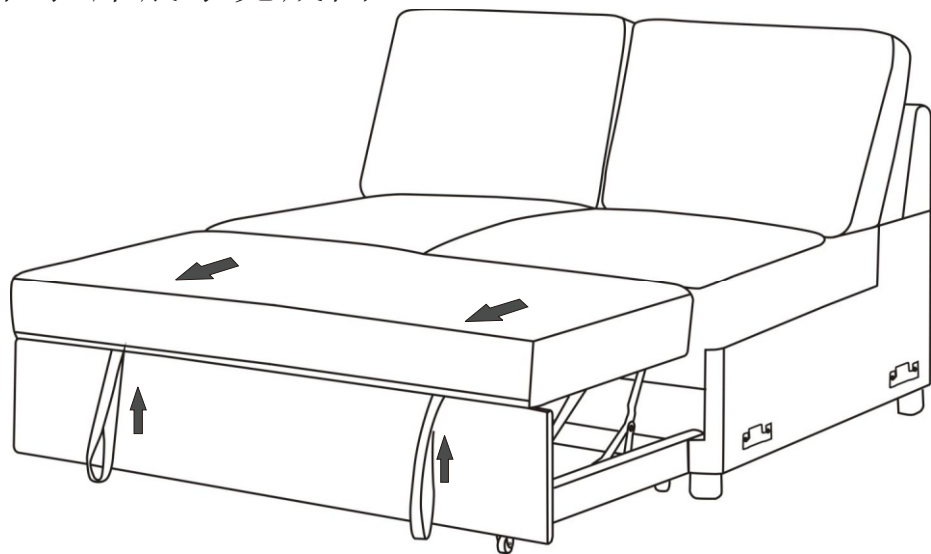



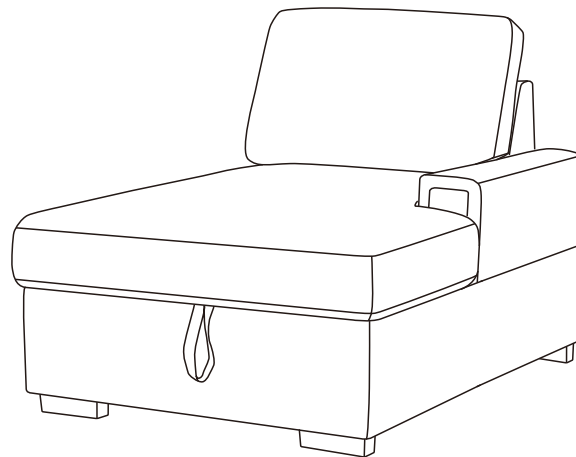

ASSEMBLY INSTRUCTION

ITEM NO.:



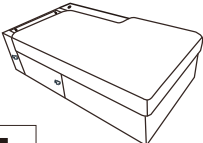

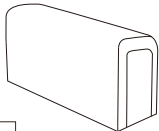

储物贵妃

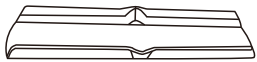

PARTS LIST

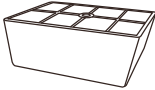
				
E x1	K x1	G x1	L x1	

HARDWARE LIST

			 M8X60	 M5		
1 x4	2 x2	6 x2	7 x2	8 x1	9 x4	

贵妃打开，内部部件展示图

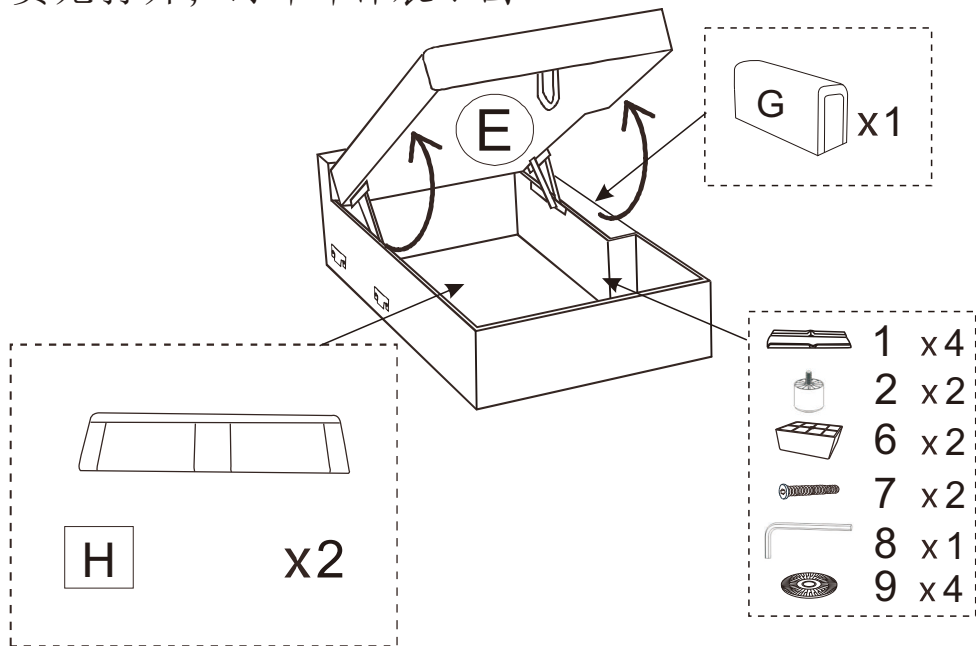

Step1

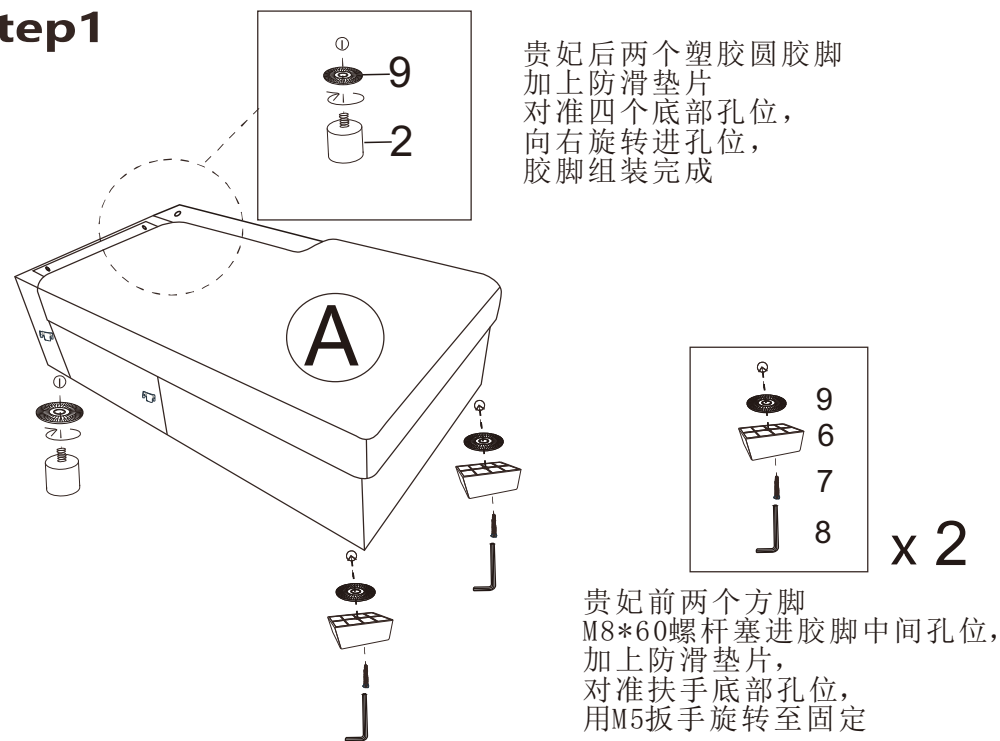

Step2

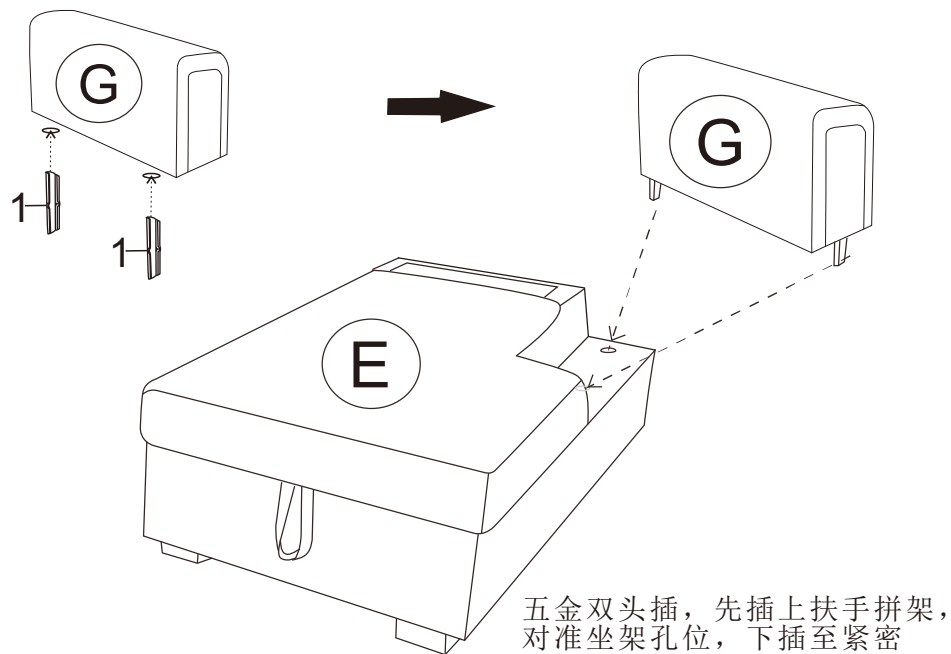

Step3

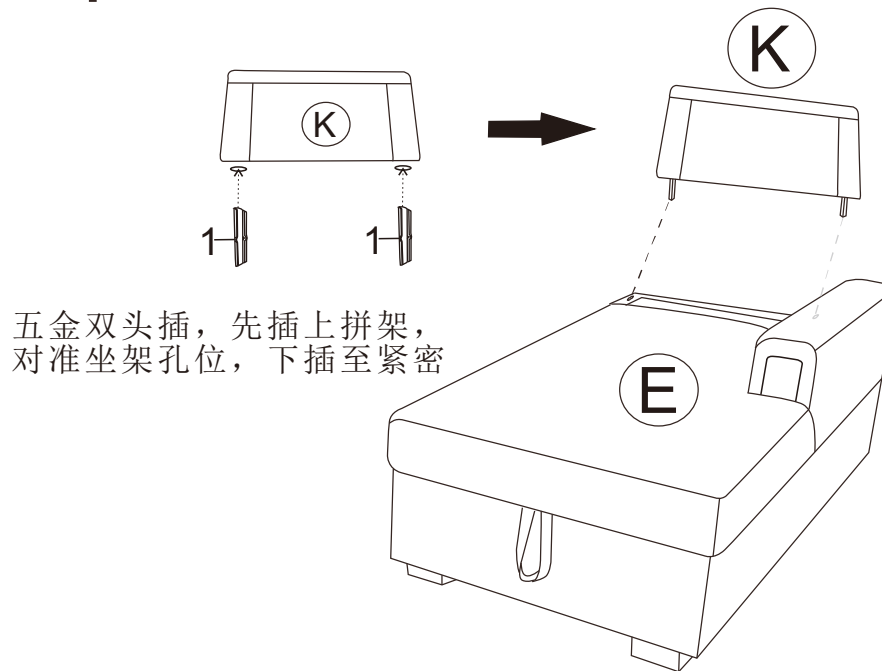

Step4

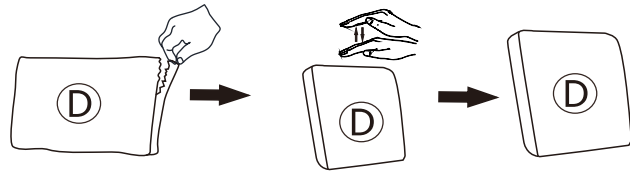

吸塑靠包，需先撕开包装，
拍打至蓬松，放至靠背上

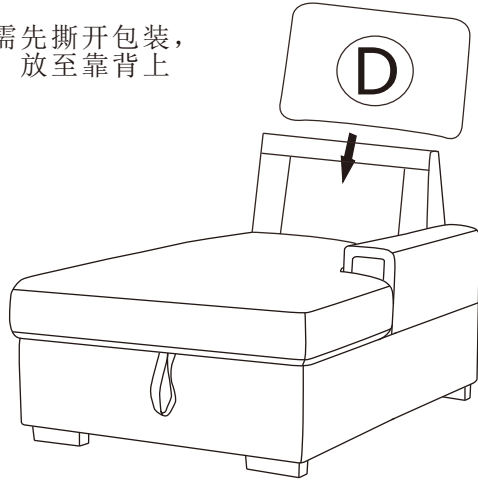

Step5

贵妃储物完成图

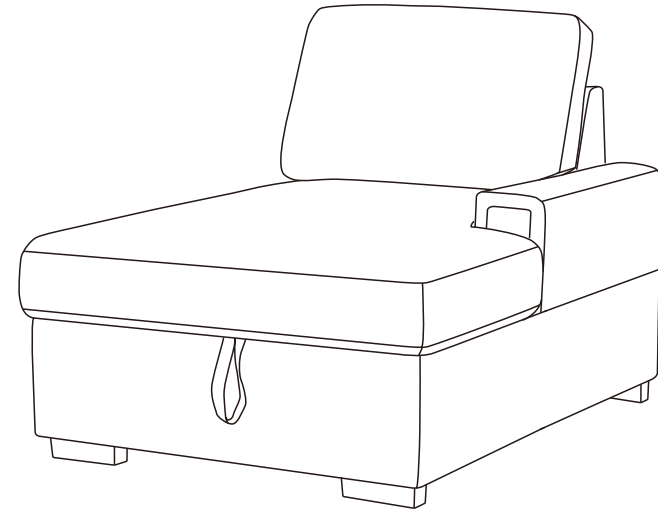

贵妃储物和两位拉床组装，
贵妃坐架山插片对准两位拉床坐架山插片
下插至紧密

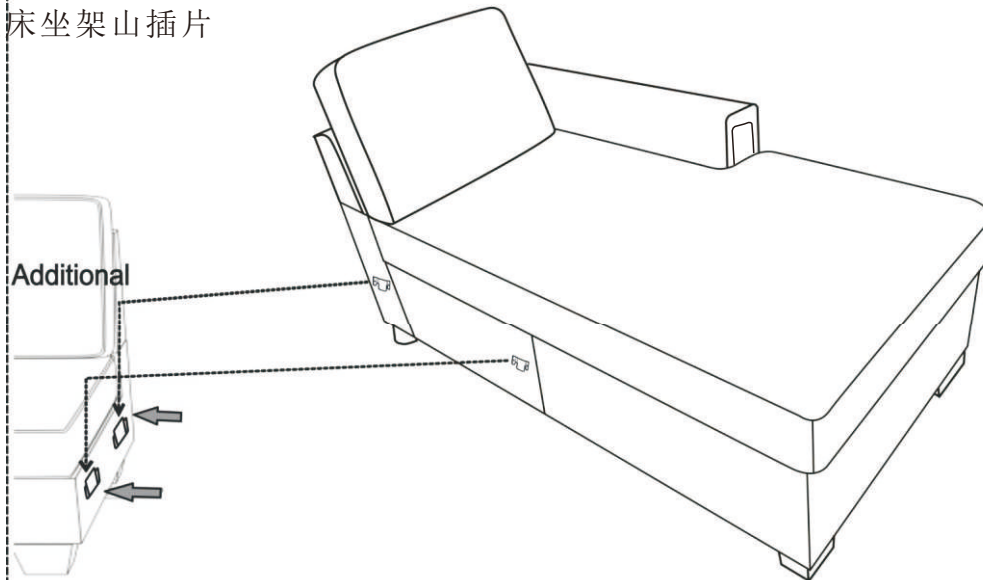

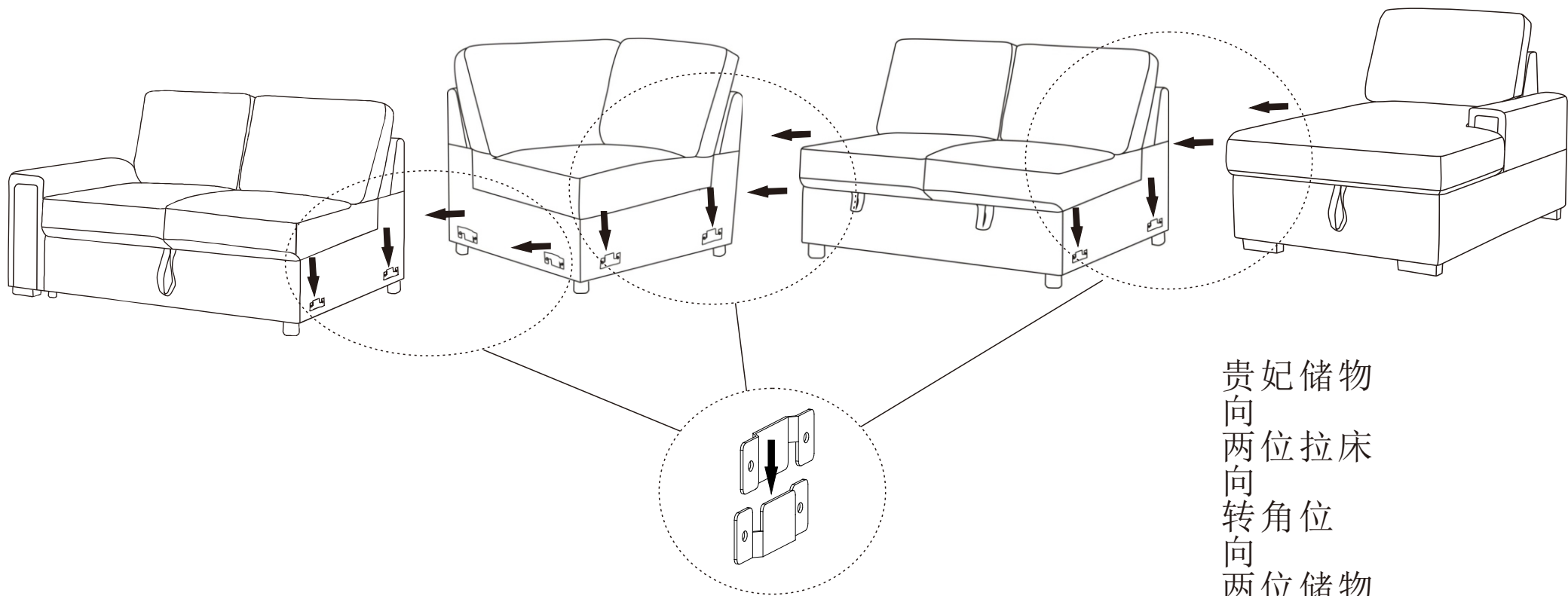

贵妃储物
 向两位拉床
 向角位
 转角位
 向两位储物
 依次
 右向左
 坐架山插片对准，
 下插至紧密