

# VEVOR

**Affordable. Reliable. Home Improvement.**

## **LEATHER BEDROOM BENCHES**

**MODEL: CWD0112CA-KD-BROWN**

**CWD0112CA-KD-BLACK**

**CWD0112CA-KD-GRAY**

Leather bedroom benches installation guide:

<https://youtu.be/nUzj1oz2RuM>



# VEVOR

Affordable. Reliable. Home Improvement.

## LEATHER BEDROOM BENCHES

**MODEL: CWD0112CA-KD-BROWN**

**CWD0112CA-KD-BLACK**

**CWD0112CA-KD-GRAY**

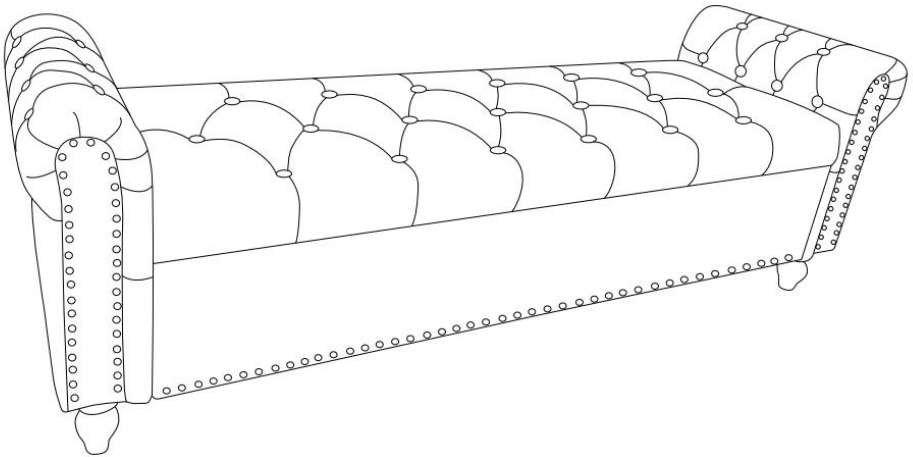

This is the original instruction, please read all manual instructions carefully before operating. VEVOR reserves a clear interpretation of our user manual. The appearance of the product shall be subject to the product you received. Please forgive us that we won't inform you again if there are any technology or software updates on our product.

## **SAFETY INSTRUCTIONS**

### **WARNING:**

**Read this material before using this product. Failure to do so may result in serious injury.**

### **Assembly precautions**











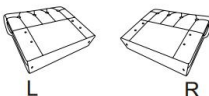
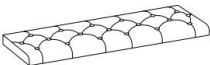

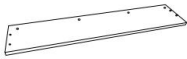

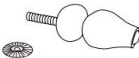
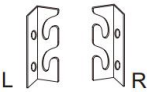
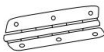





1. Assemble only according to these instructions. Improper assembly may create hazards.
2. Wear ANSI-approved safety goggles and heavy-duty work gloves during assembly.
3. Keep the assembly area clean and well-lit.
4. Keep bystanders out of the area during assembly.
5. Do not assemble if tired or when under the influence of alcohol, drugs or medication.
6. The product capabilities apply to properly and completely assembled products only.
7. Assemble on a flat, level, hard and smooth surface capable of safely supporting the Leather Bedroom Benches.
8. If possible, you can use power tools to make assembly easier.
9. For additional information regarding the parts listed in the following pages, please refer to the Assembly Diagram of this manual. Unwrap and separate all parts in a clean work area.

### **Use precautions**

1. Do not exceed specified weight capacities.
2. Use only on a flat, level, hard, and smooth surface that can safely support a fully loaded Leather Bedroom Benches.
3. Use as intended only.
4. Inspect before every use; do not use if parts are loose or damaged.

**SAVE THIS MANUAL**

# PARTS LIST

<p>Ax1</p> 	<p>Bx1</p> 	<p>Cx1</p> 	<p>Dx1</p> 			
<p>Ex1</p> 	<p>Fx4</p> 	<p>Gx2</p> 	<p>Hx3</p> 			
<p>Jx8</p> 	<p>Kx16</p>  <p>M8*25mm</p>	<p>Mx8</p>  <p>M6*20mm</p>	<p>Nx26</p>  <p>M4*25mm</p>			
<p>Ox1</p> 	<p>Zx1</p> 	<p>Spare Parts</p> <table border="1" style="width: 100%; text-align: center;"> <tbody> <tr> <td data-bbox="561 751 710 842"> <p>Kx2</p>  </td> <td data-bbox="710 751 885 842"> <p>Mx1</p>  </td> <td data-bbox="885 751 1036 842"> <p>Nx2</p>  </td> </tr> </tbody> </table>		<p>Kx2</p> 	<p>Mx1</p> 	<p>Nx2</p> 
<p>Kx2</p> 	<p>Mx1</p> 	<p>Nx2</p> 				

# ASSEMBLY STEP

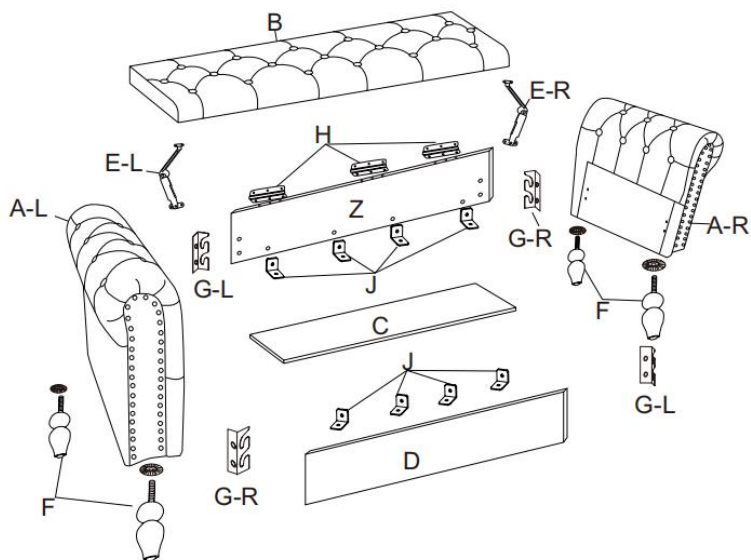

## STEP 1

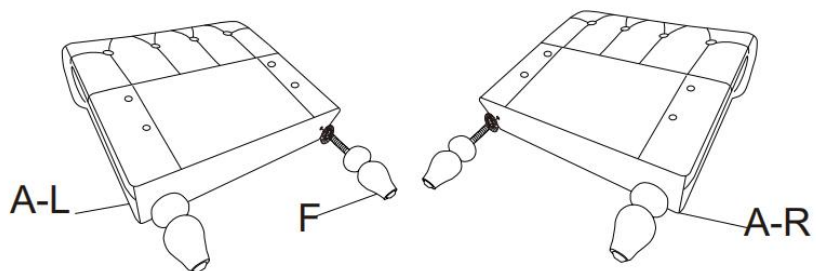

## STEP 2

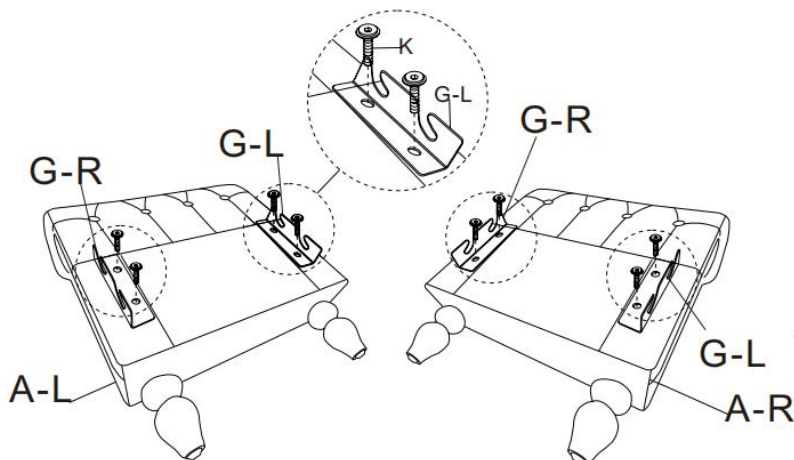
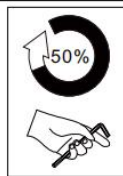

## STEP 3

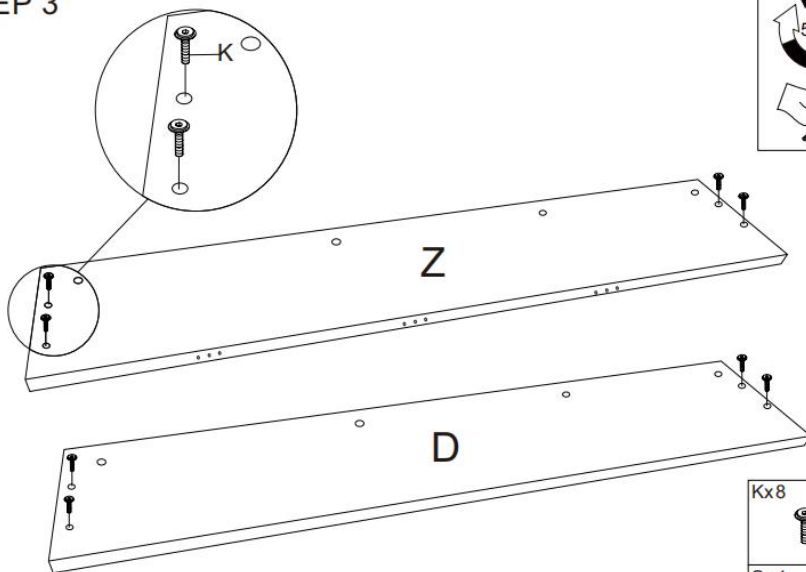
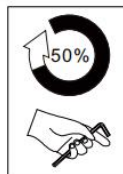

## STEP 4

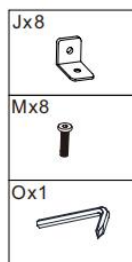
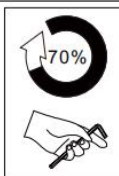
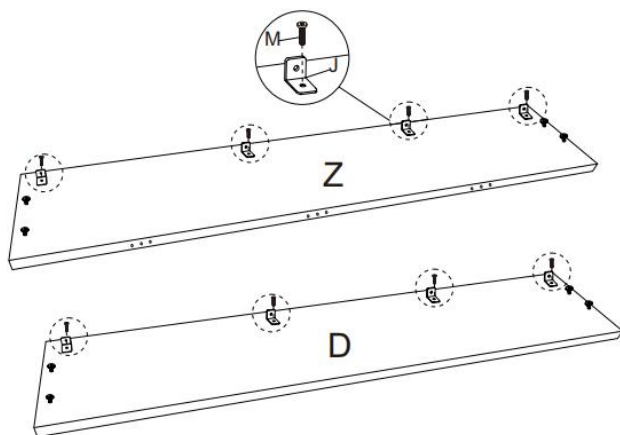

## STEP 5

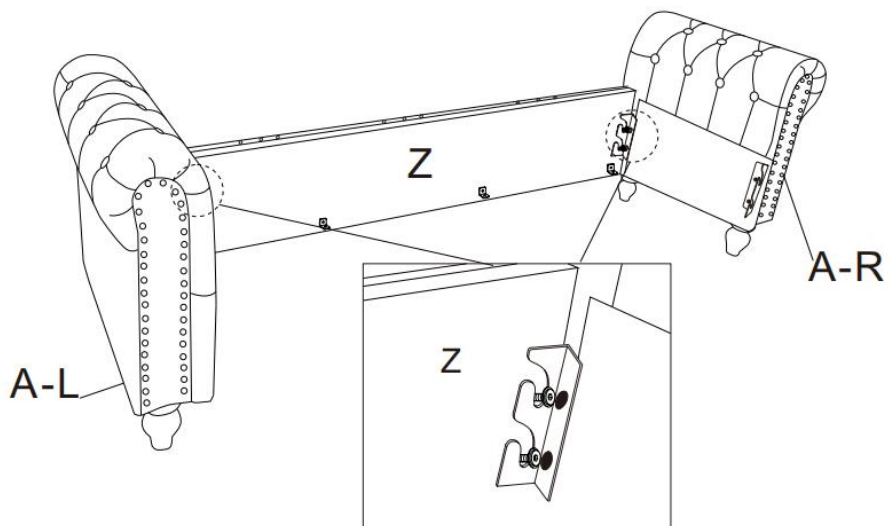

## STEP 6

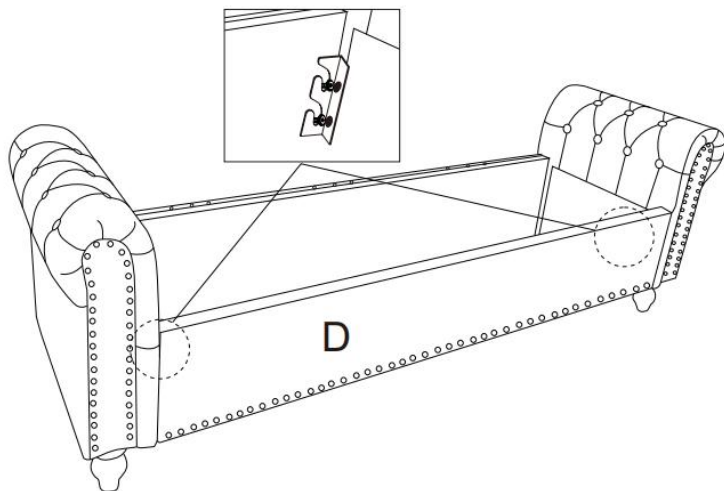

## STEP 7

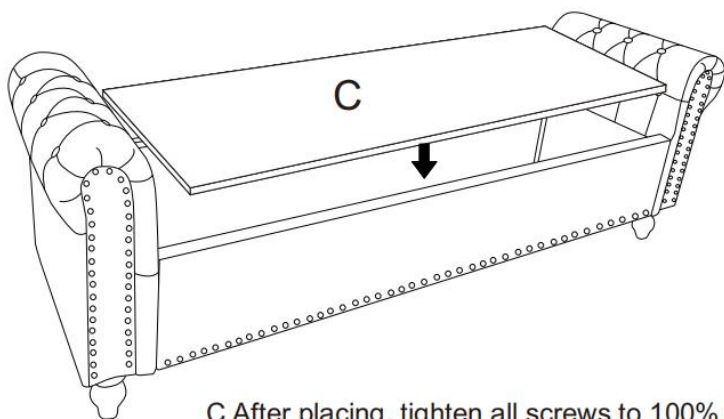

# STEP 8

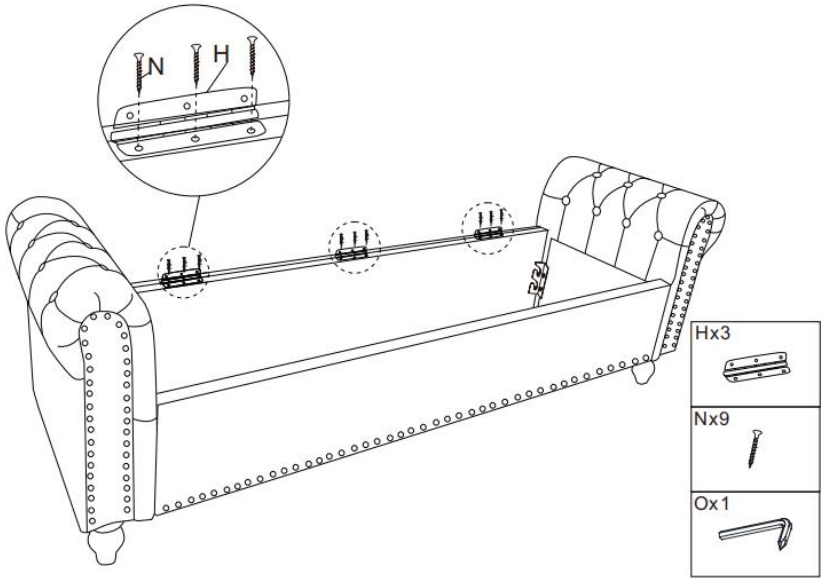

# STEP 9

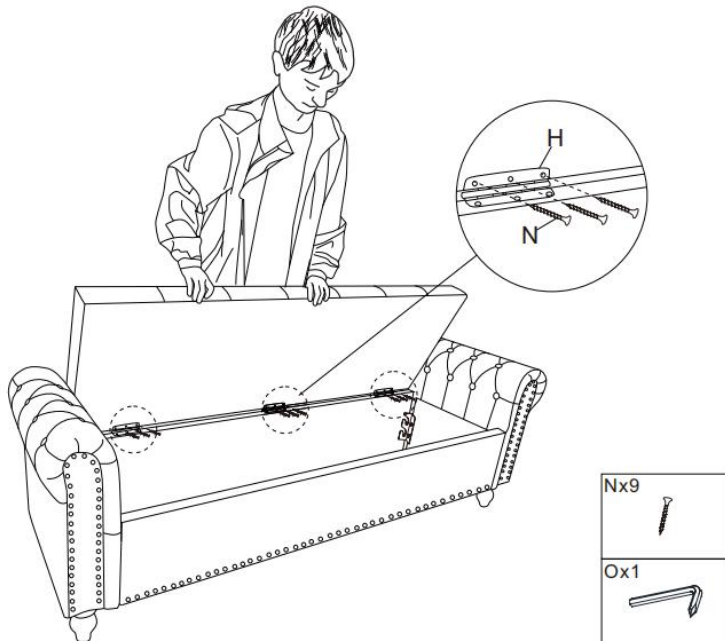

## STEP 10

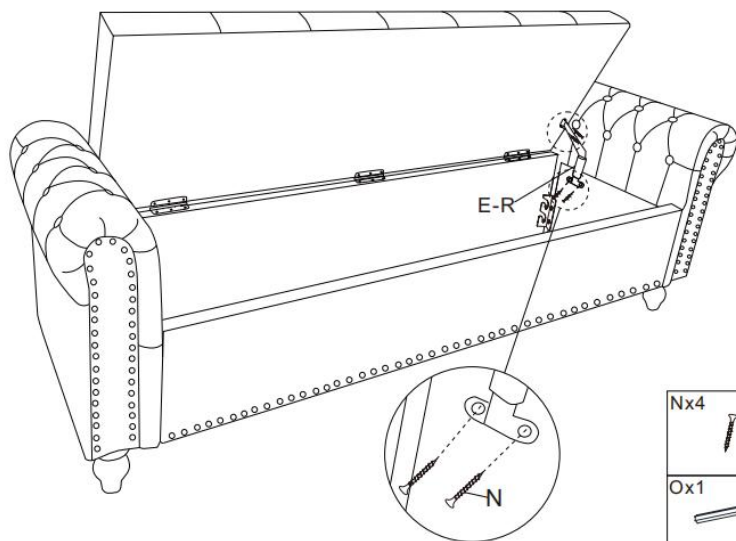

Nx4



Ox1



## STEP 11

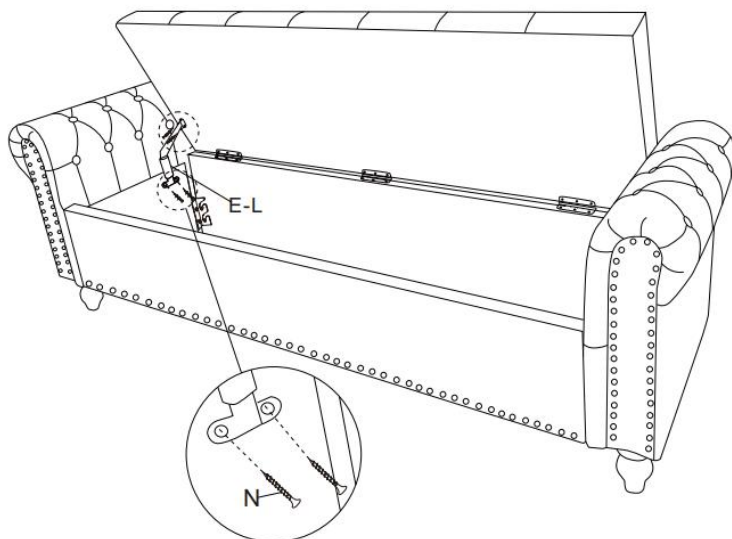

Nx4



Ox1



**STEP 12**

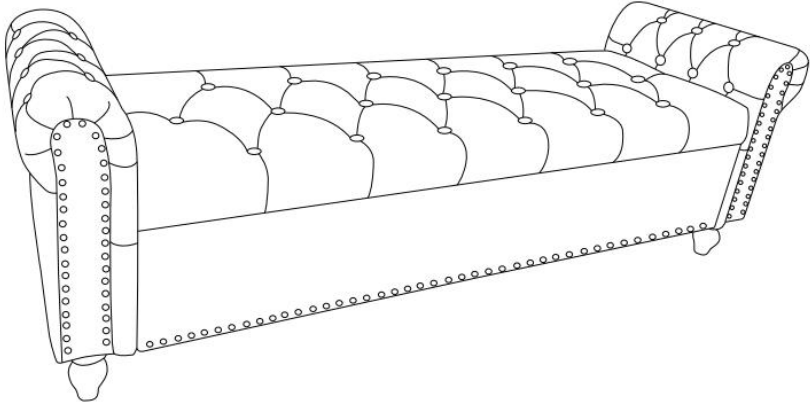

**PRODUCT PARAMETER**

<b>Model</b>	CWD0112CA- KD-BROWN	CWD0112CA- KD-BLACK	CWD0112CA- KD-GRAY
<b>Main Color</b>	Brown	Black	Gray
<b>Safe Loading Weight</b>	400 lbs		
<b>Product Size(D*W*H)</b>	460*1660*560mm		
<b>Net Weight</b>	21.8kg		

\* Products such as specifications, appearance, and design are subject to modification without prior notice.

**Manufacturer:** Shanghaimuxinmuyeyouxiangongsi

**Address:** Shuangchenglu 803nong11hao1602A-1609shi, baoshanqu, shanghai 200000 CN.

**Imported to AUS:** SIHAO PTY LTD. 1 ROKEVA STREETEASTWOOD NSW 2122 Australia

**Imported to USA:** Sanven Technology Ltd. Suite 250, 9166 Anaheim Place, Rancho Cucamonga, CA 91730



E-CrossStu GmbH  
Mainzer Landstr.69, 60329 Frankfurt am Main.



YH CONSULTING LIMITED.  
C/O YH Consulting Limited Office 147, Centurion House, London Road, Staines-upon-Thames, Surrey, TW18 4AX

