

# STANDING DESK

ES-RF2 40"-63"

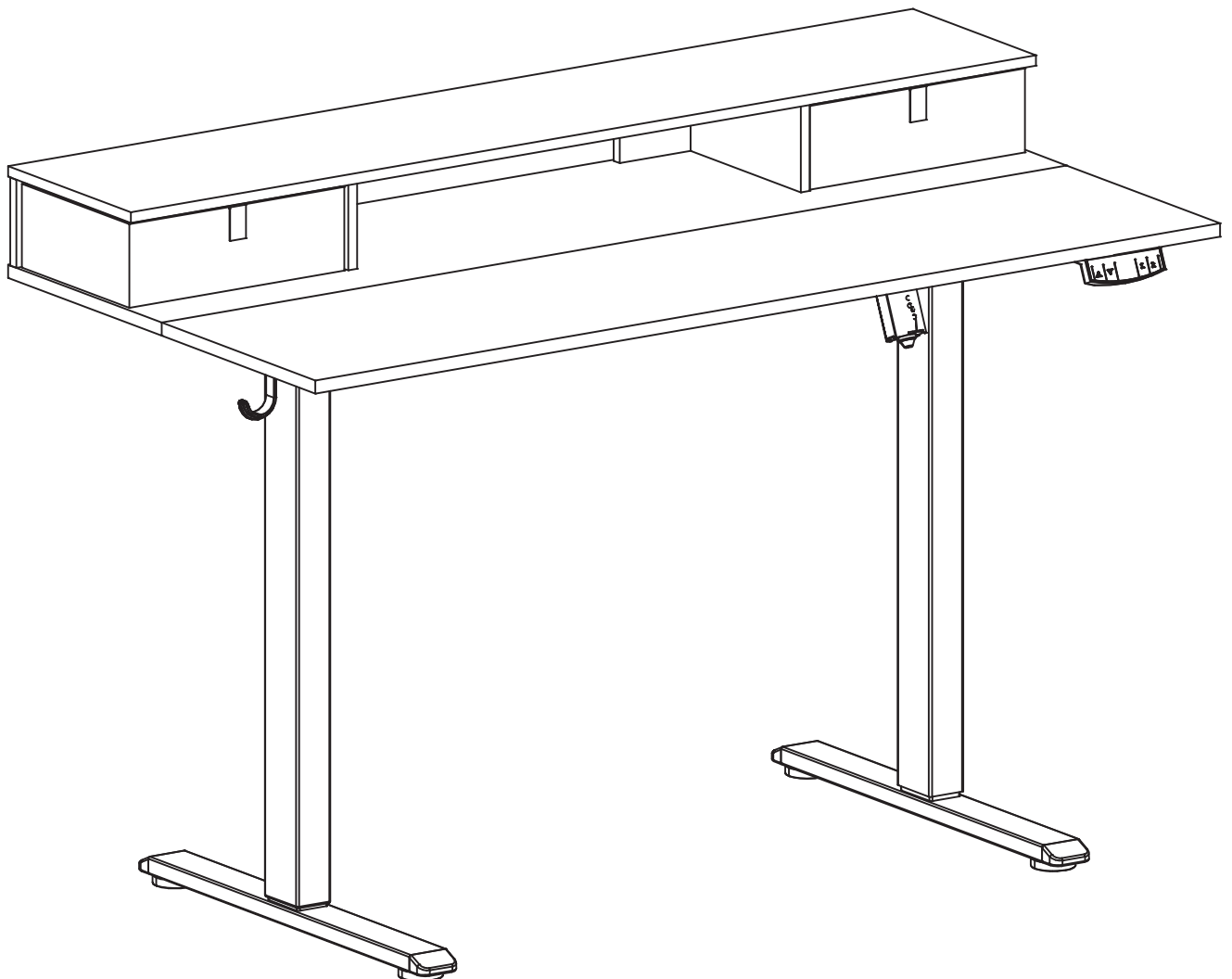

## German(DE)

### Warnung:

- Halten Sie Kinder und Tiere während des
- Gebrauchs vom Schreibtisch fern und stellen Sie sicher, dass der Schreibtisch keine Wände berührt. Bitte entfernen Sie Hindernisse 20 cm über dem Schreibtisch und 51 cm unter dem Schreibtisch während des Betriebs.
- Betreiben Sie diesen höhenverstellbaren
- Schreibtisch nur in einer Umgebungstemperatur von 0°C bis 40°C.
- r sicheren Position. Bitte lesen Sie diese Anweisungen sorgfältig durch, bevor Sie einen höhenverstellbaren Schreibtisch verwenden.
- Die Firma lehnt jegliche Garantie oder Haftung für Schäden oder persönliche Verletzungen ab, die durch abnormales oder außerhalb der Gerätebetriebsvorschriften entstehen.
- Personen ist es untersagt, sich auf den Tisch zu lehnen, um das Risiko des Umkippens zu vermeiden.
- Verwenden Sie keine scharfen Gegenstände, um die Tischplatte zu durchbohren oder zu
- zertrümmern.

## French(FR)

### Avertissement:

- Eloignez les enfants et les animaux du bureau pendant son utilisation et assurez-vous que le bureau ne touche aucun mur.
- Veuillez retirer les obstacles situés à 20 cm au-dessus du bureau et à 51 cm en dessous du bureau pendant le fonctionnement.
- Utilisez ce bureau réglable uniquement dans une température ambiante de 0°C à 40°C.
- Éloignez les produits des gaz corrosifs, des liquides et des objets poussiéreux.
- Gardez vos mains, vos pieds et autres parties du corps dans une position sûre pendant le fonctionnement.
- Veuillez lire attentivement ces instructions avant
- d'utiliser un bureau à hauteur réglable.
- La société décline toute garantie ou responsabilité pour tout dommage ou blessure personnelle résultant d'un fonctionnement anormal ou en dehors des réglementations d'utilisation de l'équipement.
- Il est interdit aux personnes de s'appuyer sur la table pour éviter les risques de basculement. N'utilisez pas d'objets tranchants pour percer ou
- briser les bureaux.

## Spanish(ES)

### Advertencia:

- Mantenga a los niños y a los animales alejados del escritorio durante su uso y asegúrese de que el escritorio no toque ninguna pared.
- Por favor, retire los obstáculos a 20 cm por encima del escritorio y a 51 cm por debajo del escritorio durante el funcionamiento.
- Utilice este escritorio ajustable solo en un entorno operativo con una temperatura de 0°C a 40°C. Mantenga los productos alejados de gases corrosivos, líquidos y objetos polvorientos. Mantenga las manos, los pies y otras partes del cuerpo en una posición segura durante el funcionamiento.
- Por favor, lea cuidadosamente estas instrucciones antes de utilizar un escritorio de altura ajustable. La empresa declina cualquier garantía o responsabilidad por cualquier dano o lesión
- personal resultante de un funcionamiento anormal o de regulaciones de funcionamiento fuera de equipo.
- Se prohíbe que las personas se apoyen en la mesa para evitar riesgos de vuelco. No utilice objetos afilados para perforar o romper
- los escritorios..

## Italian(IT)

### Avvertimento:

- Tenere i bambini e gli animali lontani dalla
- scrivania durante l'uso e assicurarsi che la scrivania non tocchi nessun muro.
- Si prega di rimuovere gli ostacoli a 20 cm sopra la scrivania e a 51 cm sotto la scrivania durante il funzionamento.
- Utilizzare questa scrivania regolabile solo in un ambiente operativo con temperatura compresa tra 0°C e 40°C.
- Tenere i prodotti lontani da gas corrosivi, liquidi e oggetti polverosi. Tenere le mani, i piedi e altre parti del corpo in una posizione sicura durante il funzionamento.
- Si prega di leggere attentamente queste istruzioni prima di utilizzare una scrivania regolabile in altezza. La società declina qualsiasi garanzia o responsabilità per eventuali danni o lesioni
- personali derivanti da un funzionamento anormale o da regolamenti di utilizzo dell'attrezzatura al di fuori della norma.
- È vietato alle persone appoggiarsi sul tavolo per evitare rischi di ribaltamento.
- Non utilizzare oggetti appuntiti per forare o
- sfondare le scrivanie.

English(EN)

Alert:

- Keep children and animals away from the desktop during use and ensure that the desktop does not touch any walls.
- Please remove obstacles 20CM above the desktop and 51CM below the desktop during operation.
- Only operate this adjustable desk in the temperature of 32°F-104°F/0°C-40°C operating environment.
- Keep products away from corrosive gases, liquids, and dusty objects.
- Keep your hands, feet, and other body parts in a safe position while operating.
- Please read these instructions carefully before using an adjustable-height desk.
- The Company disclaims any warranty or liability for any damage or personal injury resulting from abnormal or outside-of-equipment operation regulations.
- People are prohibited from leaning on the table to avoid tipping risks.
- Do not use sharp objects to poke/smash desktops.

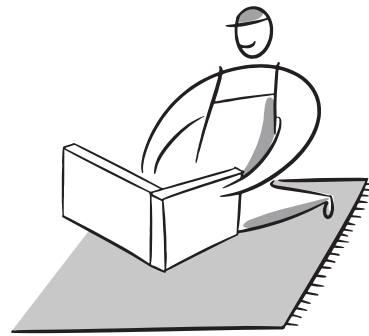
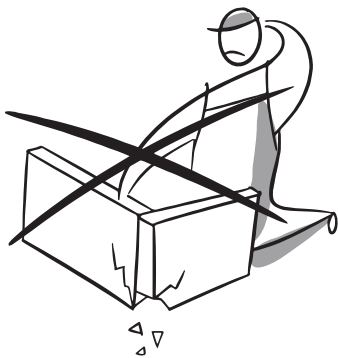

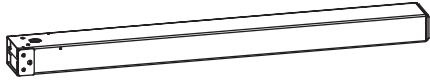

**1** X1



**2** X1



**3** X1

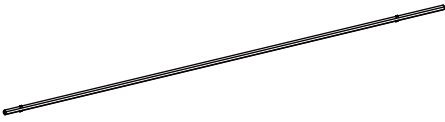

**4** X1

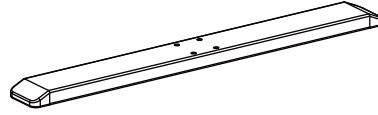

**5** X2

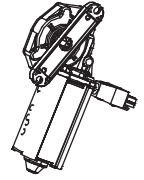

**6** X1



**7** X2



**8** X1

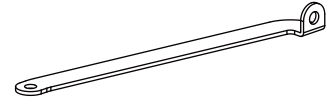

**9** X1

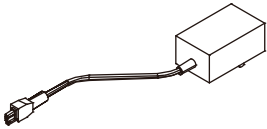

**10** X1

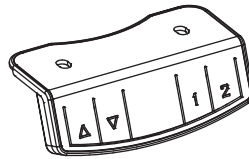

**11** X1

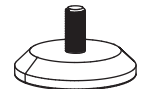

**12** X4

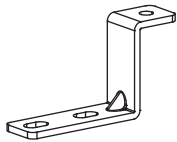

**13** X1 (40"/48" 1m/1.2m )  
X2 (55"/63" 1.4m/1.6m )



(40"/48" 1m/1.2m)

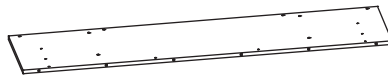

(55"/63" 1.4m/1.6m)

**14** X1

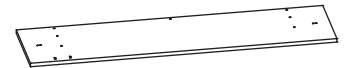

(40"/48" 1m/1.2m)



(55"/63" 1.4m/1.6m)

**15** X1

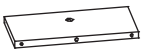

**16** X2

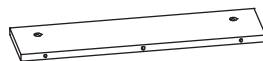

**17** X2



**18** X1

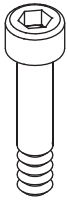

M6X32

**A** X8

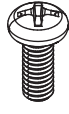

M4X10

**B** X2

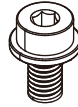

M6X8

**C** X4

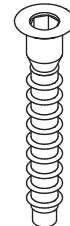

M6.3X50

**D** X8



M6X8

**E** X9 (40"/48")  
1m/1.2m

X10 (55"/63")  
1.4m/1.6m



ST4.8X13

**F** X20 (40"/48")  
1m/1.2m

X22 (55"/63")  
1.4m/1.6m



ST6X40

**G** X6



φ 12

**H** X6



φ8X40

**J** X4 (40"/48")  
1m/1.2m

X6 (55"/63")  
1.4m/1.6m



φ6X40

**K** X10



**L** X1

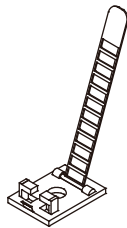

**M** X3

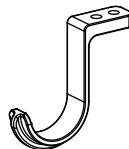

**N** X2

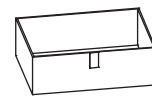

**P** X2

# 1

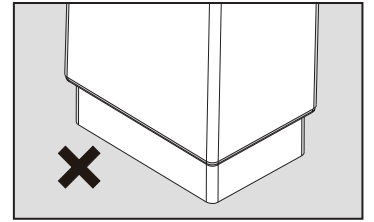
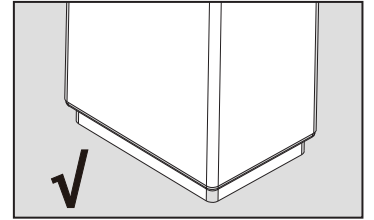
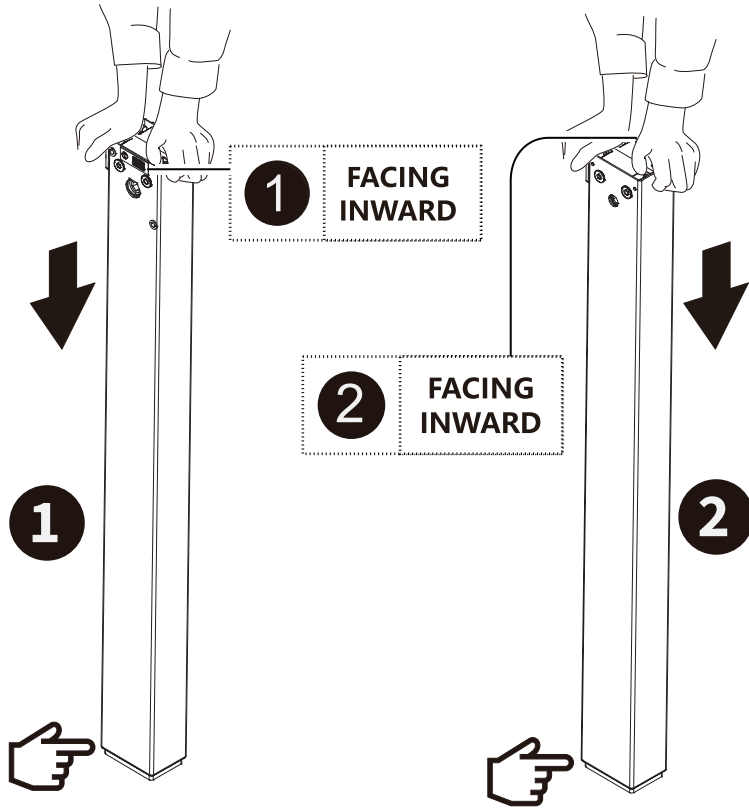

**Attention:** Check if the height of the two desk legs is consistent. If there is a significant difference, press down to ensure the heights of the two legs are the same.

# 2

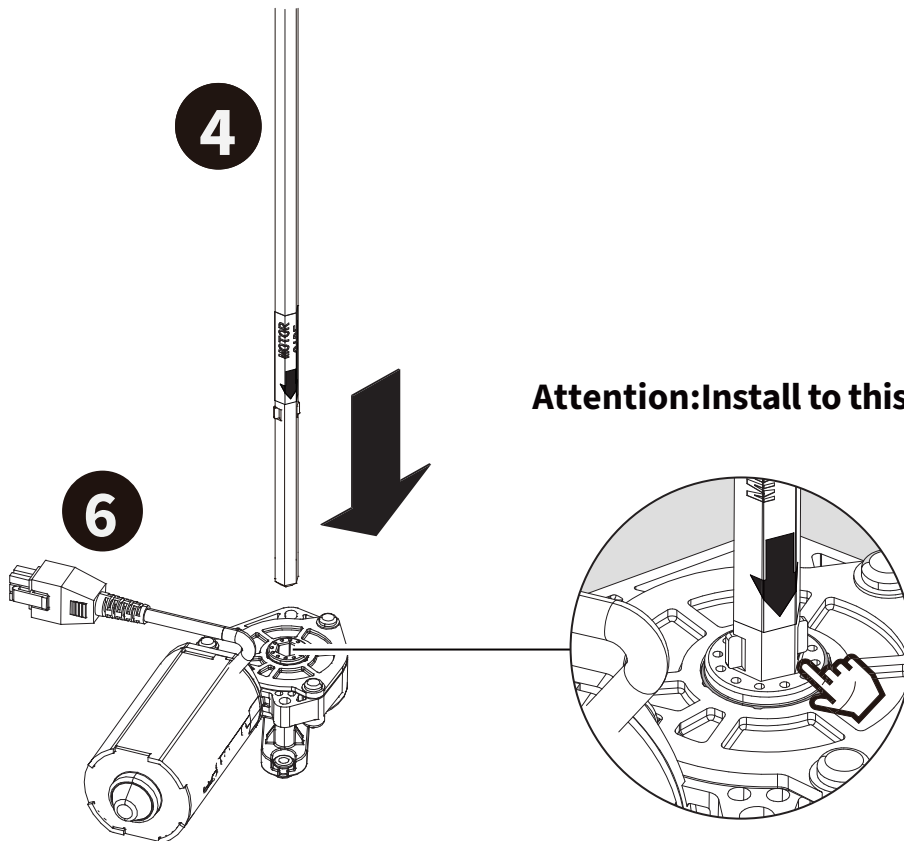

**Attention:** Install to this position.

# 3

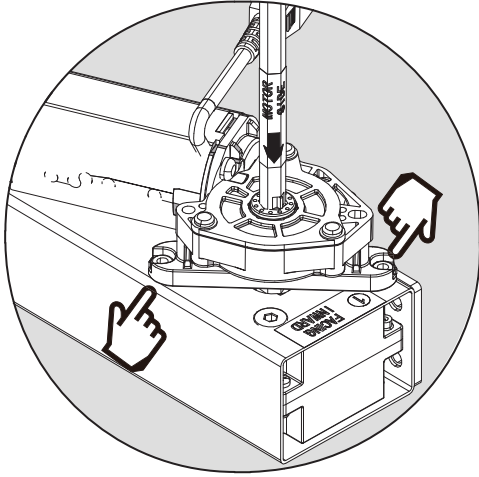

**!** Attention: The motor mounting hole is located on this side.

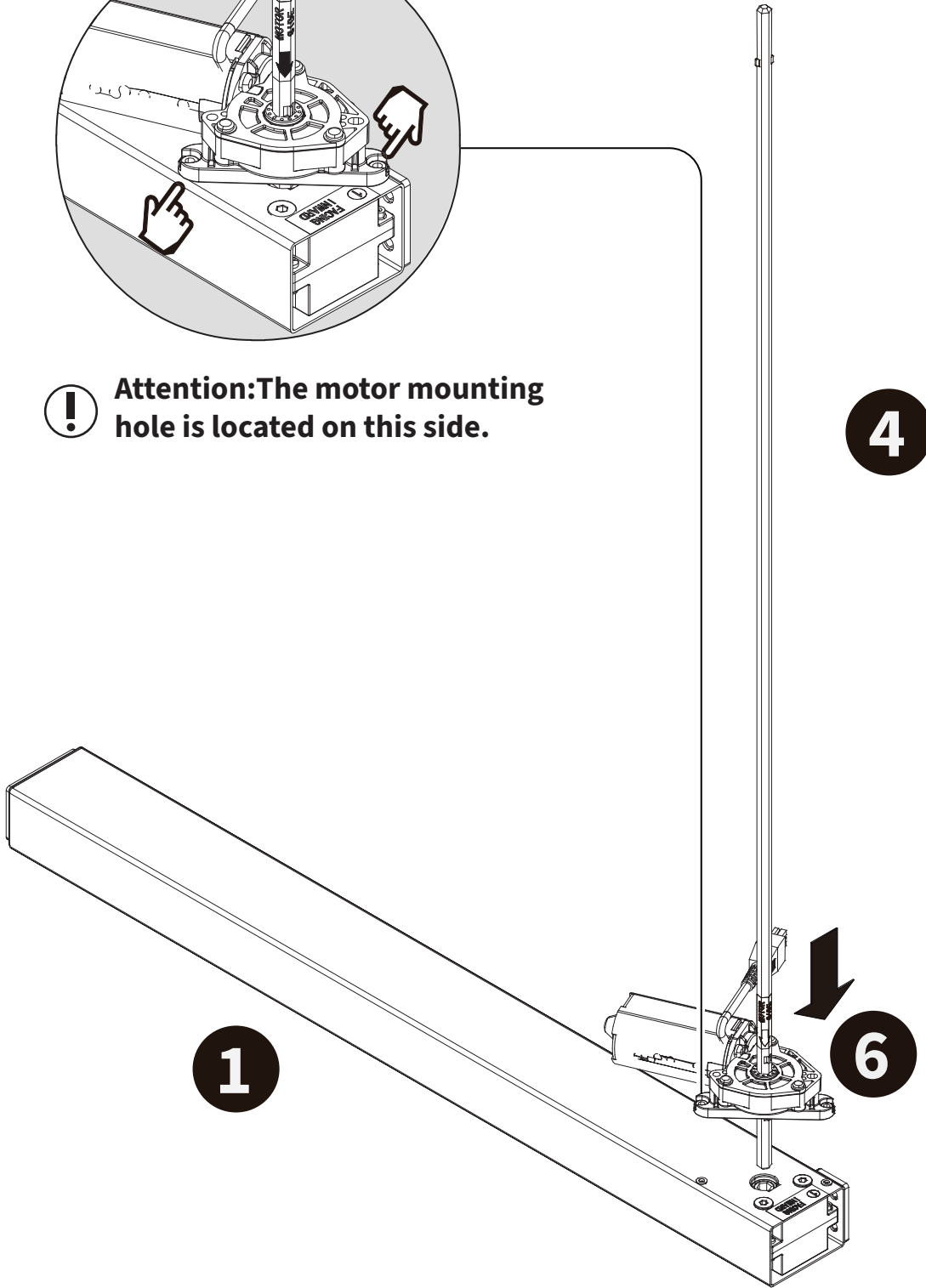

# 4

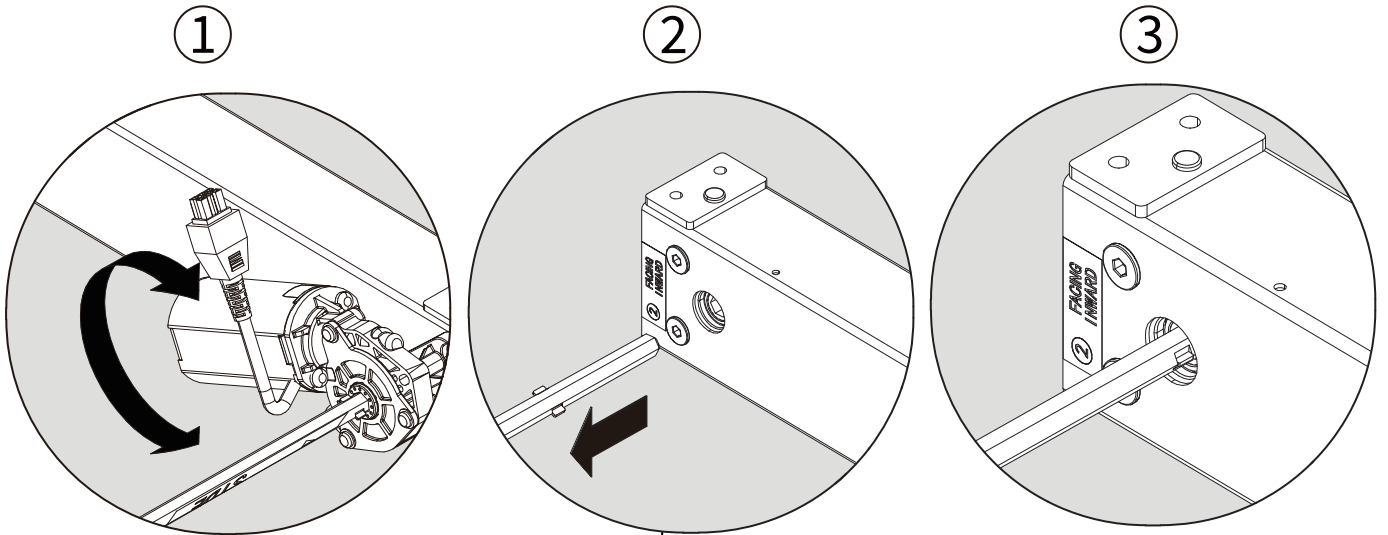

Rotating the motor to make sure the hexagonal metal rod fits into the hole of the table leg labeled 1.

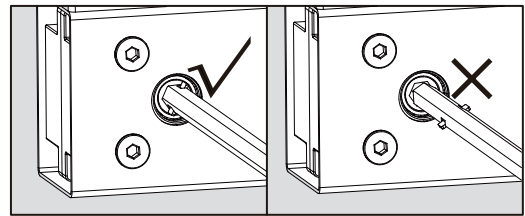

**Attention:** The column pads face up, and the leg pads labeled 1 face the same direction.

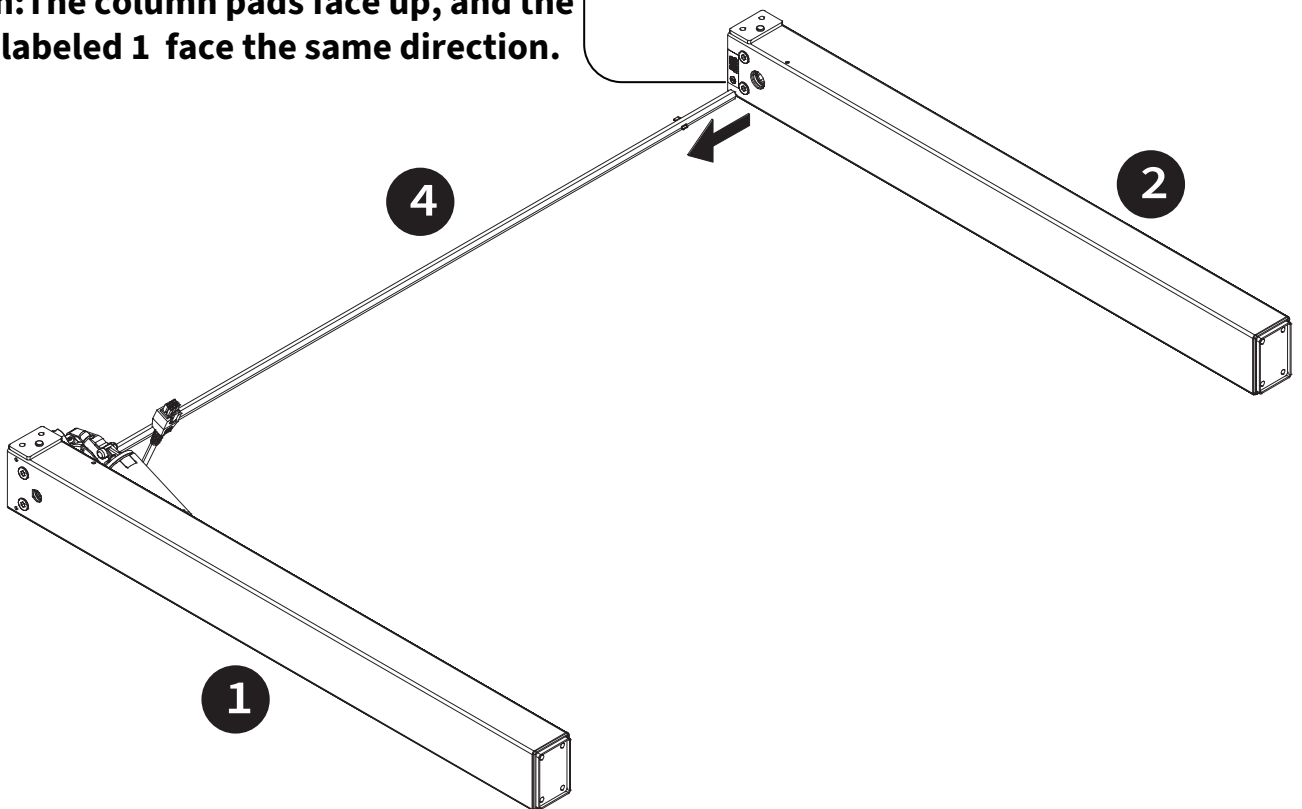

# 5

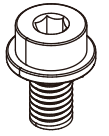
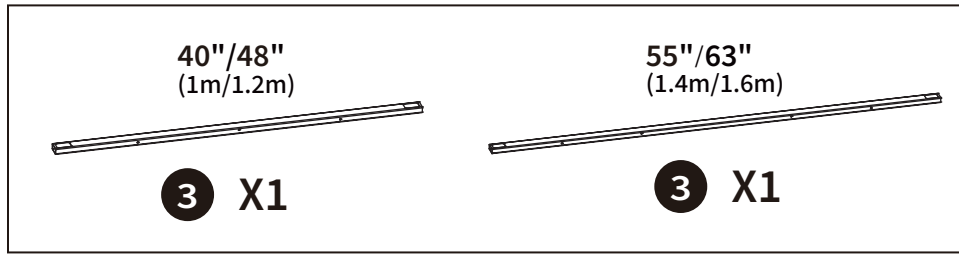

M6X8

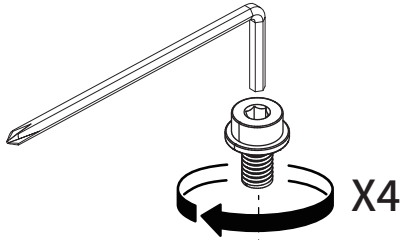

X4



**Prefasten all screws and then tighten all screws.**

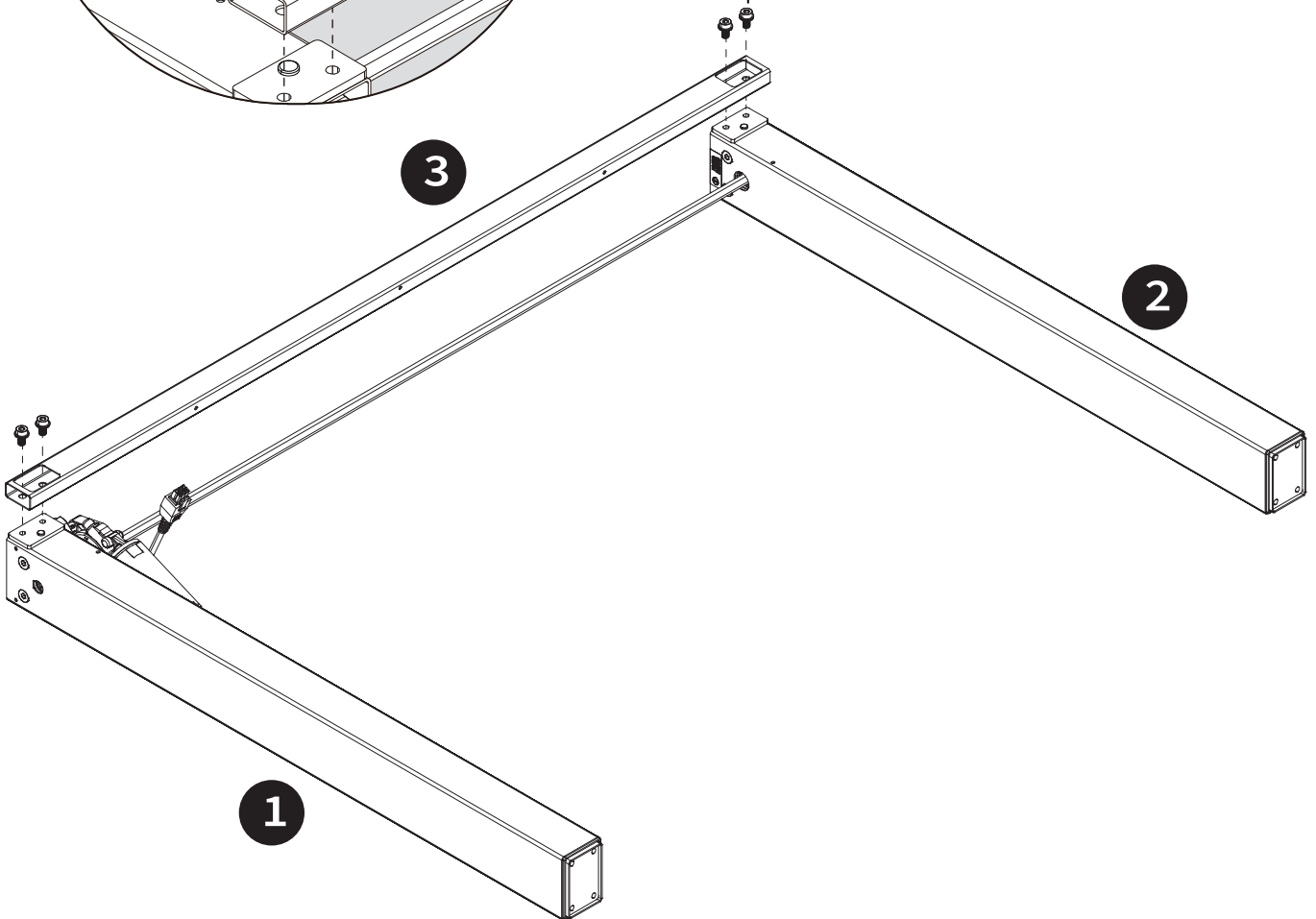

# 6

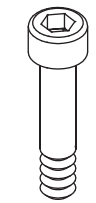
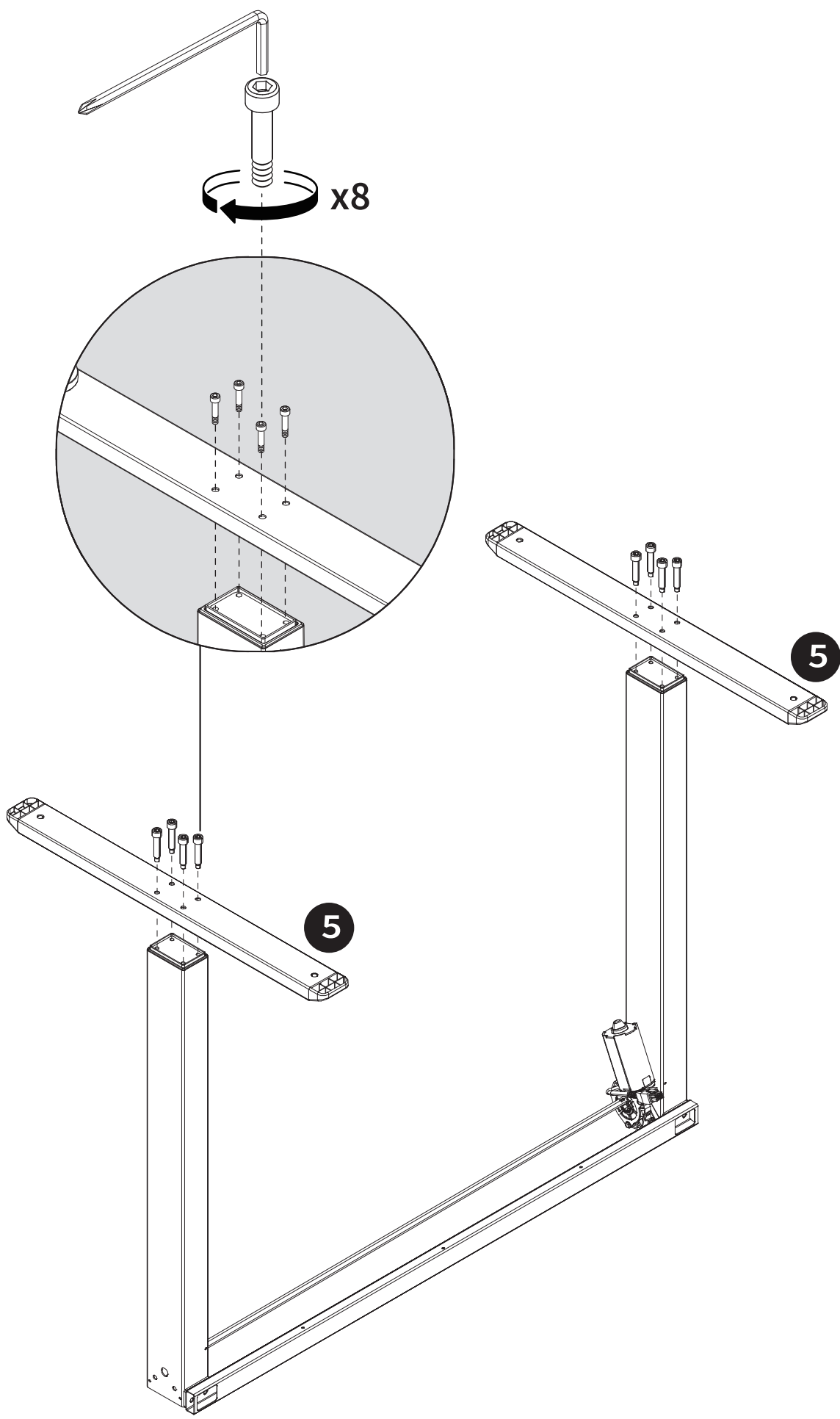

M6X32



7

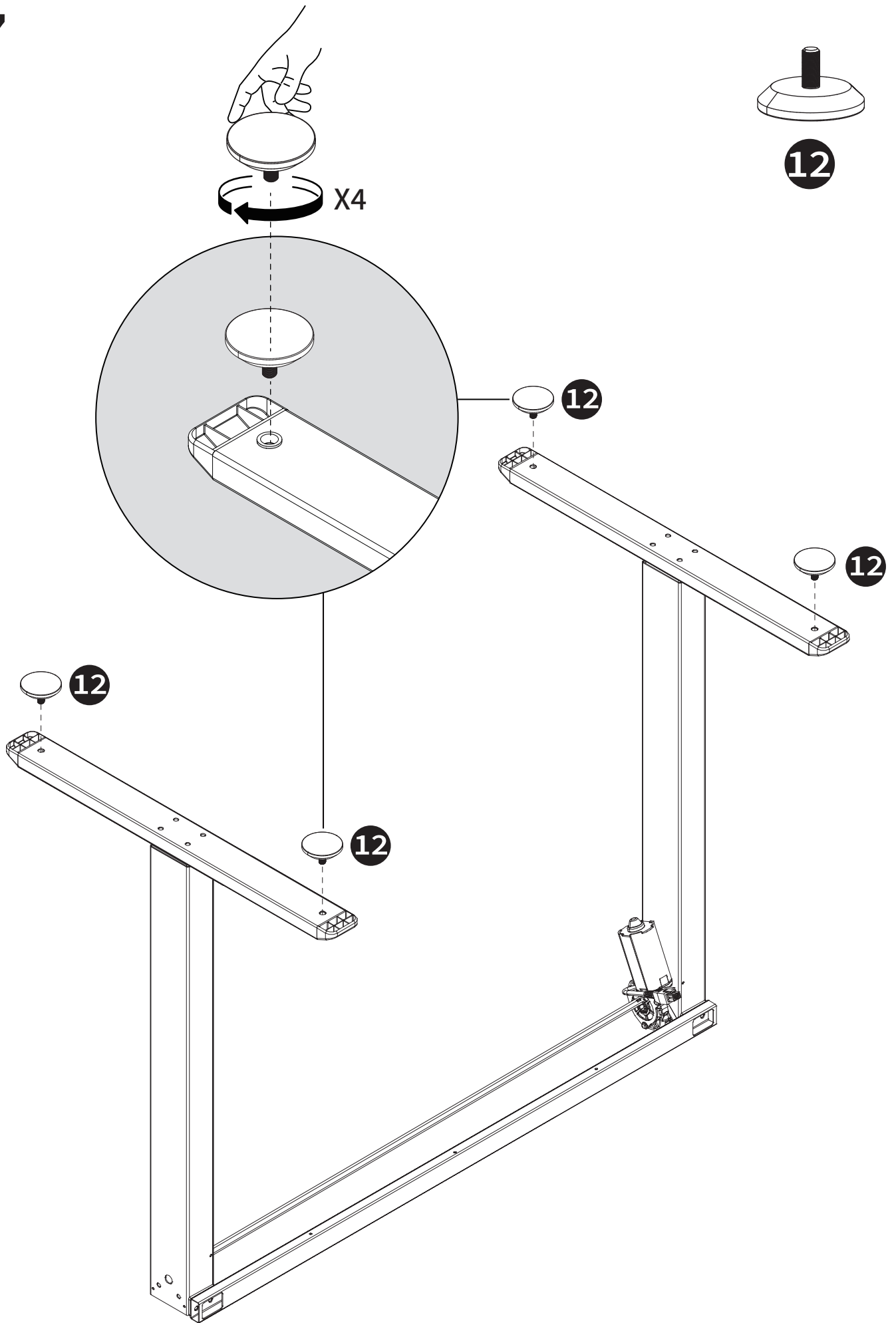

8

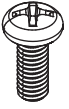

M4X10

**B**

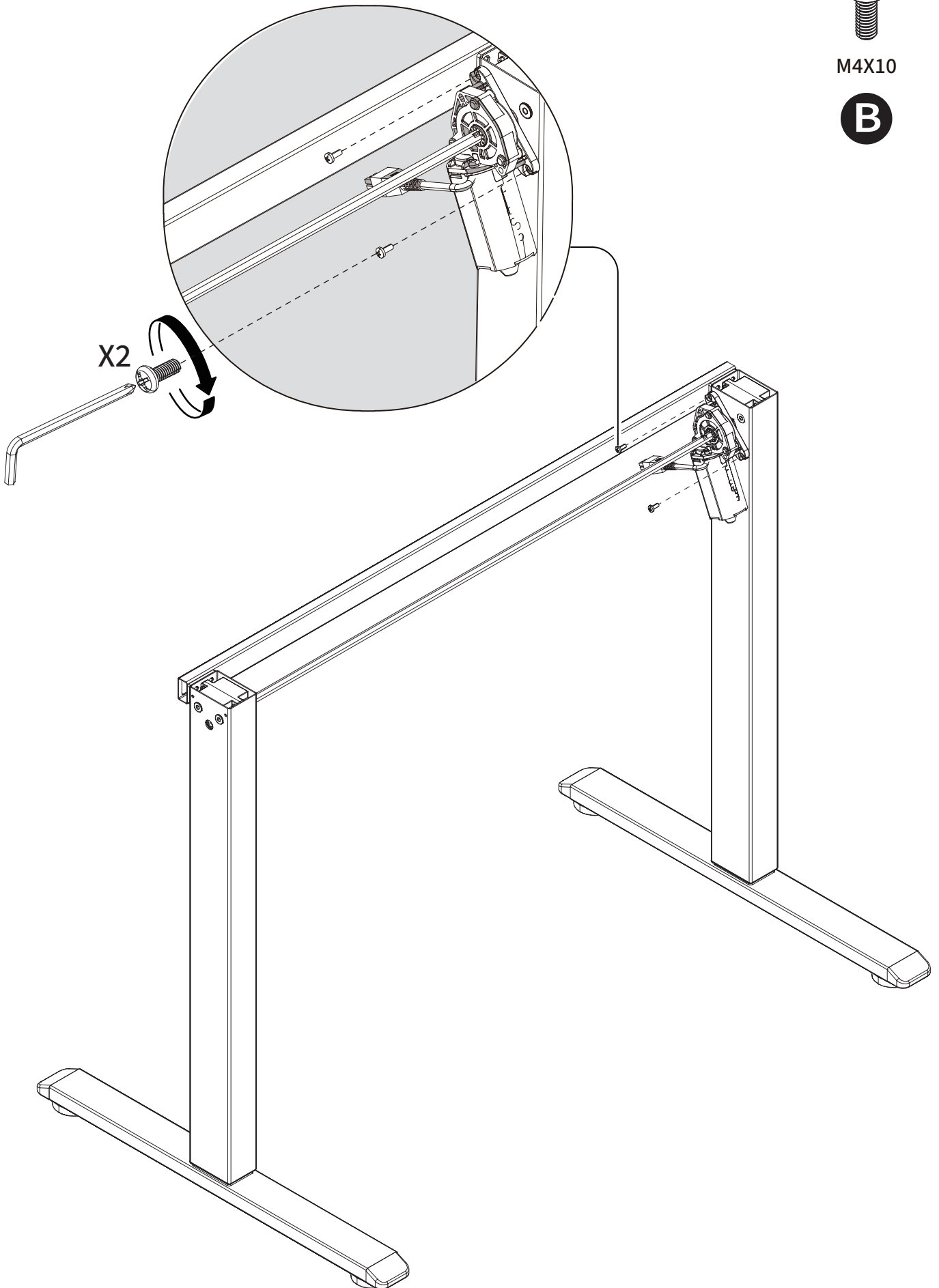

# 9

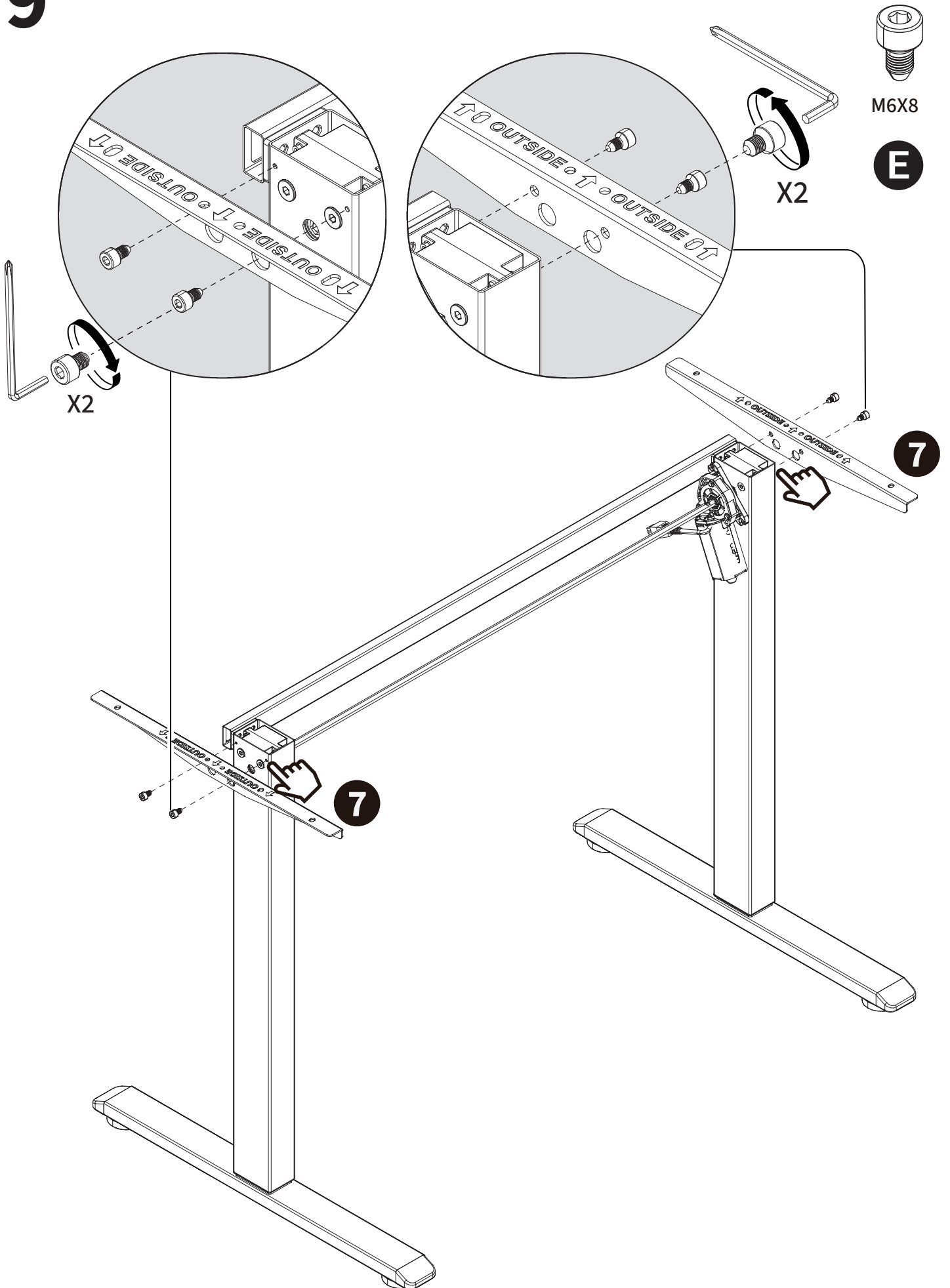

# 10

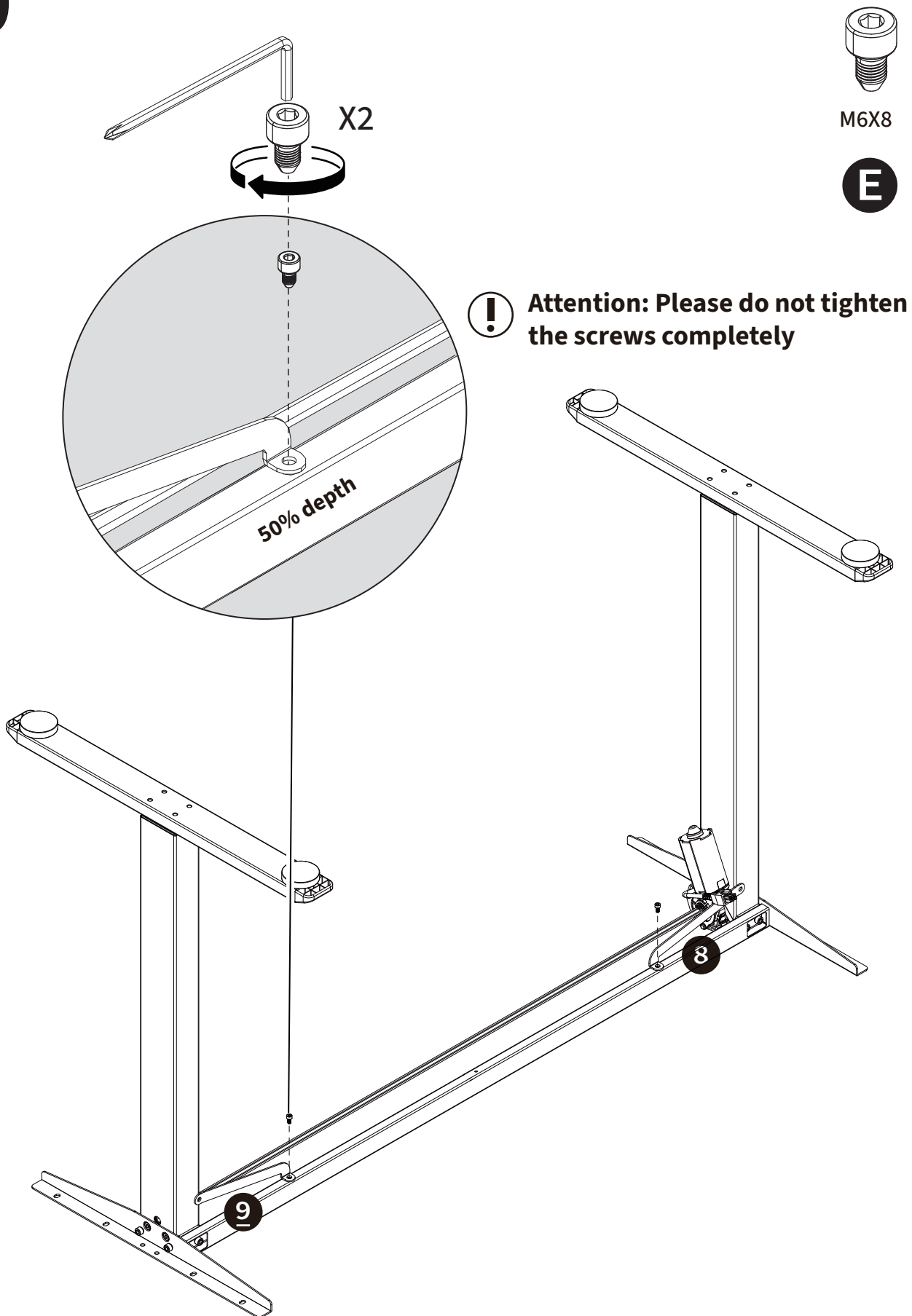

# 11

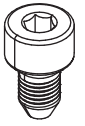

M6X8

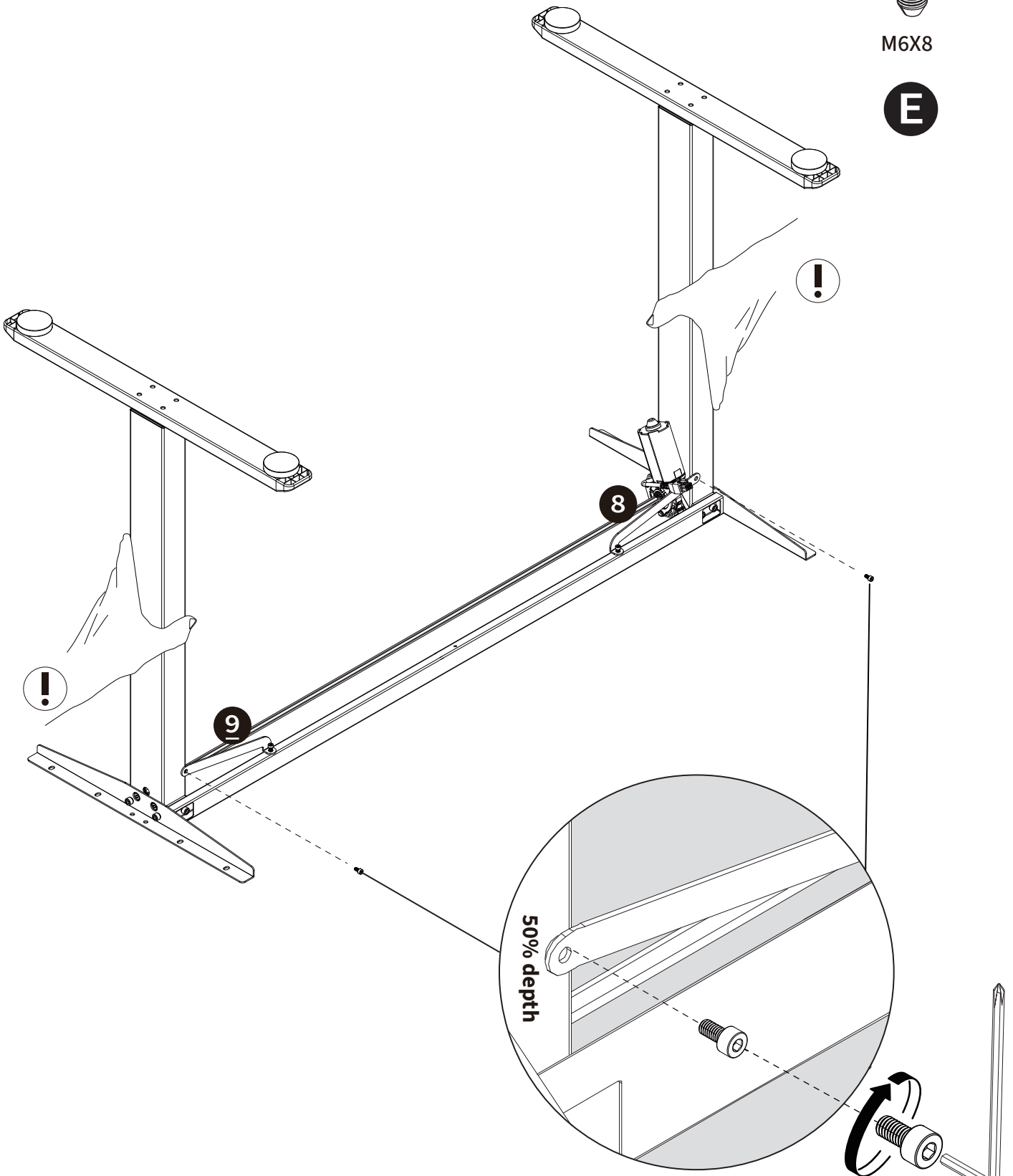

 **Attention: Please do not tighten the screws completely**

# 12

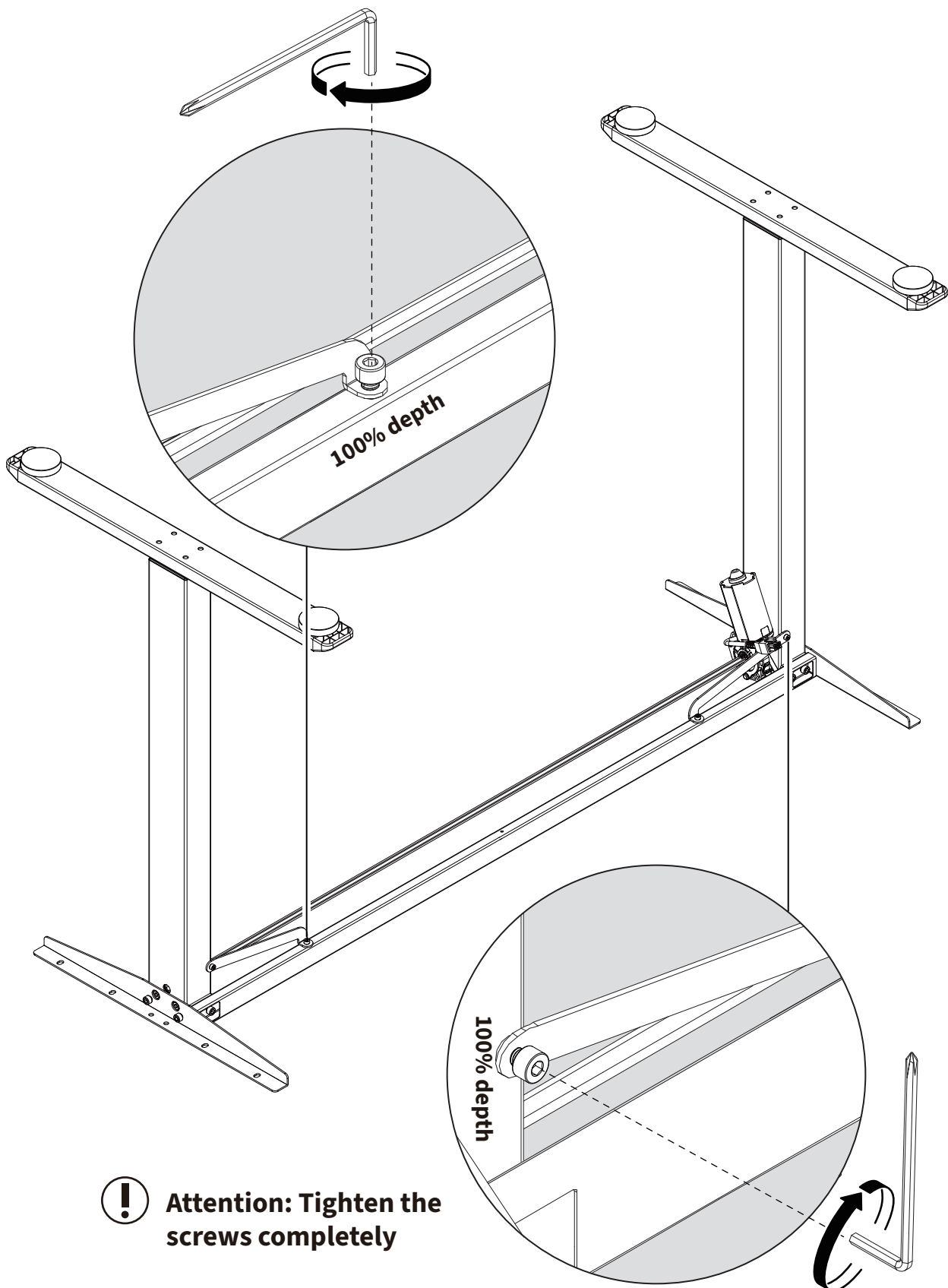

**!** Attention: Tighten the screws completely

# 13

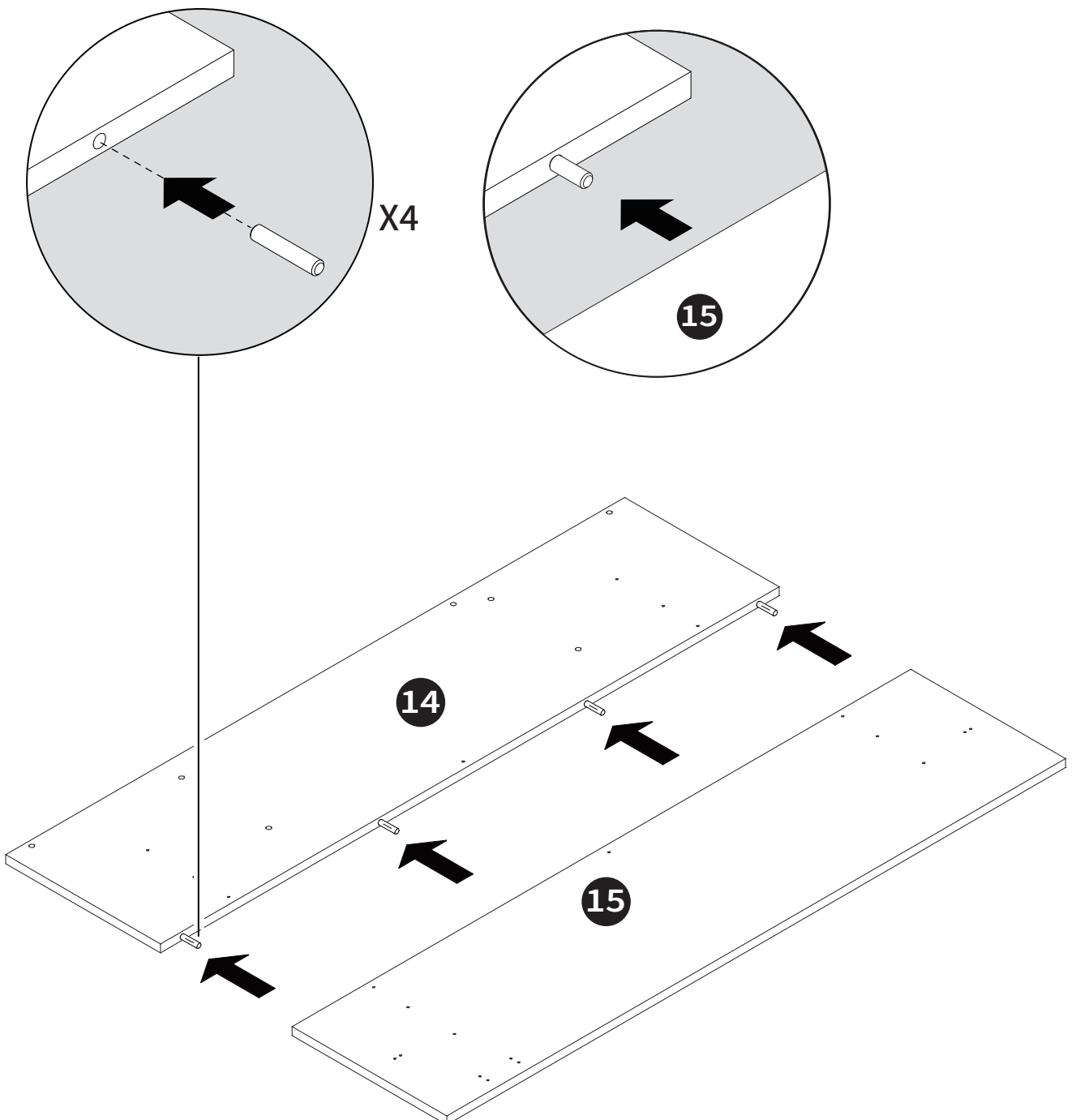
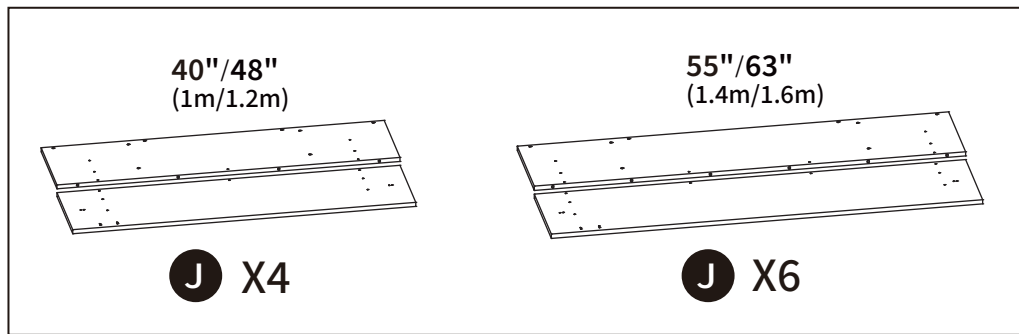

# 14



ST4.8X13

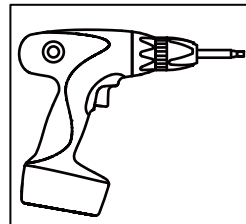
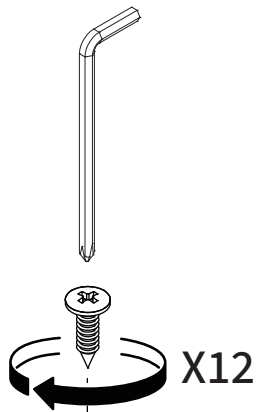

**Attention:**The recommended torque gear of the electric screwdriver is between 8 and 12.

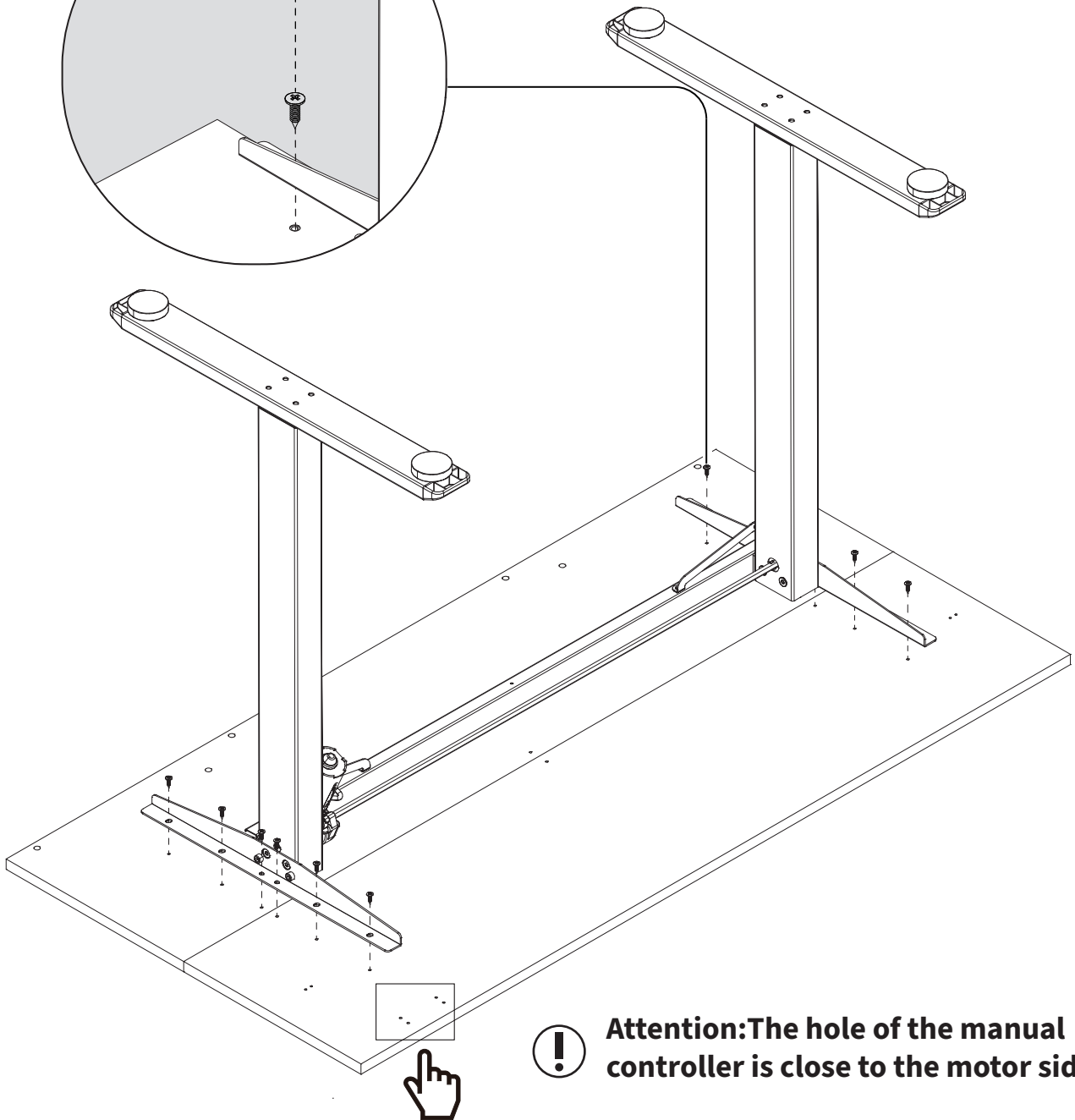
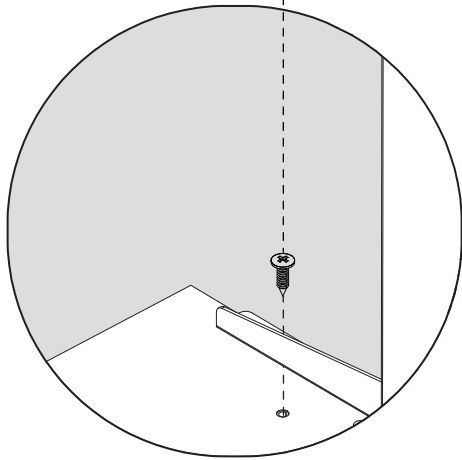

**Attention:**The hole of the manual controller is close to the motor side.

# 15

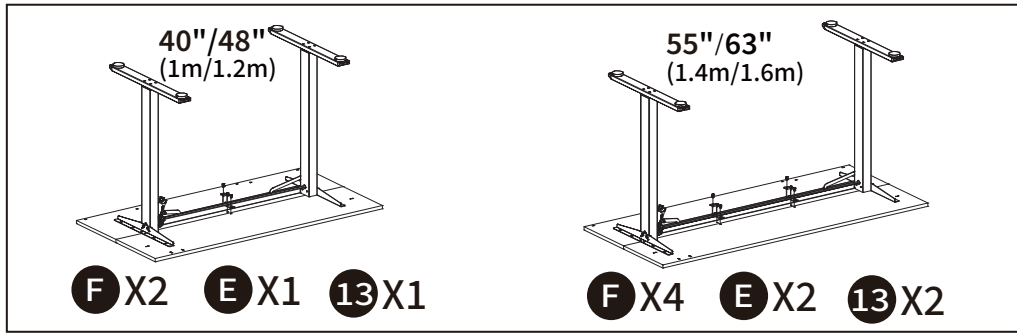

ST4.8X13

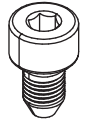

M6X8

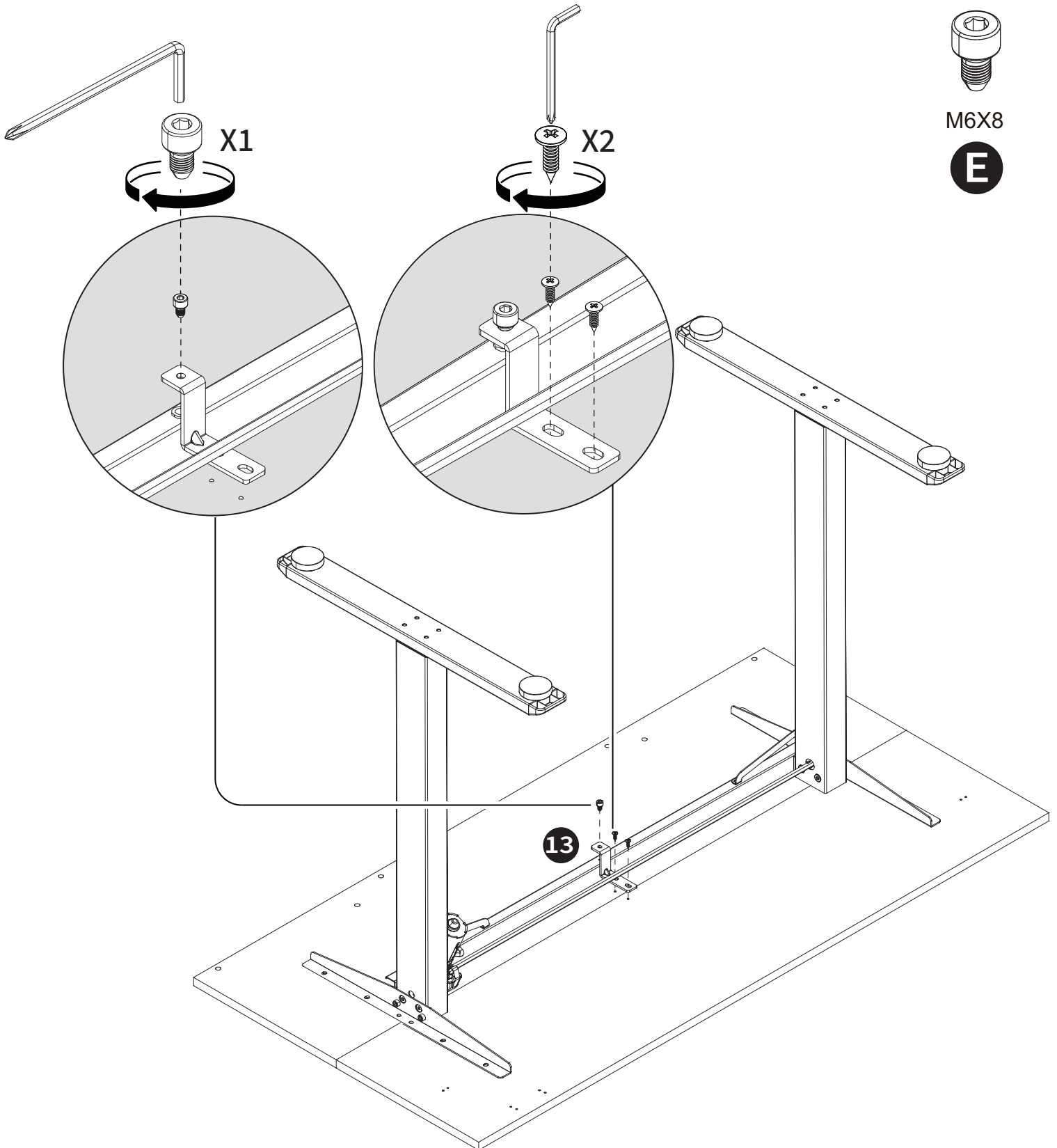

# 16



ST4.8X13

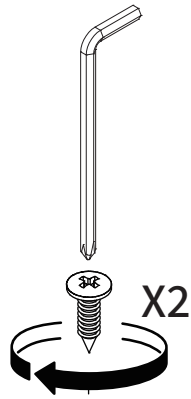

X2

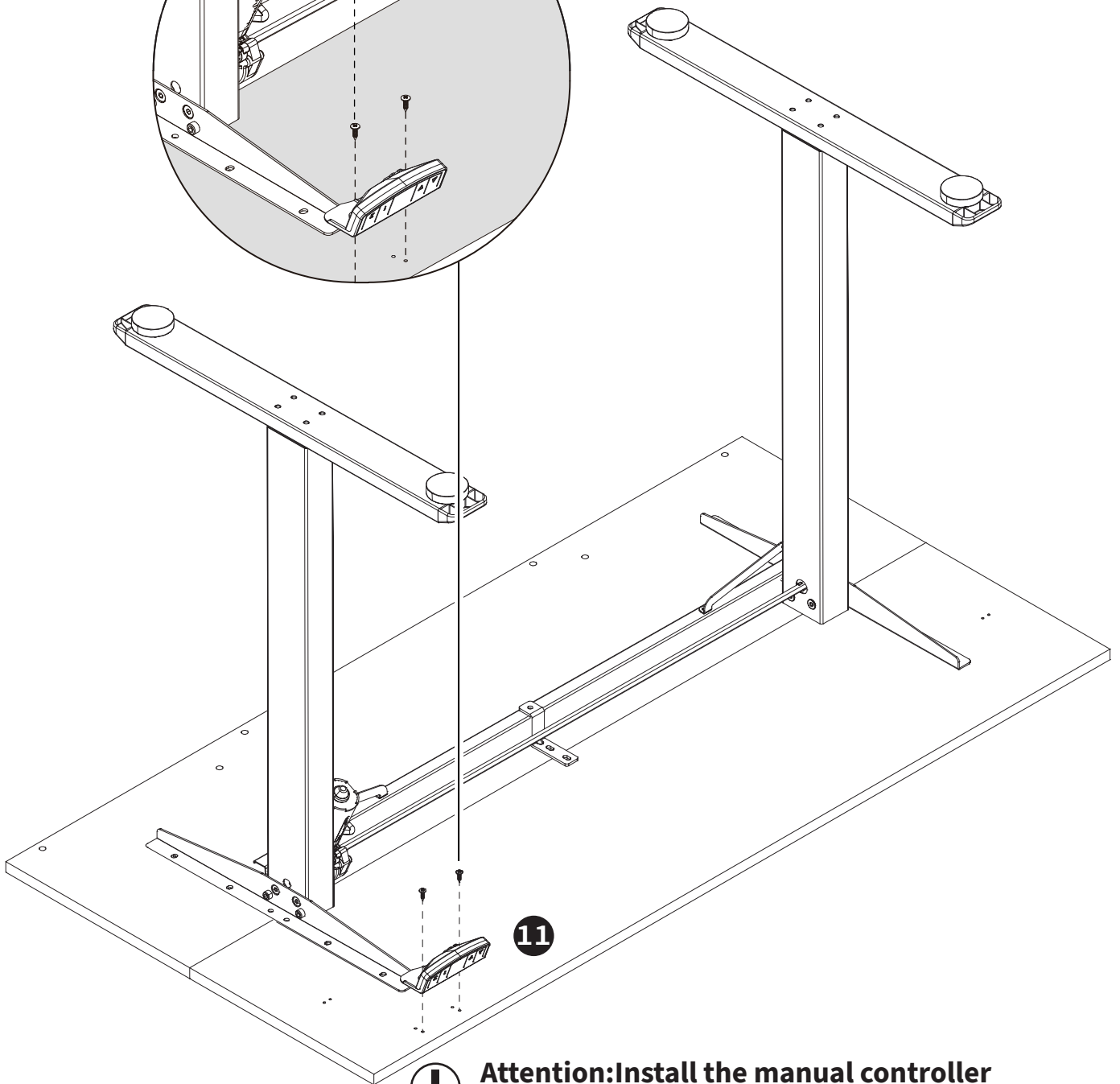
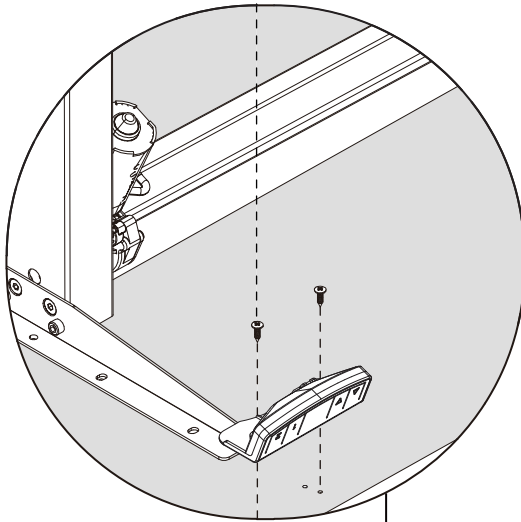

**Attention: Install the manual controller by the hole on the outside of the desktop.**

# 17

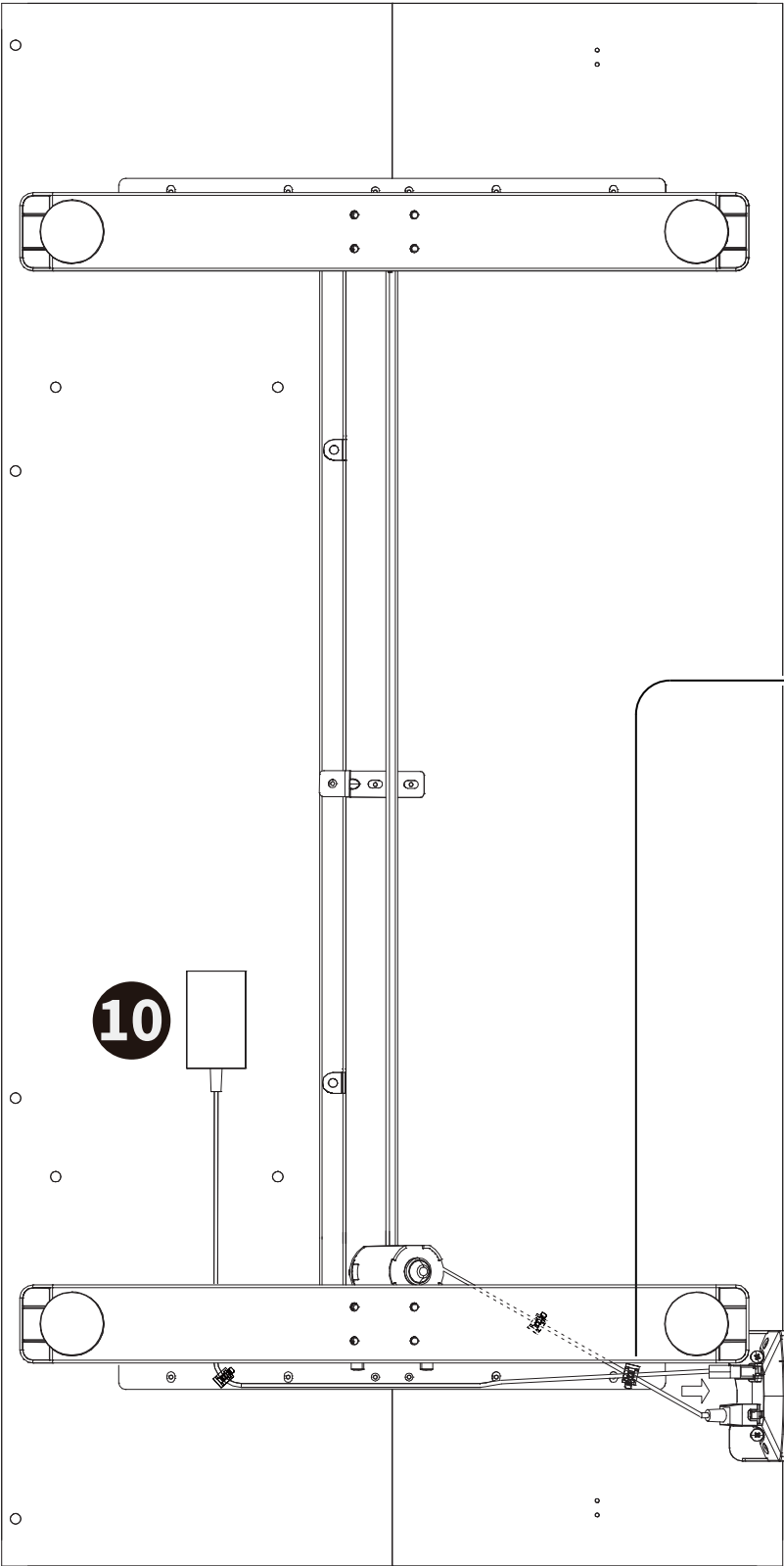

**M**

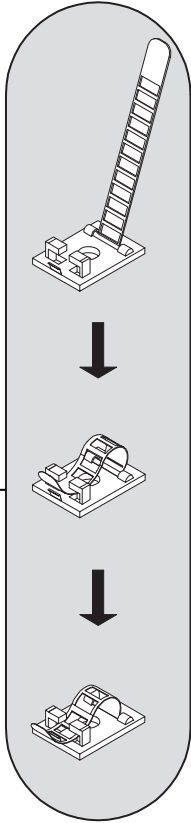

**X3**

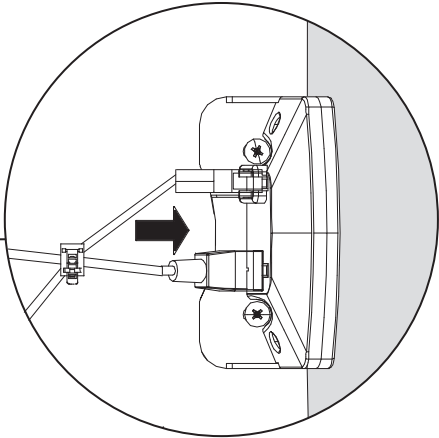

# 18

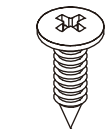
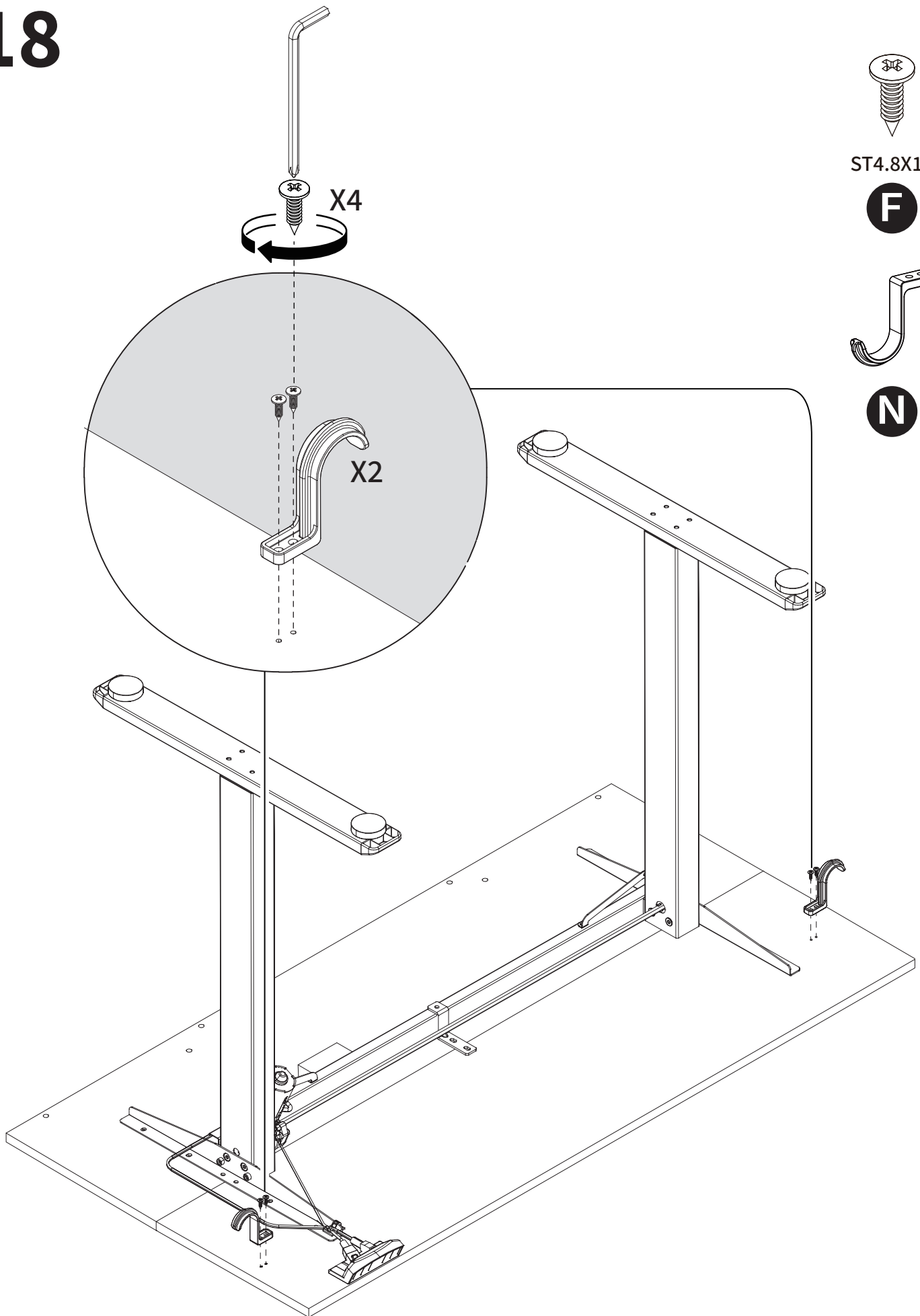

ST4.8X13

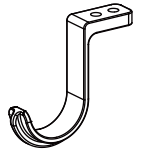

# 19

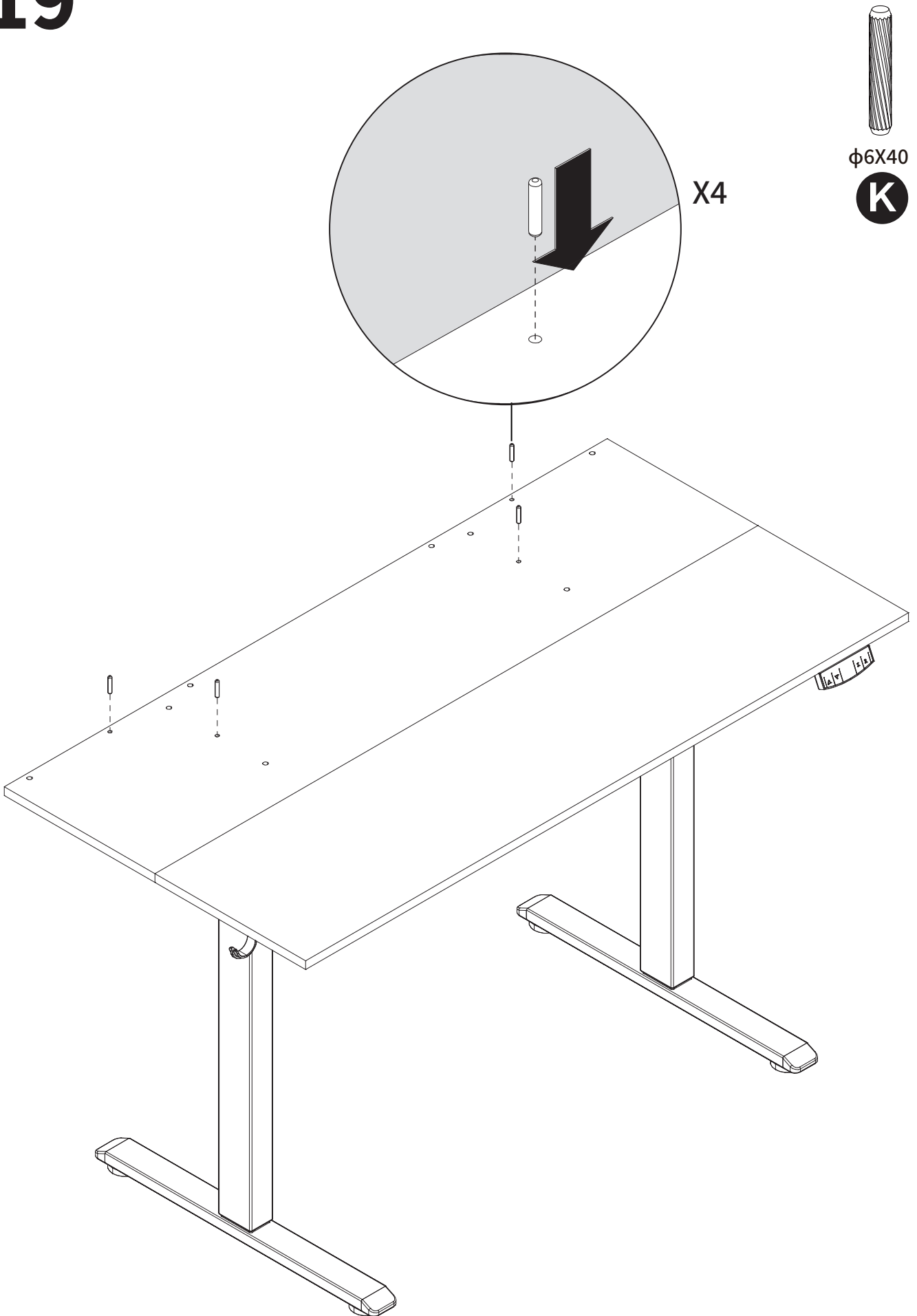

# 20

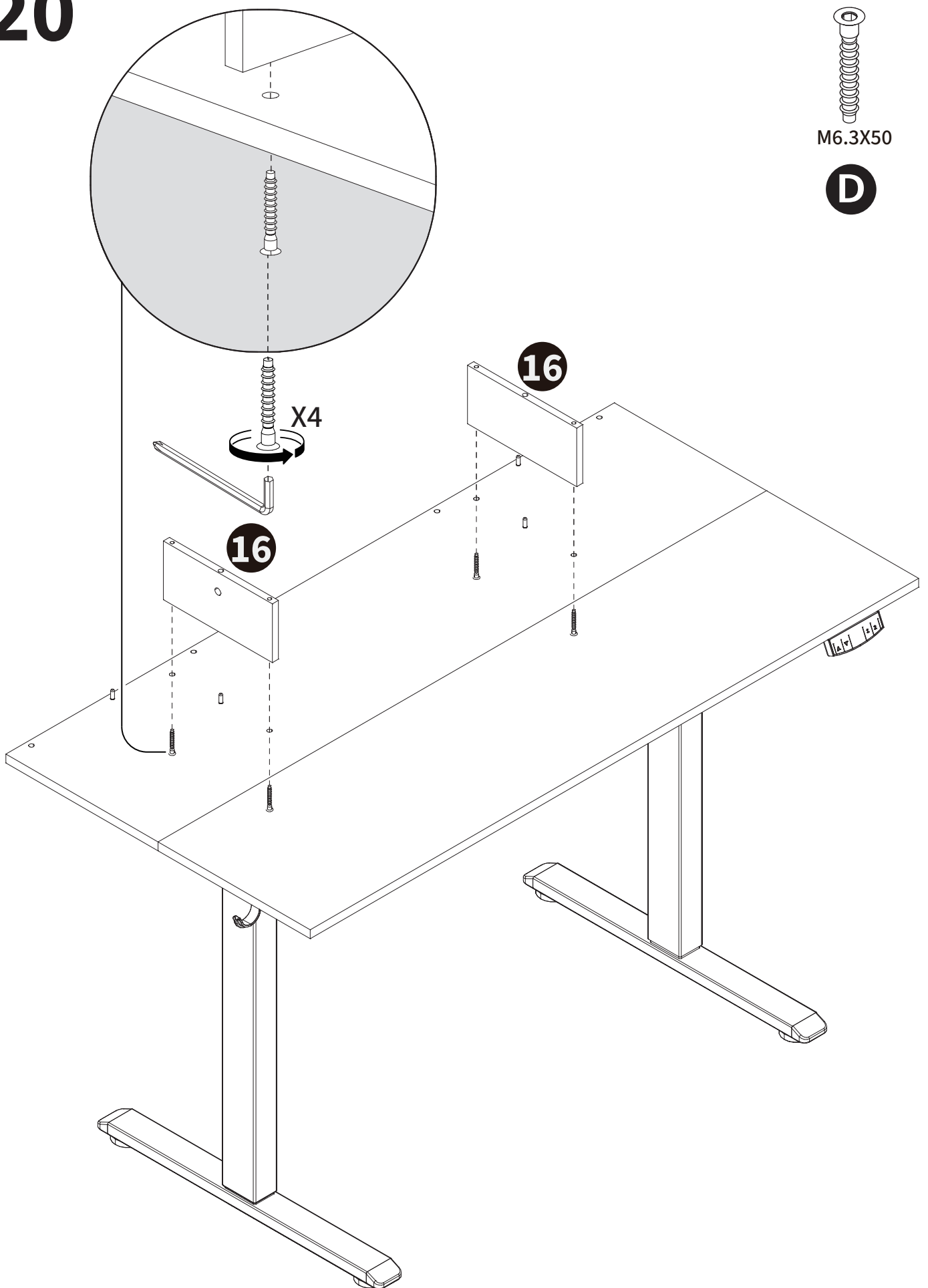

# 21

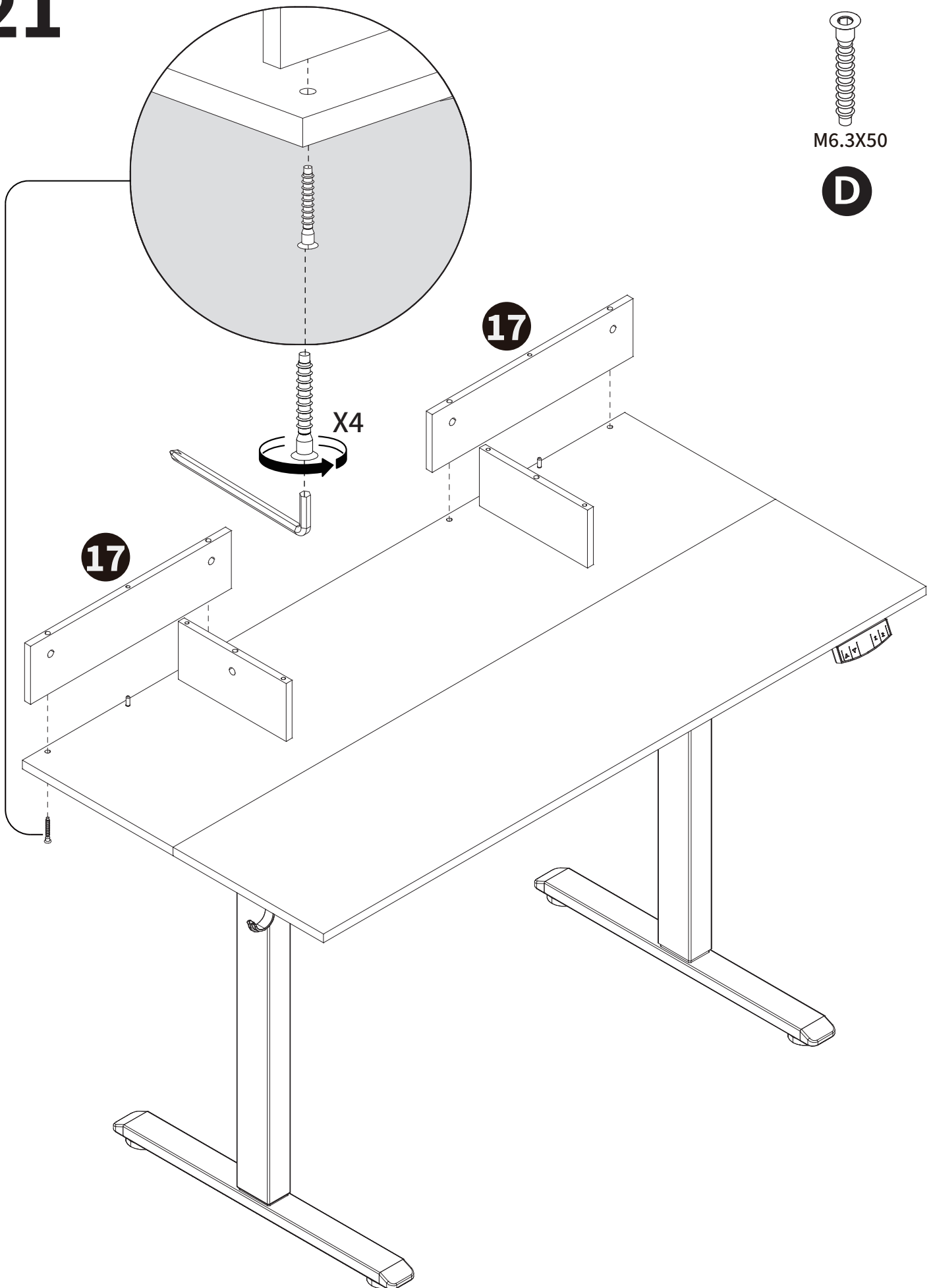

# 22

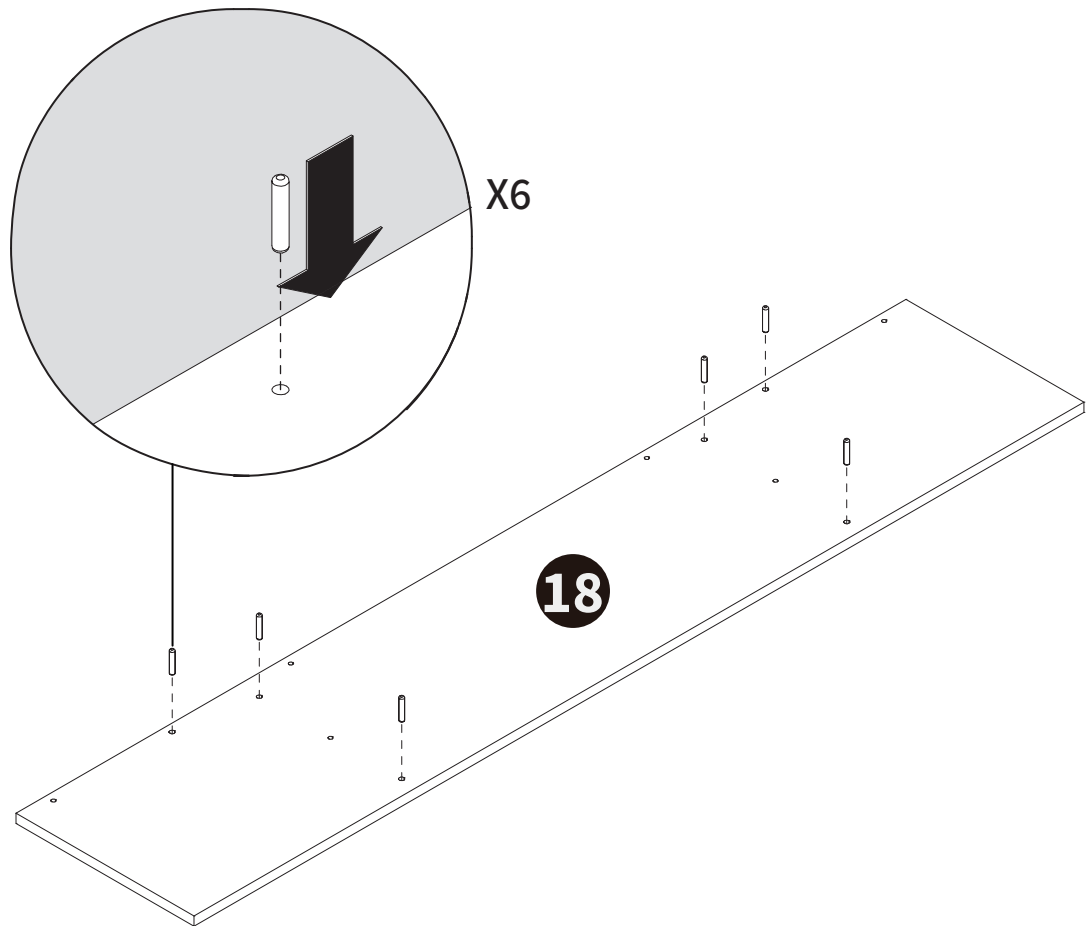

# 23

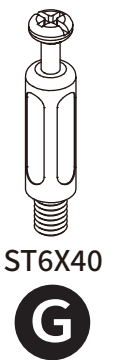
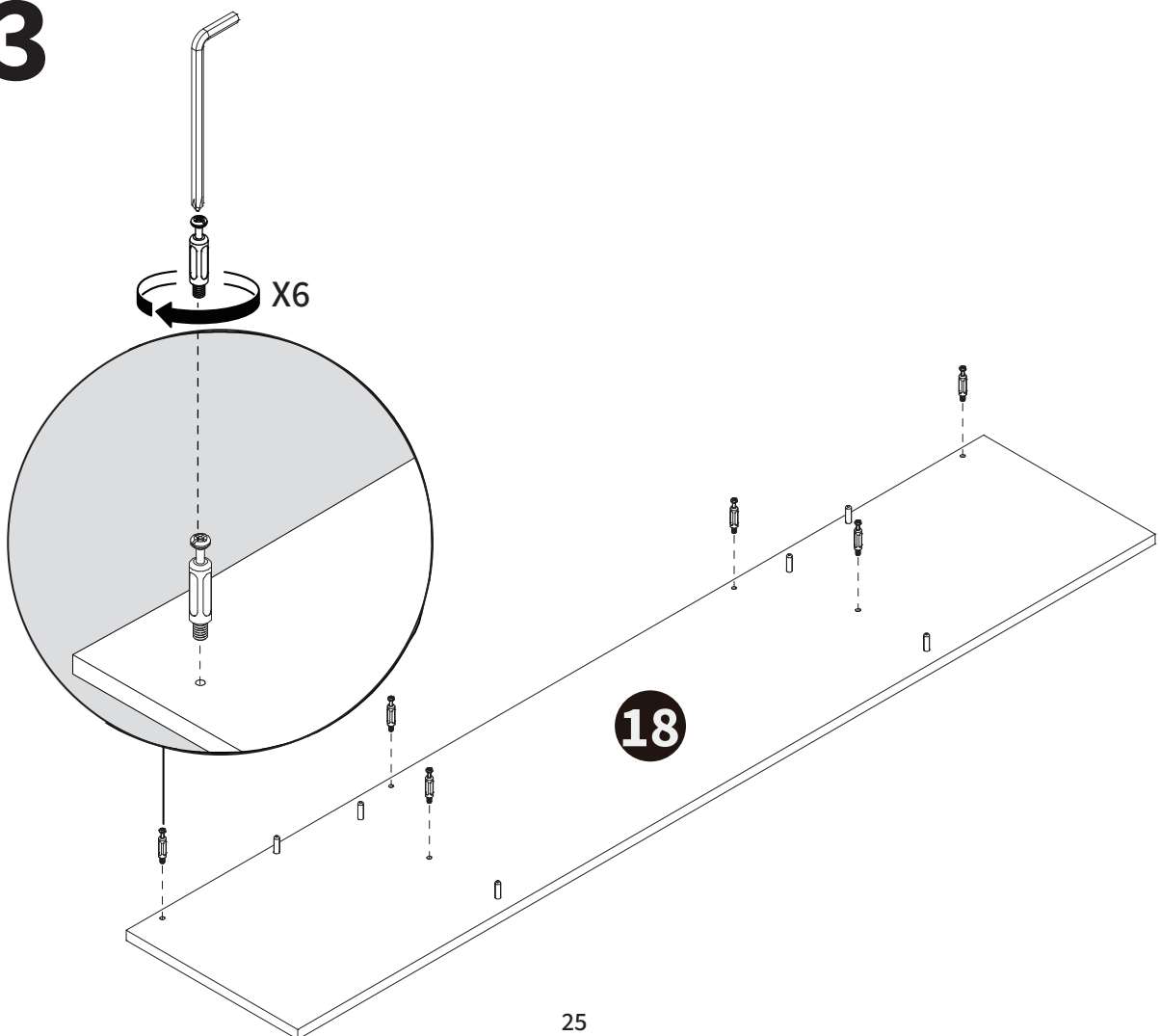

# 24

①

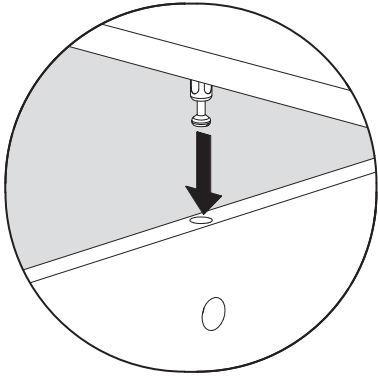

②

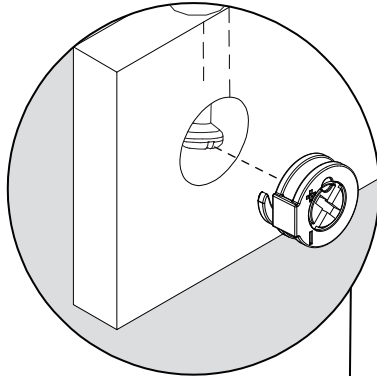

③

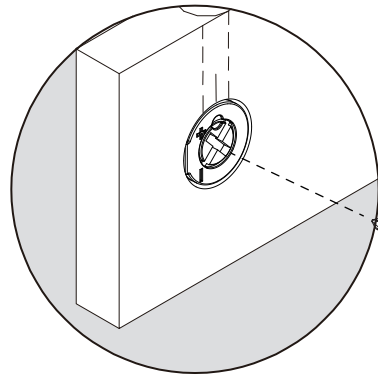

④

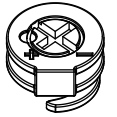
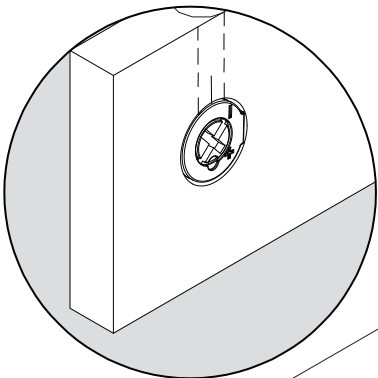

φ 12

H

X6

18

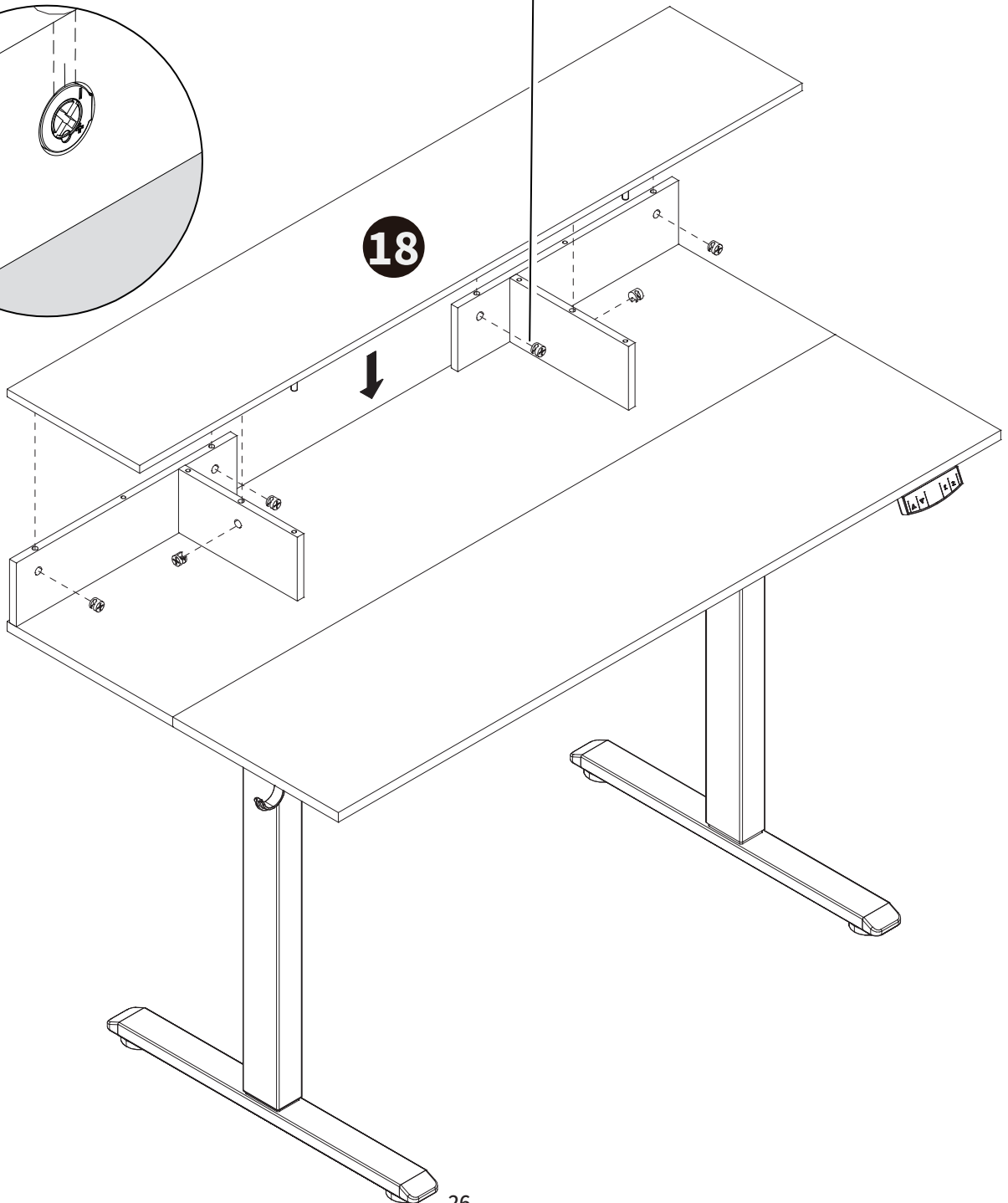

# 25

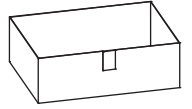

**P**

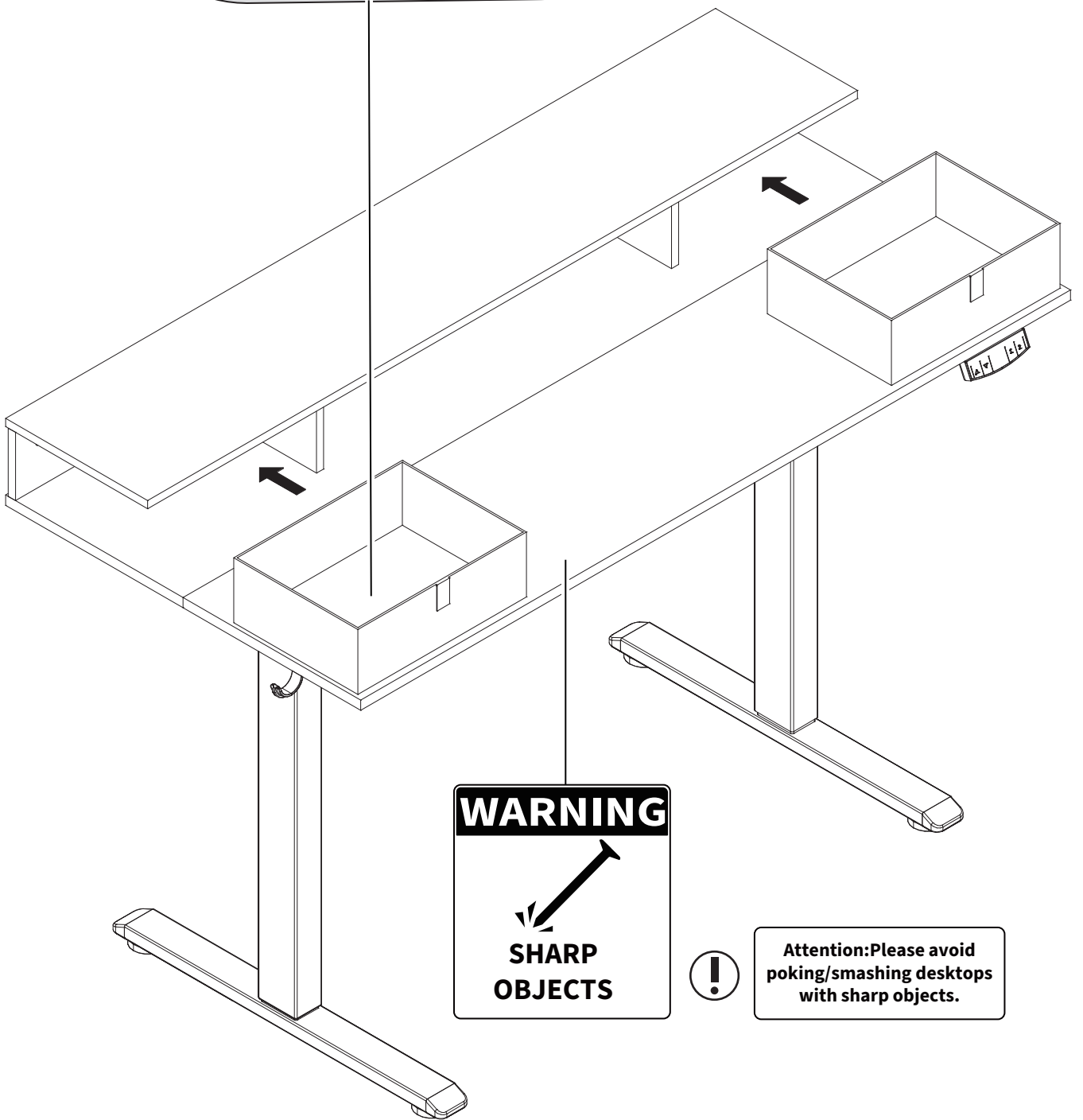
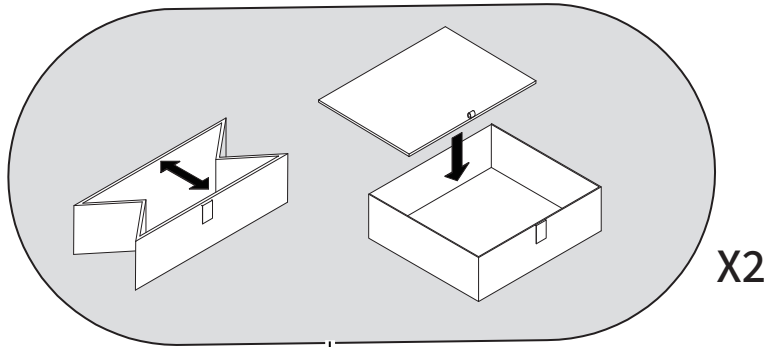

**WARNING**

**SHARP OBJECTS**



**Attention: Please avoid poking/smashing desktops with sharp objects.**

## Controller Operation Instructions

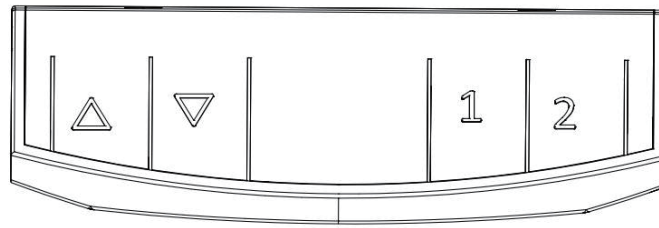

English(EN)

Using the controller

Raise the desktop	Press and hold the ▲ key to raise the desktop,and the table will stop moving when the key is released once the surface reaches the suitable height,or it will stop automatically when it reaches the highest position.
Lower the desktop	Press and hold the ▼ key to lower the desktop,and the table will stop moving when the key is released once the surface reaches the suitable height,or it will stop automatically when it reaches the lowest position.
Save current height setting	Press the number key(①, ②)for more than 2 seconds till H1 or H2 starts flashing to set this altitude as a pre-set height.
Memory height	In the height display interface,press ① or ② keys shortly then release,the standing table will automatically run to the memory height previously set for this key.
Power saving	If there is no key operation for a long time,the digital tube will automatically go out.At this time,press any key to light up the digital tube.

Setting menu

<p>Key-press sensitivity:</p> <ol style="list-style-type: none"> <li>1.Press the ① and ② keys at the same time for two seconds to display the current press-key force gear,3 seconds later,the digital screen will display the current height or press any key during the flashing to display the current height.</li> <li>2.If you need to adjust sensitivity value,please proceed in the above way;The sensitivity has 4 gears,and the adjustment sequence is :Off (off ),H(Heavy),N(Normal),L (Light),and repeat</li> </ol>
<p>Restore factory settings:</p> <p>In the cases that the "E10,E20"alarm state or after running to the lowest height position,long press the ▼ key for 3 seconds,then release when "rE5" is displayed.The standing desk will move down to the lowest and bounce to a certain height,the lowest height will displayed on the screen once the reset completes.Please notice that a stroke reset is required when the power is off for the first time.</p>

Protection and Alarm

<p>Anti-collision protection: E02</p>	<p>The alarm will be triggered and the moving is stopped automatically at once if there is any vibration,collision,or tilts during desk operation.Deactivate the alarm by operating the desktop reverse motion or pressing any key during the desktop reverse run.Notice that check and ensure the desk is moving without any vibrations,collisions,or tilts.</p>
<p>Overheat protection Hot</p>	<p>Overheat protection:Hot:Long-time running may trigger overheat protection.Please power it on again or wait more than 15 minutes before using the desk.</p>
<p>Motor abnormality protection E10</p>	<p>In the case of power failure,re-check and ensure that the connection between the power supply and the controller is proper,and then re-power on.</p>
<p>Overload protection E20</p>	<p>If this alarm occurs when running upward,heavy objects on the desktop should be moved before running again;if this alarm occurs when running downward,cut off the power,remove some heavy objects on the table,and then power on again.</p>
<p>Under voltage protection E31</p>	<p>In the case of power failure,re-check and ensure that the connection between the power supply and the controller is proper,and then re-power on.</p>
<p>Overvoltage protection E32</p>	<p>In the case of power failure,re-check and ensure that the connection between the power supply and the controller is proper,and then re-power on.</p>

Heben Sie den Schreibtisch an	Drücken und halten Sie die "▲"-Taste, um den Schreibtisch zu heben. Der Tisch wird anhalten, wenn die Taste losgelassen wird, sobald die Oberfläche die geeignete Höhe erreicht hat, oder er wird automatisch stoppen, wenn er die höchste Position erreicht hat.
Senken Sie den Schreibtisch ab	Drücken und halten Sie die "▼"-Taste, um den Schreibtisch zu senken. Der Tisch wird anhalten, wenn die Taste losgelassen wird, sobald die Oberfläche die geeignete Höhe erreicht hat, oder er wird automatisch stoppen, wenn er die niedrigste Position erreicht hat.
Aktuelle Höheneinstellung speichern	Drücken Sie die Zahlentaste (①, ②) für mehr als 2 Sekunden, bis H1 oder H2 zu blinken beginnt, um diese Höhe als voreingestellte Höhe festzulegen.
Gedächtnishöhe	Drücken Sie in der Höhenanzeige-Schnittstelle kurz die Tasten ① oder ② und lassen Sie sie dann los. Der Stehtisch wird automatisch zur zuvor für diesen Schlüssel eingestellten Speicherhöhe fahren.
Strom sparen	Wenn keine Taste lange Zeit nicht betätigt wird, wird die digitale Röhre automatisch ausgehen. Drücken Sie zu diesem Zeitpunkt eine beliebige Taste, um die digitale Röhre zu beleuchten.

## Setting menu

<p>Empfindlichkeit beim Tastendruck:</p> <ol style="list-style-type: none"> <li>1. Drücken Sie die "①"- und "②"-Tasten gleichzeitig für zwei Sekunden, um das aktuelle Druck-Tasten-Kraftgetriebe anzuzeigen. 3 Sekunden später wird der digitale Bildschirm die aktuelle Höhe anzeigen oder drücken Sie eine beliebige Taste während des Blinkens, um die aktuelle Höhe anzuzeigen.</li> <li>2. Wenn Sie den Empfindlichkeitswert anpassen müssen, gehen Sie bitte wie oben beschrieben vor. Die Empfindlichkeit hat 4 Gänge, und die Einstellungsreihenfolge lautet: Off (aus), H (schwer), N (normal), L (leicht), und wiederholen.</li> </ol>
<p>Werkseinstellungen wiederherstellen:</p> <p>Drücken Sie in den Fällen, in denen der "E10, E20"-Alarmzustand vorliegt oder nachdem der niedrigste Höhenposition erreicht wurde, die "▼"-Taste für 3 Sekunden, und lassen Sie sie dann los, wenn "rE5" angezeigt wird. Der Stehtisch wird sich zur niedrigsten Position bewegen und auf eine bestimmte Höhe springen. Die niedrigste Höhe wird auf dem Bildschirm angezeigt, sobald das Zurücksetzen abgeschlossen ist. Bitte beachten Sie, dass ein Hubreset erforderlich ist, wenn der Strom zum ersten Mal ausgeschaltet wird.</p>

## Protection and Alarm

Anti Kollisionsschutz E02	Der Alarm wird ausgelöst, und die Bewegung wird automatisch gestoppt, wenn während des Betriebs Vibrationen, Kollisionen oder Neigungen des Schreibtisches auftreten. Deaktivieren Sie den Alarm, indem Sie die Rückwärtsbewegung des Schreibtisches ausführen oder eine beliebige Taste während der Rückwärtsbewegung des Schreibtisches drücken. Stellen Sie sicher, dass der Schreibtisch ohne Vibrationen, Kollisionen oder Neigungen läuft.
überhitzen-Schützen Hot	Bei längerem Betrieb kann der Überhitzungsschutz auslösen. Bitte schalten Sie es erneut ein oder warten Sie mehr als 15 Minuten, bevor Sie den Schreibtisch verwenden.
Schutz vor Motoranomalien E10	Im Falle eines Stromausfalls überprüfen Sie bitte und stellen Sie sicher, dass die Verbindung zwischen der Stromversorgung und dem Controller korrekt ist, und schalten Sie dann erneut ein.
Überlast-Schützen E20	Wenn dieser Alarm beim Hochlaufen auftritt, sollten schwere Gegenstände auf dem Schreibtisch bewegt werden, bevor er erneut gestartet wird. Wenn dieser Alarm beim Abwärtslaufen auftritt, schalten Sie die Stromversorgung aus, entfernen Sie einige schwere Gegenstände auf dem Tisch und schalten Sie dann erneut ein.
Schutz vor Unterspannung E31	Im Falle eines Stromausfalls überprüfen Sie bitte und stellen Sie sicher, dass die Verbindung zwischen der Stromversorgung und dem Controller korrekt ist, und schalten Sie dann erneut ein.
Schutz vor Überspannung E32	Im Falle eines Stromausfalls überprüfen Sie bitte und stellen Sie sicher, dass die Verbindung zwischen der Stromversorgung und dem Controller korrekt ist, und schalten Sie dann erneut ein.

Soulevez le bureau	Appuyez et maintenez la touche "▲" pour soulever le bureau, et la table s'arrêtera de bouger lorsque la touche sera relâchée une fois la surface atteignant la hauteur appropriée, ou elle s'arrêtera automatiquement lorsqu'elle atteindra la position la plus haute.
Abaissez le bureau	Appuyez et maintenez la touche "▼" pour abaisser le bureau, et la table s'arrêtera de bouger lorsque la touche sera relâchée une fois la surface atteignant la hauteur appropriée, ou elle s'arrêtera automatiquement lorsqu'elle atteindra la position la plus basse.
Enregistrez la hauteur actuelle	Appuyez sur la touche numérique (①, ②) pendant plus de 2 secondes jusqu'à ce que H1 ou H2 commence à clignoter pour définir cette hauteur comme hauteur prédéfinie.
Hauteur mémorisée	Dans l'interface d'affichage de la hauteur, appuyez brièvement sur les touches ① ou ②, puis relâchez-les. La table debout se déplacera automatiquement à la hauteur mémorisée précédemment définie pour cette touche.
Économie d'énergie	En l'absence d'opération de touche pendant longtemps, le tube numérique s'éteindra automatiquement. À ce moment-là, appuyez sur n'importe quelle touche pour allumer le tube numérique.

## Menu de réglage

<p>Sensibilité de la touche:</p> <ol style="list-style-type: none"> <li>Appuyez sur les touches "①" et "②" en même temps pendant deux secondes pour afficher l'engrenage de force de la touche actuelle, 3 secondes plus tard, l'écran numérique affichera la hauteur actuelle ou appuyez sur n'importe quelle touche pendant le clignotement pour afficher la hauteur actuelle.</li> <li>Si vous avez besoin d'ajuster la valeur de sensibilité, veuillez procéder comme ci-dessus. La sensibilité a 4 niveaux, et la séquence d'ajustement est : Off (éteint), H (lourd), N (normal), L (léger), et répétez.</li> </ol>
<p>Restaurer les paramètres d'usine:</p> <p>Dans les cas où l'état d'alarme "E10, E20" est activé ou après être descendu à la position la plus basse, maintenez la touche "▼" enfoncée pendant 3 secondes, puis relâchez-la lorsque "rE5" s'affiche. La table debout descendra jusqu'à la position la plus basse et rebondira à une certaine hauteur, la hauteur la plus basse sera affichée à l'écran une fois la réinitialisation terminée. Veuillez noter qu'une réinitialisation de course est nécessaire lorsque l'alimentation est coupée pour la première fois.</p>

## Protection et alarme

Protection anti-collision E02	L'alarme sera déclenchée et le mouvement sera automatiquement arrêté s'il y a des vibrations, des collisions ou des inclinaisons pendant le fonctionnement du bureau. Désactivez l'alarme en opérant le mouvement inverse du bureau ou en appuyant sur n'importe quelle touche pendant le mouvement inverse du bureau. Assurez-vous que le bureau fonctionne sans vibrations, collisions ou inclinaisons.
Protection contre la surchauffe Hot	Un fonctionnement prolongé peut déclencher une protection contre la surchauffe. Veuillez le réallumer ou attendre plus de 15 minutes avant d'utiliser le bureau.
Protection contre les anomalies du moteur E10	En cas de panne de courant, vérifiez et assurez-vous que la connexion entre l'alimentation et le contrôleur est correcte, puis rallumez..
Protection contre les surcharges E20	Si cette alarme se déclenche lors d'une montée, des objets lourds sur le bureau doivent être déplacés avant de relancer; si cette alarme se déclenche lors d'une descente, coupez l'alimentation, retirez certains objets lourds sur la table, puis rallumez.
Protection contre la sous-tension E31	En cas de panne de courant, vérifiez et assurez-vous que la connexion entre l'alimentation et le contrôleur est correcte, puis rallumez.
Protection contre la surtension E32	En cas de panne de courant, vérifiez et assurez-vous que la connexion entre l'alimentation et le contrôleur est correcte, puis rallumez.

Solleva il desktop	Premi e tieni premuto il tasto "▲" per sollevare il desktop, e il tavolo smetterà di muoversi quando il tasto viene rilasciato una volta che la superficie raggiunge l'altezza adatta, o si fermerà automaticamente quando raggiunge la posizione più alta.
Abbassa il desktop	Premi e tieni premuto il tasto "▼" per abbassare il desktop, e il tavolo smetterà di muoversi quando il tasto viene rilasciato una volta che la superficie raggiunge l'altezza adatta, o si fermerà automaticamente quando raggiunge la posizione più bassa
Salva l'impostazione dell'altezza attuale	Premi il tasto numerico (①, ②) per più di 2 secondi fino a quando H1 o H2 inizia a lampeggiare per impostare questa altezza come altezza preimpostata.
Altezza memorizzata	Nell'interfaccia di visualizzazione dell'altezza, premi brevemente i tasti ① o ② e rilasciali, il tavolo in piedi si muoverà automaticamente all'altezza memorizzata precedentemente impostata per questa chiave.
Risparmio energetico	Se non ci sono operazioni di tastiera per molto tempo, il tubo digitale si spegnerà automaticamente. In questo momento, premi qualsiasi tasto per accendere il tubo digitale.

## Menù di impostazione

<p>Sensibilità della pressione del tasto:</p> <ol style="list-style-type: none"> <li>1. Premi contemporaneamente i tasti "①" e "②" per due secondi per visualizzare l'ingranaggio di forza attuale della pressione del tasto, 3 secondi dopo, lo schermo digitale visualizzerà l'altezza attuale o premi qualsiasi tasto durante il lampeggiamento per visualizzare l'altezza attuale.</li> <li>2. Se è necessario regolare il valore di sensibilità, procedere come sopra; La sensibilità ha 4 marce, e la sequenza di regolazione è: Off (off), H (pesante), N (normale), L (leggero), e ripetere.</li> </ol>
<p>Ripristina le impostazioni di fabbrica:</p> <p>Nei casi in cui lo stato di allarme "E10, E20" è attivo o dopo essere scesi alla posizione più bassa, premi a lungo il tasto "▼" per 3 secondi, quindi rilascialo quando viene visualizzato "rE5". Il tavolo in piedi scenderà alla posizione più bassa e rimbalzerà a una certa altezza, l'altezza più bassa verrà visualizzata sullo schermo una volta completato il ripristino. Si prega di notare che è necessario un reset del corso quando l'alimentazione è spenta per la prima volta.</p>

## Protezione e allarme

Protezione anticollisione E02	L'allarme verrà attivato e il movimento verrà automaticamente arrestato se ci sono vibrazioni, collisioni o inclinazioni durante il funzionamento del tavolo. Disattiva l'allarme operando il movimento inverso del desktop o premendo qualsiasi tasto durante il movimento inverso del desktop. Assicurarsi che il desktop si muova senza vibrazioni, collisioni o inclinazioni.
Protezione da surriscaldamento Hot	Protezione da surriscaldamento: Caldo: un funzionamento prolungato può attivare la protezione da surriscaldamento. Si prega di riaccenderlo o di attendere più di 15 minuti prima di utilizzare il tavolo.
Protezione dall'anomalia del motore E10	In caso di interruzione di corrente, controllare e assicurarsi che la connessione tra l'alimentazione e il controller sia corretta, quindi riaccendere.
Protezione da sovraccarico E20	Se questo allarme si verifica durante la salita, spostare gli oggetti pesanti sul desktop prima di eseguire nuovamente; se questo allarme si verifica durante la discesa, interrompere l'alimentazione, rimuovere alcuni oggetti pesanti sul tavolo e quindi riaccendere.
Protezione da bassa tensione E31	In caso di interruzione di corrente, controllare e assicurarsi che la connessione tra l'alimentazione e il controller sia corretta, quindi riaccendere.
Protezione da sovratensione E32	In caso di interruzione di corrente, controllare e assicurarsi che la connessione tra l'alimentazione e il controller sia corretta, quindi riaccendere.

Elevar el escritorio	Presione y mantenga presionada la tecla "▲" para elevar el escritorio, y la mesa se detendrá cuando se suelte la tecla una vez que la superficie alcance la altura adecuada, o se detendrá automáticamente cuando alcance la posición más alta.
Bajar el escritorio	Presione y mantenga presionada la tecla "▼" para bajar el escritorio, y la mesa se detendrá cuando se suelte la tecla una vez que la superficie alcance la altura adecuada, o se detendrá automáticamente cuando alcance la posición más baja.
Guardar la configuración de altura actual	Presione la tecla numérica (1, 2) durante más de 2 segundos hasta que H1 o H2 comience a parpadear para establecer esta altura como altura preestablecida.
Altura de memoria	En la interfaz de visualización de altura, presione brevemente las teclas 1 o 2 y luego suéltelas, la mesa en posición de pie se moverá automáticamente a la altura de memoria previamente configurada para esta tecla.
Ahorro de energía	Si no hay operación de tecla durante mucho tiempo, el tubo digital se apagará automáticamente. En este momento, presione cualquier tecla para encender el tubo digital.

## Menú de configuración

<p>Sensibilidad de pulsación de teclas:</p> <ol style="list-style-type: none"> <li>1. Presione simultáneamente las teclas "1" y "2" durante dos segundos para mostrar la marcha actual de la fuerza de presión de la tecla, 3 segundos después, la pantalla digital mostrará la altura actual o presione cualquier tecla durante el parpadeo para mostrar la altura actual.</li> <li>2. Si necesita ajustar el valor de sensibilidad, proceda de la misma manera que arriba; la sensibilidad tiene 4 marchas, y la secuencia de ajuste es: Off (apagado), H (pesado), N (normal), L (ligero), y repetir.</li> </ol>
<p>Restaurar los ajustes de fábrica:</p> <p>En los casos en que el estado de alarma "E10, E20" está activado o después de llegar a la posición más baja, mantenga presionada la tecla "▼" durante 3 segundos, luego suelte cuando se muestre "rE5". El escritorio se moverá hacia abajo hasta la posición más baja y rebotará a cierta altura, la altura más baja se mostrará en la pantalla una vez que se complete el restablecimiento. Tenga en cuenta que se requiere un restablecimiento del recorrido cuando la alimentación está apagada por primera vez.</p>

## Protección y Alarma

<p>Anti Kollisionsschutz E02</p>	<p>La alarma se activará y el movimiento se detendrá automáticamente si hay vibraciones, colisiones o inclinaciones durante el funcionamiento del escritorio. Desactive la alarma operando el movimiento inverso del escritorio o presionando cualquier tecla durante el movimiento inverso del escritorio. Asegúrese de que el escritorio se esté moviendo sin vibraciones, colisiones o inclinaciones.</p>
<p>überhitzen-Schützen Hot</p>	<p>Protección contra sobrecalentamiento: Caliente: un funcionamiento prolongado puede activar la protección contra sobrecalentamiento. Por favor, enciéndalo nuevamente o espere más de 15 minutos antes de usar el escritorio.</p>
<p>Schutz vor Motoranomalien E10</p>	<p>En caso de fallo de alimentación, revise y asegúrese de que la conexión entre la fuente de alimentación y el controlador sea correcta, y luego vuelva a encenderla.</p>
<p>Überlast-Schützen E20</p>	<p>Si esta alarma ocurre al subir, los objetos pesados en el escritorio deben moverse antes de volver a funcionar; si esta alarma ocurre al bajar, corte la alimentación, retire algunos objetos pesados de la mesa y luego vuelva a encenderla.</p>
<p>Schutz vor Unterspannung E31</p>	<p>En caso de fallo de alimentación, revise y asegúrese de que la conexión entre la fuente de alimentación y el controlador sea correcta, y luego vuelva a encenderla.</p>
<p>Schutz vor Überspannung E32</p>	<p>En caso de fallo de alimentación, revise y asegúrese de que la conexión entre la fuente de alimentación y el controlador sea correcta, y luego vuelva a encenderla.</p>