

Assembly Instructions

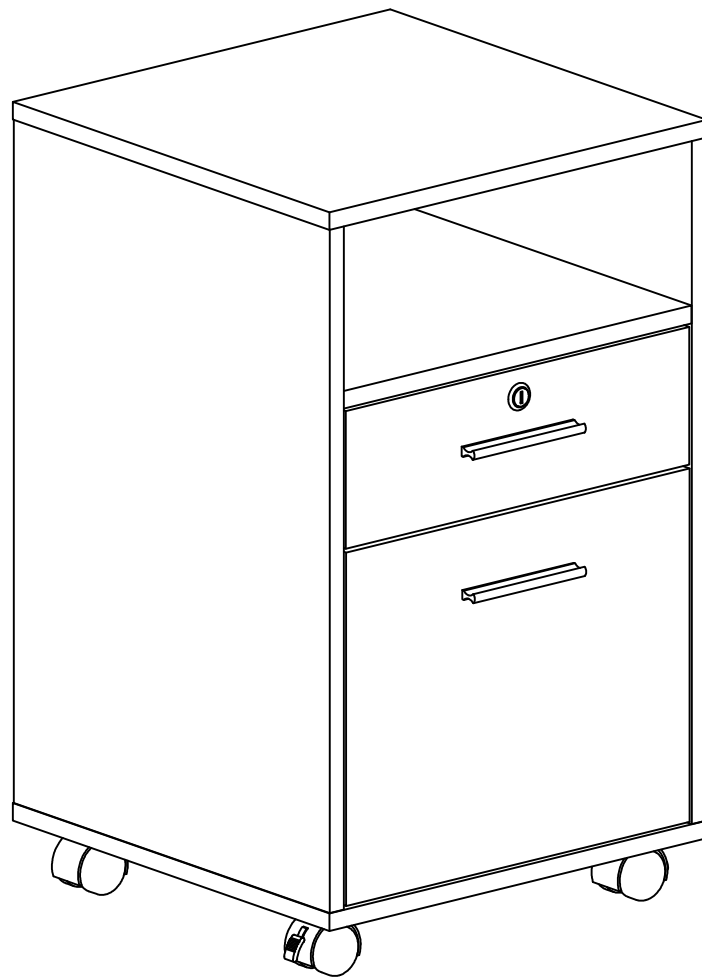

File Cabinet

Assembly Instructions:

1. Carefully read these instructions and keep them for future reference.
2. Refer to the parts list for guidance and ensure that you have all the pieces before starting the assembly process, if anything is missing, damaged, incorrect, contact us **FIRSTLY BEFORE** assembling.
3. When assembling, place all parts on a soft, clean, and flat surface, such as a carpet, to prevent any scratches.
4. To avoid misalignment of the holes, Please don't full tighten the screws until you ensure all parts in place.

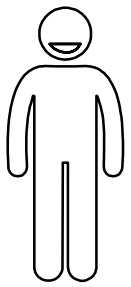

X2

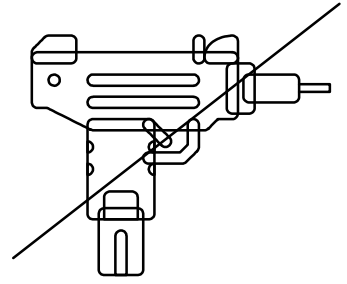
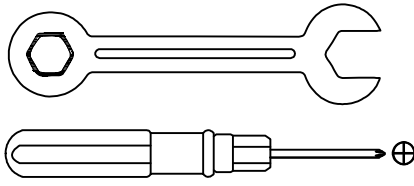

When using the electric screwdriver ,
Reduce the power and torque to avoid damaging the furniture

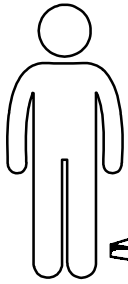

?

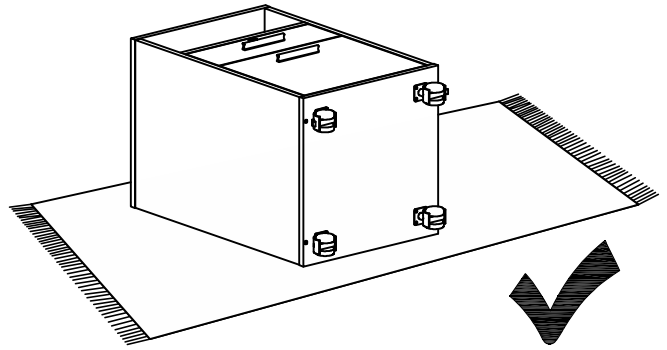
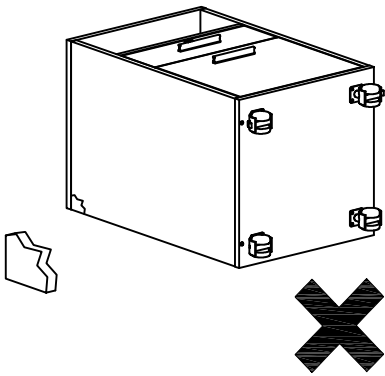
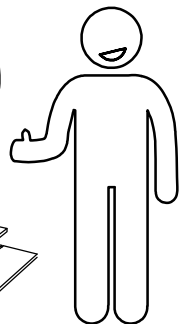
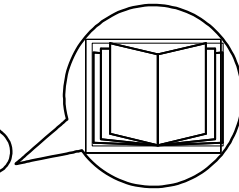
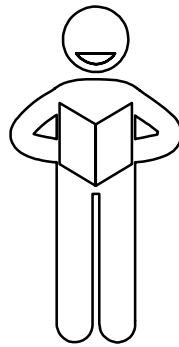
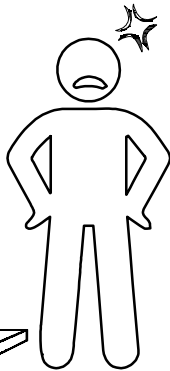

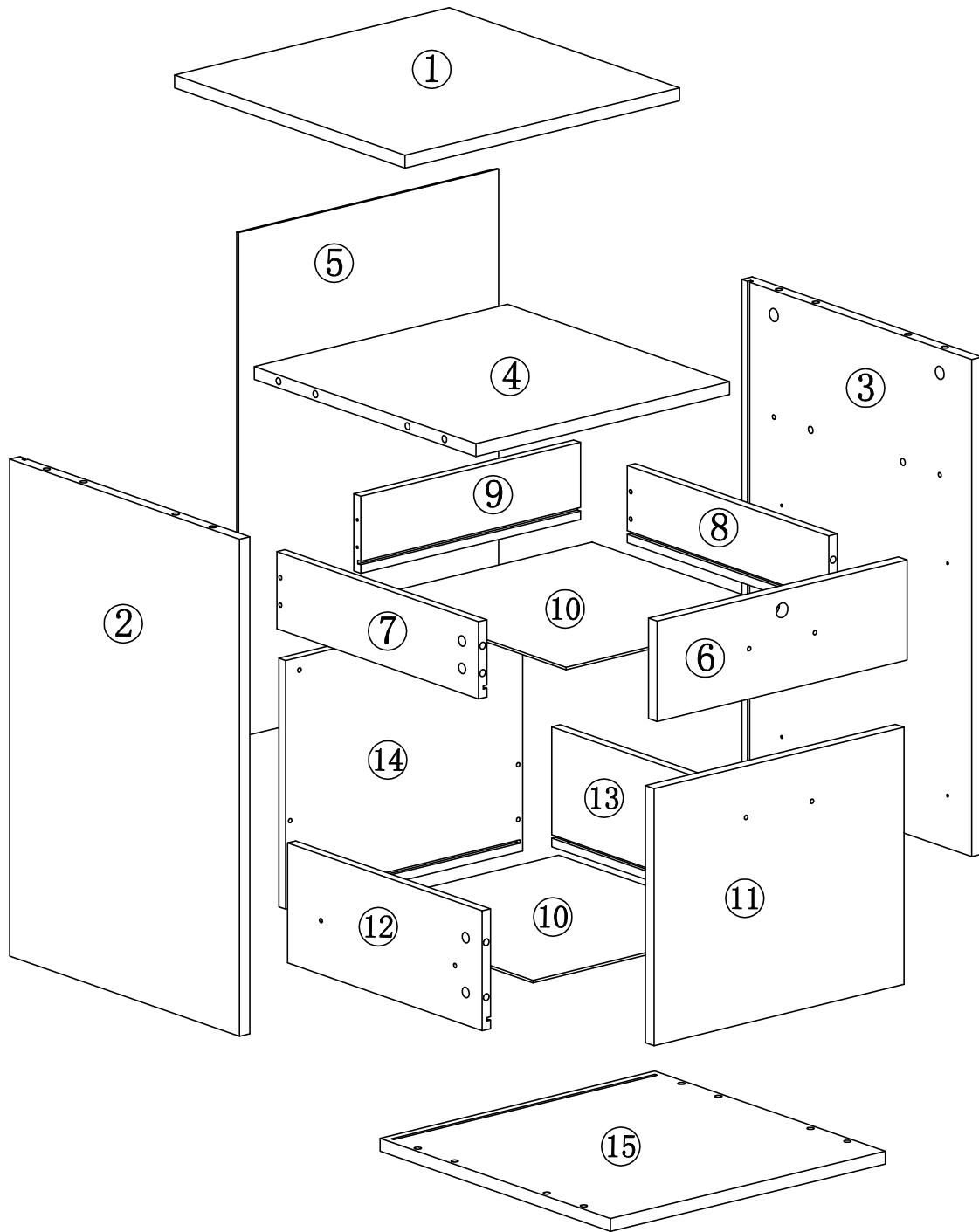

! Caution

Make sure all parts are included. Most board parts are labeled or stamped on the raw edge. Contact us for free replacement if having damaged or missing parts.

Parts & Hardware List

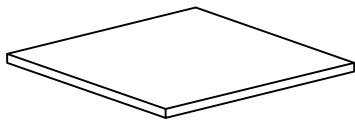

① 1pc

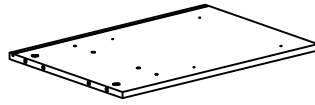

② 1pc

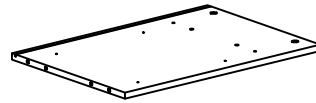

③ 1pc

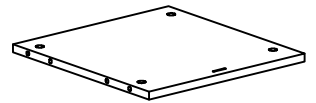

④ 1pc

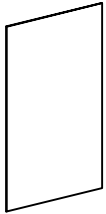

⑤ 1pc

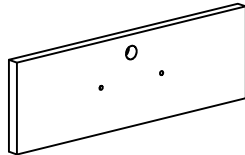

⑥ 1pc

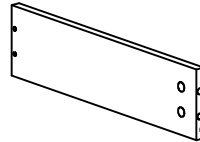

⑦ 1pc

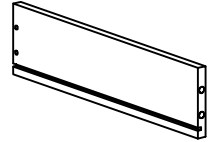

⑧ 1pc

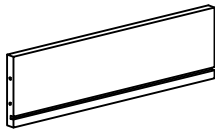

⑨ 1pc

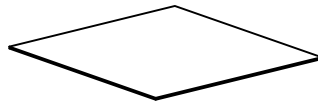

⑩ 2pcs

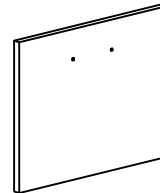

⑪ 1pc

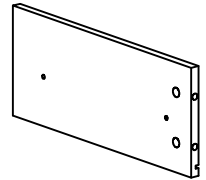

⑫ 1pc

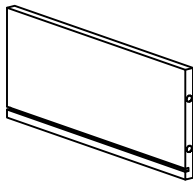

⑬ 1pc

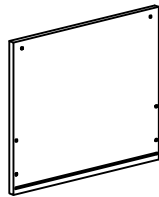



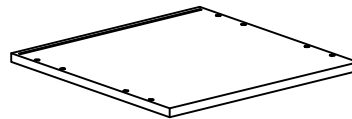





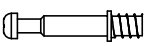



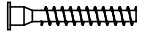



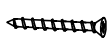

⑭ 1pc

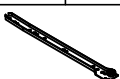
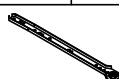

⑮ 1pc

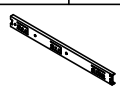
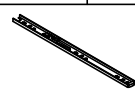
Hardware List

A	X16+1	B	X8+1	C	X8+1	D	X12+1	E	X4+1	F	X1	G	X32+1
													
φ 6X35	φ 15X12	φ 15X10	φ 8X30	φ 7X47	M4X55	3.5*14mm							
H	X4+1	I	X8+1	J	X4+1	K	X2	L	X2	M	X2	N	X1
													
3.5*18mm	φ4*35mm	M4*18mm	104*16*8mm	φ 50	φ 50	36*36mm							
O	X1	P	X1	Q	X1	R	X1	S	X2	T	X2	U	X2
													
L350mm	L350mm	L350mm	L350mm	L350mm	L350mm	L350mm							

Installation of Cams and Pins

Screw the pin into the hole. To set the cams correctly, ensure that the arrow on the cam is opening to the hole of the pin it is locking. Lock the cam by turning the cam head with a screwdriver until it is tightened. Please do not use an electric screwdriver to assemble the unit.

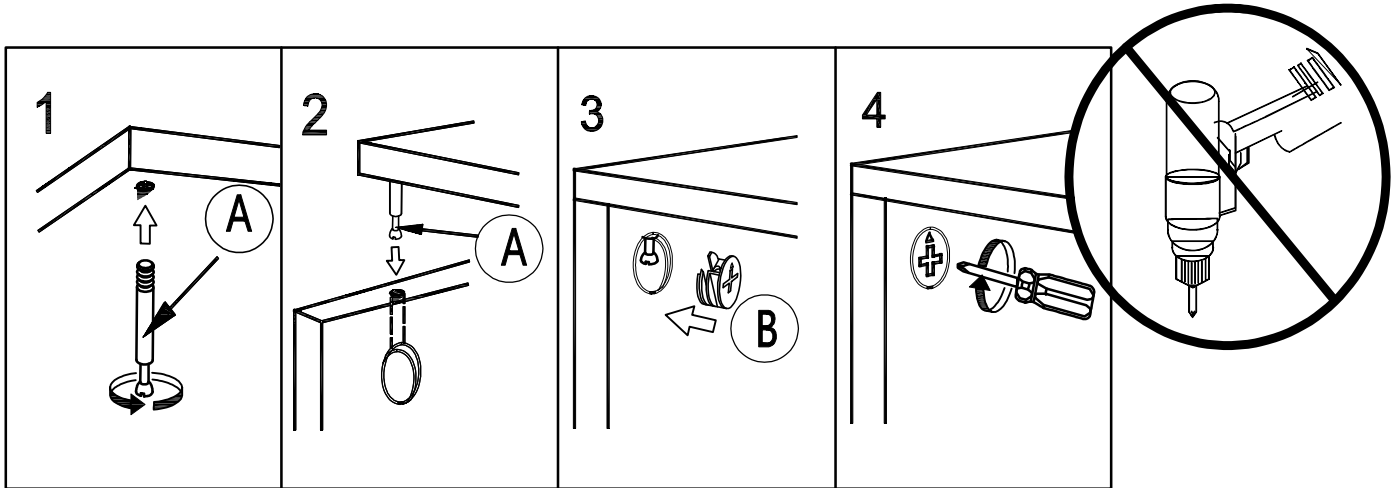

Read each step carefully before starting. It is very important that each step of instruction is performed in the correct order. If these steps are not followed in sequence, assembly difficulties will occur.

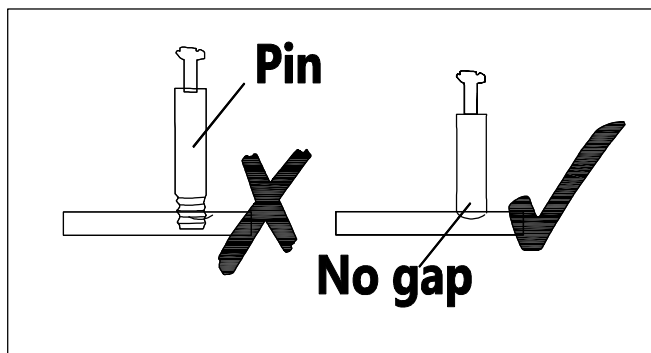

①

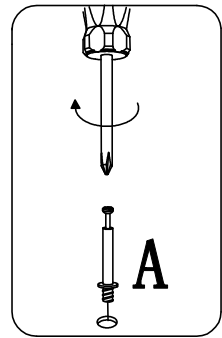
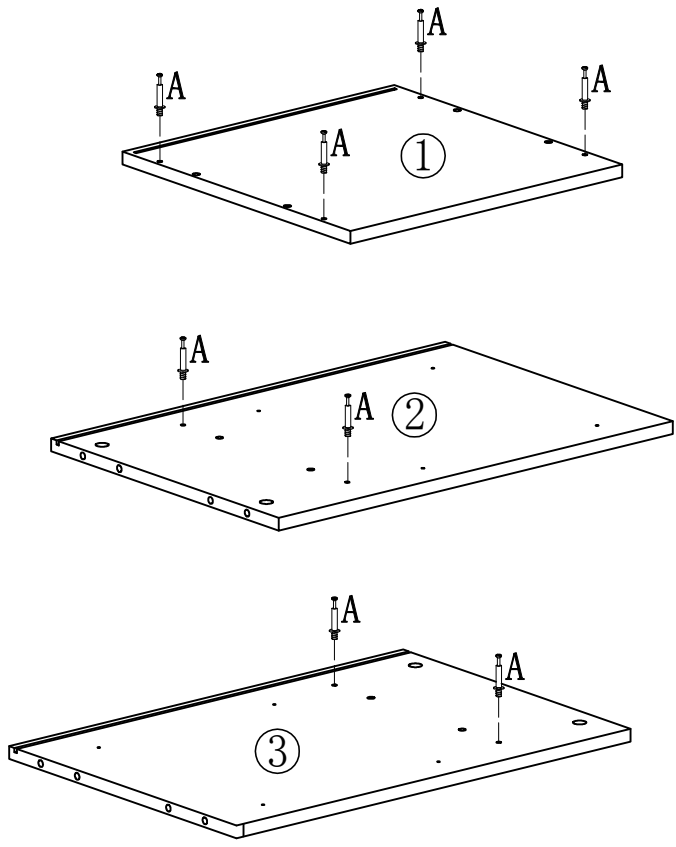

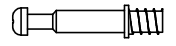
A	X8
	
Φ 6X35	

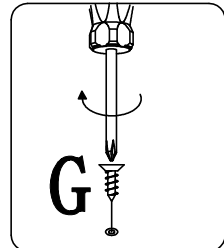
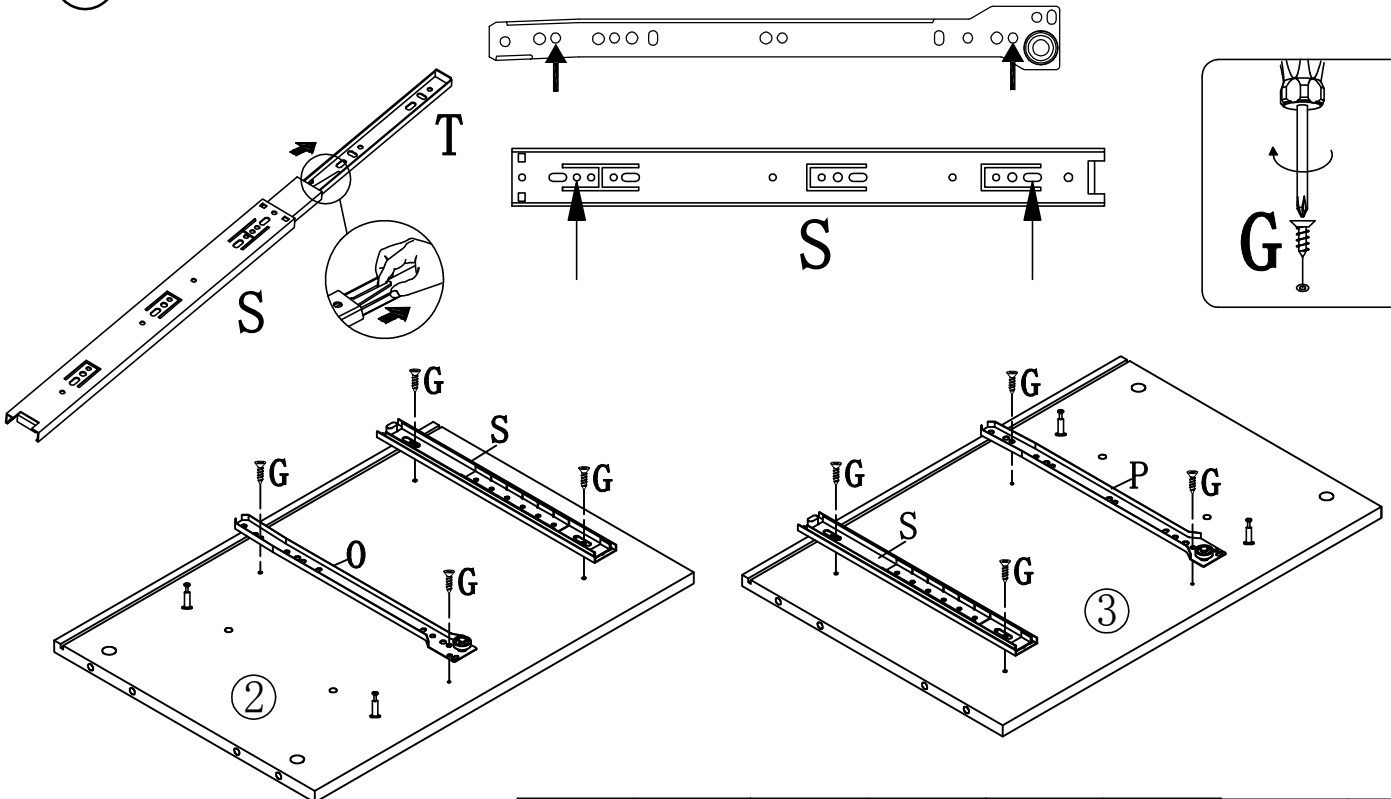

②

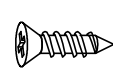
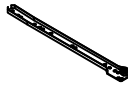
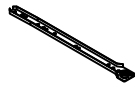
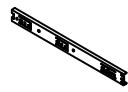

G	X8	O	X1	P	X1	S	X2
							
3.5*14mm		L350mm		L350mm		L350mm	

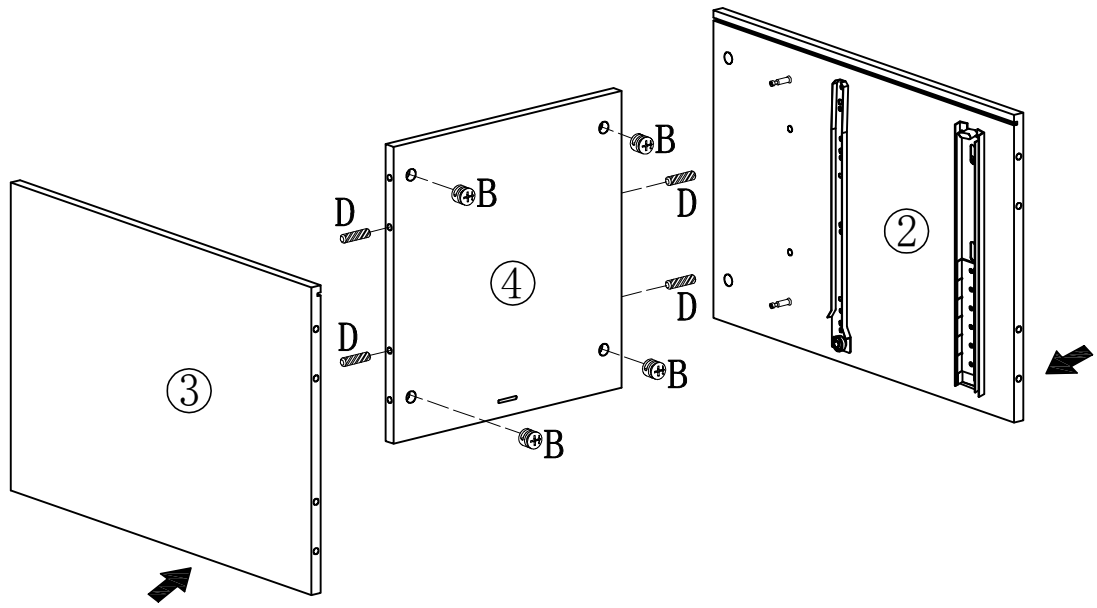

3



B	X4	D	X4
			
φ 15X12		φ 8X30	

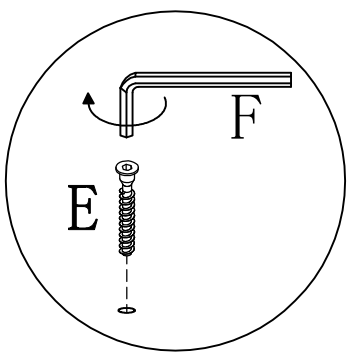
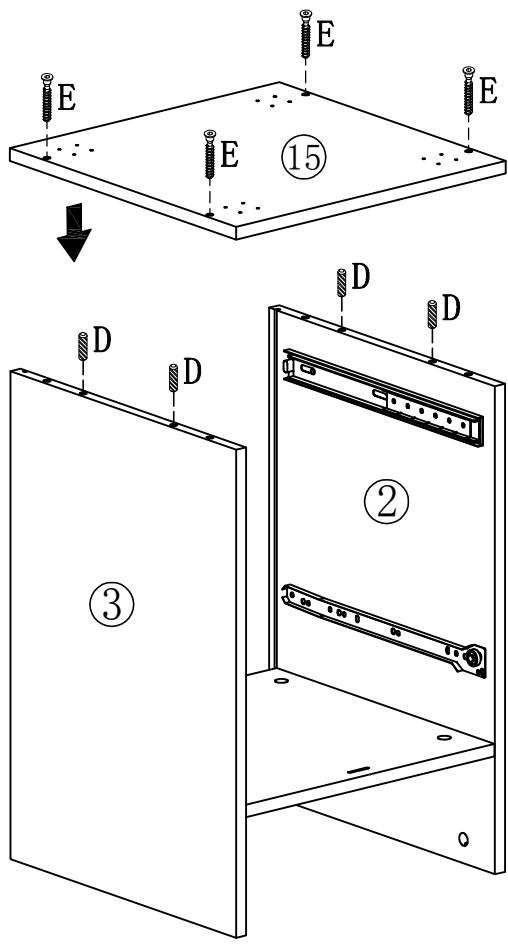

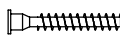
4

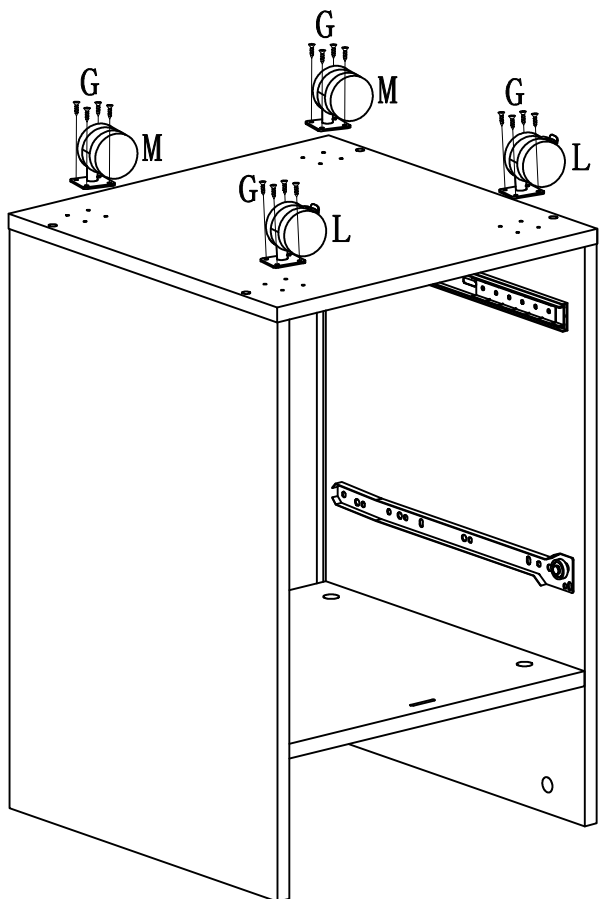

D	X4	E	X4	F	X1
					
φ 8X30		φ 7X47		M4X55	

5



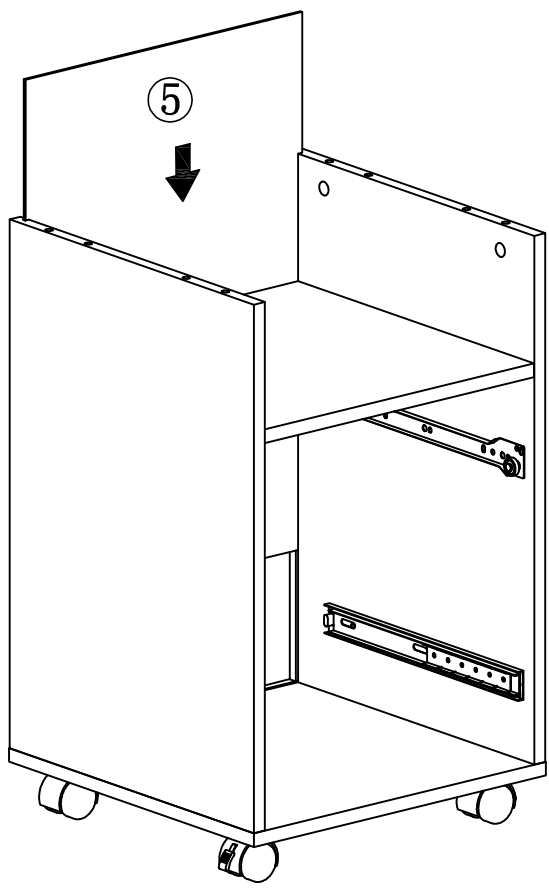

G	X16	L	X2	M	X2
					
ø3.5*14mm		ø50mm		ø50mm	

6



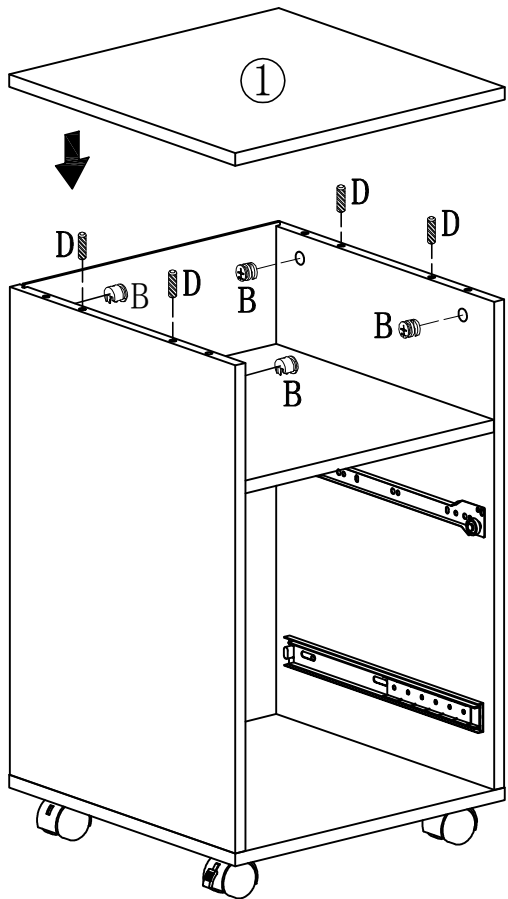

7

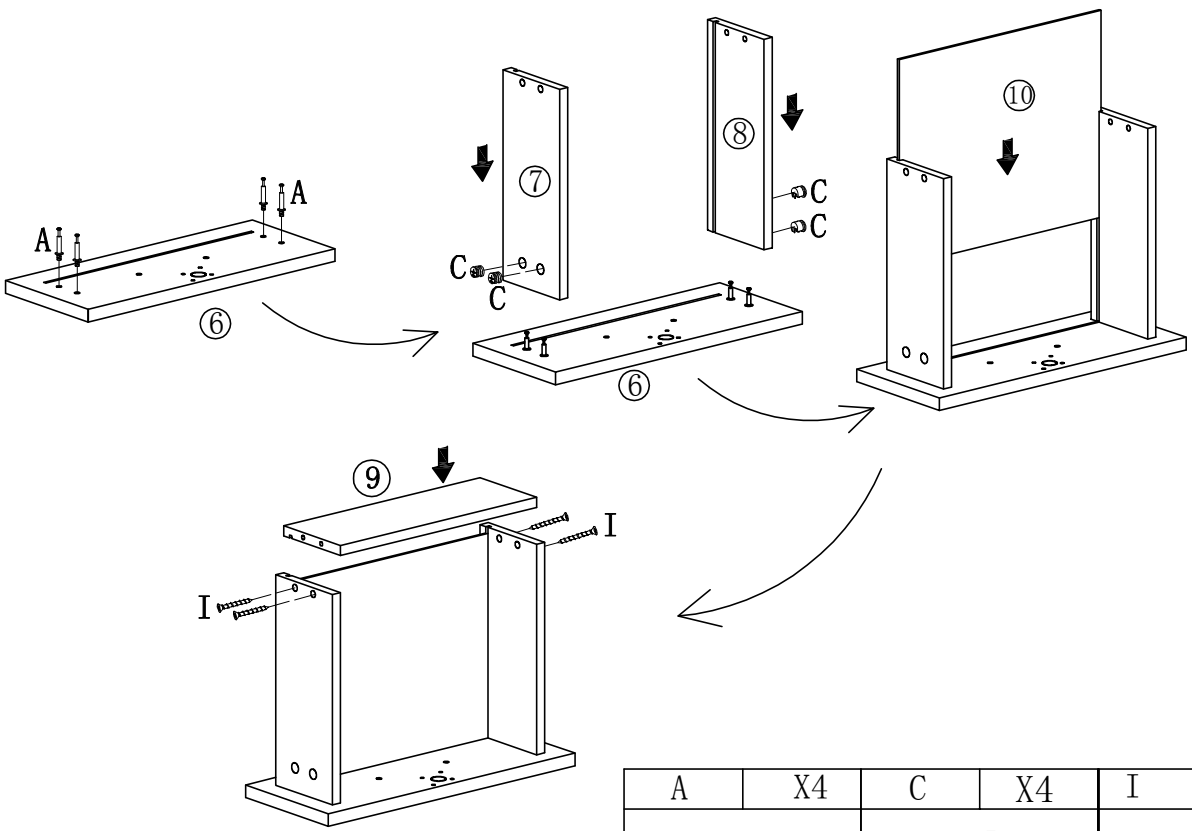

B	X4	D	X4
			
φ 15X12		φ 8X30	

8

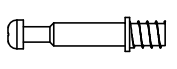

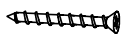
A	X4	C	X4	I	X4
					
φ 6X35		φ 15X10		ø4*35mm	

9

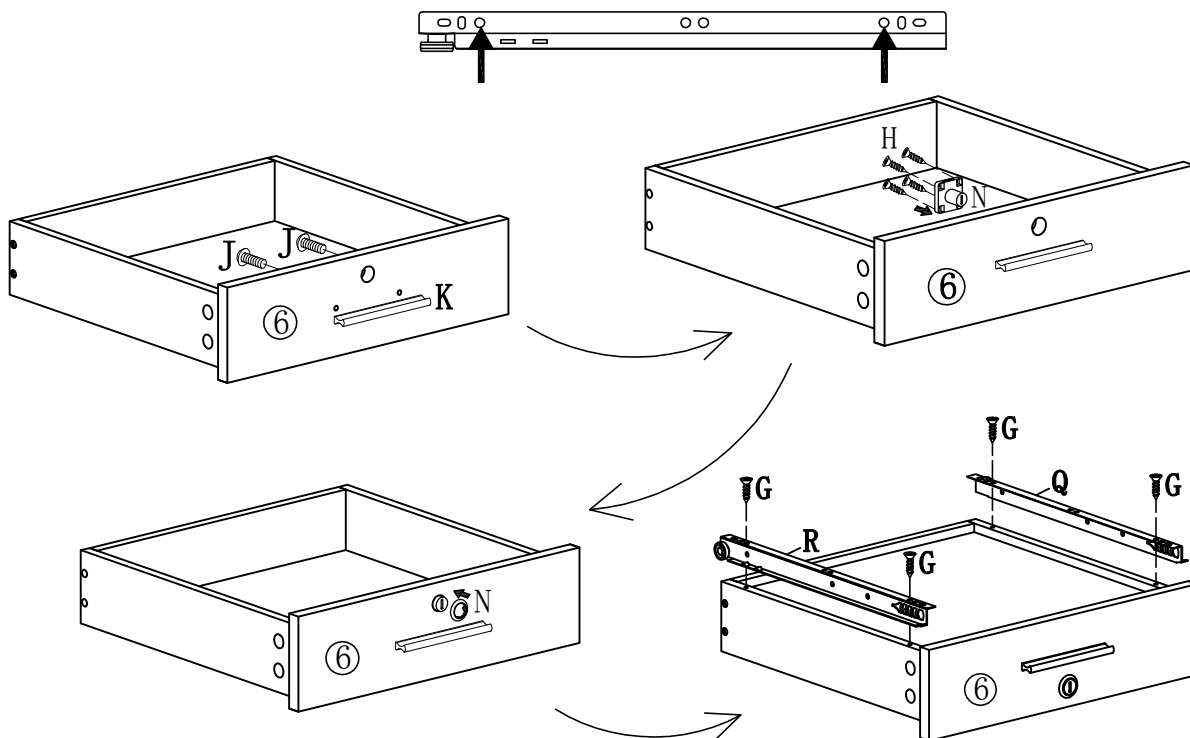

G	X4	H	X4	J	X2	K	X1	N	X1	Q	X1	R	X1
3.5*14mm		3.5*18mm		M4*18mm		104*16*8mm		36*36mm		L350mm		L350mm	

10

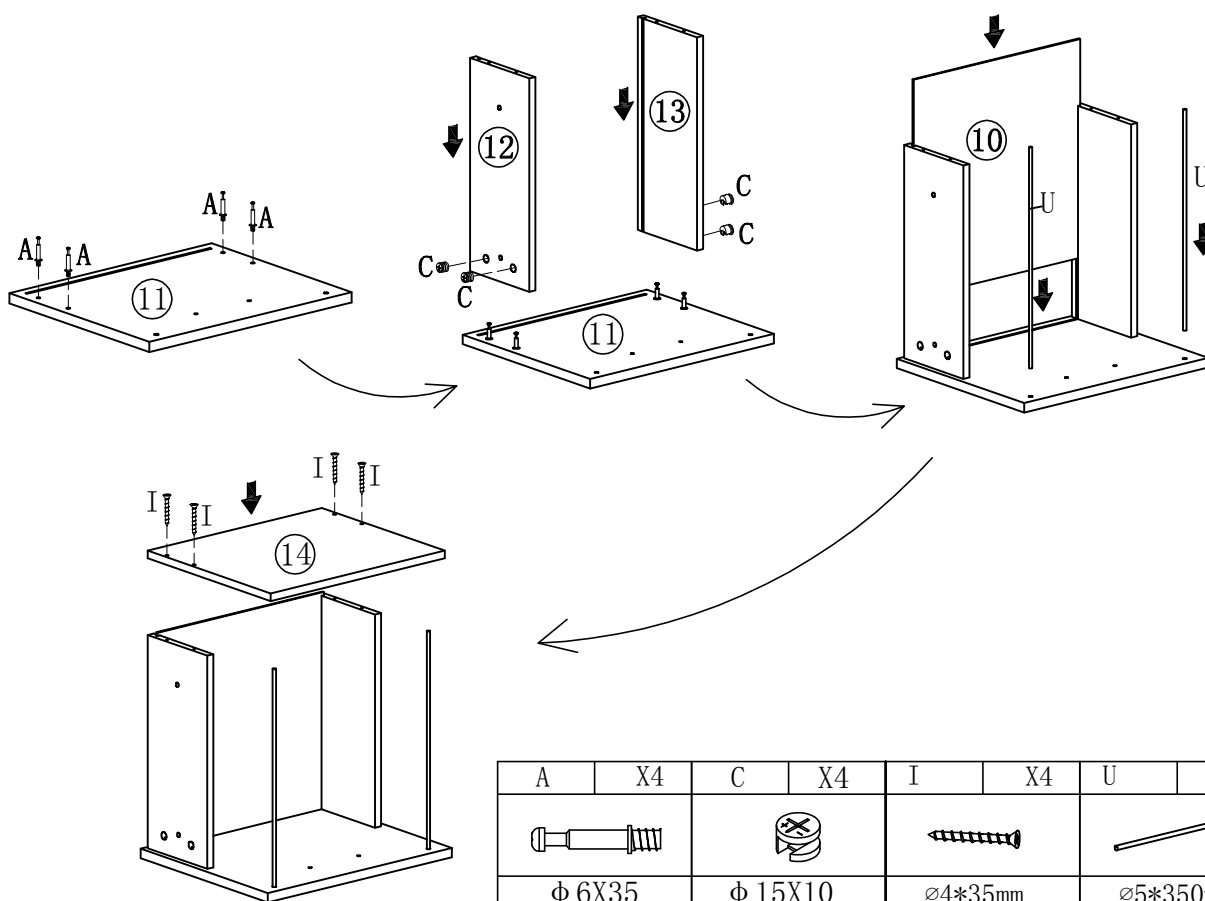

A	X4	C	X4	I	X4	U	X2
Φ 6X35		Φ 15X10		Ø4*35mm		Ø5*350mm	

11

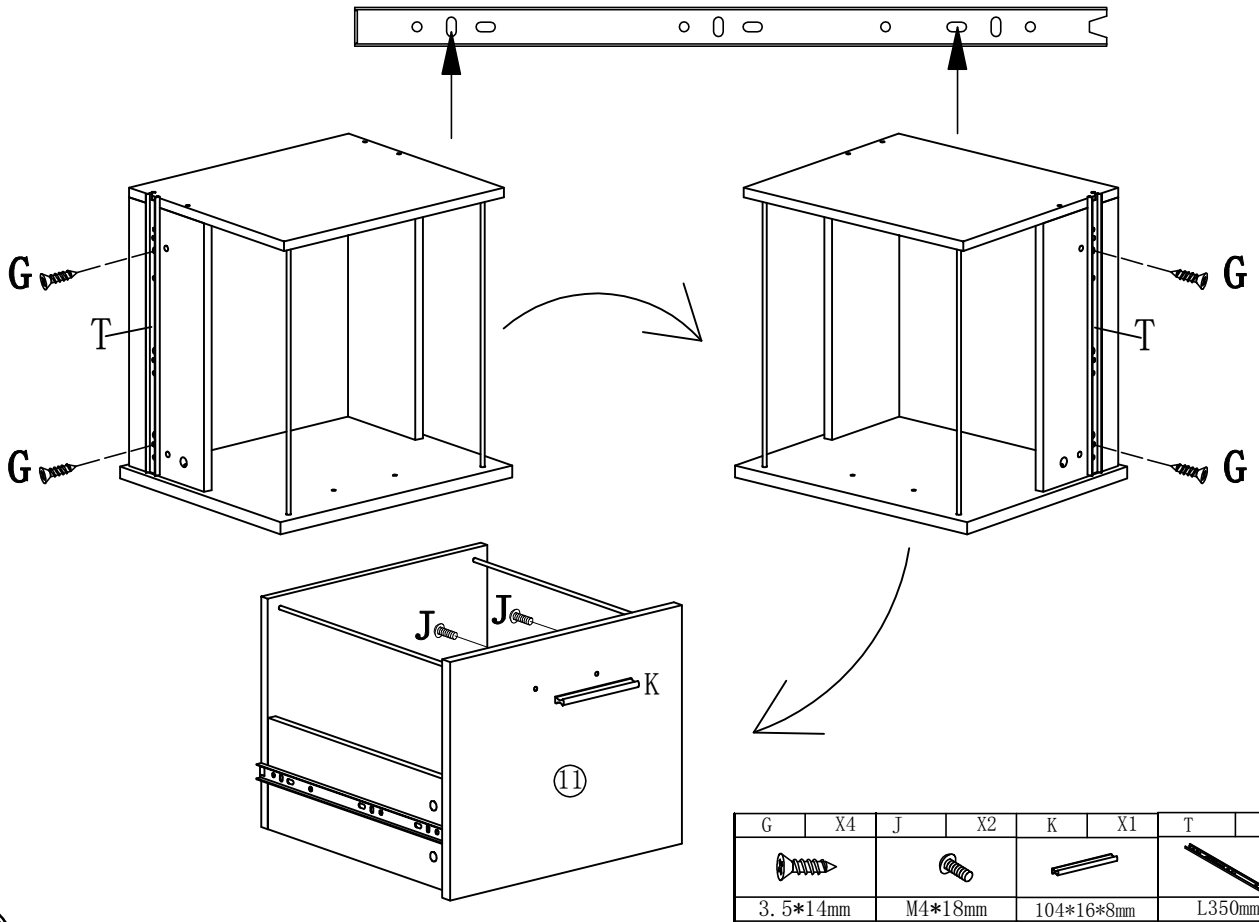

12

