

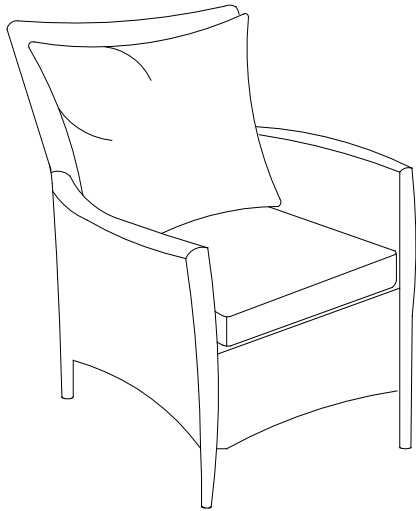

ARMCHAIR

Before you start, **here are** some helpful advice:

1. We suggest you spend a short time reading through this leaflet and then follow the simple step by step instructions.
2. Owing to the size and weight of the armchair, we recommend that it is assembled by two adults, on a carpeted or padded area, in the room that it is intended for. Approximate assembly time: 30 minutes.
3. Please do not use any tools other than those provided or recommended in these instructions.
4. Please do not throw away any of the packaging or instructions until you have checked all the components and hardware and the furniture is fully assembled.
5. Assemble all components loosely until advised to tighten. Depending on use, it may be necessary to tighten the components from time to time, so please save the tools that have been provided.
6. Please keep all pieces out of reach of children.

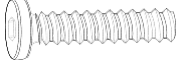

Hardware:

A		Long Bolt 1/4"x40mm	x 8
B		Flat Washer 1/4"	x 8
C		Allen Wrench 1/4"	x 1

Component:

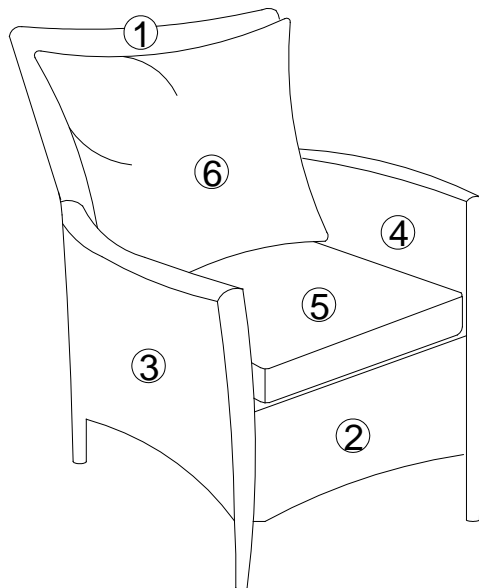

1	Chair Back	x1	2	Chair Seat	x1	3	Left Arm	x1	4	Right Arm	x1
5	EEI-1913 Seat Cushion (Packed separately)	x1	6	EEI-1913 Back Cushion (Packed separately)	x1						

ARMCHAIR

STEP 1:

Please put **Chair Back (1)** on a carpeted or padded area.

Place **Left Arm (3)** to **Chair Back (1)** as shown.

Insert 1 piece of **Bolt (A)** with 1 piece of **Flat Washer (B)** into the holes on **Chair Back (1)** through the holes on **Left Arm (3)**.

Use **Allen Wrench (C)** to tighten **Bolt (A)**. Do not fully tighten **Bolts (A)** at this step.

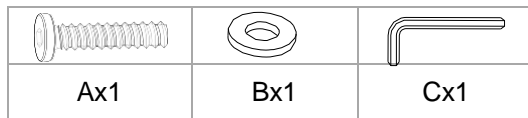
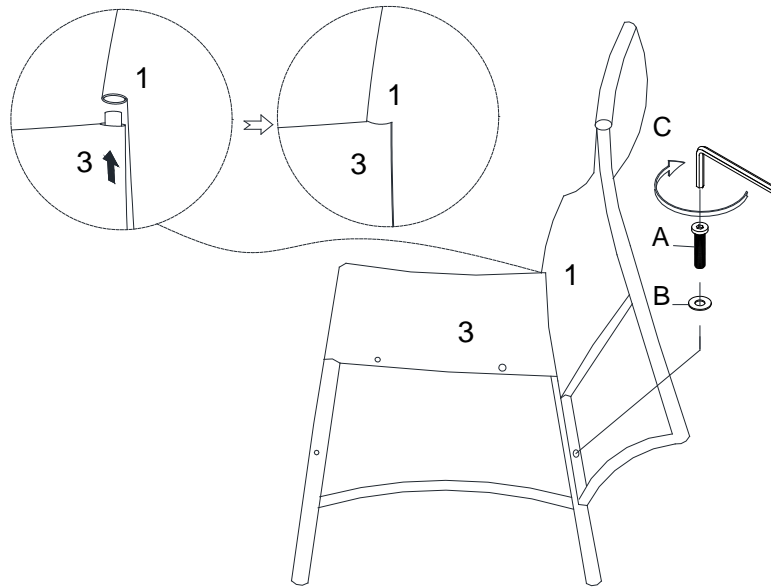

Hardware & Tool required

STEP 2:

Place **Right Arm (4)** to **Chair Back (1)** as shown.

Insert 1 piece of **Bolt (A)** with 1 piece of **Flat Washer (B)** into the holes on **Chair Back (1)** through the holes on **Right Arm (4)**.

Use **Allen Wrench (C)** to tighten **Bolts (A)**. Do not fully tighten **Bolts (A)** at this step.

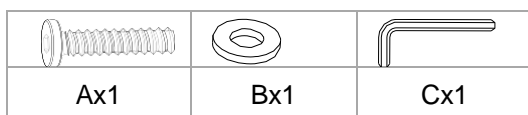
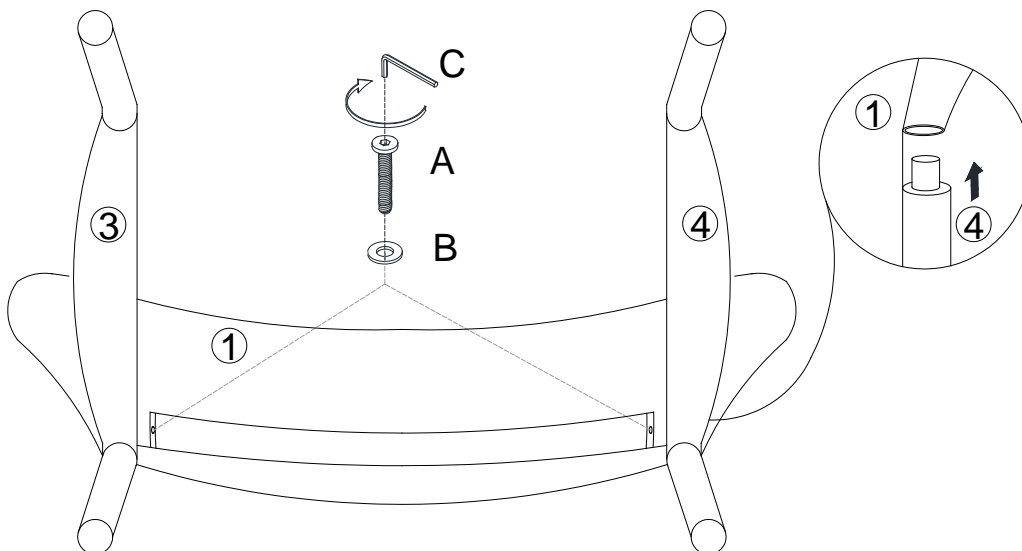

Hardware & Tool required

ARMCHAIR

STEP 3:

Insert **Chair Seat (2)** to the assembled **Chair Back (1)**, **Left Arm (3)** and **Right Arm (4)** as shown.

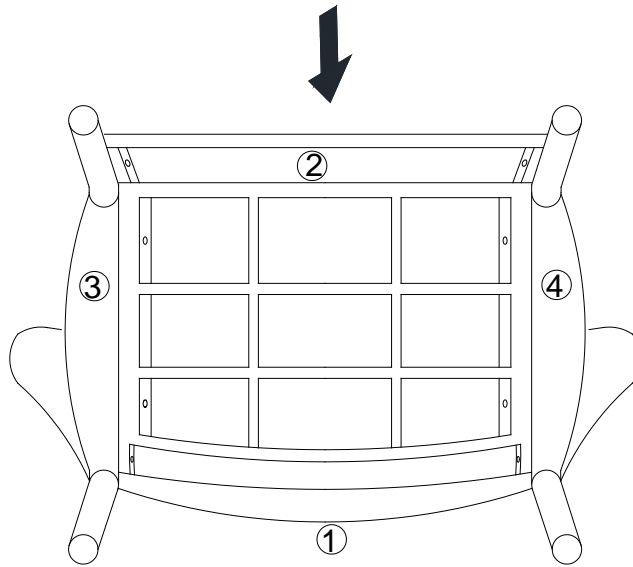



STEP 4:

Insert 6 pieces of **Bolt (A)** with 6 pieces of **Flat Washer (B)** into the holes on **Left Arm (3)** and **Right Arm (4)** through the holes on **Chair Back (1)** and **Chair Seat (2)**.

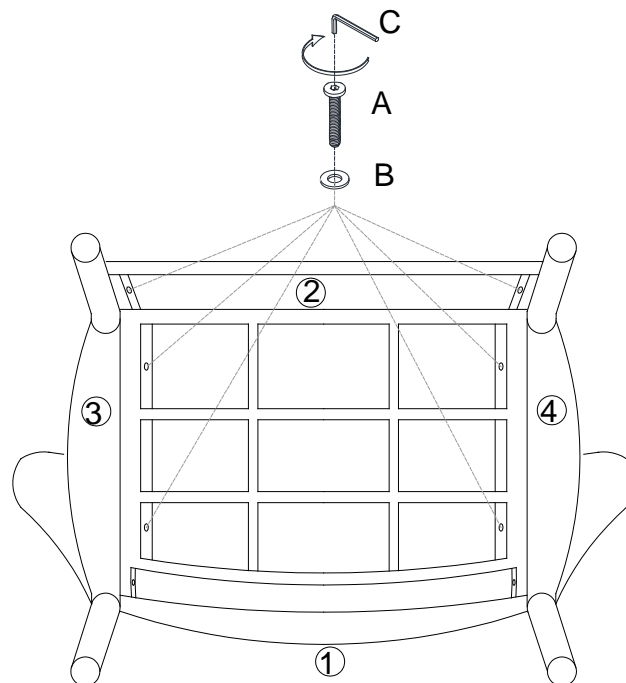
Use **Allen Wrench (C)** to tighten **Bolts (A)**. Do not fully tighten **Bolts (A)** at this step.



		
Ax6	Bx6	Cx1

Hardware & Tool required

ARMCHAIR

STEP 5:

Please carefully turn over the assembled chair.

Put a heavy object or seat one adult on top of the **Chair Seat (2)** to pressure the chair for leveling.

Use **Allen Wrench (C)** to tighten all **Bolts (A)** clockwise until secure.

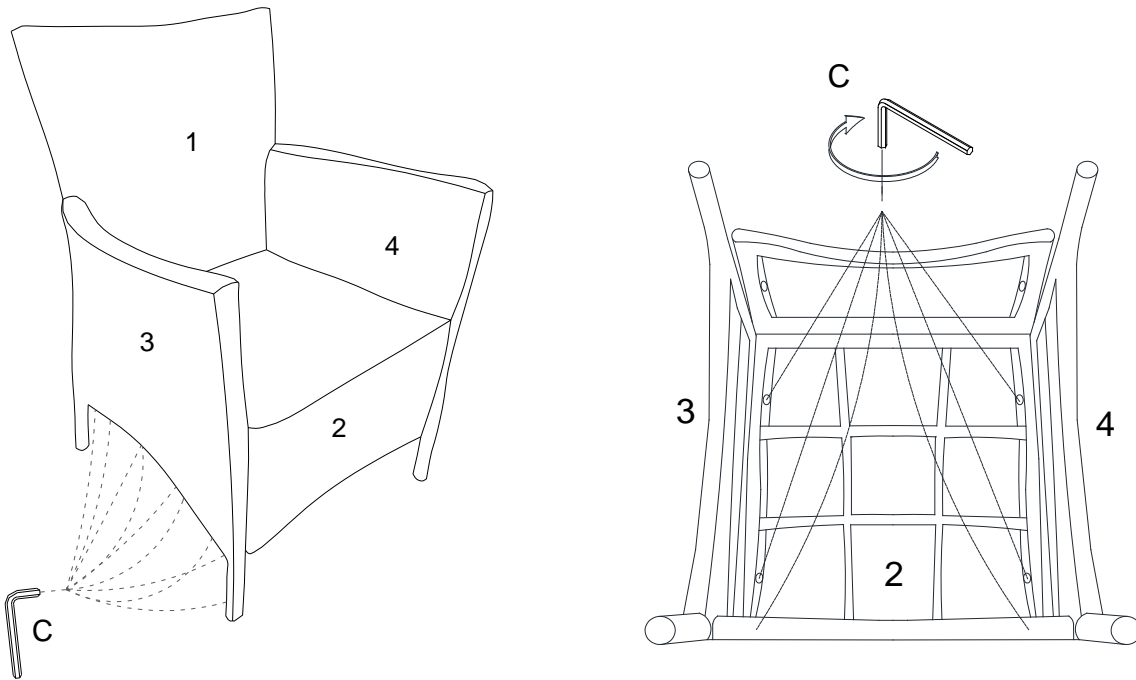

Assembly is complete. Your armchair is ready to be used now!

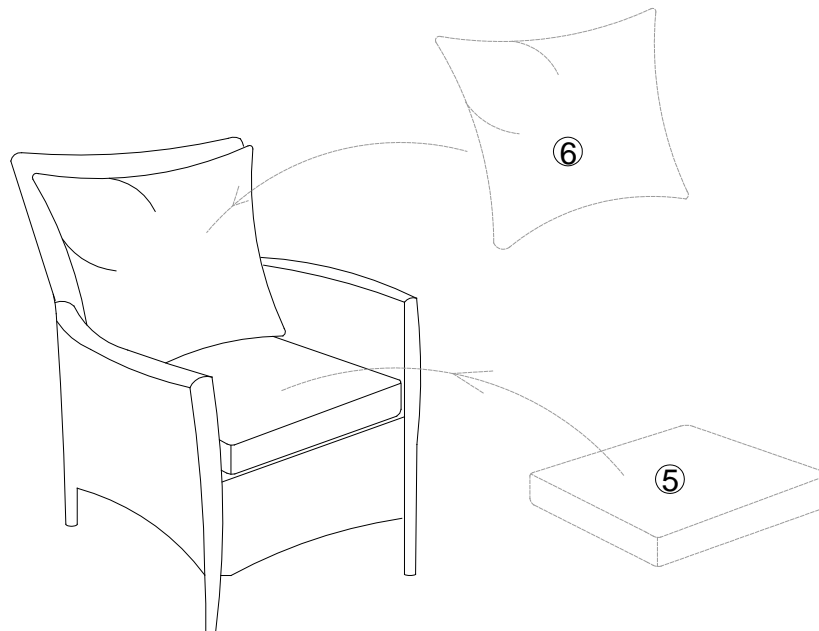

If you want a seat and back cushion for the armchair, you can purchase it from our store.

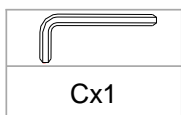

Hardware & Tool required