

HEADBOARD & FOOTBOARD

ASSEMBLY INSTRUCTIONS

Before assembling your headboard, please read through these instructions carefully and familiarize yourself with the different parts.



PARTS LIST

- ① LEFT POST 1 PC
- ② RIGHT POST 1 PC
- ③ HB TOP RAIL 1 PC
- ④ MID RAIL 1 PC
- ⑤ HB BOTTOM RAIL 1 PC
- ⑥ FOOTBOARD PANEL 1 PC
- ⑦ LEFT LEG 1 PC
- ⑧ RIGHT LEG 1 PC
- ⑨ FB TOP RAIL 1 PC
- ⑩ FB BOTTOM RAIL 1 PC

Instructions apply for bed sizes
FULL > QUEEN

HARDWARE

- ① JCB M6 X 110mm - 8 pcs
Spare - 1 pc
- ② Barrel Nut - 8 pcs
Spare - 1 pc
- ③ JCB M8 X 15mm (5/8") - 8 pcs
Assembly headboard and footboard to side rails
- ④ Wood Dowel - 16 pcs
Spare - 1 pc
- ⑤ Allen wrench - 1pc
Spare - 1pc
- ⑥ Allen wrench M6 - 1pc

NOTE: WE INCLUDE SPARE HARDWARE IN CASE DAMAGE OCCURS DURING ASSEMBLY.

Step 1

Insert all wooden dowels (D) into the locator holes on (3)(4)(5)(9) and(10) as shown below.

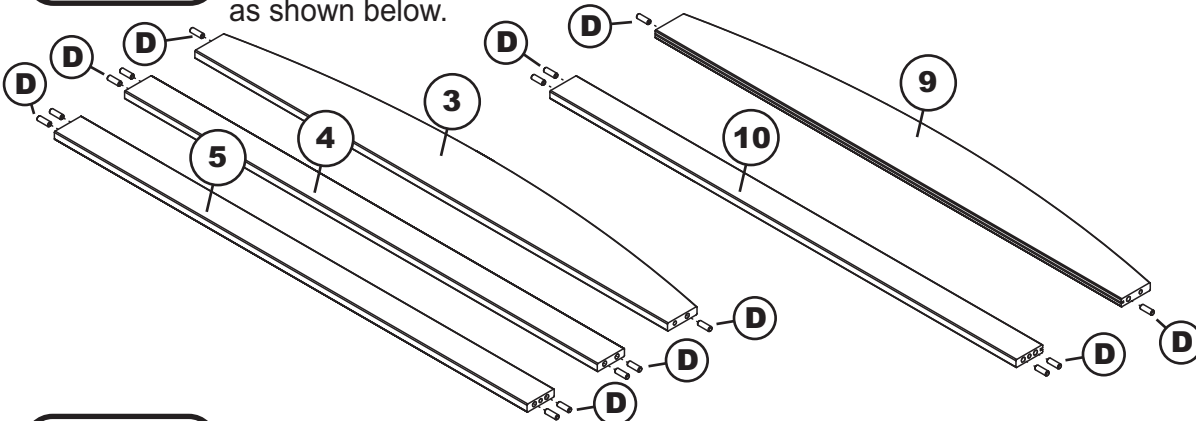

Adult assembly

④



Wood Dowel

Step 2

Lay the left and right post (1)(2) bracket face down on smooth surface. Connect HB top rail (3), mid rail (4) and HB bottom rail (5) as shown below, using JCB M6 X 110mm (A) and barrel nut (B). Tighten with the Allen wrench (E).

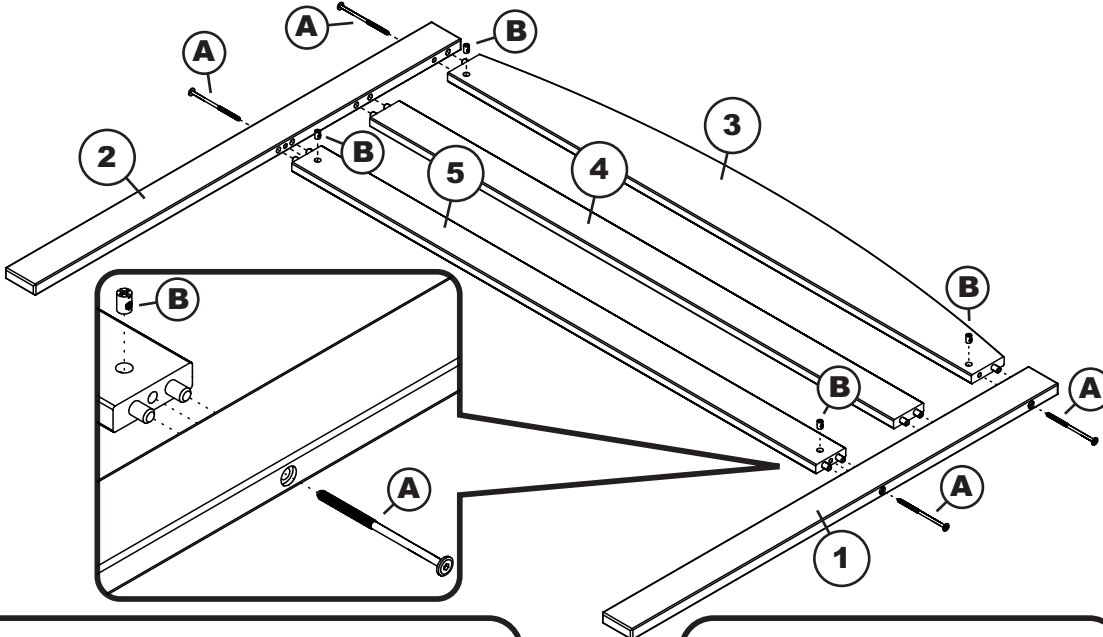

Adult assembly

①

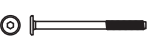

JCB M6 X 110mm

②



Barrel Nut

PO:

Step 3

Lay the left leg (7) bracket face up on smooth surface. Connect FB top rail (9) and FB bottom rail (10) as shown below, using JCB M6 X 110mm (A) and barrel nut (B). Tighten with the Allen wrench (E).

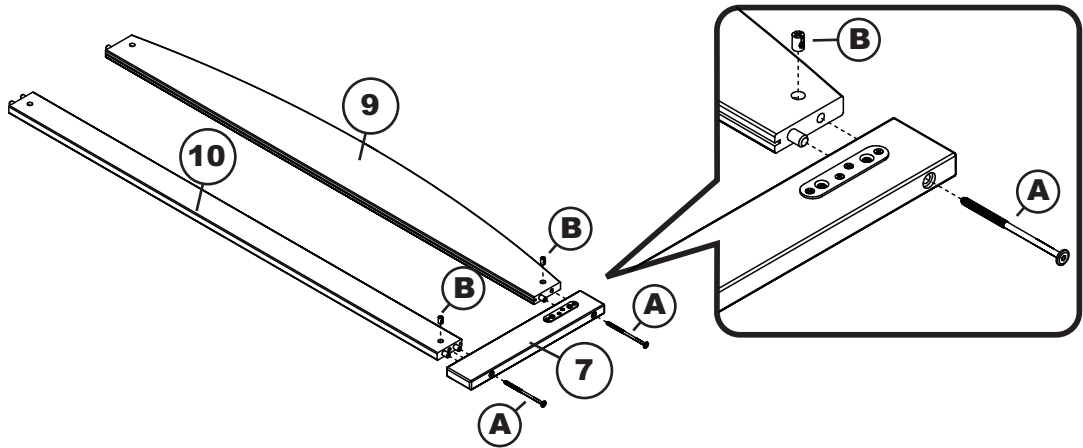
**Step 4**

Guide the footboard panel (6) in carefully so that it won't jump out of its grooves. Be sure it fits fully into the groove at the end (in the leg) before fitting the other leg.

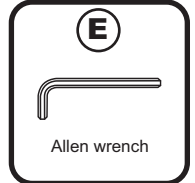
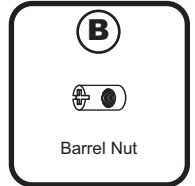
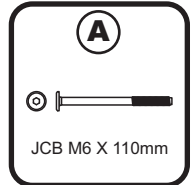
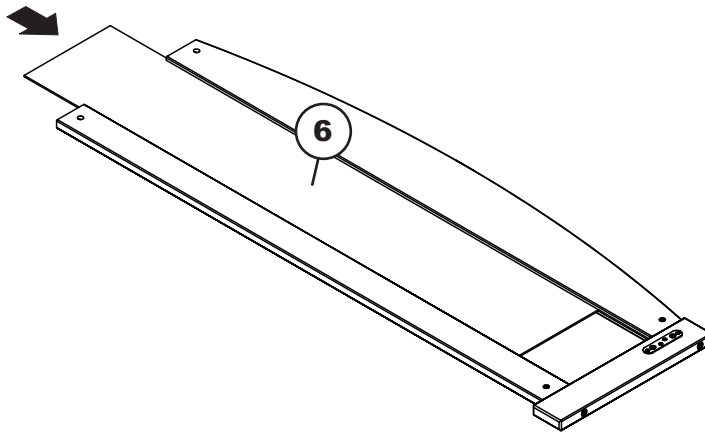
**Step 5**

Attach the right leg (8) to footboard assembly as shown below, using JCB M6 X 110mm (A) and barrel nut (B). Tighten with Allen wrench (E)

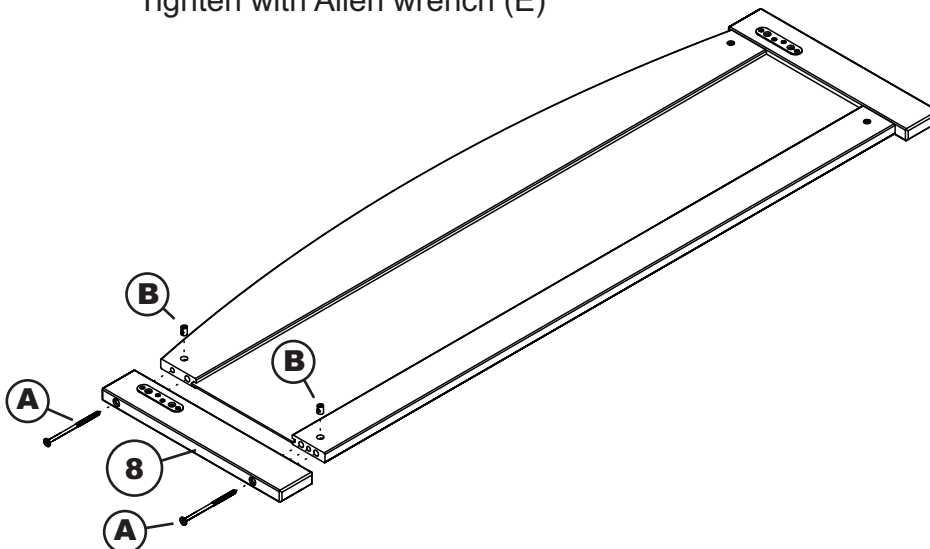

FULL > QUEEN

- 01 HARDWARE
 - 02 HEADBOARD
 - 03 FOOTBOARD
- BOX 1

- 01 HARDWARE
 - 04 SIDE RAILS
 - 05 SLAT KIT
- BOX 2

Step 1

Attach the side rails (04) to the headboard (02) and footboard (03) using JCB M8 X 15mm (C). Tighten with Allen wrench M6 (F).

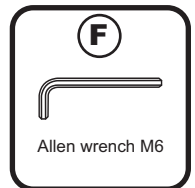
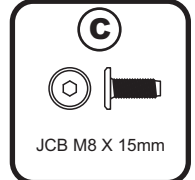
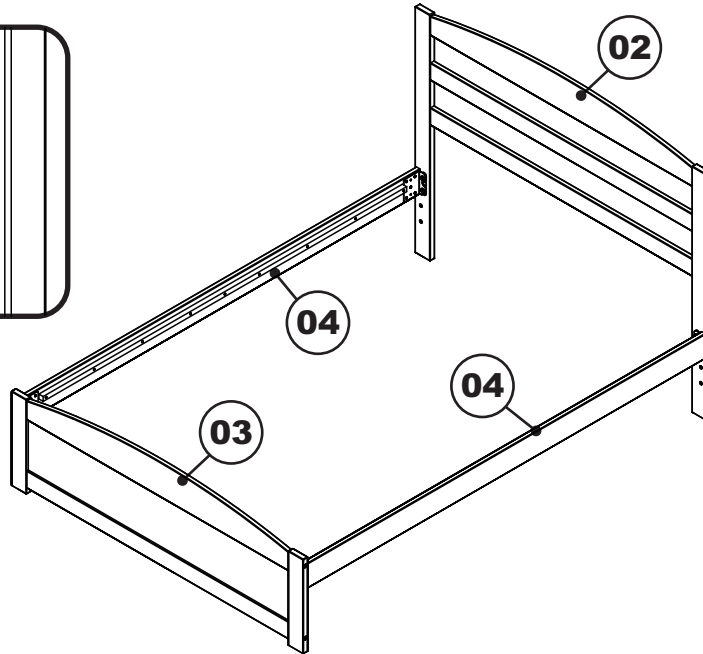
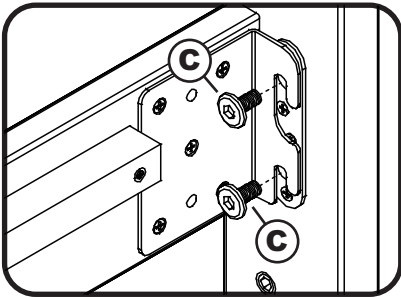

Step 2

Attach slat kit (05) onto the bed using wood screws. Tighten with Phillips head screw driver. (customer supplied) For assembly of slat kit, follow the assembly instructions included with bed frame.

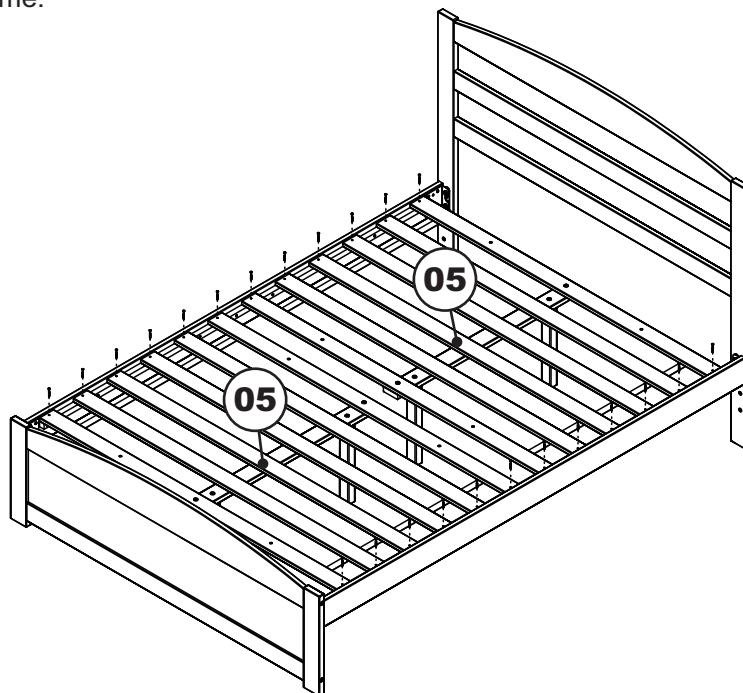

Congratulations!

Your bed is now ready for use.

We recommend that you periodically recheck that all screws are tight to ensure lasting safety.

BED FRAME

FULL ASSEMBLY INSTRUCTIONS

Before assembling your bed frame, please read through these instructions carefully and familiarize yourself with the different parts.



PARTS LIST

- ① SIDE RAIL 2 PCS
- ② SLAT KIT 2 SETS
- ③ SLAT SUPPORT 2 PCS
- ④ SLAT SUPPORT LEG 4 PCS

HARDWARE

- Ⓐ Wood screw (1 1/4") - 24 pcs Spare - 2 pcs
- Ⓑ JCB M6 X 25mm - 4 pcs
- Ⓒ Cap nut - 4 pcs
- Ⓓ Allen screw - 4 pcs
- Ⓔ Allen wrench - 1 pc

NOTE: WE INCLUDE SPARE HARDWARE IN CASE DAMAGE OCCURS DURING ASSEMBLY.

Step 1

Attach side rails (1) to the headboard and footboard. For assembly, follow the assembly instructions included with your headboard and footboard.

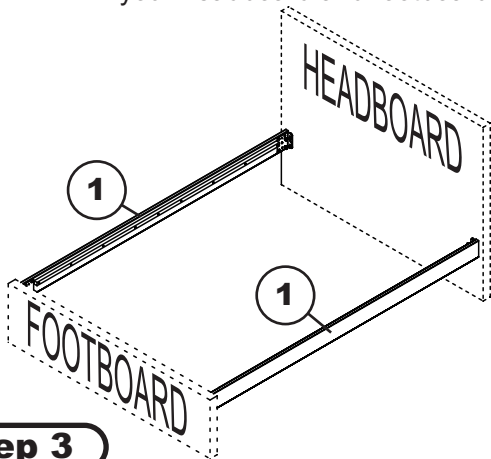

Step 2

Attach slat support legs (4) to slat support (3) as shown below using Allen screw (D) tighten with Allen wrench (E).

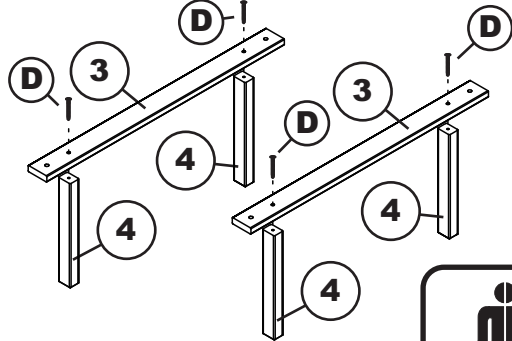

Step 3

Attach slat support (3) to the slat kit (2) as shown below using JCB M6 X 25mm (B) and cap nut (C). Tighten with Allen wrench (E).

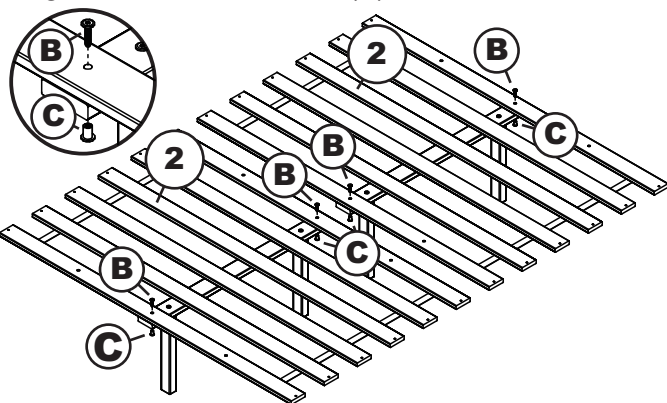

Step 4

Attach the slat kit (2) onto the bed using wood screws 1 1/4" (A). Tighten with Phillips head screw driver. (customer supplied)

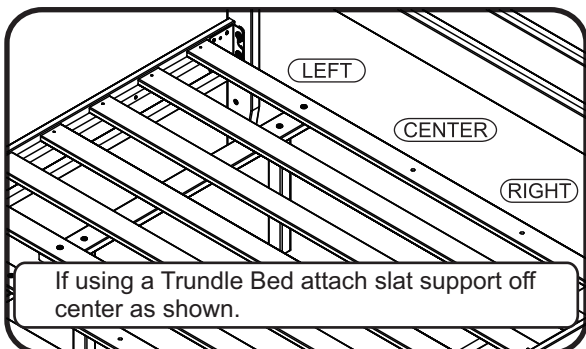
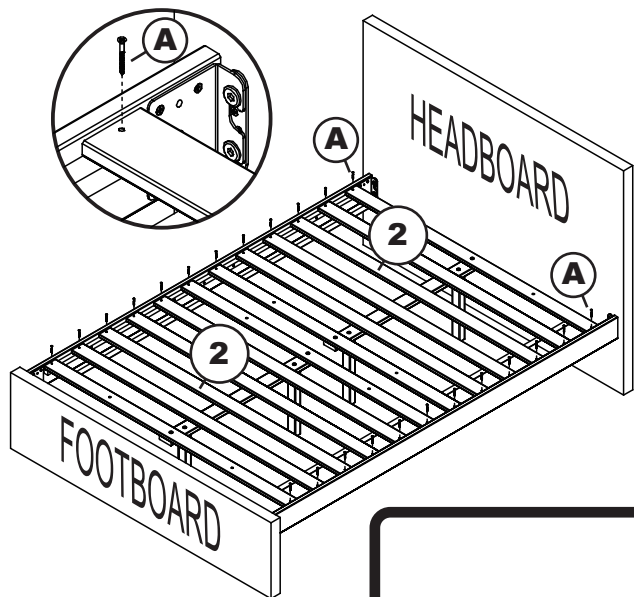

If using a Trundle Bed attach slat support off center as shown.

PO:

BED DRAWER

TWIN/FULL ASSEMBLY INSTRUCTIONS

Before assembling your bed drawer, please read through these instructions carefully, familiarize yourself with the different parts.

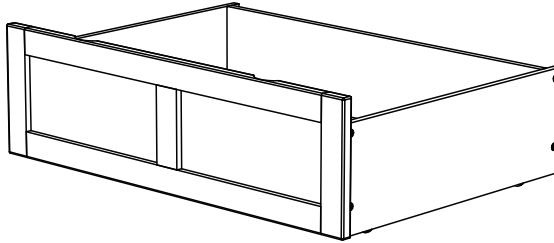
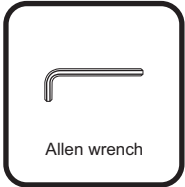

NOTE: WE INCLUDE SPARE HARDWARE IN CASE DAMAGE OCCURS DURING ASSEMBLY.

HARDWARE



(A) JCB M6 X 1" (25mm) - 16 pcs
Spare - 1 pc



(B) Wood Screw X 1 1/4" (32mm) - 4 pcs
Spare - 1 pc



(C) Allen wrench - 1 pc
Spare - 1 pc

PARTS LIST

- (01) HARDWARE 1 BOX**
- (02) DRAWER FACE 1 PC**
- (03) DRAWER SIDE 2 PCS**
- (04) DRAWER BACK 1 PC**
- (05) DRAWER BOTTOM 2 PCS**
- (06) DRAWER MIDDLE 1 PC**
- (07) DRAWER CENTER SUPPORT 1 PC**

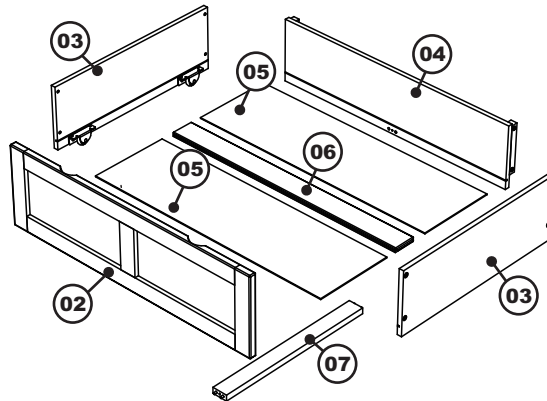

Step 1 Lay the drawer face (02) on smooth, flat surface so the drawer bottom (05) groove is facing upwards. Attach the drawer sides (03) to drawer face (02) using JCB M6 X 1" (A). Align groove inside drawer side with groove in drawer face. Tighten with Allen wrench (C).

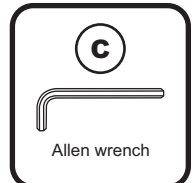
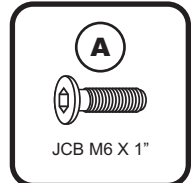
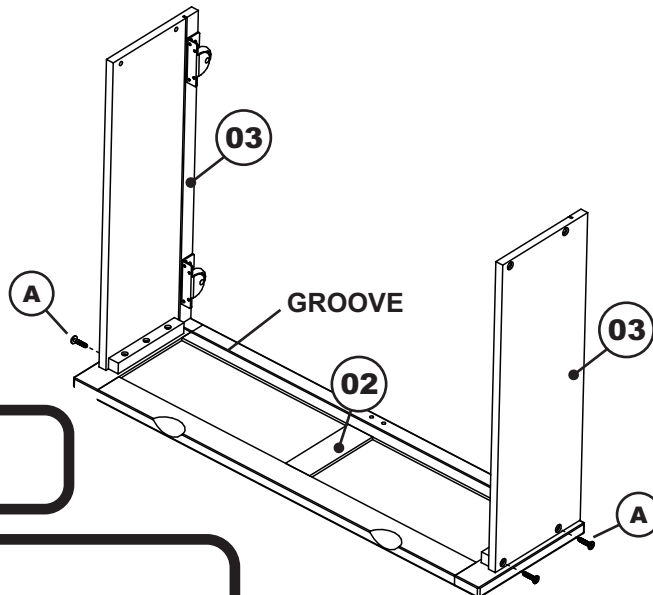

PO :

TWIN/FULL

Step 2

Guide the drawer bottoms (05) and drawer middle (06) in carefully so that they align inside grooves. Be sure it fits fully into the face and side groove before attaching the drawer back (04). Attach drawer center support (07) to bottom of drawer face using wood screw 1 1/4" (B). Tighten with Phillips head screw driver. (Customer supplied)

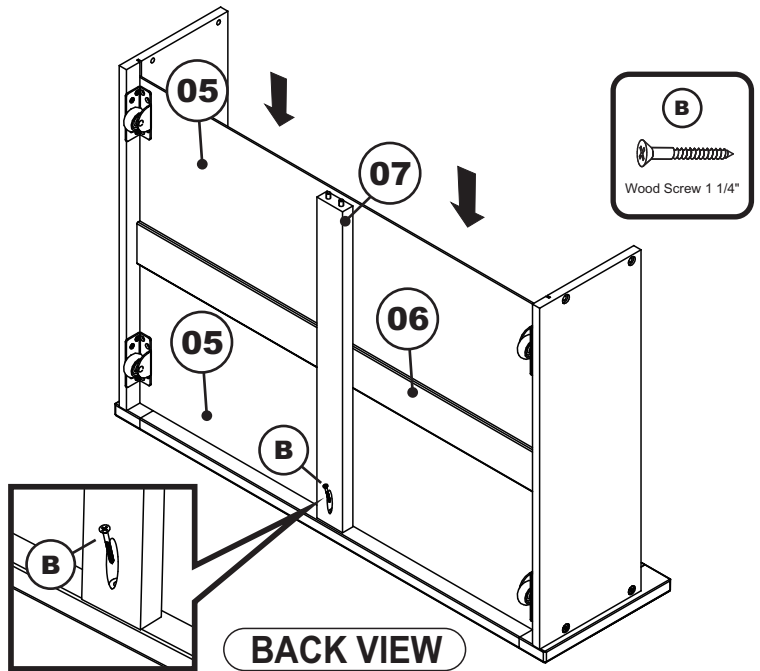
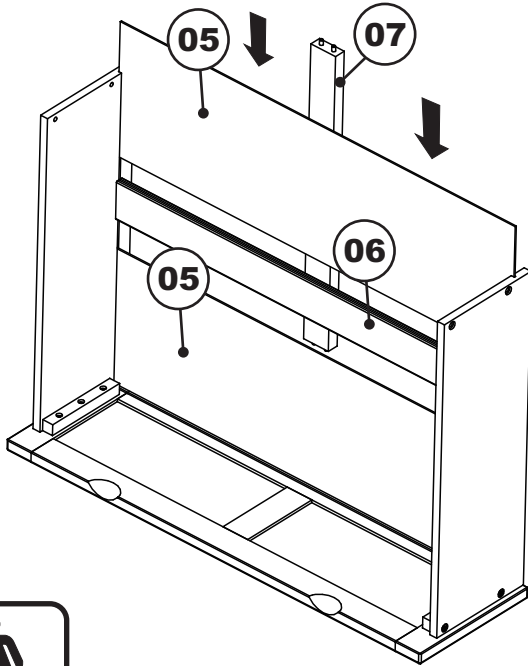

Adult assembly

Step 3

Attach drawer back (04) to bed drawer assembly as shown. Use JCB M6 X 1" (A). Tighten with Allen wrench (C). Use wood screws 1 1/4" (B) to finish attaching drawer center support (07) to drawer back (04). Tighten with Phillips head screw driver. (customer supplied)

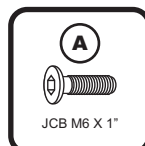
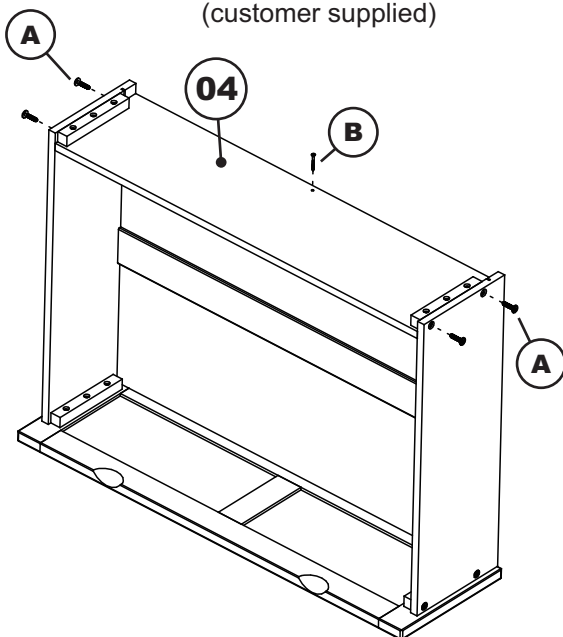

JCB M6 X 1"

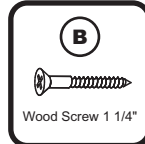

Wood Screw 1 1/4"

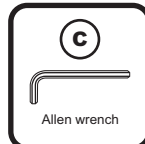

Allen wrench

Step 4

Lastly, insert bed drawer to the bed as shown below.

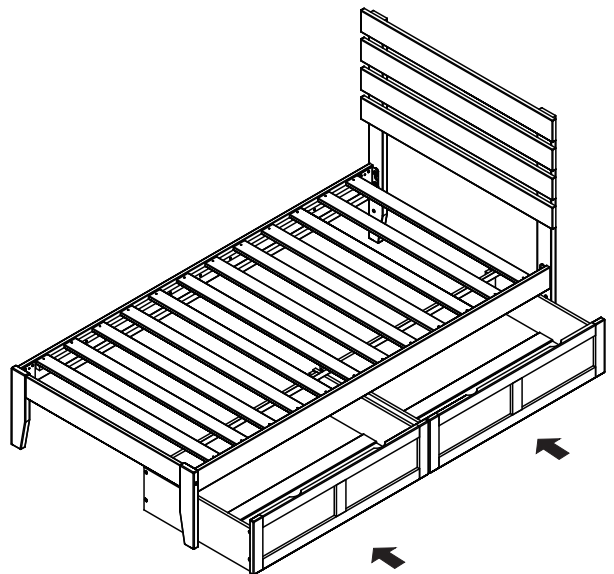

Adult assembly

Congratulations!

Your bed drawer is now ready for use. We recommend that you periodically recheck that all screws are tight to ensure lasting safety.