

Storage Cabinet with Sliding Door

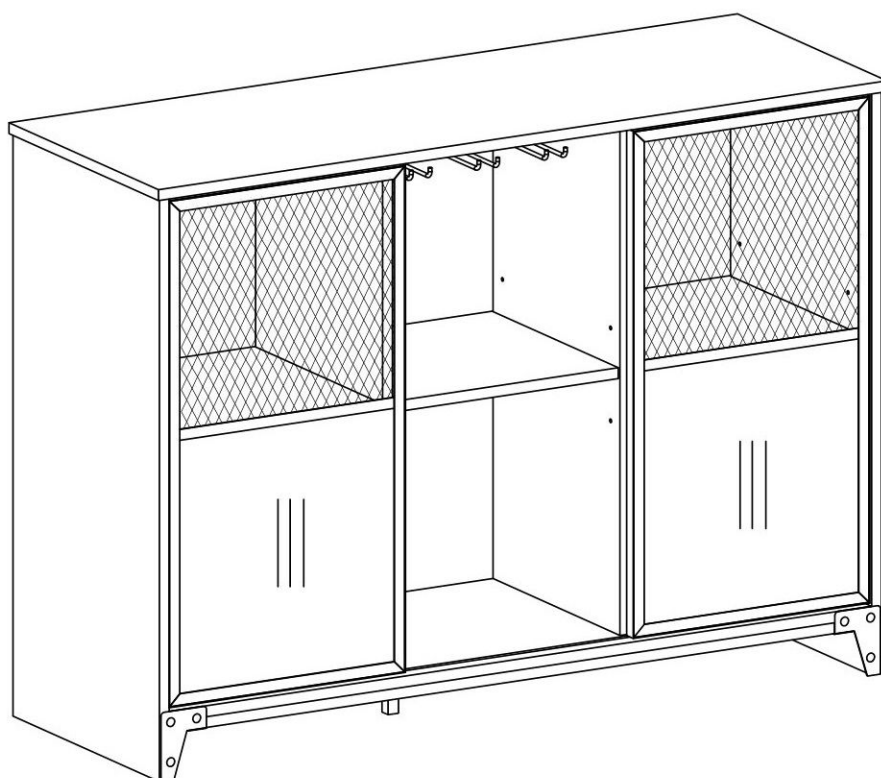

ASSEMBLY INSTRUCTION

Montageanleitung
Instructions De Montage
Istruzioni Per L'assemblaggio
Instrucciones De Montaje
組立説明書



HELPFUL HINTS

⚠ BEFORE YOU START

- Inspect product packaging to ensure the appearance is good.
- Read the assembly instruction carefully and follow it step by step.
- To avoid any scratching, putting a soft blanket on the floor is suggested.
- Identify, sort and count all the parts with tags.
- Find out installation position according to the drawing and install it in correct steps.



OTHER

- People needed for assembly: 1-2.
- Estimated assembly time: 0.5-1h.

⚠ CAUTION

- Be cautious when using a power drill or power screwdriver.
- Please be aware to slow down and stop when screw is nearly tight.
- Do Not use any harsh chemicals or abrasive cleaners for this item.
- Push, pull or drag this item carefully.

ASTUCES UTILES

⚠ AVANT DE COMMENCER

- Inspectez l'emballage du produit pour vous assurer que l'apparence est bonne.
- Lisez attentivement les instructions de montage et suivez-les étape par étape.
- Pour éviter toute rayure, posez une couverture douce sur le sol est suggéré.
- Identifiez, trie et comptez toutes les pièces avec des étiquettes.
- Trouver la position d'installation selon le dessin et l'installer dans les étapes correctes.



AUTRE

- Personnes nécessaires pour l'assemblage : 1-2.
- Temps de montage estimé : 0.5-1 h.

⚠ AVERTIR

- Soyez prudent lorsque vous utilisez une perceuse électrique ou un tournevis électrique.
- Veuillez être conscient de ralentir et d'arrêter lorsque la vis est presque serrée.
- N'utilisez pas de produits chimiques corrosifs ou de nettoyeurs abrasifs pour cet article.
- Poussez, tirez ou tirez cet article avec précaution.

CONSEJOS ÚTILES

⚠ ANTES DE EMPEZAR

- Inspeccione el paquete del producto para asegurarse de que la apariencia es buena.
- Lea atentamente las instrucciones de montaje y sigalas paso a paso.
- Para evitar rayas, se sugiere poner una manta suave en el suelo.
- Identifique, clasifique y enumere todas las piezas con etiquetas.
- Averigüe la posición de instalación según el dibujo e instálela en los pasos correctos.



OTROS

- Personas necesarias para el montaje: 1-2.
- Tiempo de montaje estimado: 0.5-1 h.

⚠ PRECAUCIÓN

- Tenga cuidado al utilizar un taladro eléctrico o un destornillador eléctrico.
- Tenga en cuenta que debe hacerlo más despacio y detenerse cuando el tornillo esté casi apretado.
- No utilice productos químicos agresivos ni limpiadores abrasivos para este artículo.
- Empuje, tire o arrastre este elemento con cuidado.

NÜTZLICHE HINWEISE

⚠ BEVOR SIE BEGINNEN

- Überprüfen Sie die Produktverpackung auf Schäden.
- Lesen Sie sich die Montageanleitung sorgfältig durch und befolgen Sie sie Schritt für Schritt.
- Um etwaiges Zerkratzen zu vermeiden, wird das Auslegen einer weichen Decke auf dem Boden empfohlen.
- Identifizieren, sortieren und zählen Sie alle Teile mit Tags nach.
- Identifizieren Sie die Montageposition gemäß der Zeichnung und bauen Sie das Regal den richtigen Schritten entsprechend auf.



SONSTIGES

- Für den Zusammenbau erforderliche Anzahl an Menschen: 1-2.
- Ungefähre Montagedauer: 0.5-1 h.

⚠ VORSICHT

- Seien Sie bei der Verwendung einer Bohrmaschine oder eines Akkuschraubers vorsichtig.
- Bitte vergessen Sie nicht darauf, langsamer zu werden und zu stoppen, sobald die Schraube fast festgezogen ist.
- Verwenden Sie keinerlei aggressive Chemikalien oder scheuernden Reinigungsmittel für dieses Produkt.
- Schieben oder ziehen Sie dieses Produkt vorsichtig.

SUGGERIMENTI UTILI

⚠ PRIMA DI INIZIARE

- Controllare la confezione del prodotto per assicurarsi che sia in buono stato.
- Leggere con attenzione le istruzioni per l'assemblaggio e seguirle passo dopo passo.
- Per evitare graffi al pavimento, suggeriamo di stendervi una coperta morbida.
- Identificare, suddividere e contare tutte le parti con etichetta.
- Trovare la posizione adatta per il montaggio in base al disegno e montare lo scaffale seguendo correttamente i vari passaggi.



ALTRO

- Persone necessarie per l'assemblaggio: 1-2.
- Tempo di assemblaggio stimato: 0.5-1 ora.

⚠ ATTENZIONE

- Prestare molta attenzione quando si utilizza un trapano elettrico o un cacciavite elettrico.
- Rallentare con accortezza e fermarsi quando una vite è già sufficientemente serrata.
- Non utilizzare prodotti chimici aggressivi o detergenti abrasivi su questo articolo.
- Spingere, tirare o trascinare questo articolo con cautela.

役に立つヒント

⚠ 組立の場所を確保し、順番通りに組み立てる

- 組立場所 (充分広くて平たい場 v 所) を確保してください。
- 床や壁、商品を傷つけないように、商品の下に厚めの布や段ボールなどを敷いてください。
- 組立の順番を守らないと、組立できなくなったり、商品を傷つけたりします。



その他

- 組み立てに必要な人: 1-2.
- 組立時間: 約0.5~1時間。

⚠ 部品を確認する

- ネジ類などの部品番号、形状を説明書の部品一覧で確認してください。
- 部品をなくさないように纏めて置いてください。
- 部品を取り出すときに使う分だけ取り出してください。

UNIT:INCH/CM

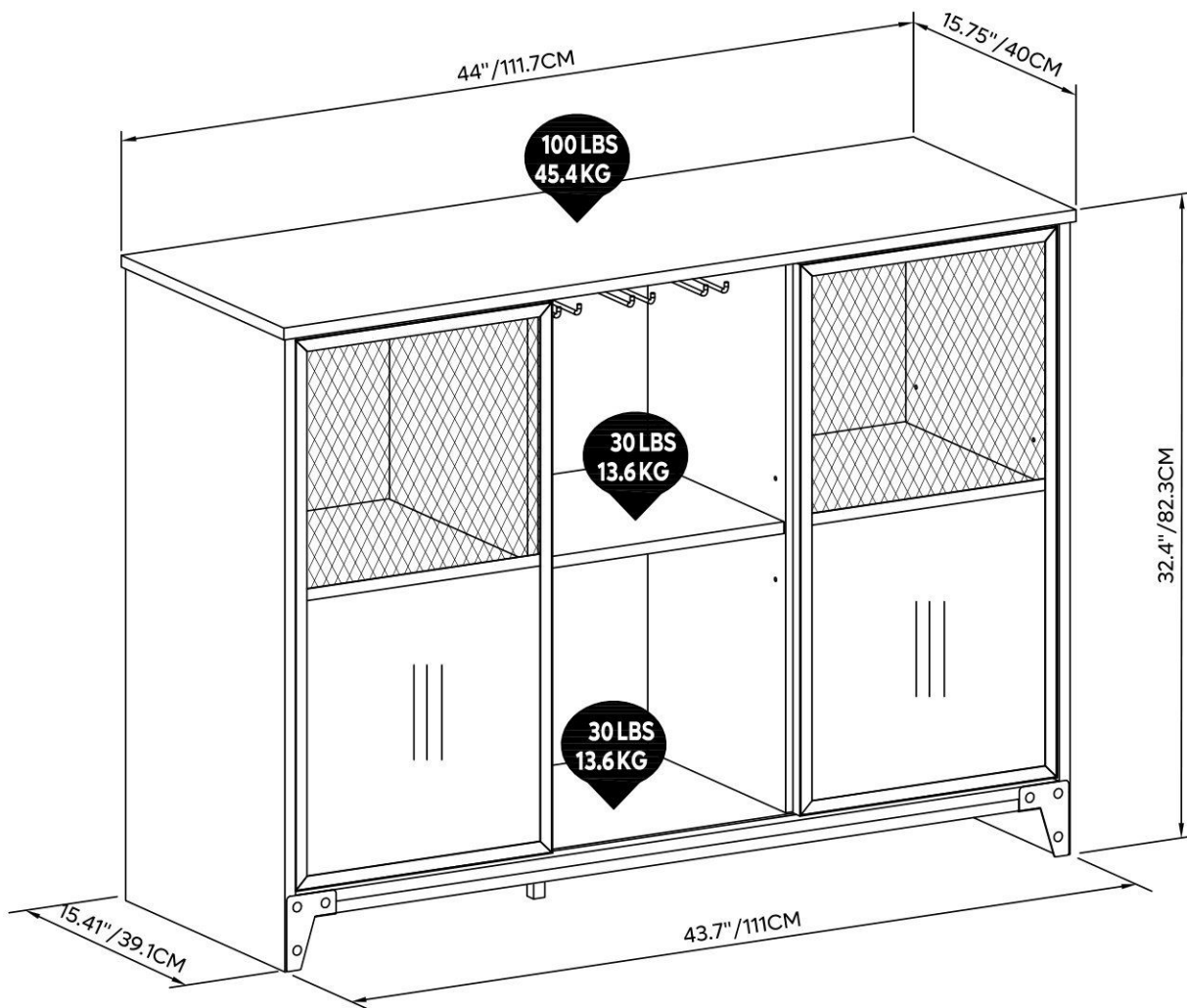

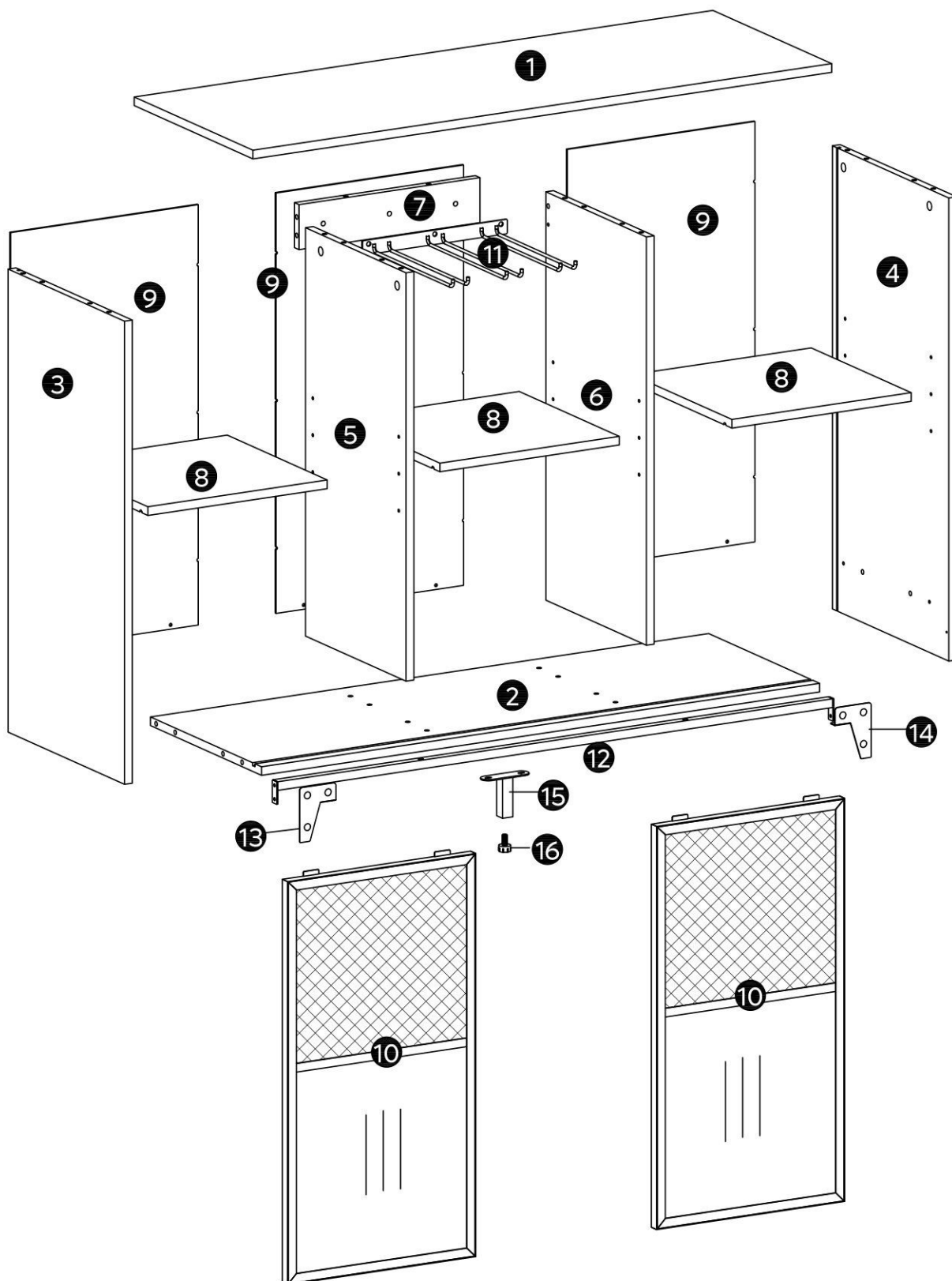

PART LIST

STÜCKLISTE
LISTE DES PIÈCES
ELENCO DEI PEZZI

LISTA DE PIEZAS
部品の確認

1

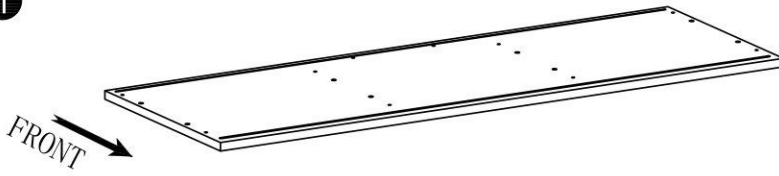

X1

2

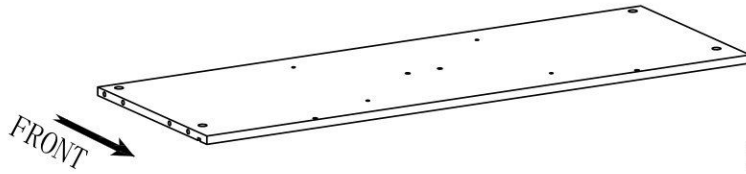

X1

3

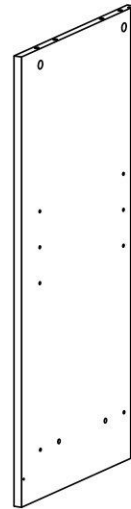

X1

4

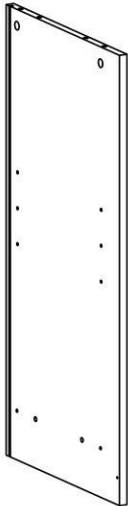

X1

5

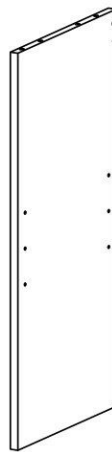

X1

6

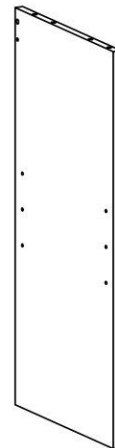

X1

7

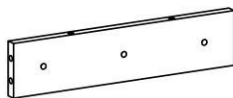

X1

8



X3

9

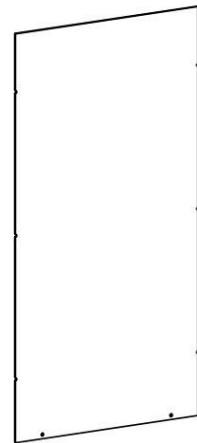

X3

PART LIST

STÜCKLISTE
LISTE DES PIÈCES
ELENCO DEI PEZZI

LISTA DE PIEZAS
部品の確認

10

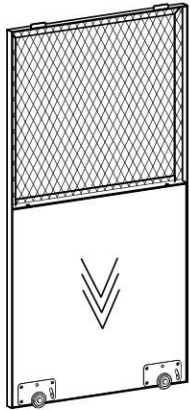

X2

11

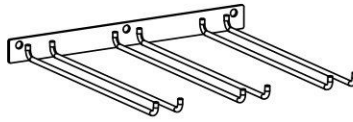

X1

12

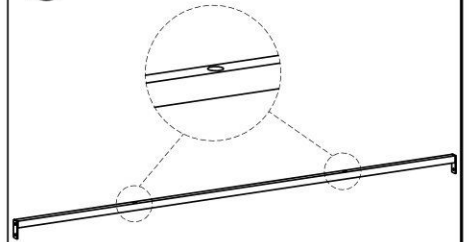

X1

13

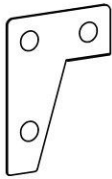

X1

14

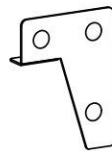

X1

15



X1

16











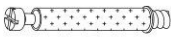

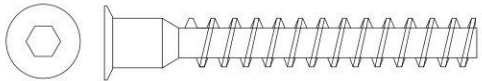
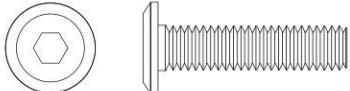

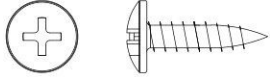

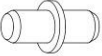

X1

ACCESSORY LIST

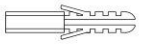
ZUBEHÖRLISTE
LISTE DES ACCESSOIRES
ELENCO DEGLI ACCESSORI

LISTA DE ACCESORIOS
付属品部品の確認

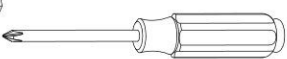
A	ST6x35mm	16+1	
B	Ø15mm	16+1	
C	Ø8x30mm	18+1	
D	ST7x50mm	4+1	
E	M6x25mm	2	
F	M6x12mm	7+1	
G	ST4x16mm	14+1	
H	ST4x12mm	2	
I	ST3x14mm	2	
J		2	
K	Ø5x14mm	12+1	
L	Ø22mm	8	
M	Ø8mm	8+1	
N		2	<div style="display: flex; justify-content: space-between;"> <div style="text-align: center;">  N1 x 1 ST4x38mm </div> <div style="text-align: center;">  N2 x 1 </div> </div> <div style="display: flex; justify-content: space-between; margin-top: 10px;"> <div style="text-align: center;">  N3 x 2 </div> <div style="text-align: center;">  N4 x 1 </div> </div>
		1	 M4 

Detailed Installation for Accessory A B

Installation détaillée pour l'accessoire A B
Detaillierte Installation des Zubehörs A B
Installazione dettagliata per l'accessorio A B
Instalación detallada del accesorio A B
カムロック取り付け方

1

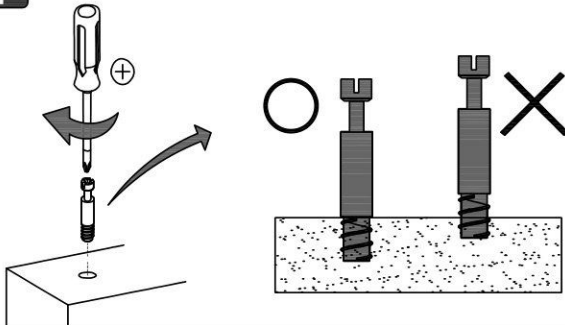

Screw cam dowel on the panel.
Vissez la goupille de came au panneau.
Nockendübel auf die Platte schrauben.
Avvitare il tassello a camme sul pannello.
tornillo de pasador de leva en el panel.

Place another panel via the dowel.
Placez un autre panneau par le goujon.
Setzen Sie eine weitere Platte über den Dübel ein.
Posizionare un altro pannello tramite il tassello.
Coloque otro panel a través del pasador.
カムロックネジをカムロック穴に差し込む。

2

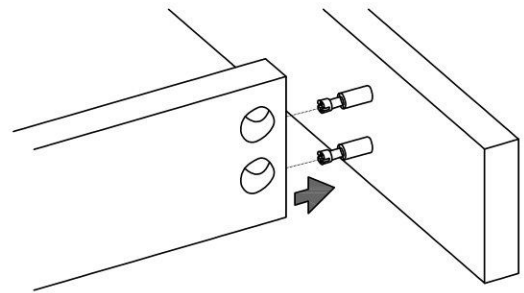

3

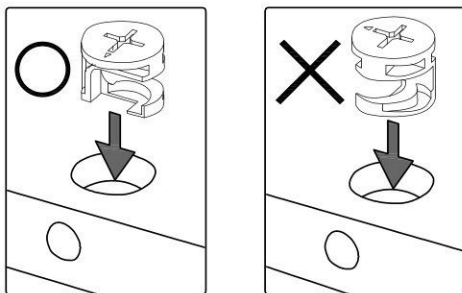

Pay attention to the direction of cam lock when putting it into hole.

Faites attention à la direction du verrou à came en entrant dans le trou.

Achten Sie auf die Richtung des Nockenschlosses, wenn Sie es in das Loch stecken.

Fare attenzione alla direzione della serratura a camme quando lo si inserisce nel foro.

Preste atención a la dirección de la leva de fijación al insertarla en el orificio.

カムロックネジの方向にカムロックの穴の穴の向きを合わせ取り付ける。

Tighten up cam lock clockwise until it stops.
Serrez le verrou à came dans le sens des aiguilles d'une montre jusqu'à ce qu'il s'arrête.
Ziehen Sie die Nockenverriegelung im Uhrzeigersinn bis zum Anschlag an.
Stringere la serratura a camme in senso orario fino all'arresto.
Apriete la leva de fijación en sentido horario hasta el tope.
カムロックをドライバーで締め固定する。

4

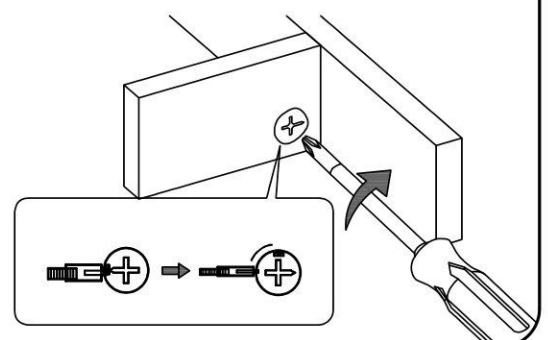

1

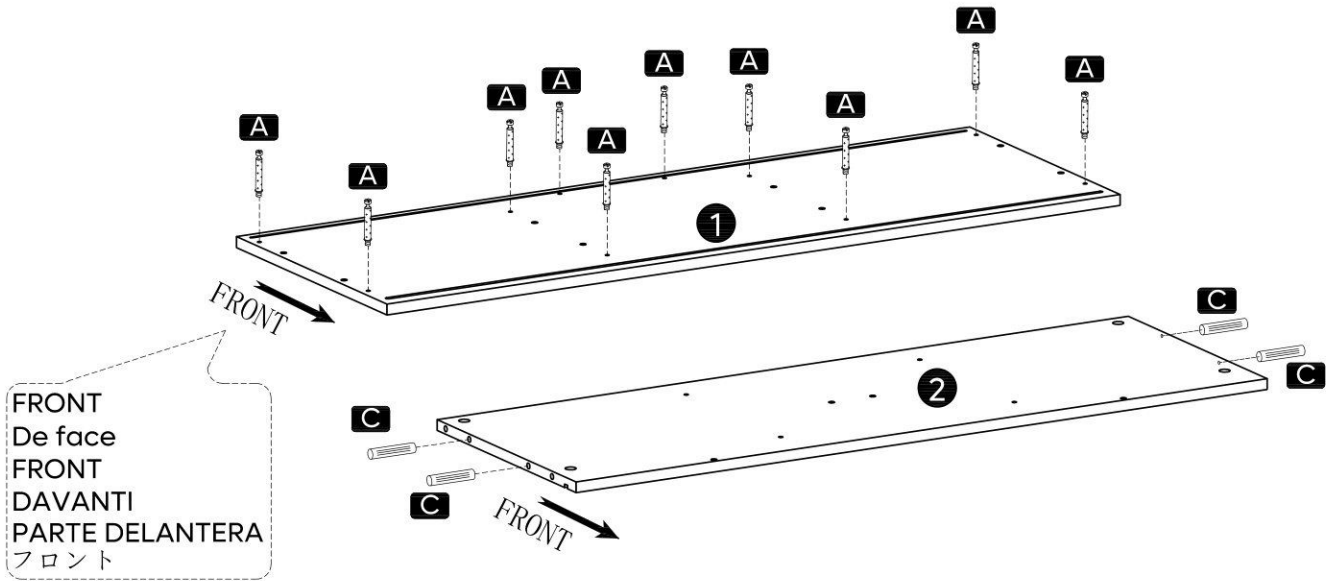

FRONT
De face
FRONT
DAVANTI
PARTE DELANTERA
フロント

x 10

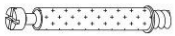

A ST6x35mm

x 4

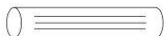

C Ø8x30mm

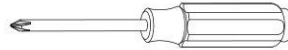

2

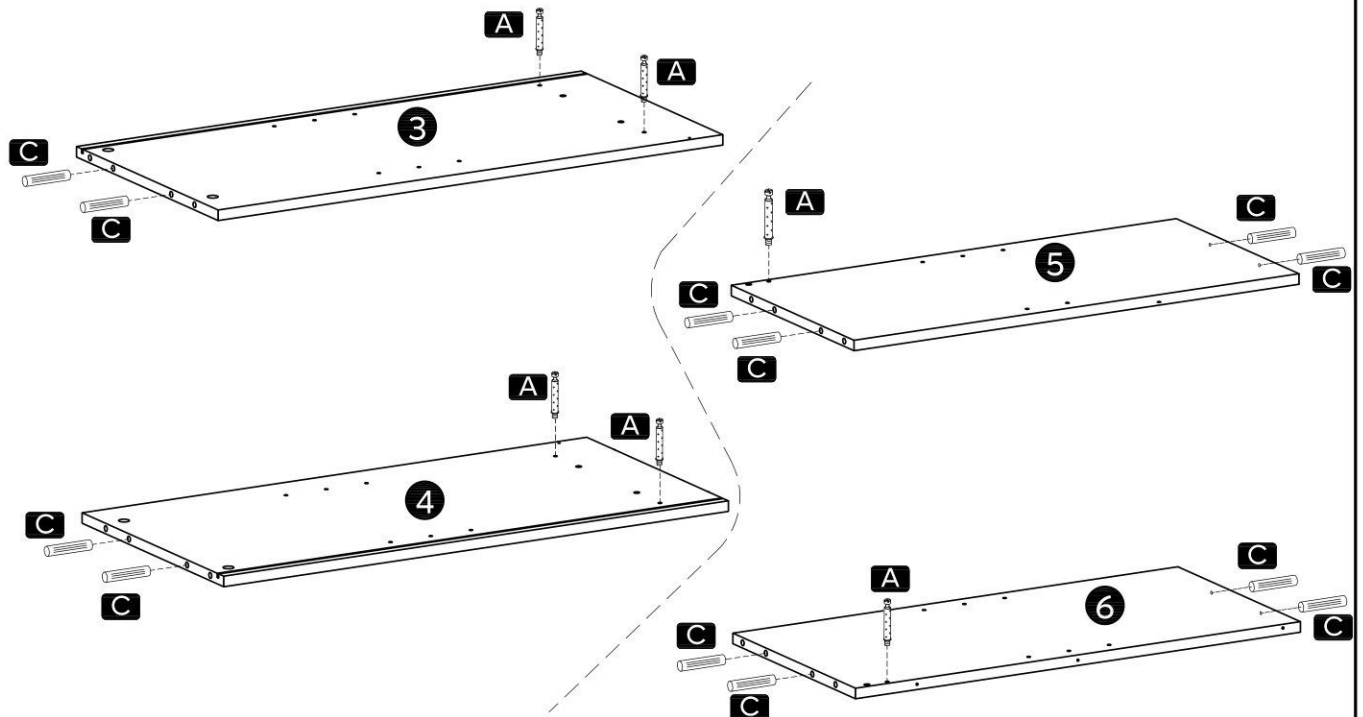

x 6

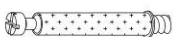

A ST6x35mm

x 12

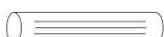

C Ø8x30mm

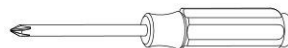

3

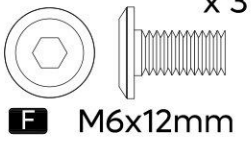
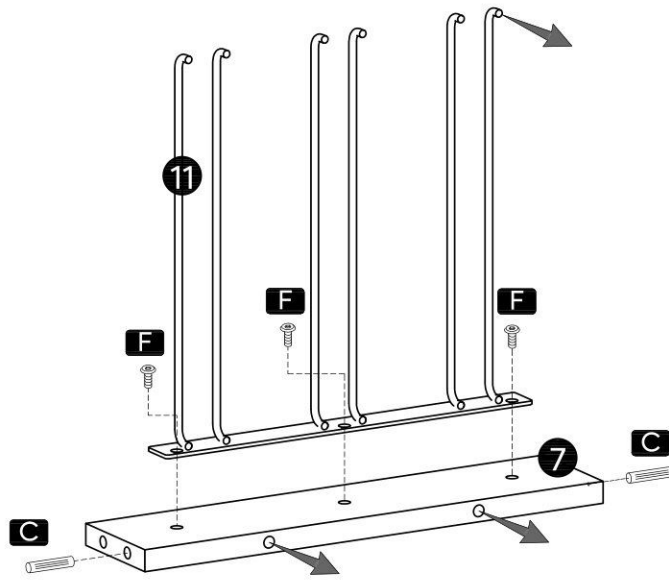

x 3



x 2

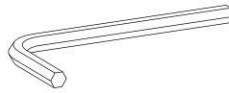

4

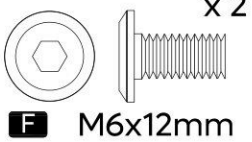
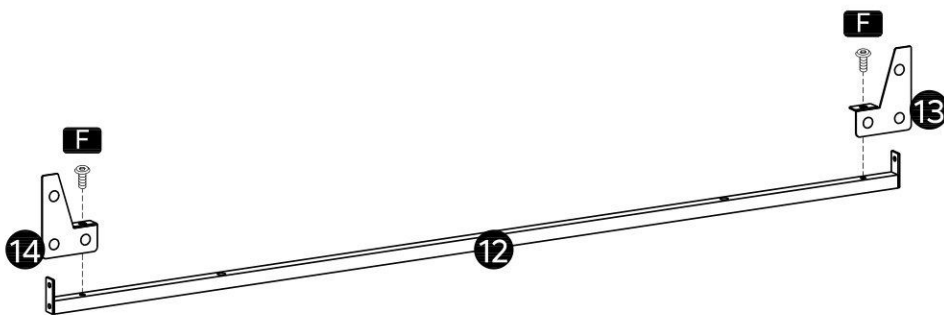

x 2

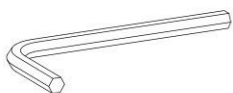

5

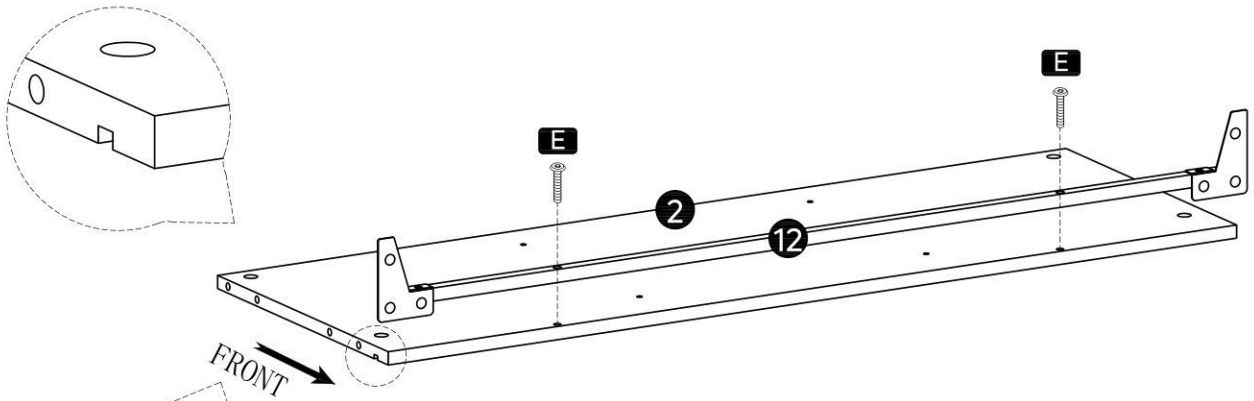

FRONT
De face
FRONT
D'AVANTI
PARTE DELANTERA
フロント

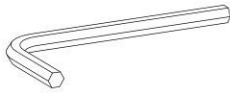
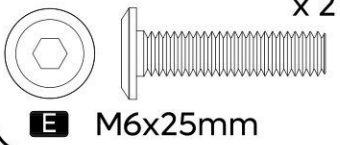

6

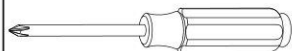
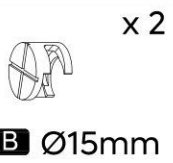
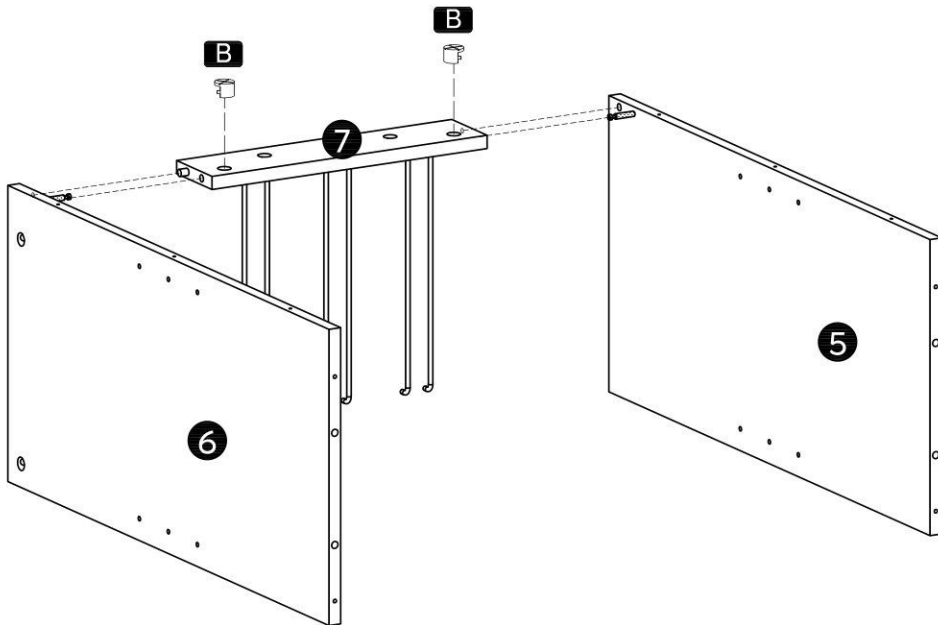

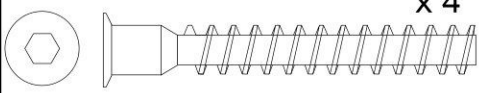
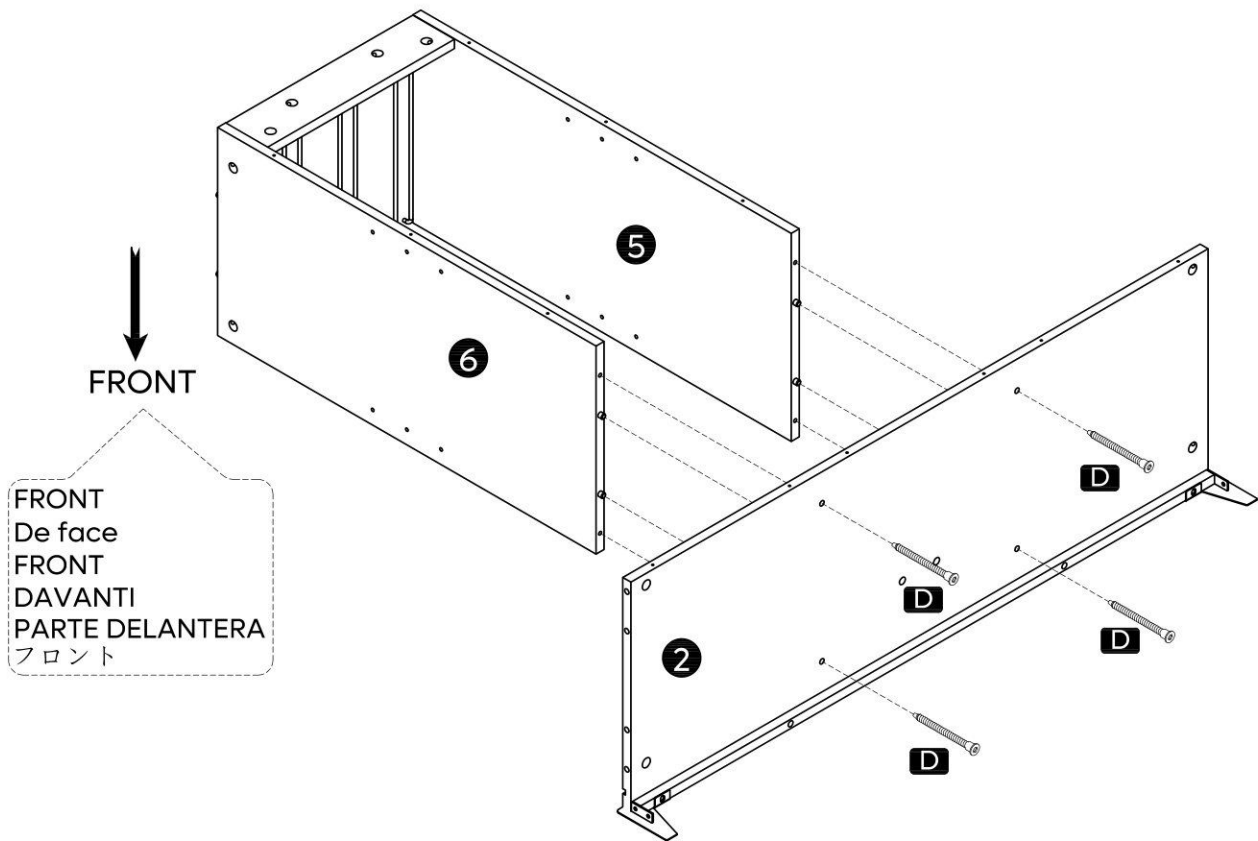

D ST7x50mm

8

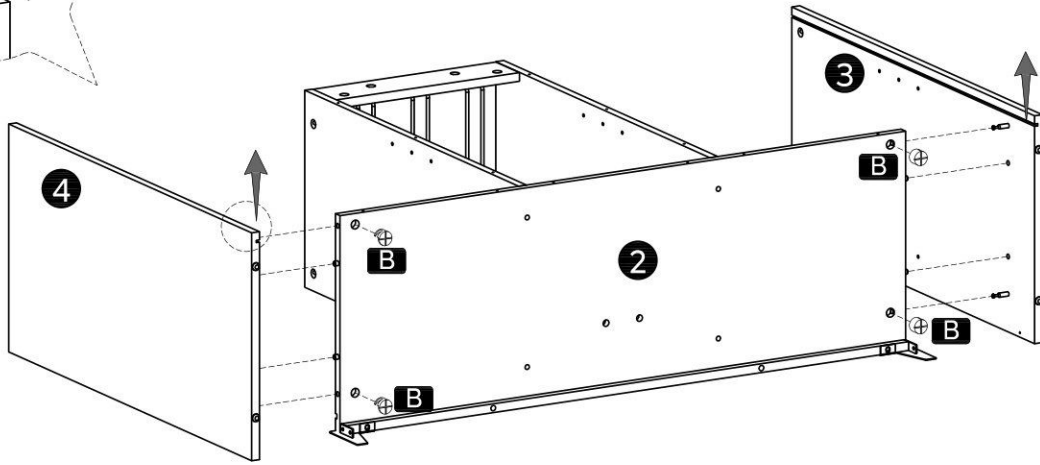
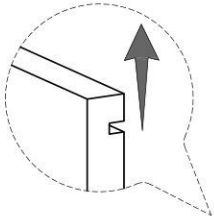

x 4

B Ø15mm

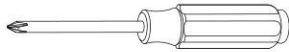

9

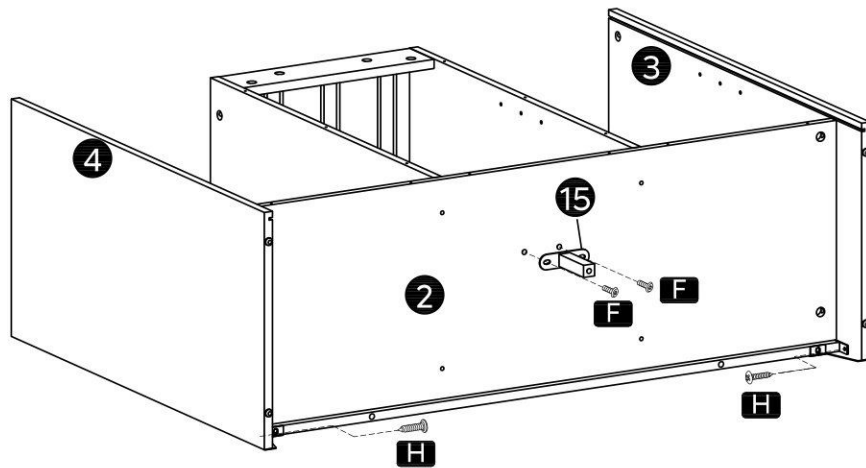

x2

F M6x12mm



x 2

H ST4x12mm

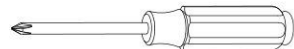
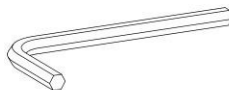

10

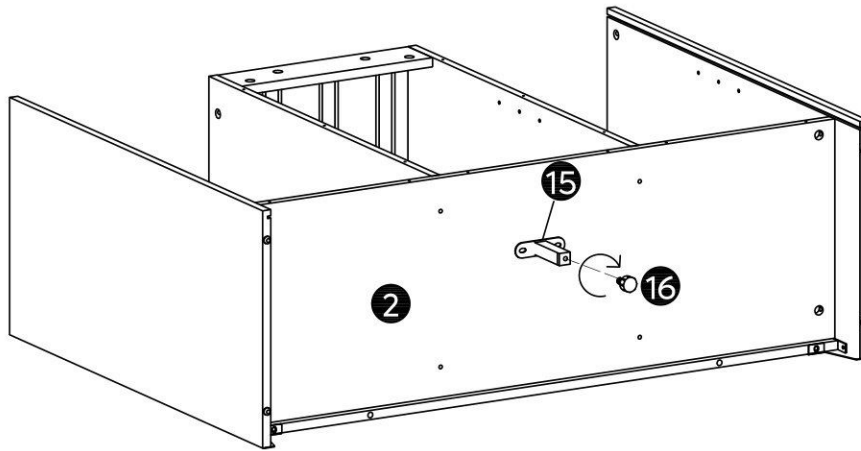

11

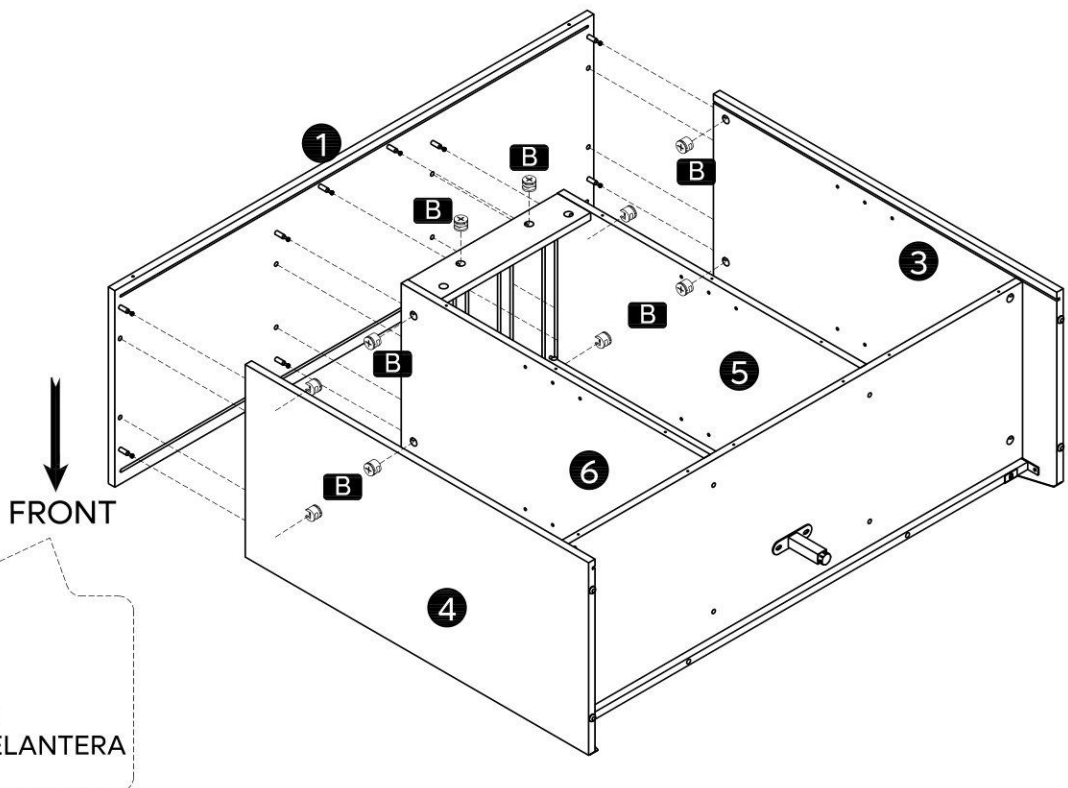

FRONT
De face
FRONT
DAVANTI
PARTE DELANTERA
フロント

x 10



B Ø15mm

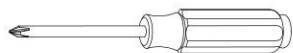

12

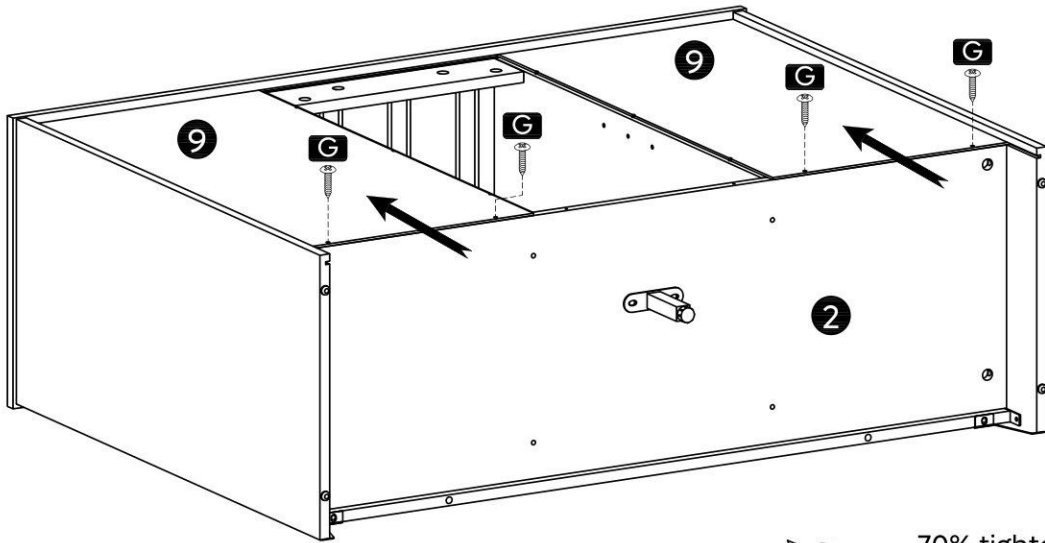

70% tighten
 70 % serré
 70% festziehen
 Serraggio al 70%
 70 % reforzado
 70%締め付け

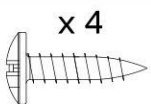

x 4

G ST4x16mm

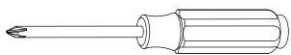

13

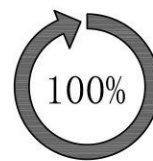
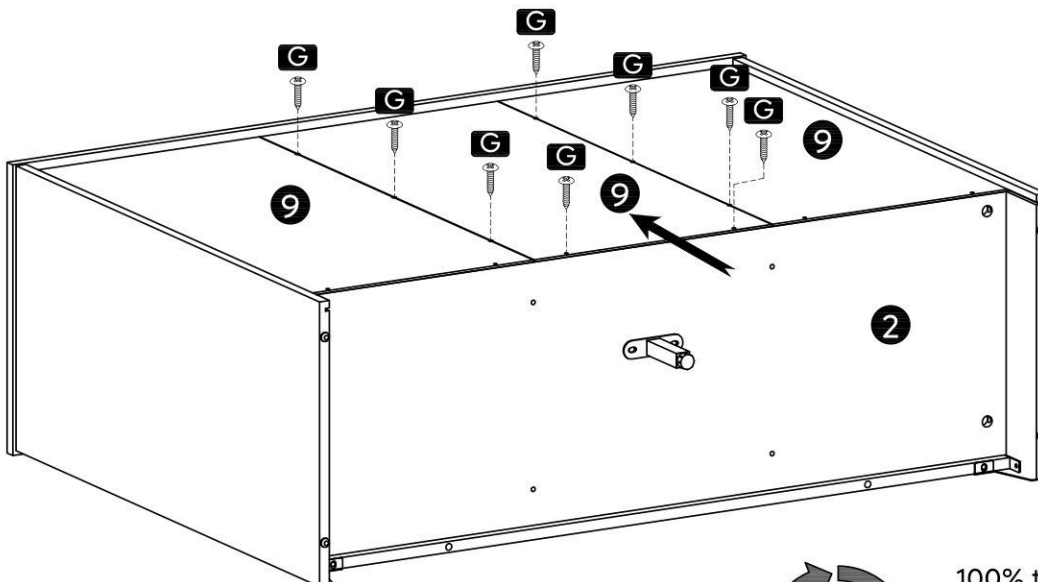

100% tighten
 100 % serré
 100% festziehen
 Serraggio al 100%
 100 % reforzado
 100%締め付け

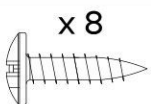

x 8

G ST4x16mm

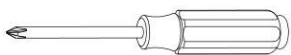

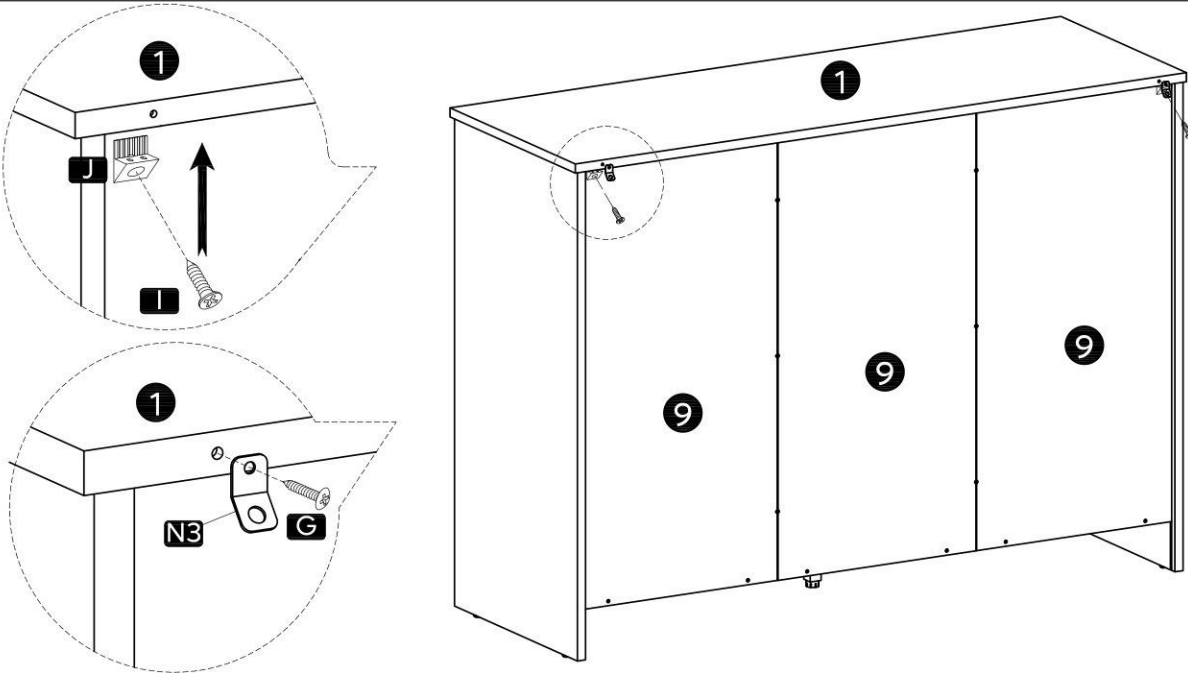

14

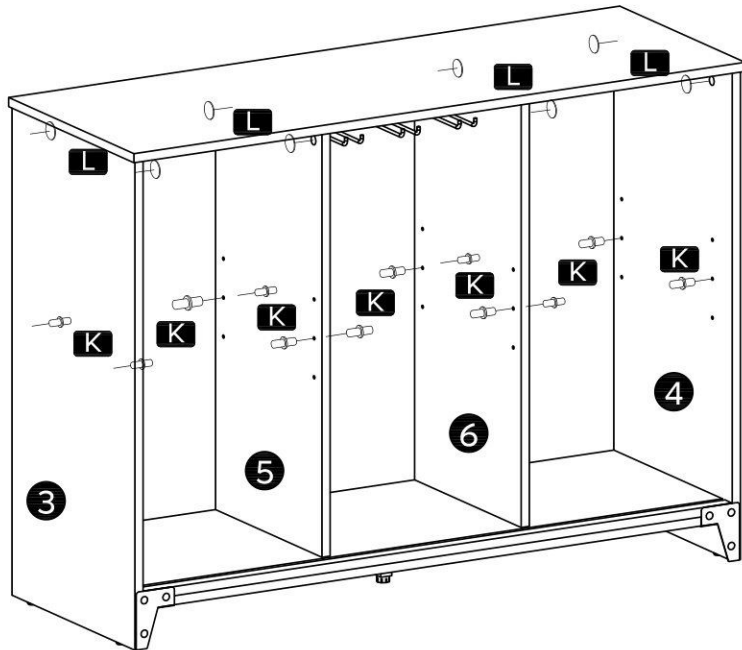

x 2	x 2	x 2	x 2	
				
G ST4x16mm	I ST3x14mm	J ST3x14mm	N3	

15

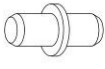

x 12	x 8
	
K Ø5x14mm	L Ø22mm

16

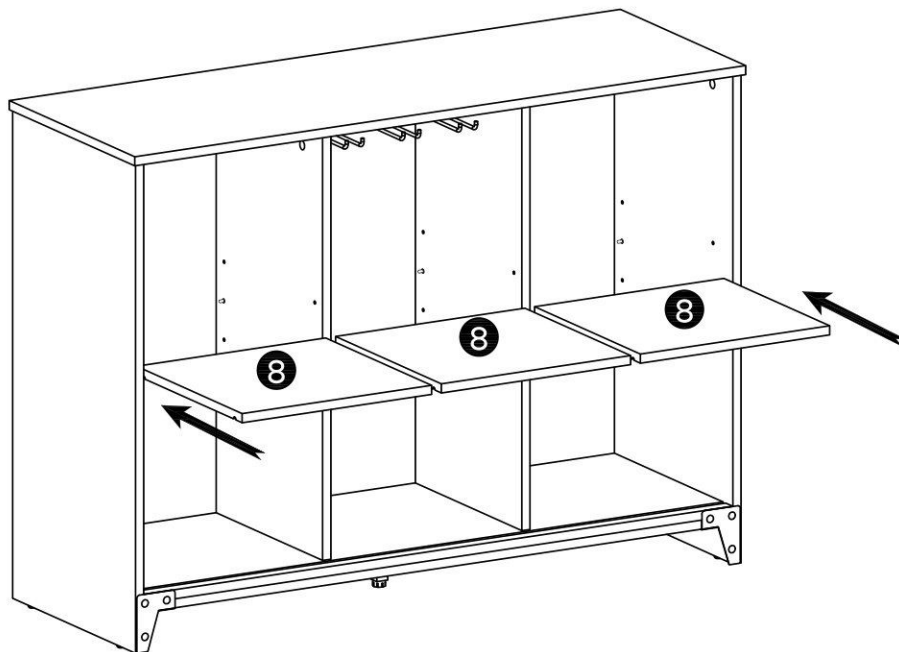

17

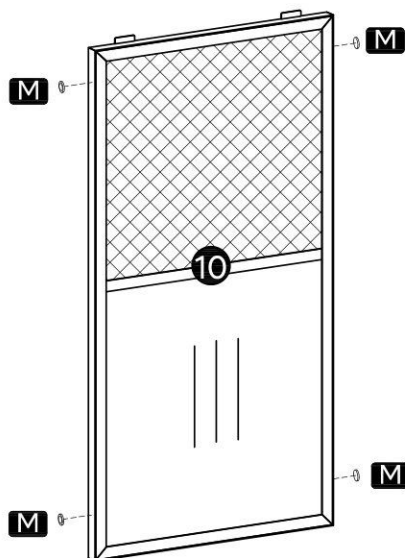

x 2

x 8



M Ø8mm

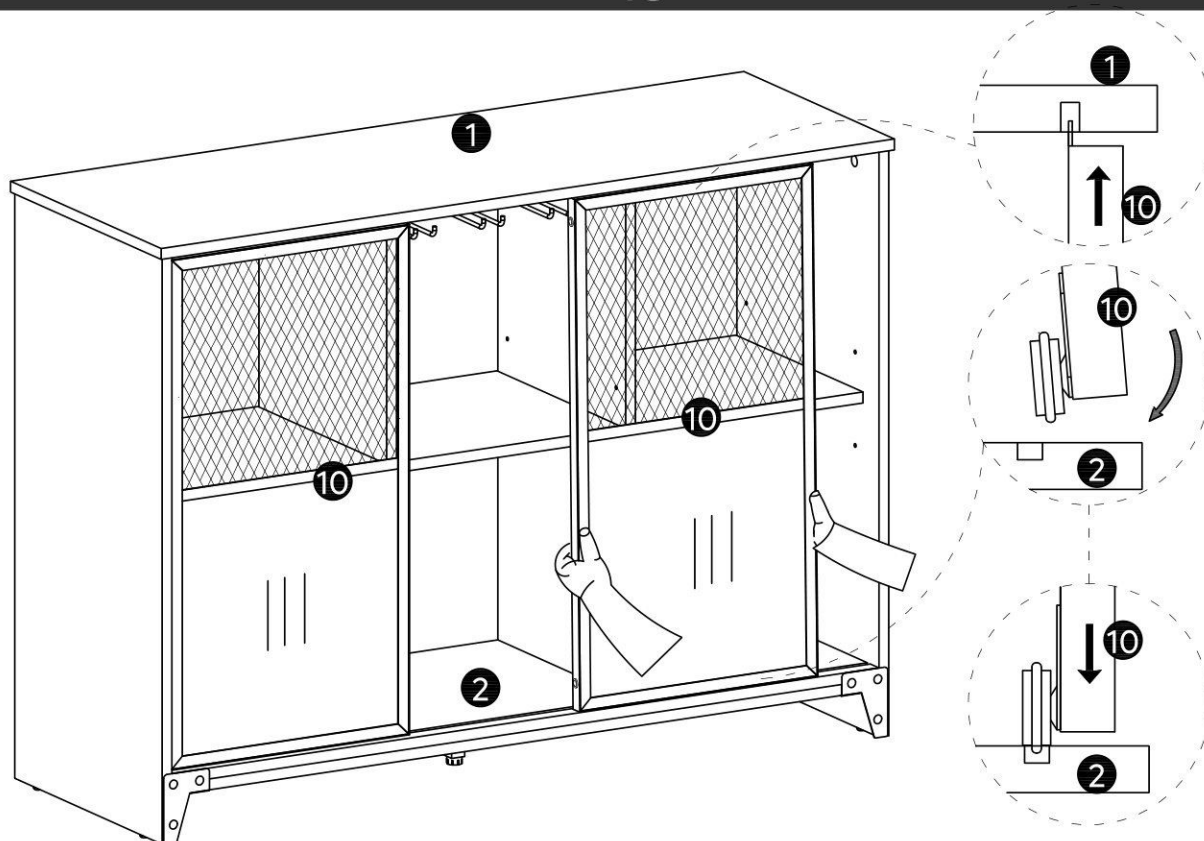

※First fix the No. 10 cabinet door in the top of the groove, and then embedded in the bottom of the bottom plate groove.

※Fixez d'abord la porte d'armoire n° 10 dans la partie supérieure de la rainure, puis encastrée dans la partie inférieure de la rainure de la plaque de fond.

※Befestigen Sie die Schranktür Nr. 10 zunächst oben in der Nut und dann unten in der Nut der Bodenplatte.

※Prima fissare la porta dell'armadietto No. 10 nella parte superiore della scanalatura, e poi incorporata nella parte inferiore della scanalatura della piastra inferiore.

※Primero fije la puerta N.º 10 del mueble en la parte superior de la ranura, y luego insértela en la parte inferior de la ranura de la placa inferior.

※最初に、No. 10キャビネットのドアを溝の上部に固定し、次に底板の底部に埋め込みます。

※Important Note:

Please check whether the sliding wheel is installed into the slideway.

※Important Note :

Veillez vérifier si la roue de glissement est installée dans la glissière.

※Wichtiger Hinweis:

Bitte prüfen Sie, ob das Gleitrad in die Gleitschiene eingesetzt ist.

※Nota importante:

Si prega di controllare se la ruota scorrevole è installata nella guida di scorrimento.

※Nota importante:

Compruebe que la rueda de deslizamiento esté colocada en la guía de deslizamiento.

※重要な注意点:

スライディングホイールが滑り溝に取り付けられていることを確認してください。

※Bitte befestigen Sie diesen Artikel zum Schutz und zur Sicherheit an der Wand.

1. Bohren Sie 2 Löcher in die Wand und setzen Sie die N2 in die Löcher ein.

Position der Löcher: ca. 2" (5 cm) UNTER den entsprechenden Positionen der auf der Stange installierten N3s.

※Möglicherweise müssen Sie einen Gummihammer zum Klopfen von N2 verwenden.

2. Verwenden Sie N1, um N2 mit N3 zu verbinden.

※N2 muss durch das kleinere Loch des N3s gehen und sicherstellen, dass die Lasche mit dem größeren Loch nach OBEN zeigt.

3. Verwenden Sie N4, um die entsprechenden N3s zu verbinden, und ziehen Sie sie wie gewünscht fest, bevor Sie sie verriegeln.

※Si prega di fissare questo articolo alla parete per protezione e sicurezza.

1. Praticare 2 fori nella parete e inserire N2 nei fori.

Posizione dei fori: circa 2"/5 mm SOTTO le posizioni corrispondenti del pezzo N3 installato sulla barra.

※Potrebbe essere necessario usare un martello di gomma per fissare il pezzo N2.

2. Utilizzare N1 per collegare N2 con N3.

※N1 deve passare attraverso il foro più piccolo di N3, facendo in modo che la linguetta con il foro più grande sia VERSO L'ALTO.

3. Utilizzare N4 per collegare i N3 corrispondenti e stringerli a proprio piacimento prima di bloccarli in posizione.

※Fije este elemento a la pared como medida de protección y seguridad.

1. Taladre 2 orificios en la pared e inserte el tornillo N2 en los orificios.

Posición del orificio: aproximadamente 2" POR DEBAJO de las posiciones correspondientes de N3 instalado en la barra.

※Es posible que tenga que utilizar el mazo de goma para golpear N2.

2. Utilice N1 para unir N2 con N3.

※N1 debe atravesar el pequeño orificio de N3. Asegúrese de que la aleta con el orificio mayor esté orientada HACIA ARRIBA.

3. Utilice N4 para conectar los N3 correspondientes, y apriételos según sus preferencias antes de inmovilizarlos en su posición.

※安全のために、オープンシェルフを壁に固定してください。

1、壁に2つ穴を開け、N2を穴に差し込む。

穴位置: オープンシェルフに設置されるWCに対応する位置、またその位置のおよそ2インチ下にしてください。

※N2を叩くにはラバーハンマーが必要かもしれません。

2、N1を使用し、N2とN3を接続してください。

※N1はN3の小さな穴を通り抜け、大きい穴のラベルが上を向いていることを確認する必要があります。

3、N4を使用して二つのWCを接続し、所定の位置にロックする前に必要に応じて締め付ける。

