

Assembly Instructions

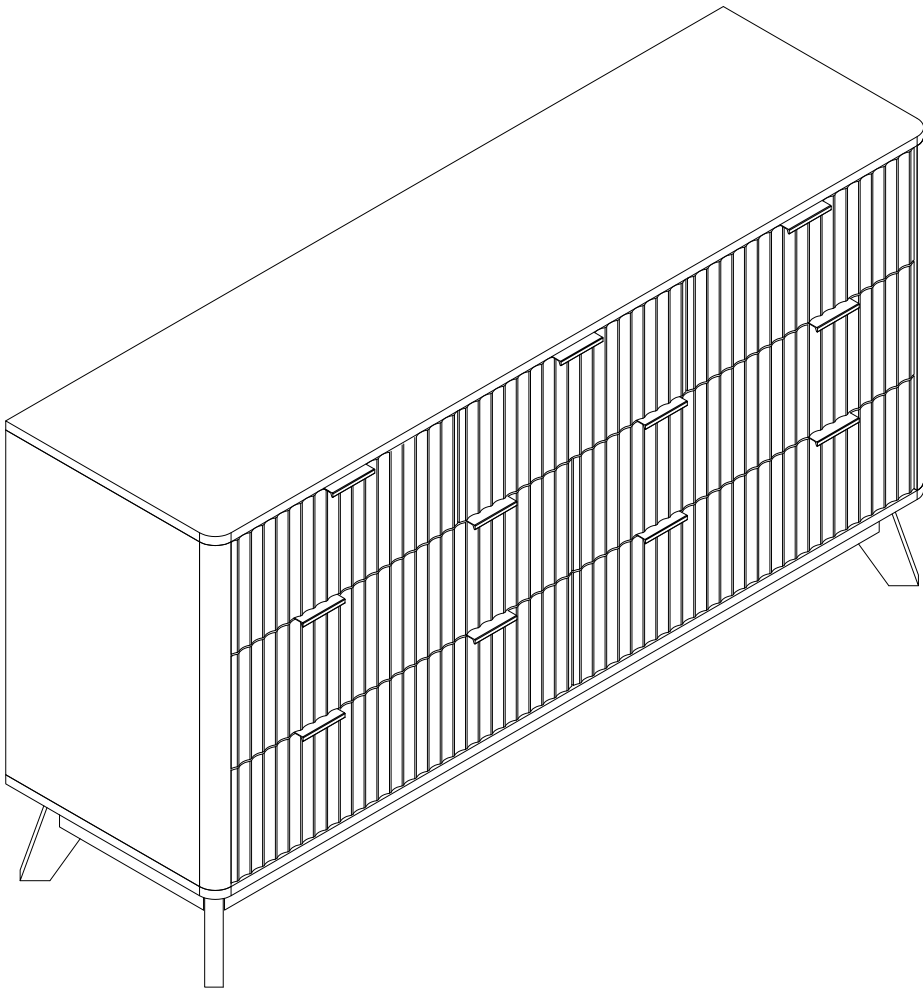

Grantee:



DO NOT RETURN: Keep the regular item and get a Replacement and new products instead of Return.



REFUND: Any problems caused by us can be compensated by a refund.

We are very sorry if we have caused you any trouble.
Try to contact our service team at first time to solve your problem.
Thank you for giving our service team another chance.
Thank you for your patience and cooperation.

Before Start:



Check part List: Check the part list to make sure you have all parts before starting assembly



Cursory glance: A cursory glance through the manual can help speed up the installation process and reduce mistakes before starting



Follow Instructions: Follow instructions step by step to avoid Unnecessary mistakes, destruction and failure.

Recommended:



Two Person may help assemble work easier.



Phillips and hexagonal screwdriver.



Power tools can reduce installation time.

Disassemble diagram:

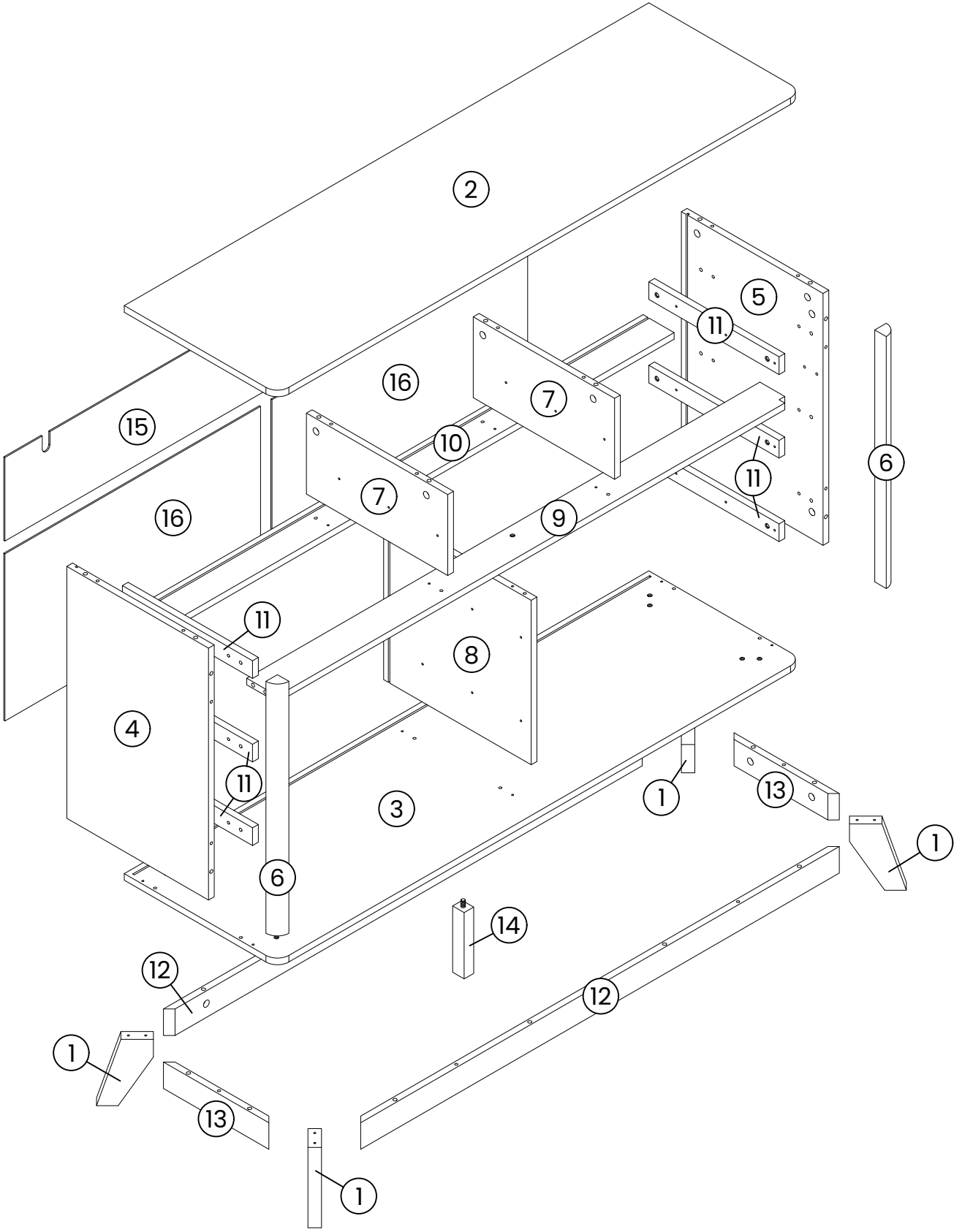

Disassemble diagram:

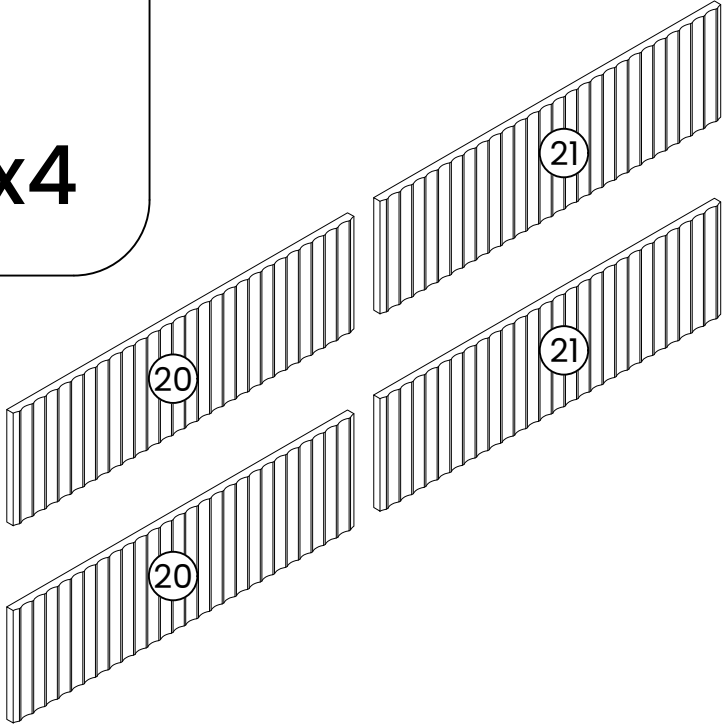
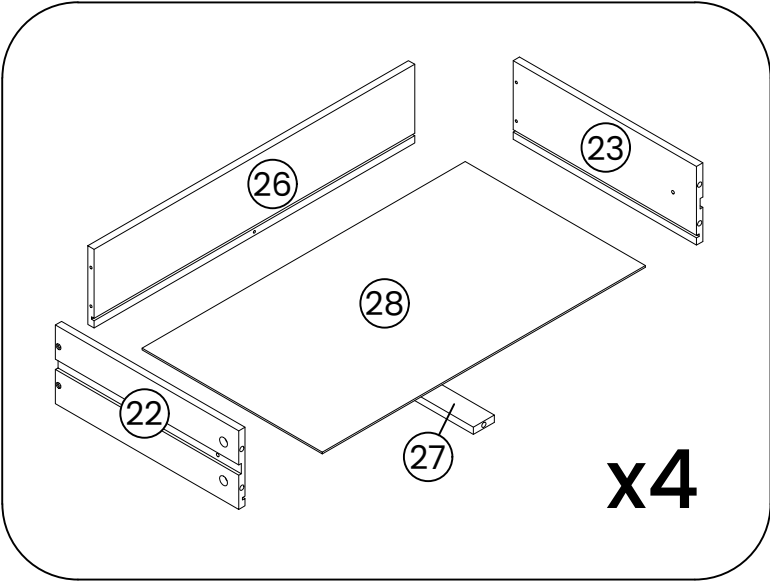
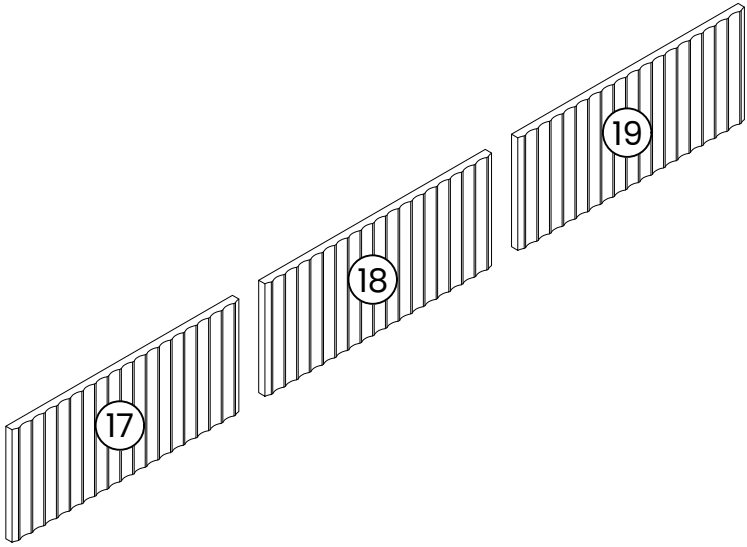
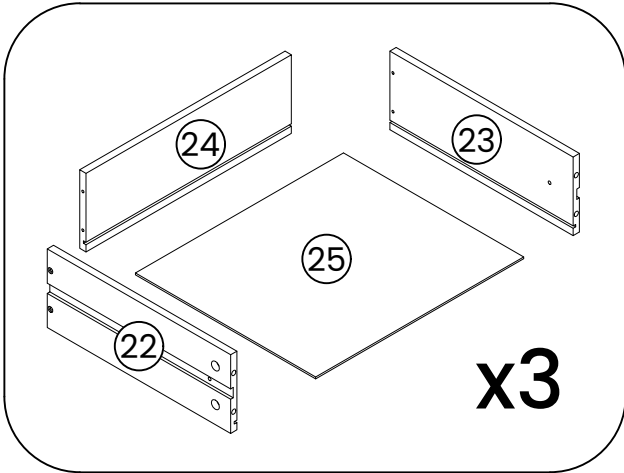

Hardware Part List

A  M6x35mm x64+3

B  M15x10mm x64+3

C  M6x30mm x30+3

D  x14

E  M3x12mm x64+4

F  M6x10mm x12+1

G  M6x20mm x12+1

H  x1

I  x4

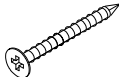
J  M4x35mm x14+1

K  M4x12mm x6

L  x2

M  M4x30mm x32+3

N  x11

O  x12

P  M3x16mm x12+1

Q  x2

R  M4x9mm x14+1

S  x1

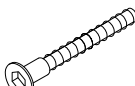
T  M7x50mm x8

U  x1

Components Part List

1



x4



9

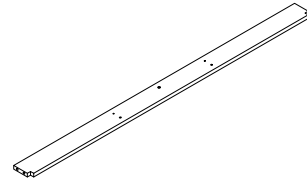

x1



2

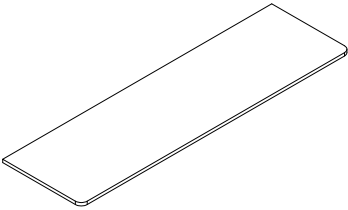

x1



10

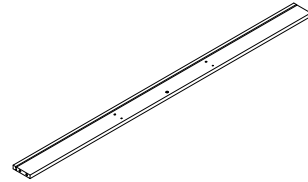

x1



3

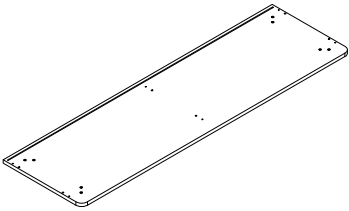

x1



11

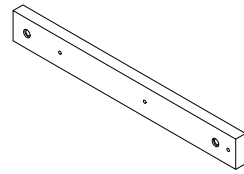

x6



4

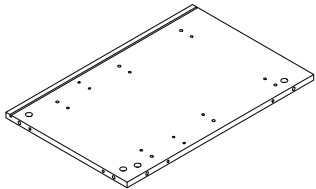

x1



12

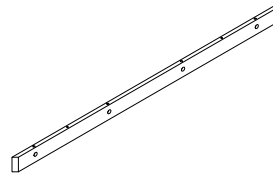

x2



5

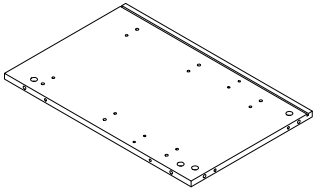

x1



13

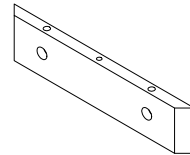

x2



6

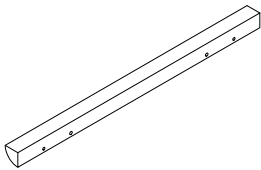

x2



14



x1



7

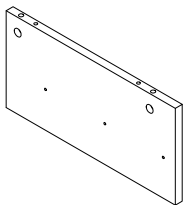

x2



15

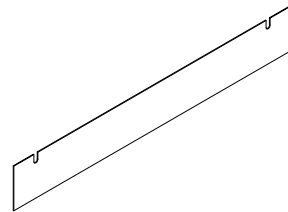

x1



8

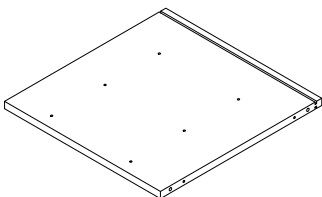

x1



16

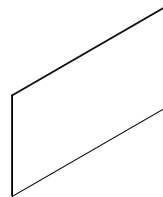

x2



Components Part List

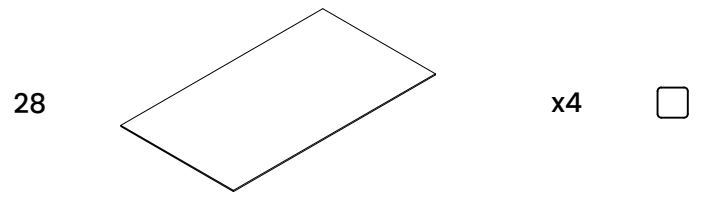
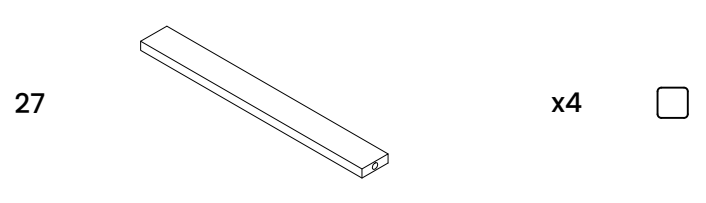
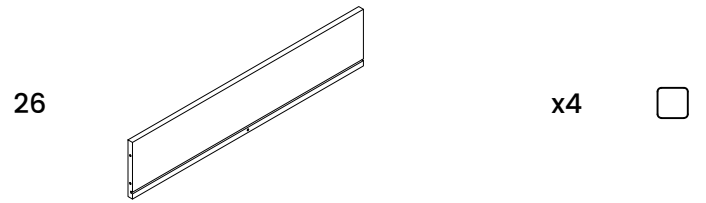
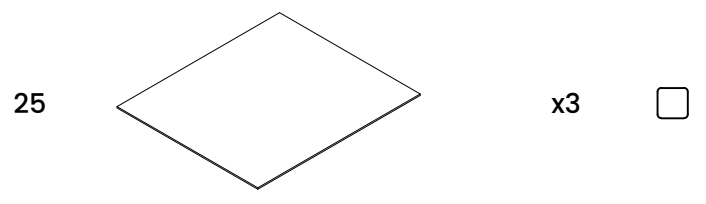
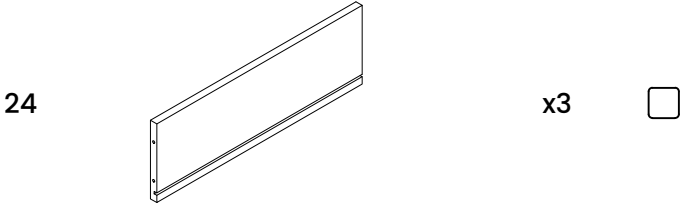
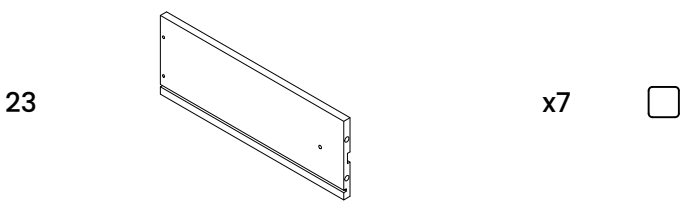
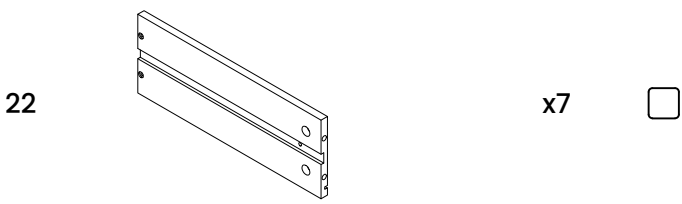
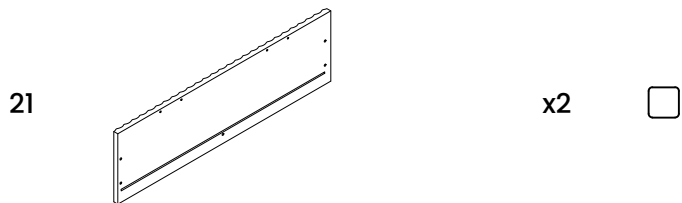
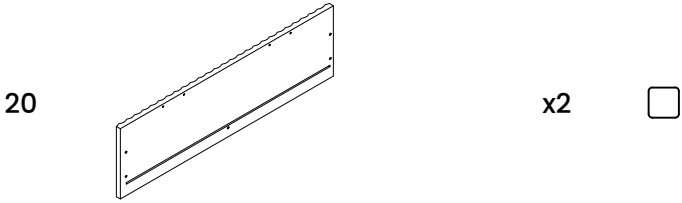
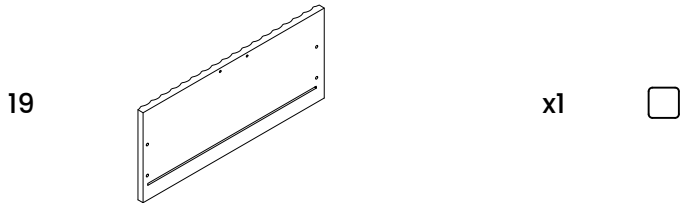
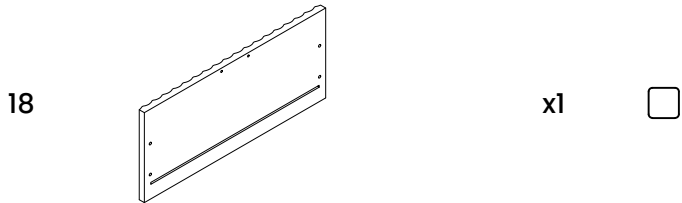
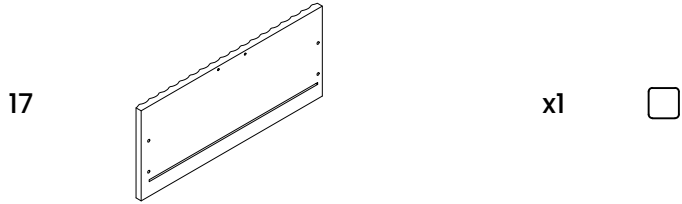

Step 1 / 34

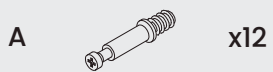
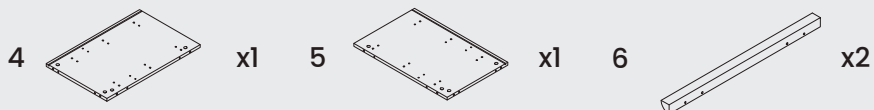
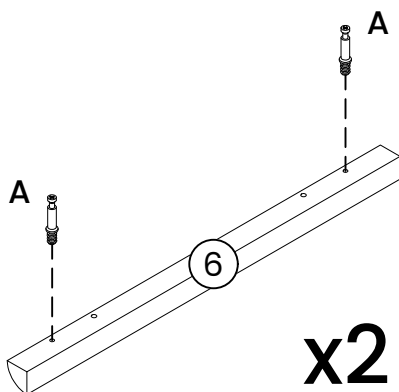
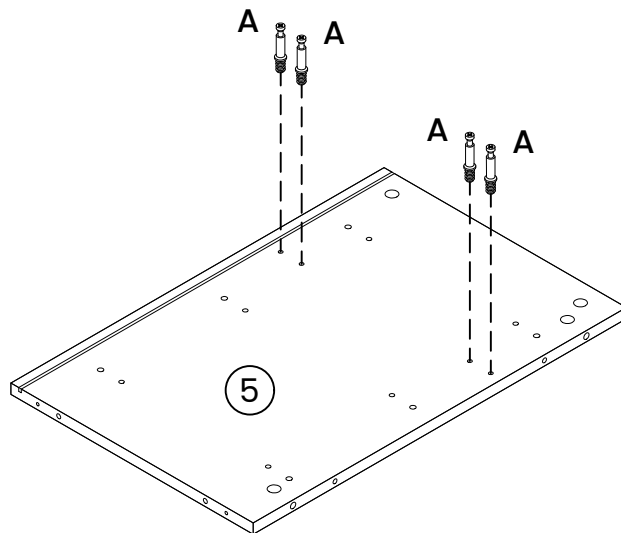
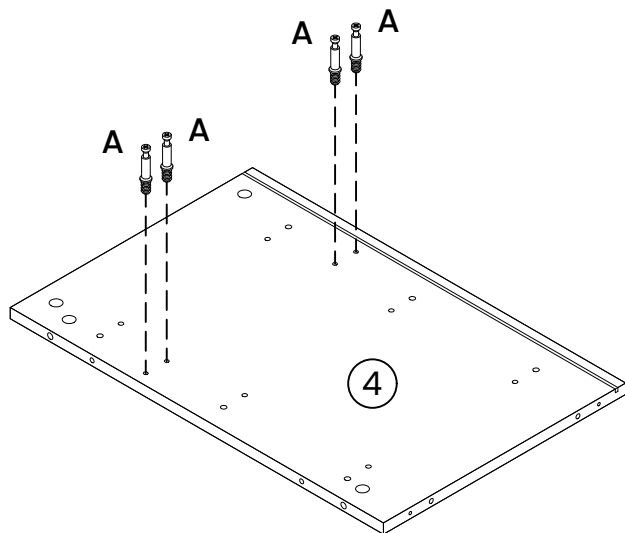

Note:

Step 2 / 34

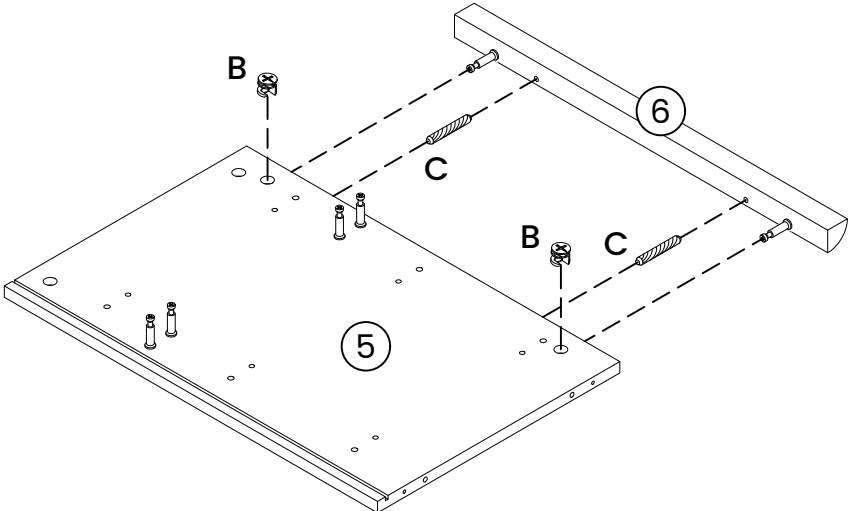
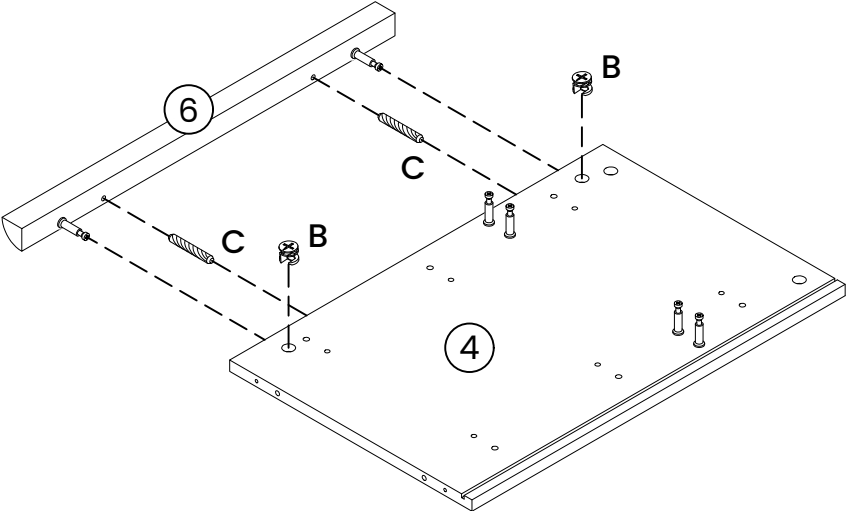

B  x4

C  x4

Note:

Step 3 / 34

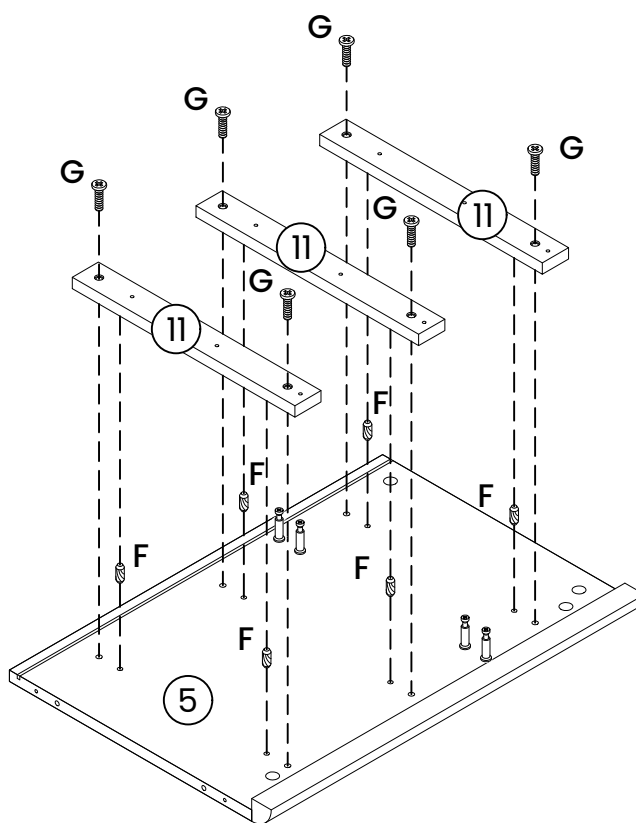
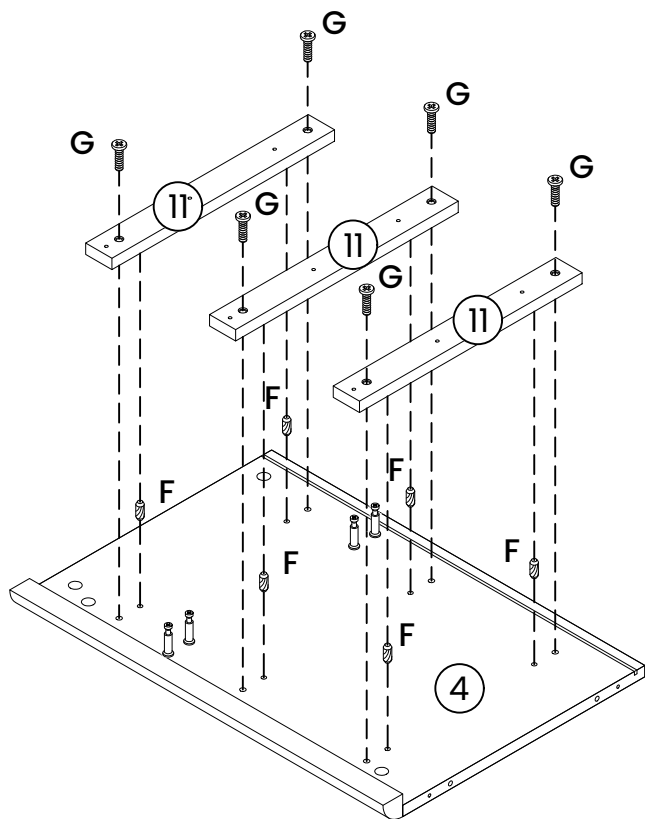

11 x6

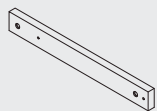

F x12 G x12



Note:

Step 4 / 34

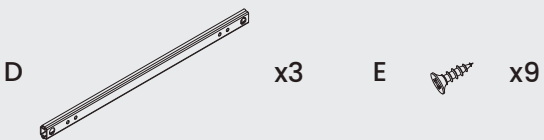
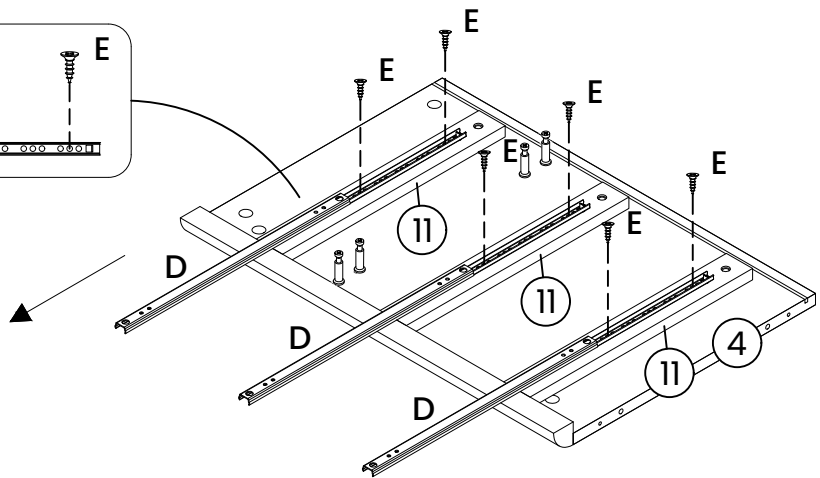
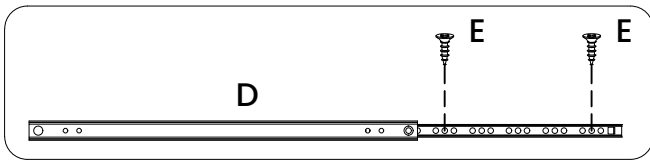
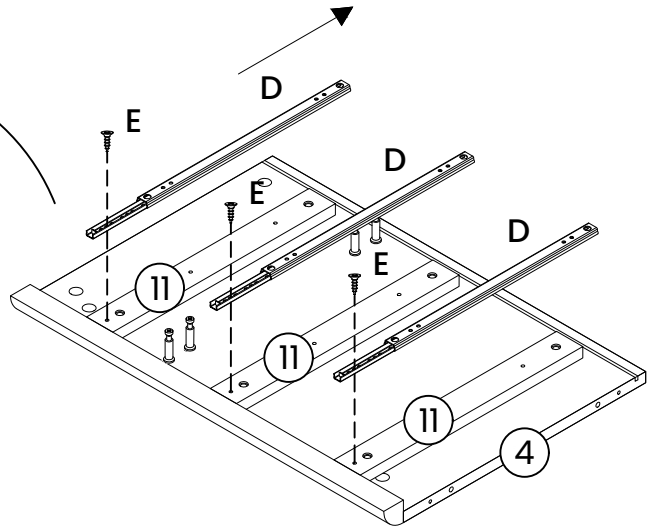
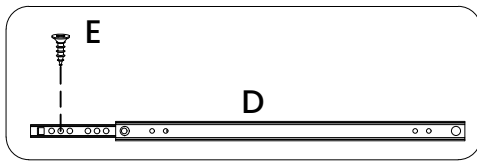

Note:

To locate correct holes, slide(D) needed to be moved in 2 directions.

Step 5 / 34

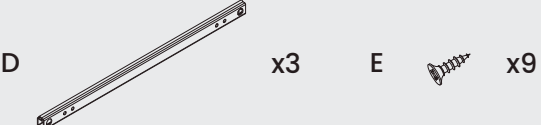
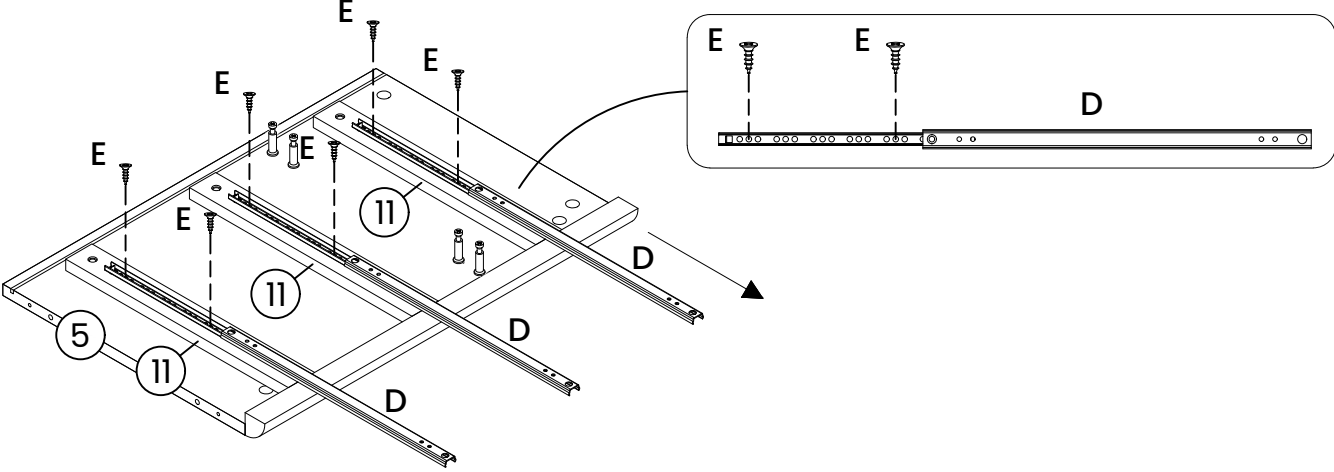
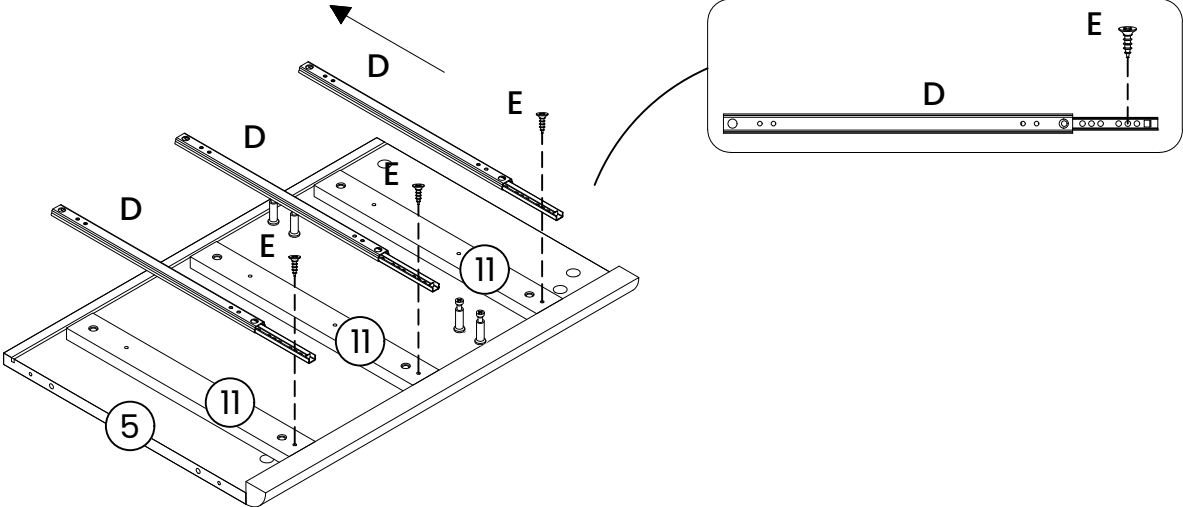

Note:

To locate correct holes, slide(D) needed to be moved in 2 directions.

Step 6 / 34

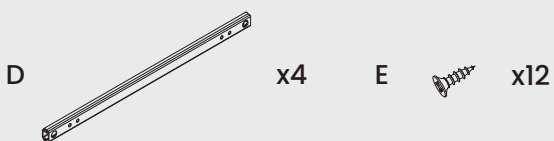
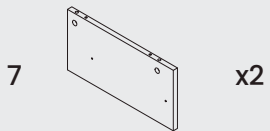
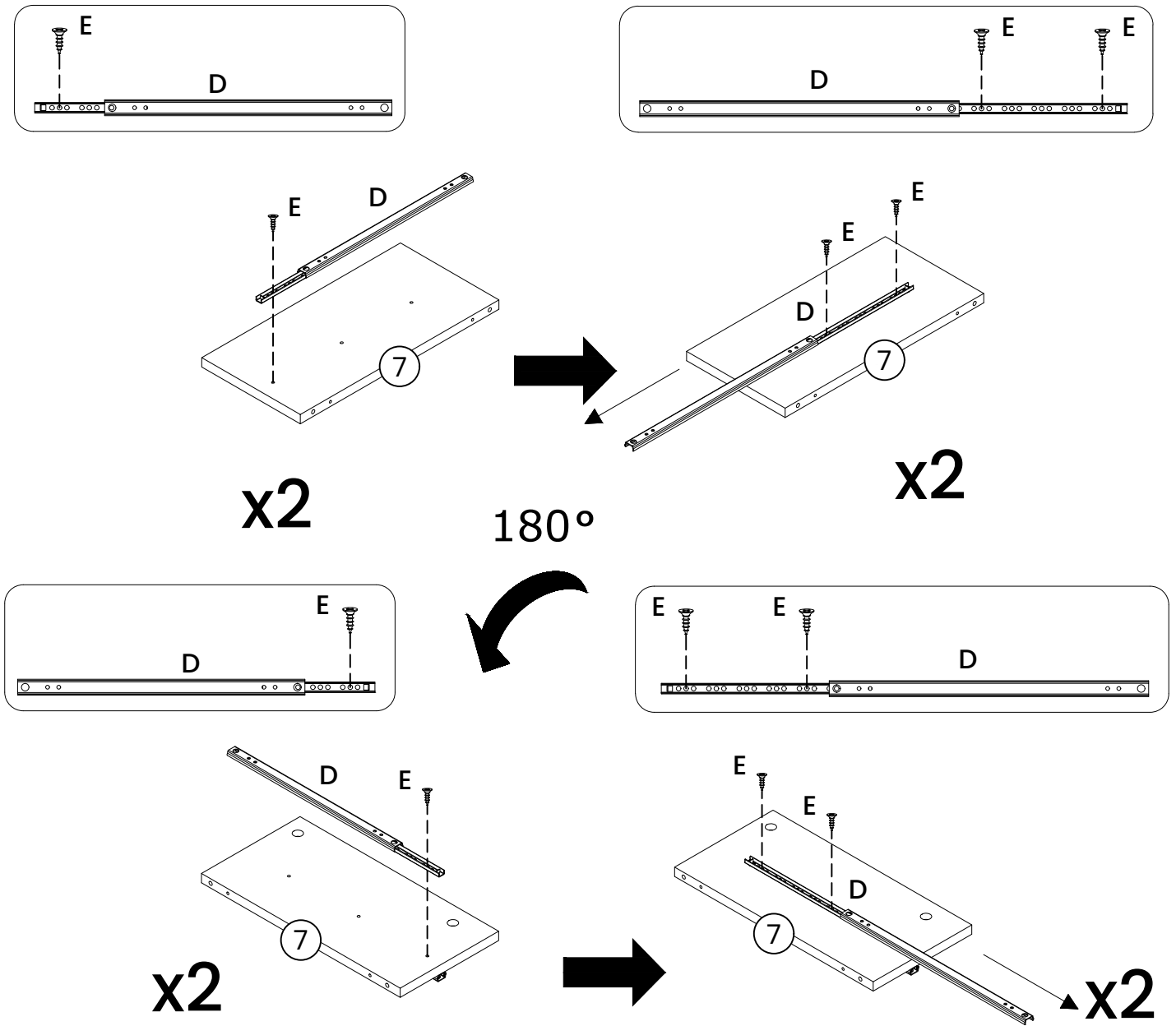

Note:

Both sides of part 7 needed to be installed.

To locate correct holes, slide(D) needed to be moved in 2 directions.

Step 7 / 34

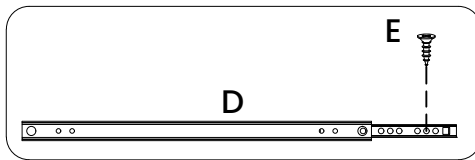
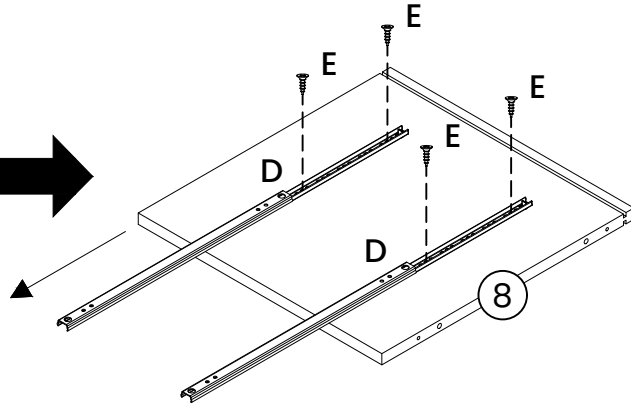
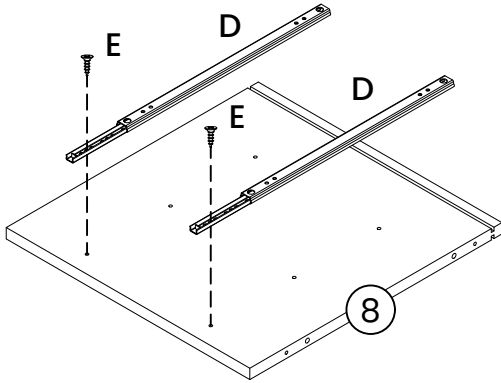
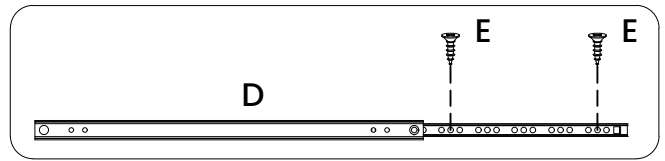
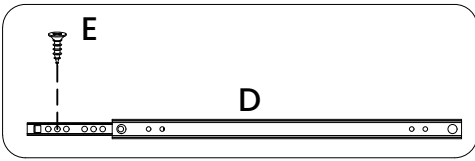

180°

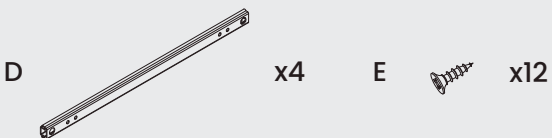
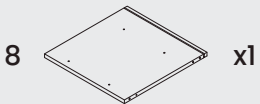
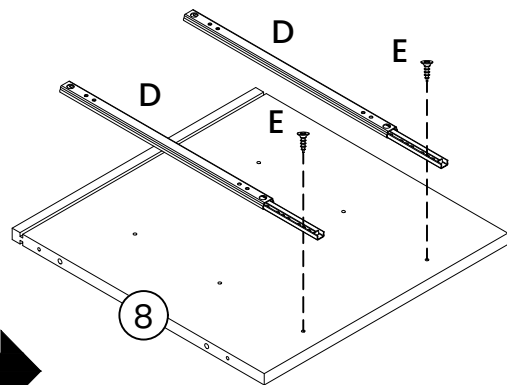
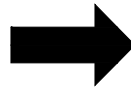
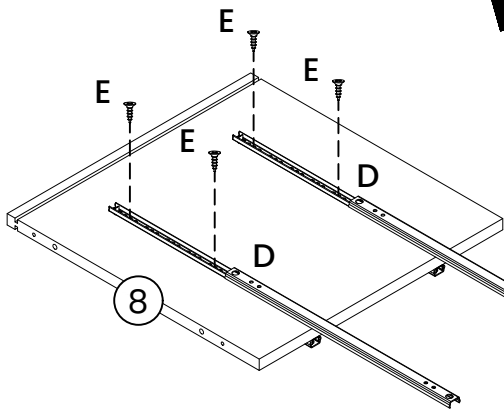
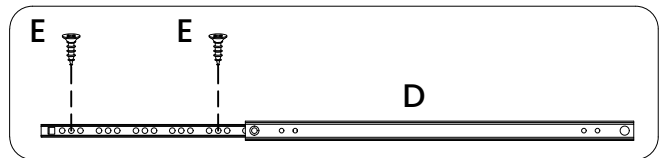

Note:

Both sides of part 8 needed to be installed.

To locate correct holes, slide(D) needed to be moved in 2 directions.

Step 8 / 34

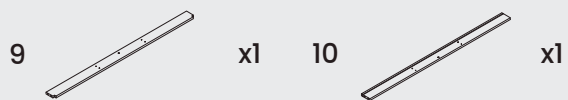
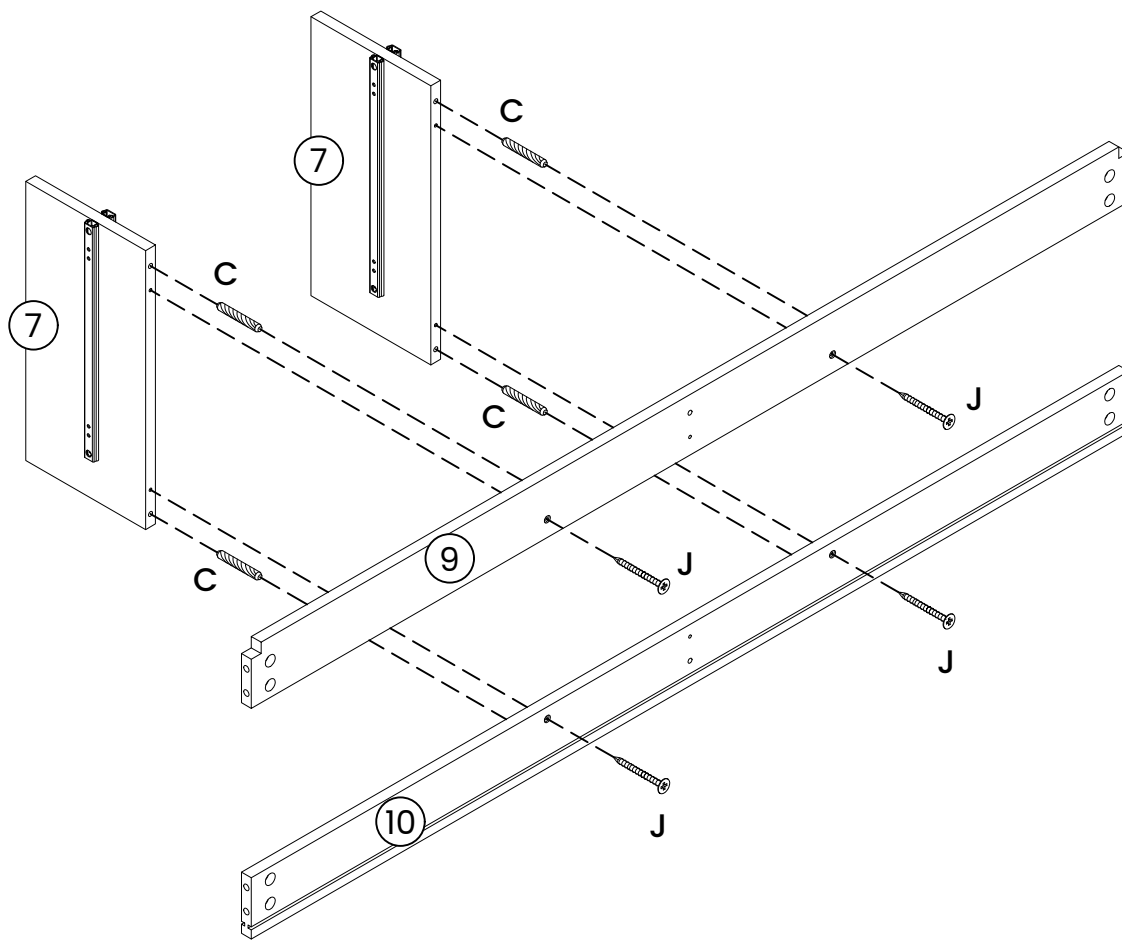

Note:

Step 9 / 34

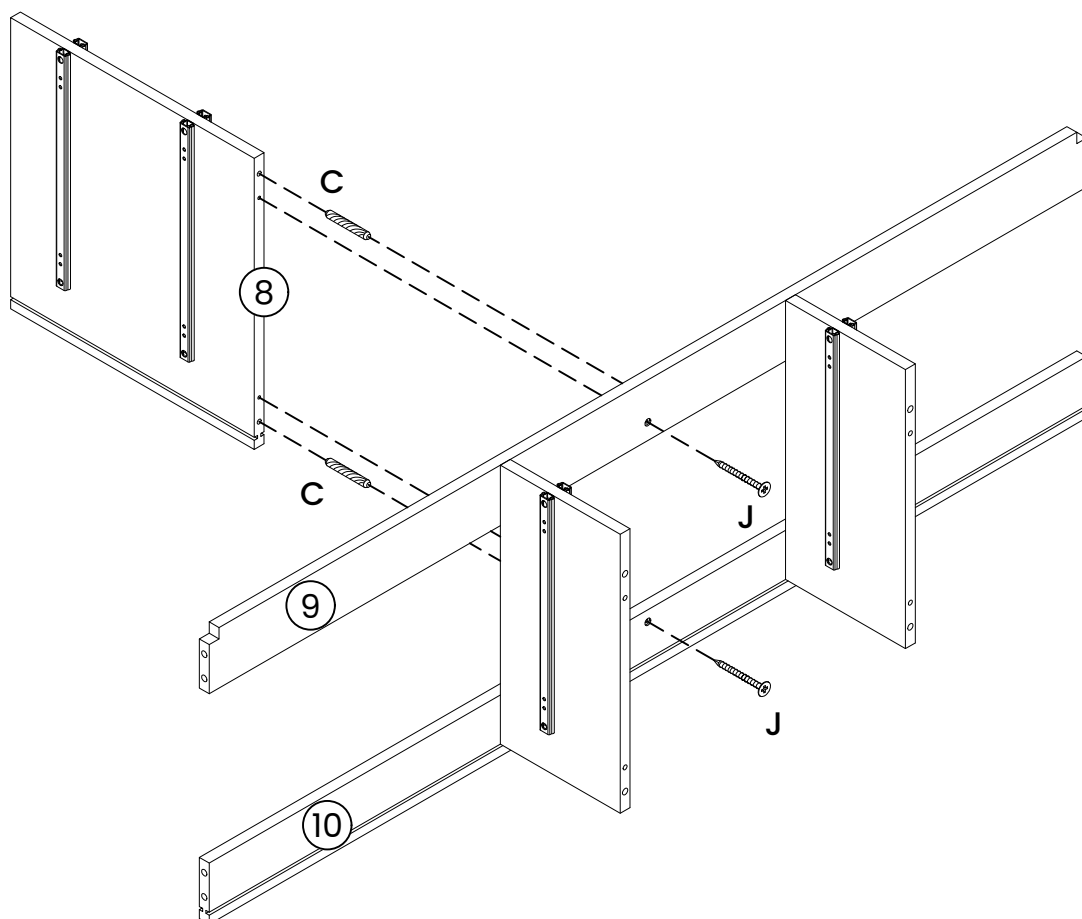

x2

J



x2

Note:

Step 10 / 34

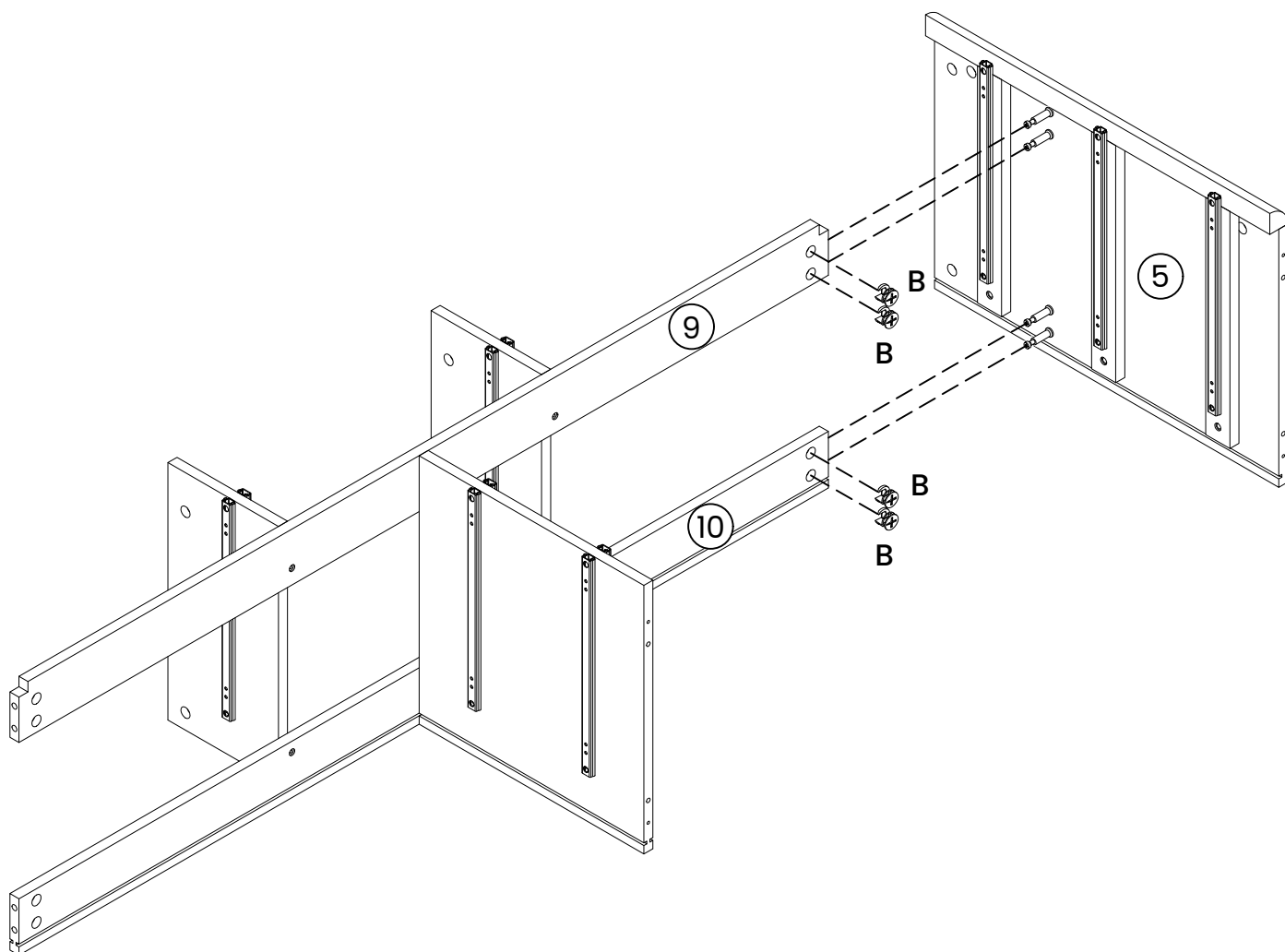

B  x4

Note:

Step 11 / 34

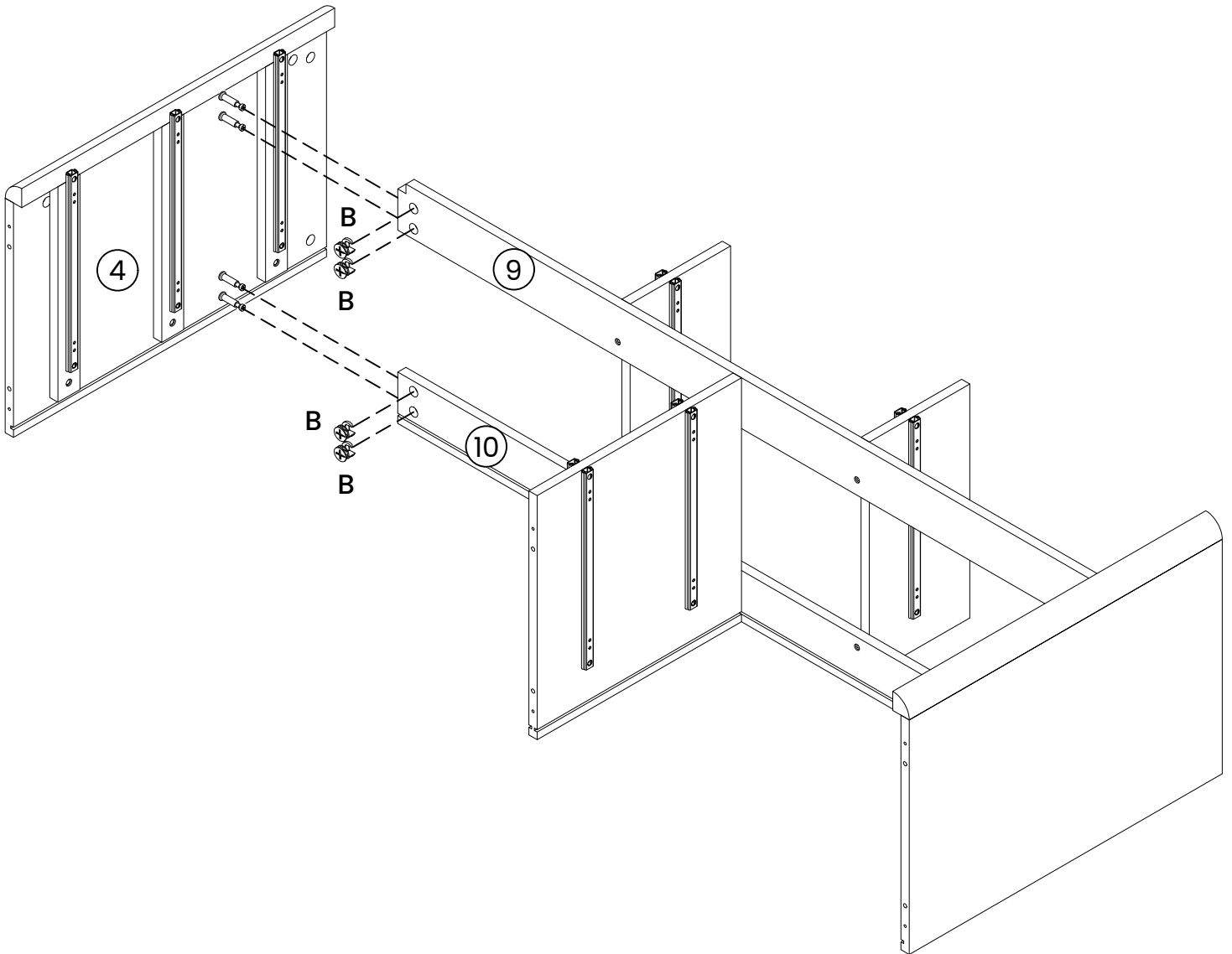

B  x4

Note:

Step 12 / 34

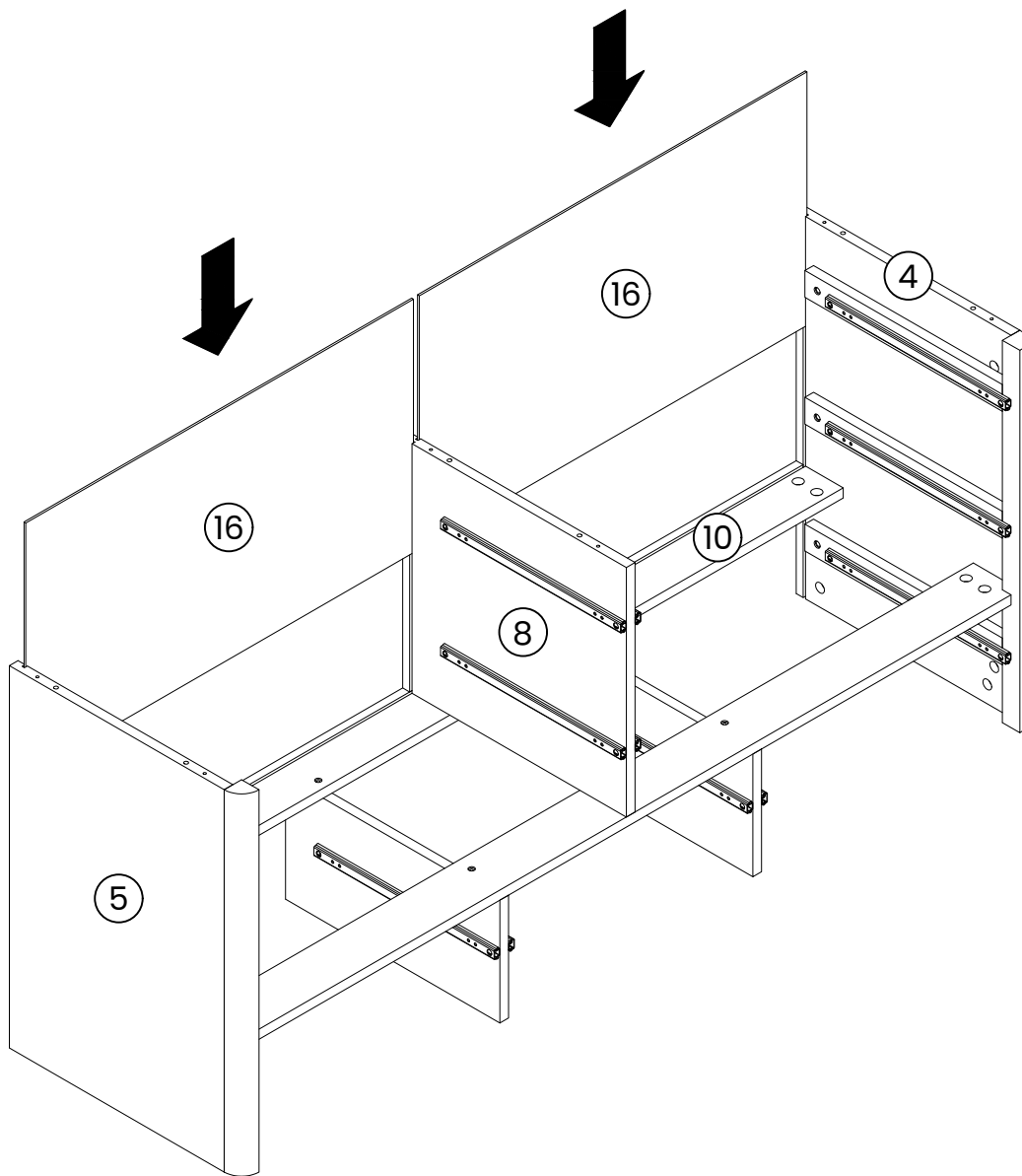

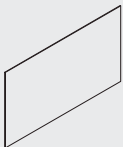

16 x2



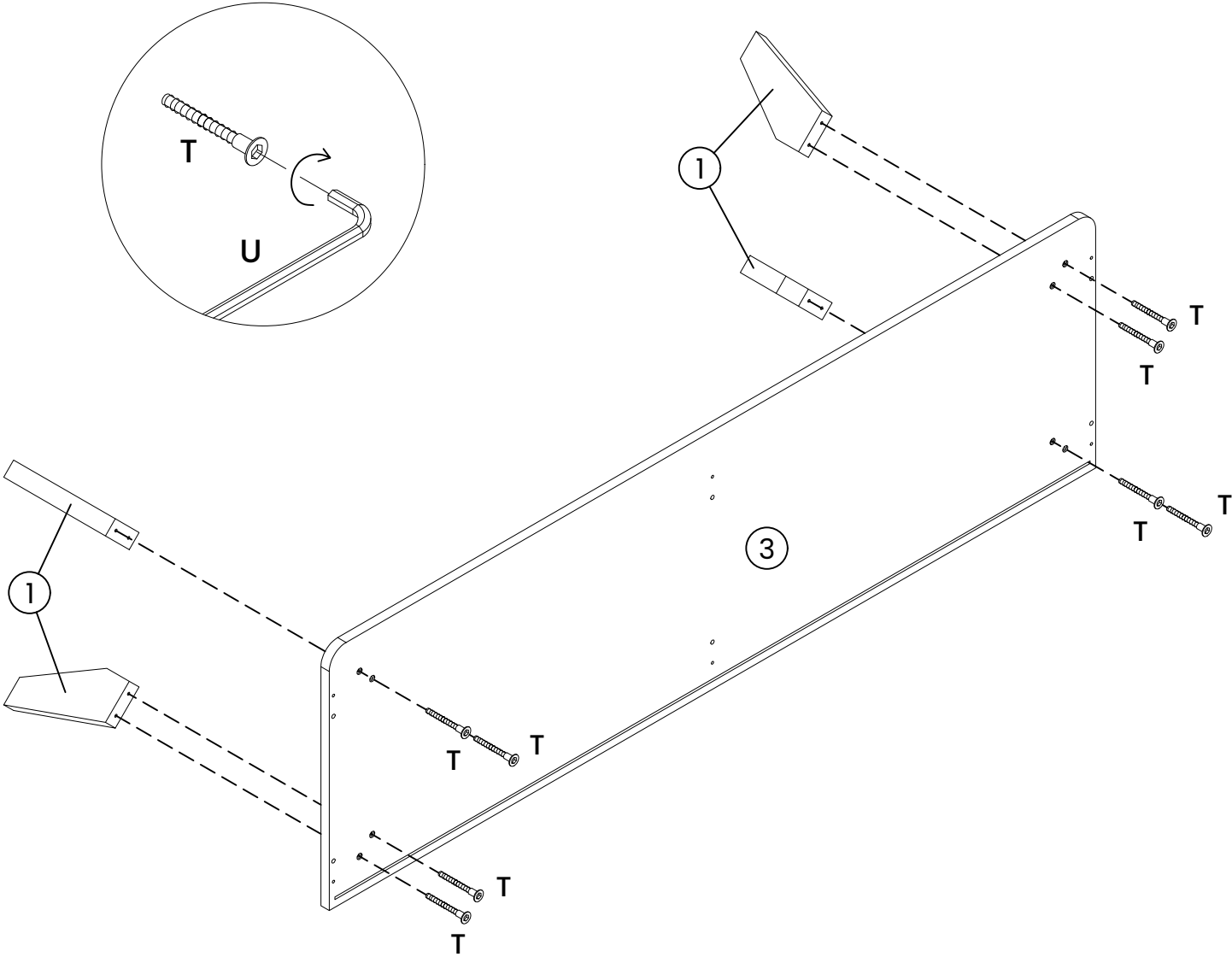

Note:

Step 13 / 34



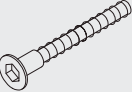

- 1  x4
- 3  x1

- T  x8
- U  x1

Note:

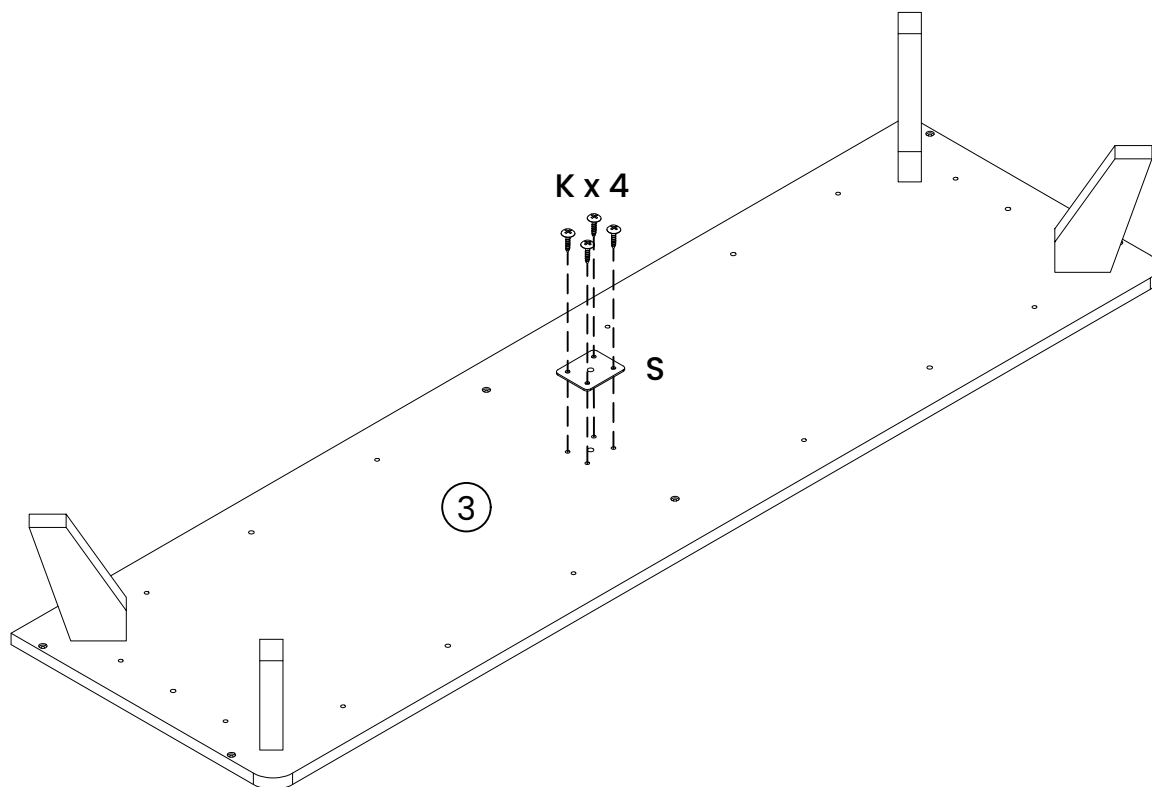
Step 14 / 34



K  x4 S  x1

Note:

Step 15 / 34

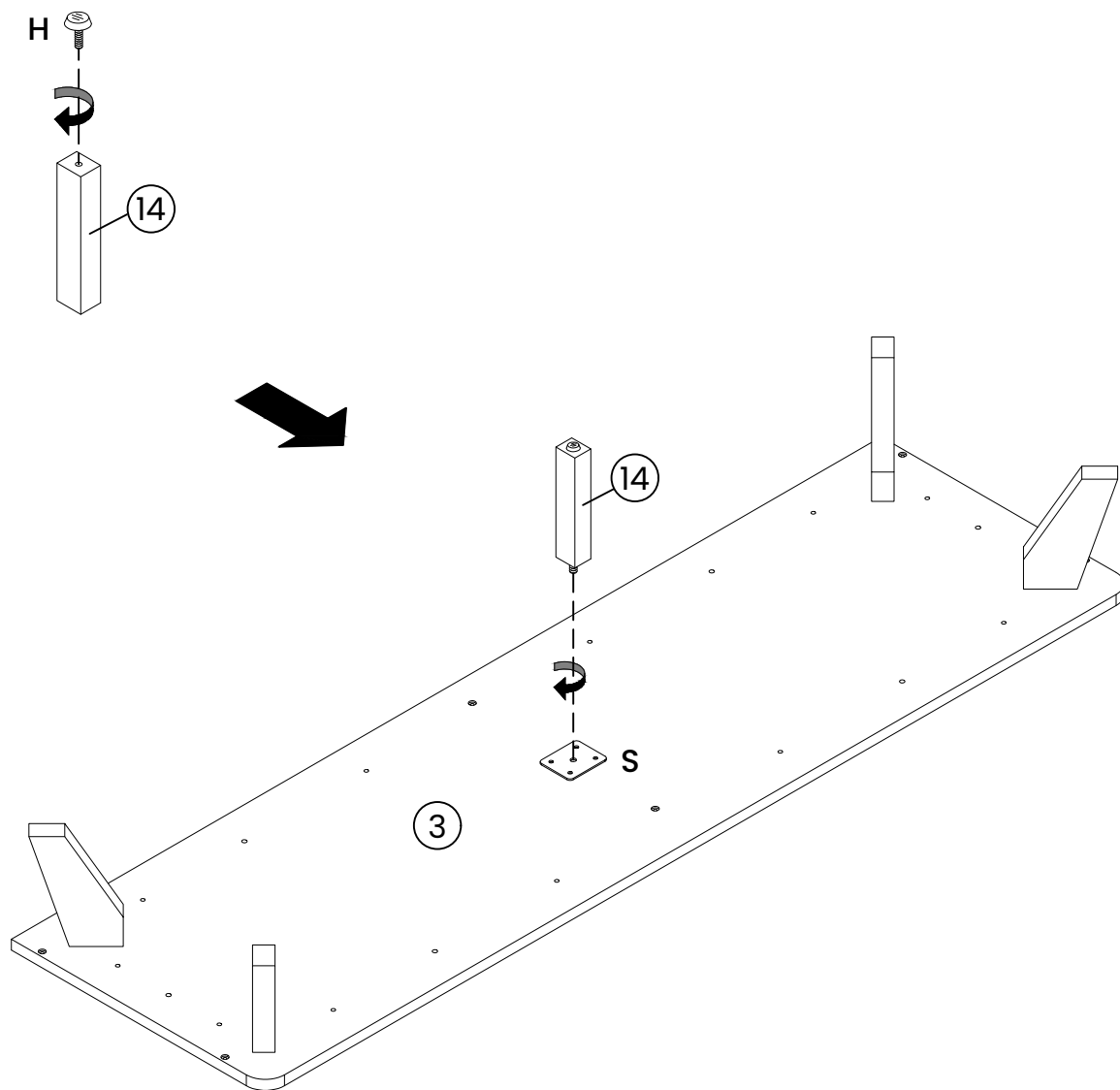

14



x1

H



x1

Note:

Step 16 / 34

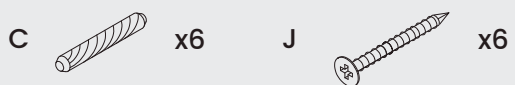
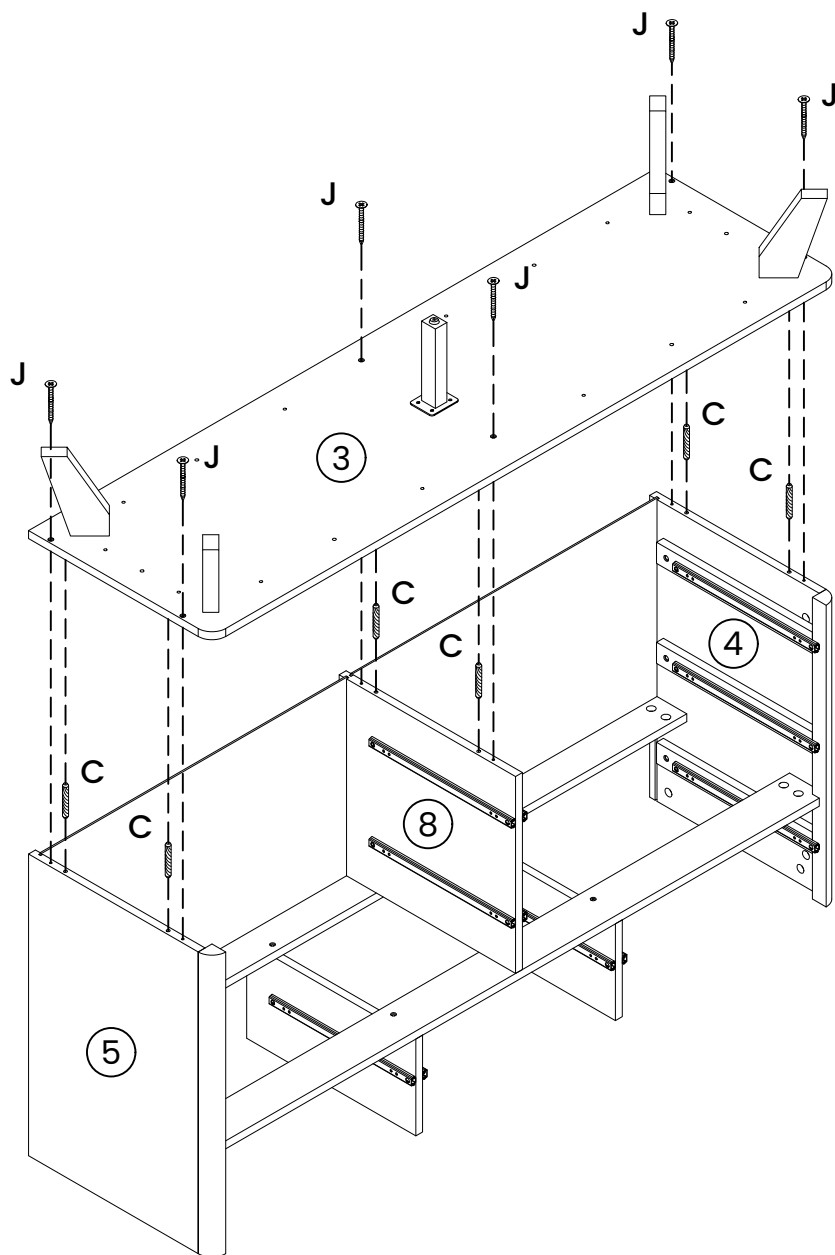

Note:

Two persons required.

Step 17 / 34

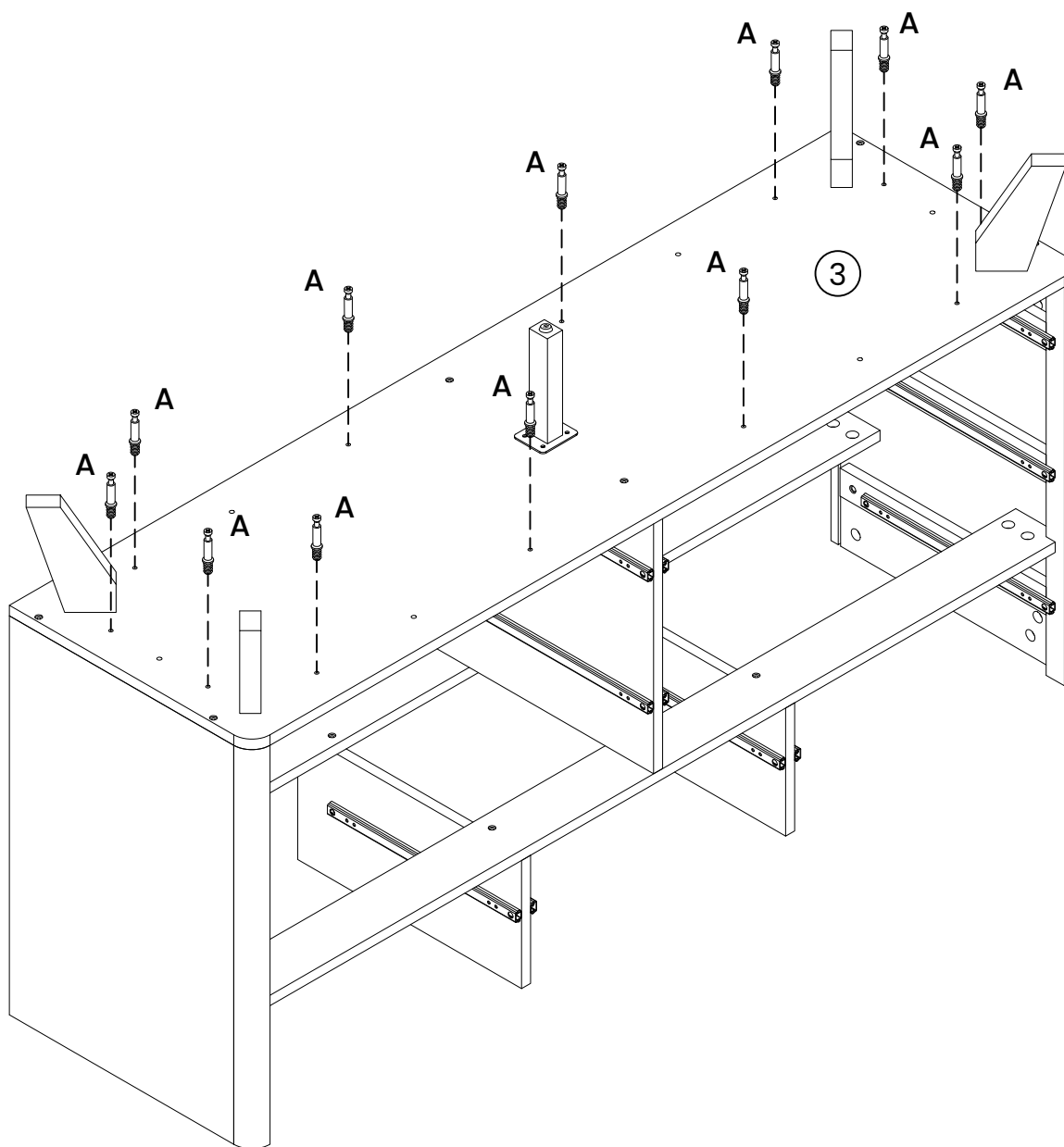

A  x12

Note:

Step 18 / 34

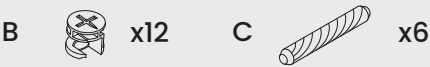
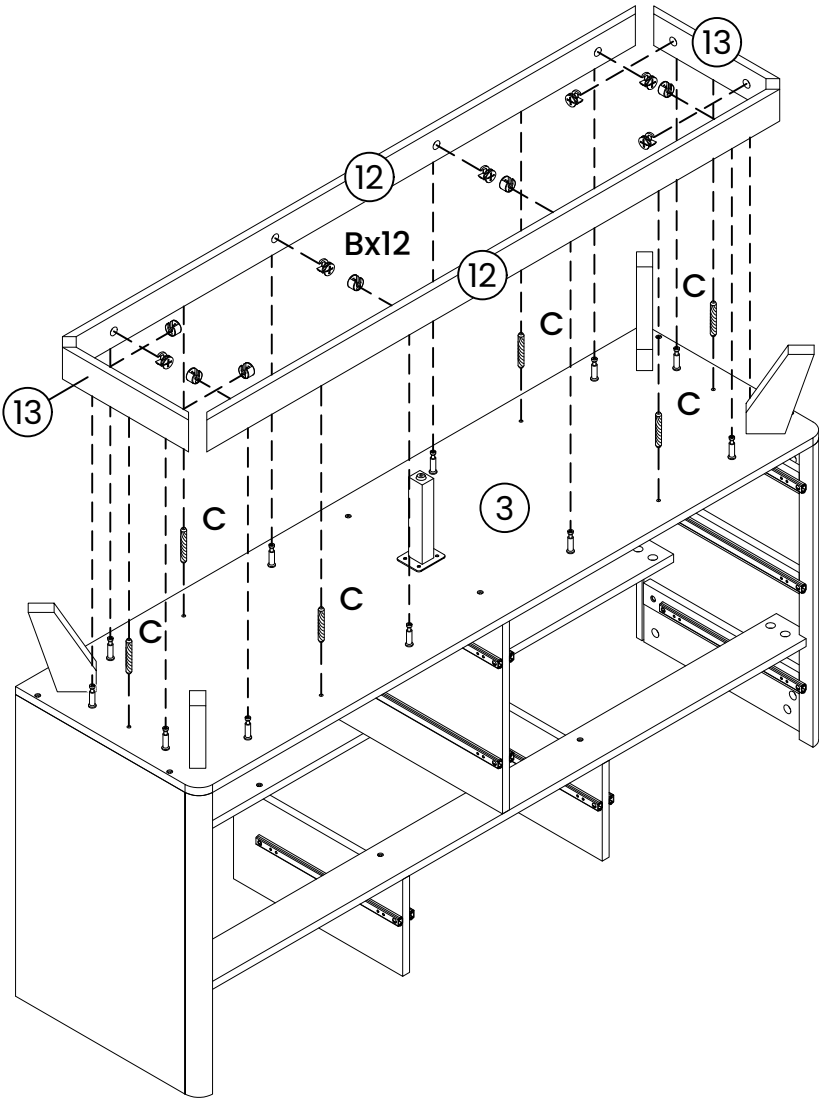

Note:

Step 19 / 34

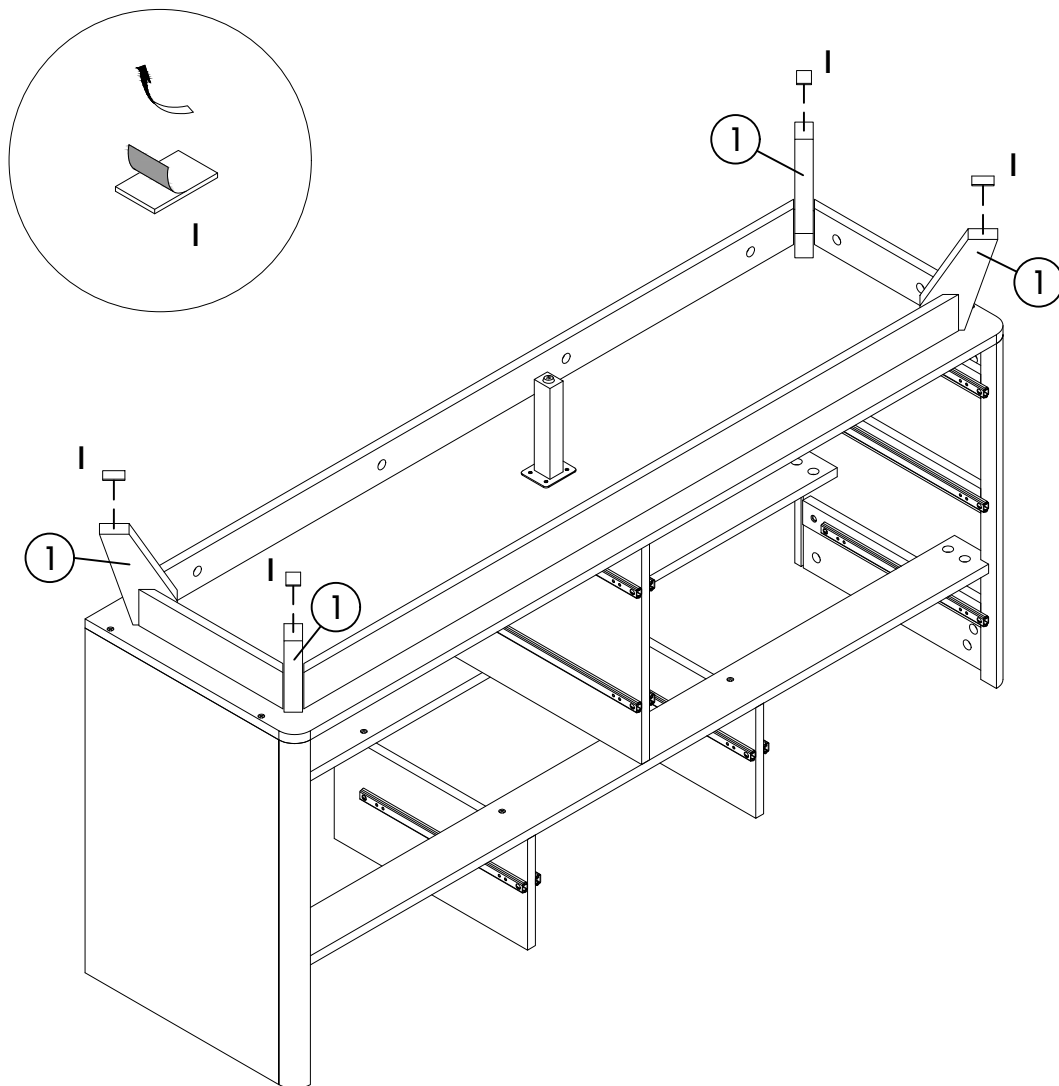

1  x4

Note:

Step 20 / 34

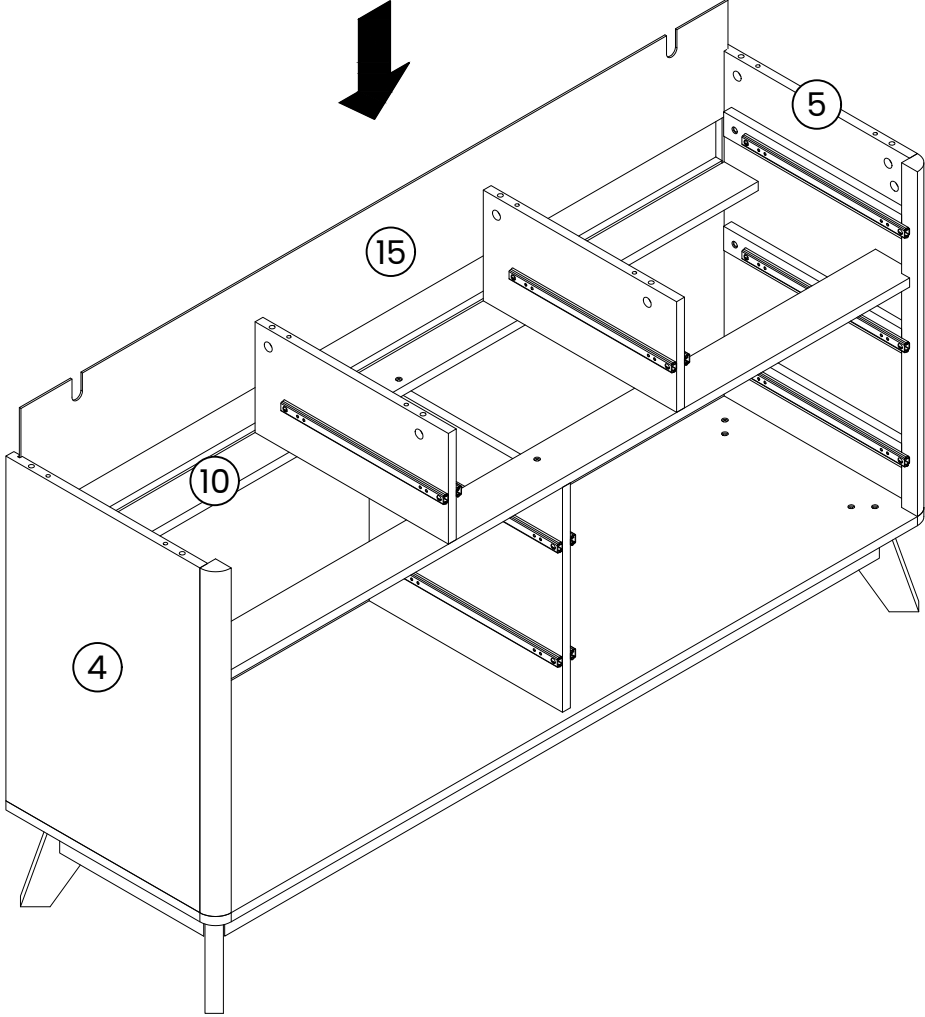

15



x1

Note:

Step 21 / 34

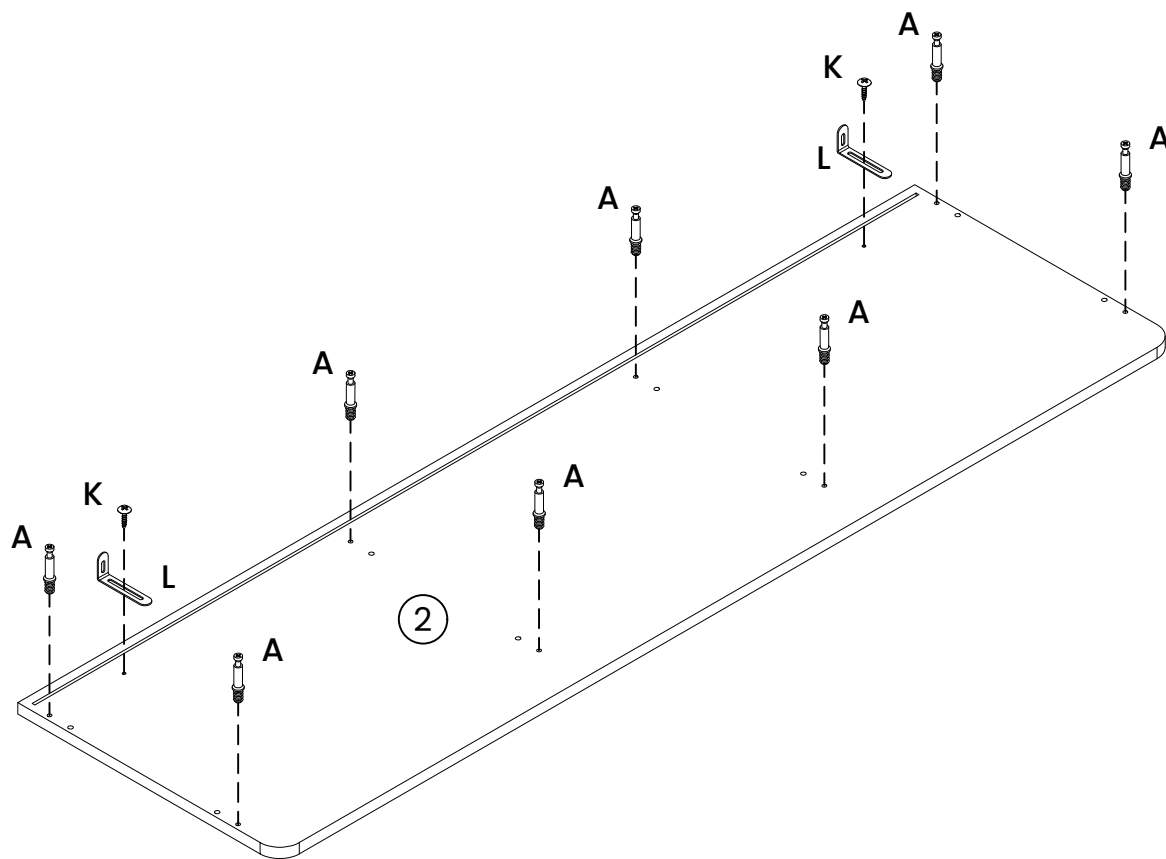

2 x1

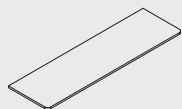

A x8



K x2



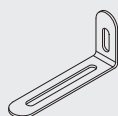

L x2

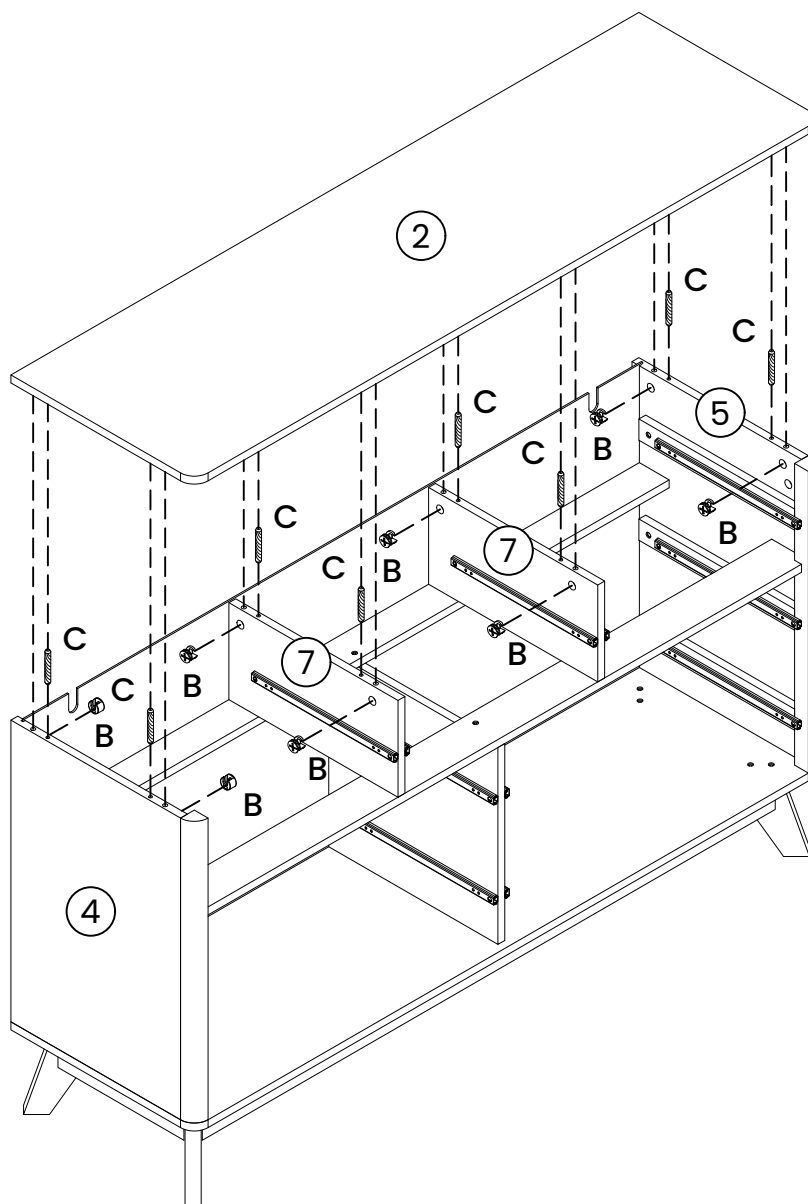

Note:

Step 22 / 34



B  x8 C  x8

Note:

Two persons required.

Step 23 / 34

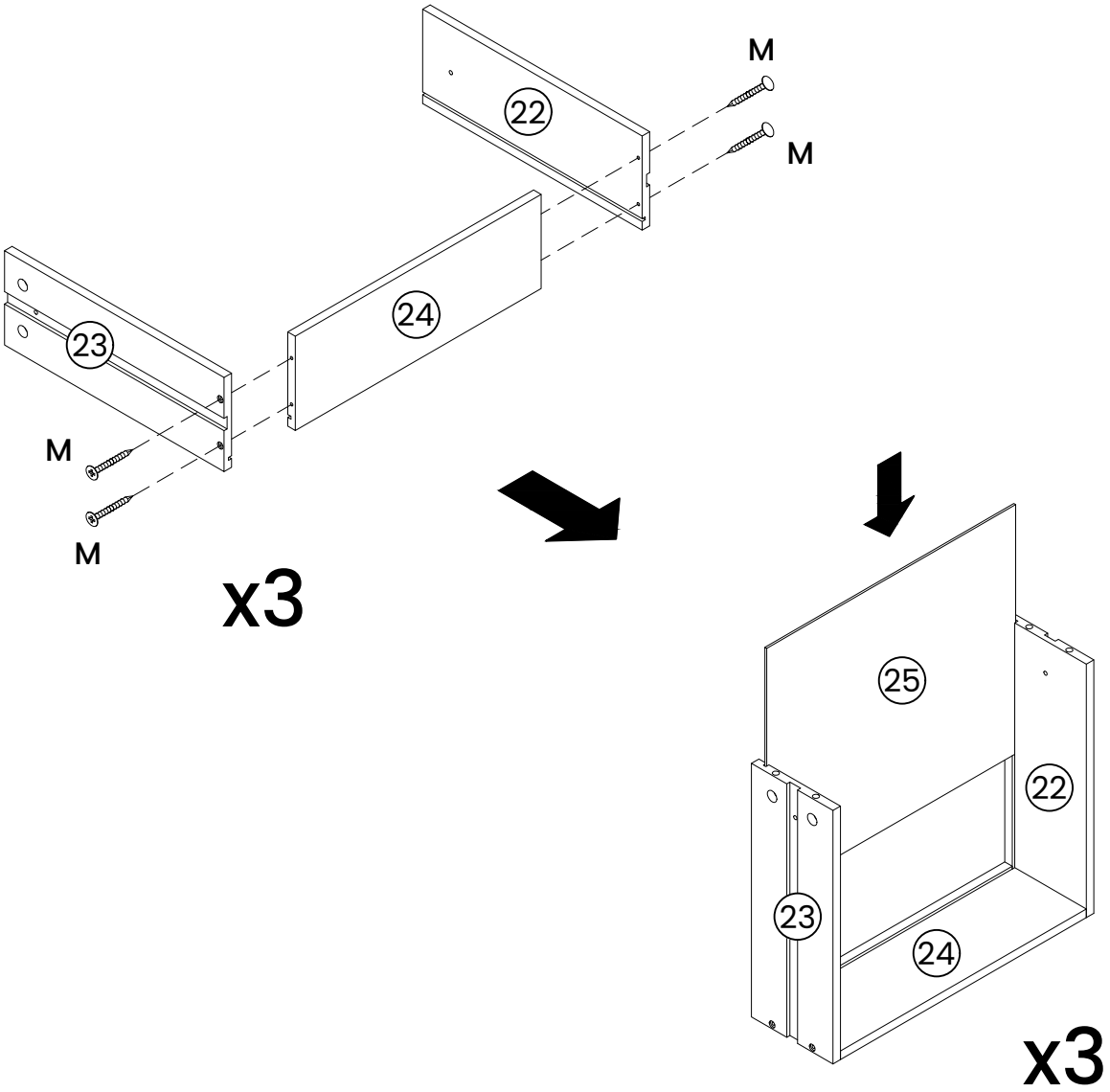

- 22  x3
- 23  x3
- 24  x3
- 25  x3

- M  x12

Note:

Step 24 / 34

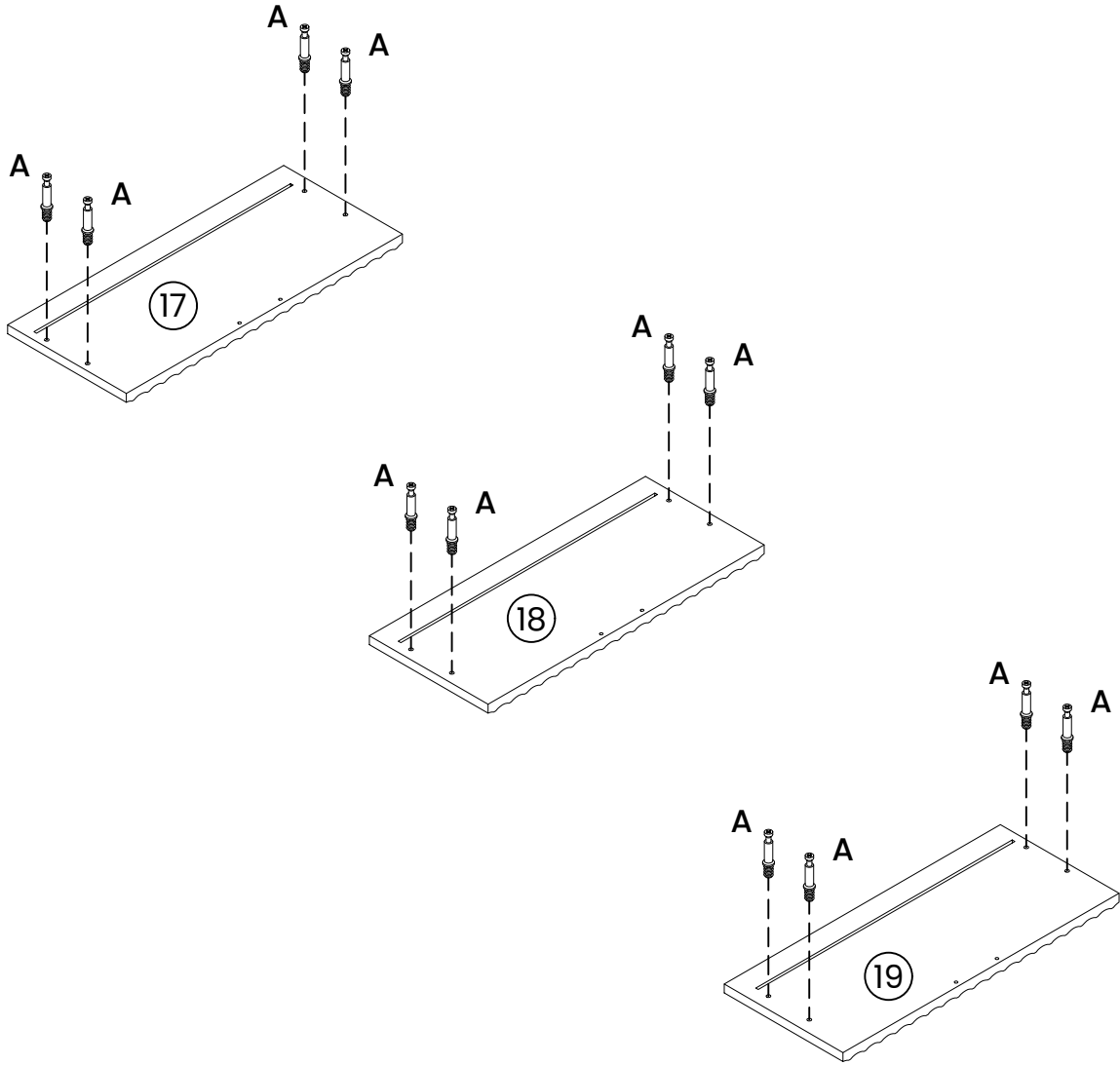

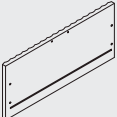
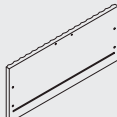
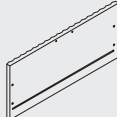
- 17  x1
- 18  x1
- 19  x1

- A  x12

Note:

Step 25 / 34

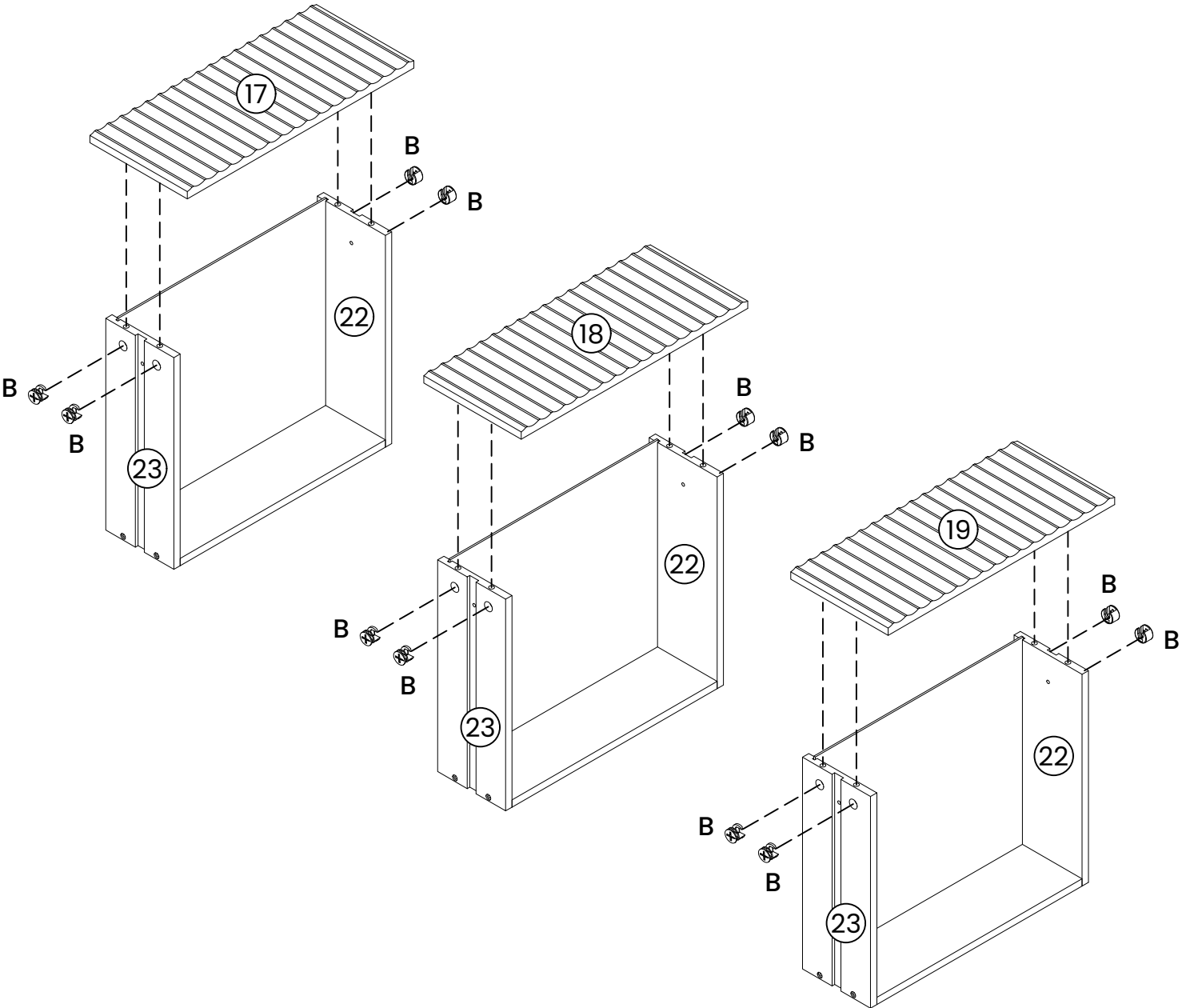

B  x12

Note:

Step 26 / 34

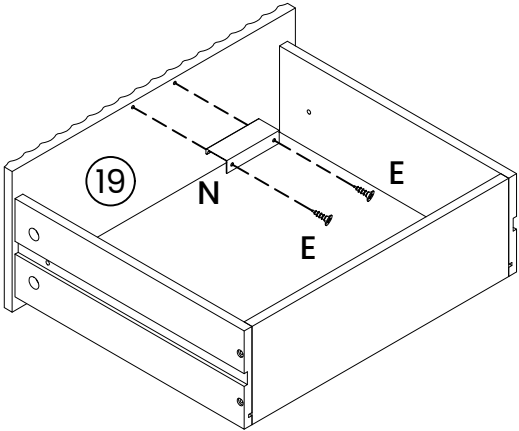
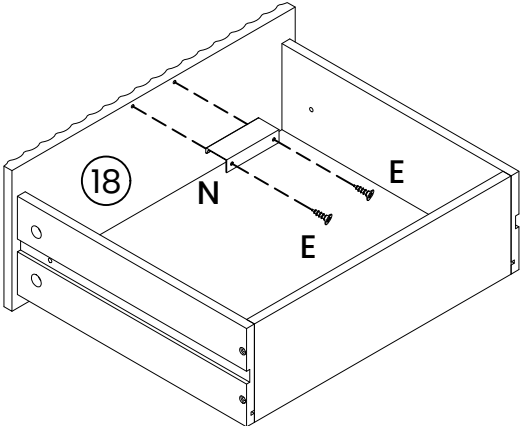
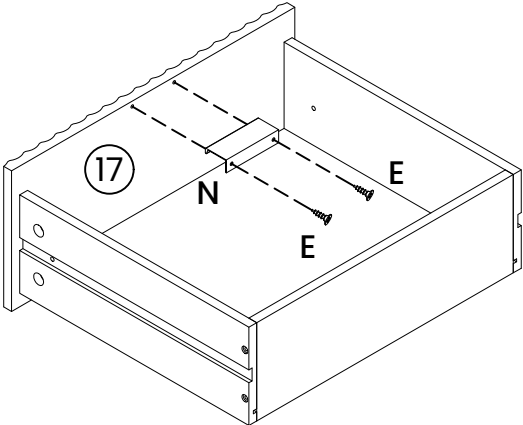

E  x6 N  x3

Note:

Step 27 / 34

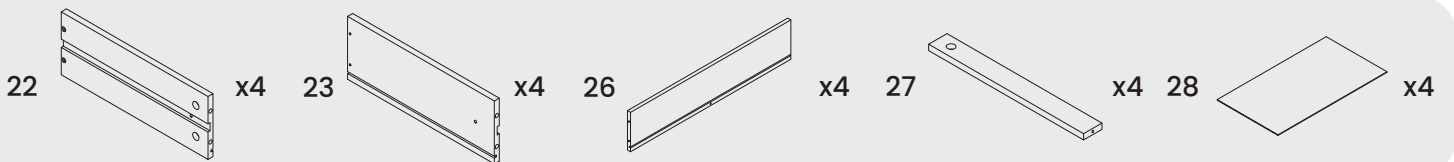
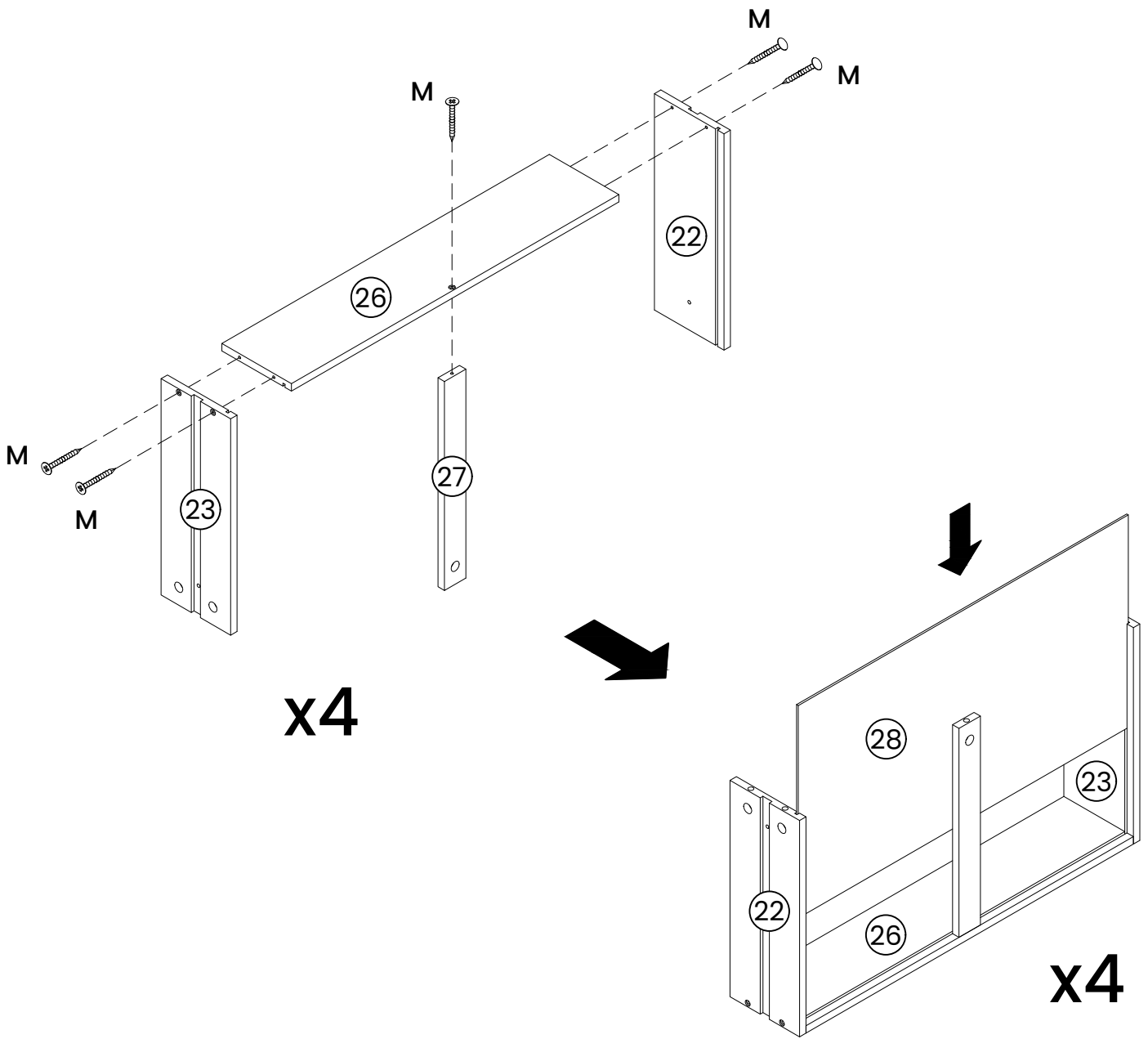

Note:

Step 28 / 34

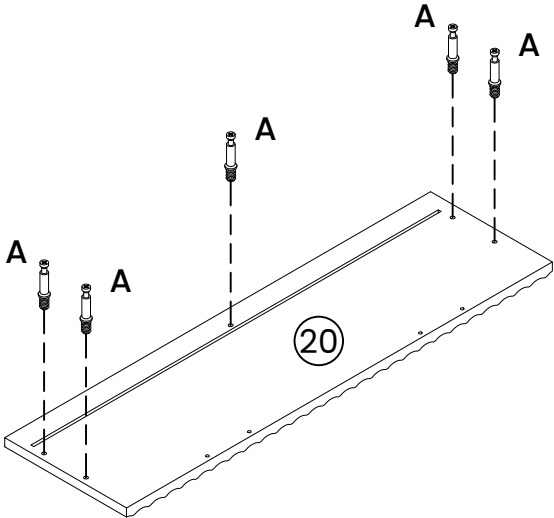

x2

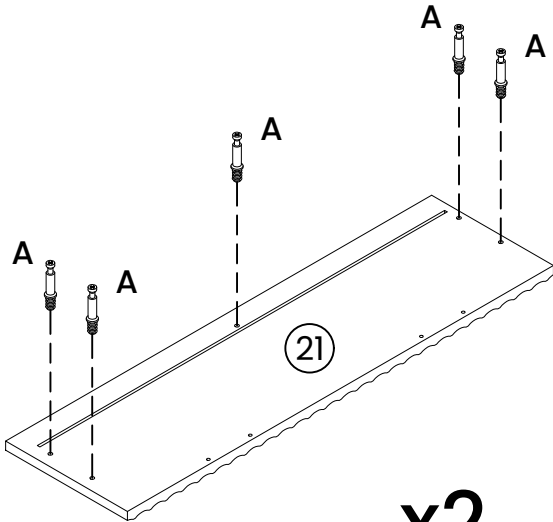

x2

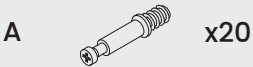

Note:

Step 29 / 34

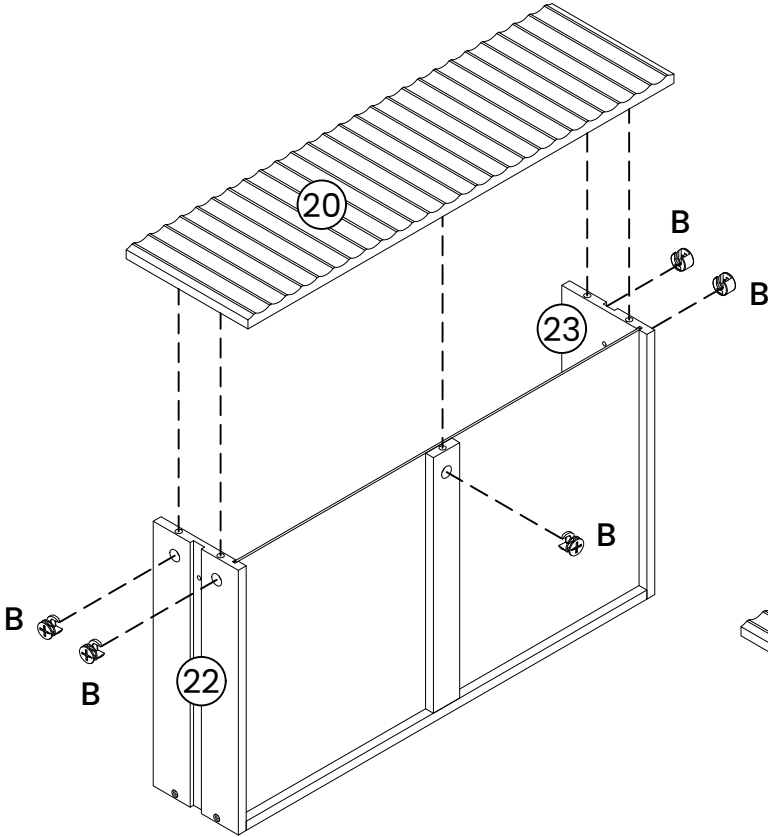

x2

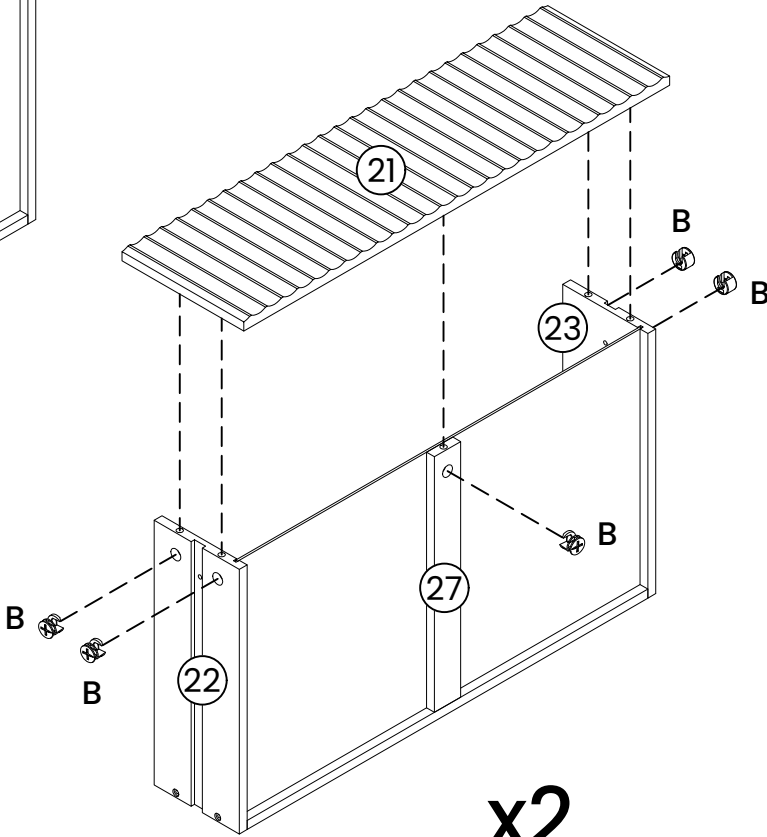

x2

B  x20

Note:

Step 30 / 34

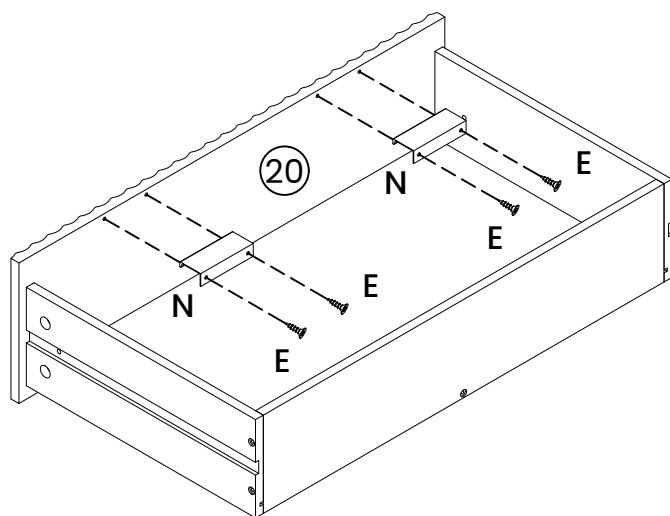

x2

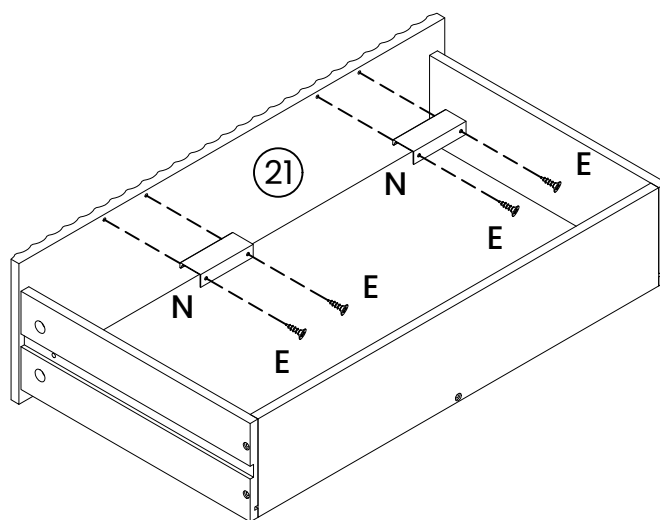

x2

E  x16

N  x8

Note:

Step 31 / 34

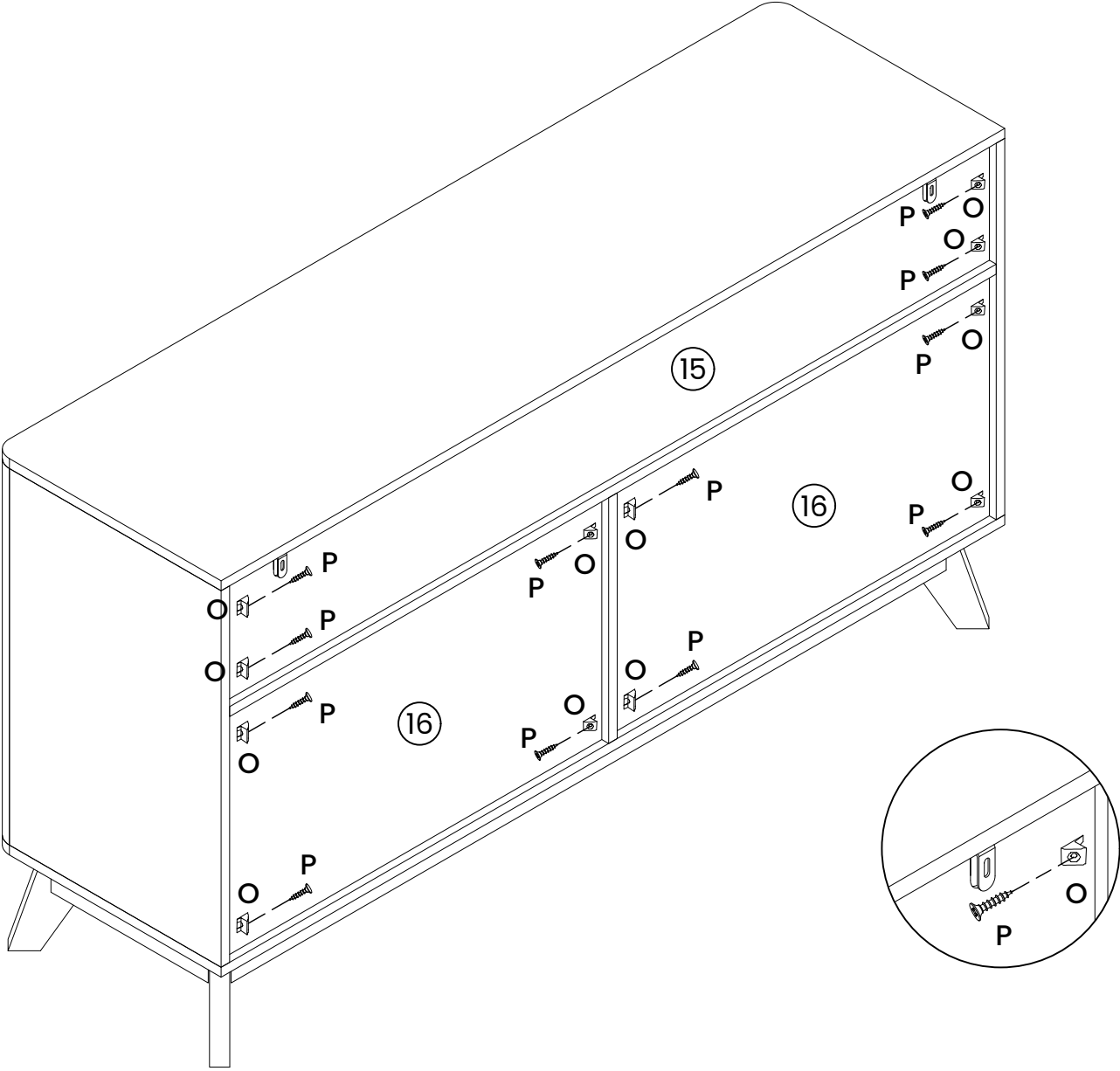



O  x12

P  x12

Note:

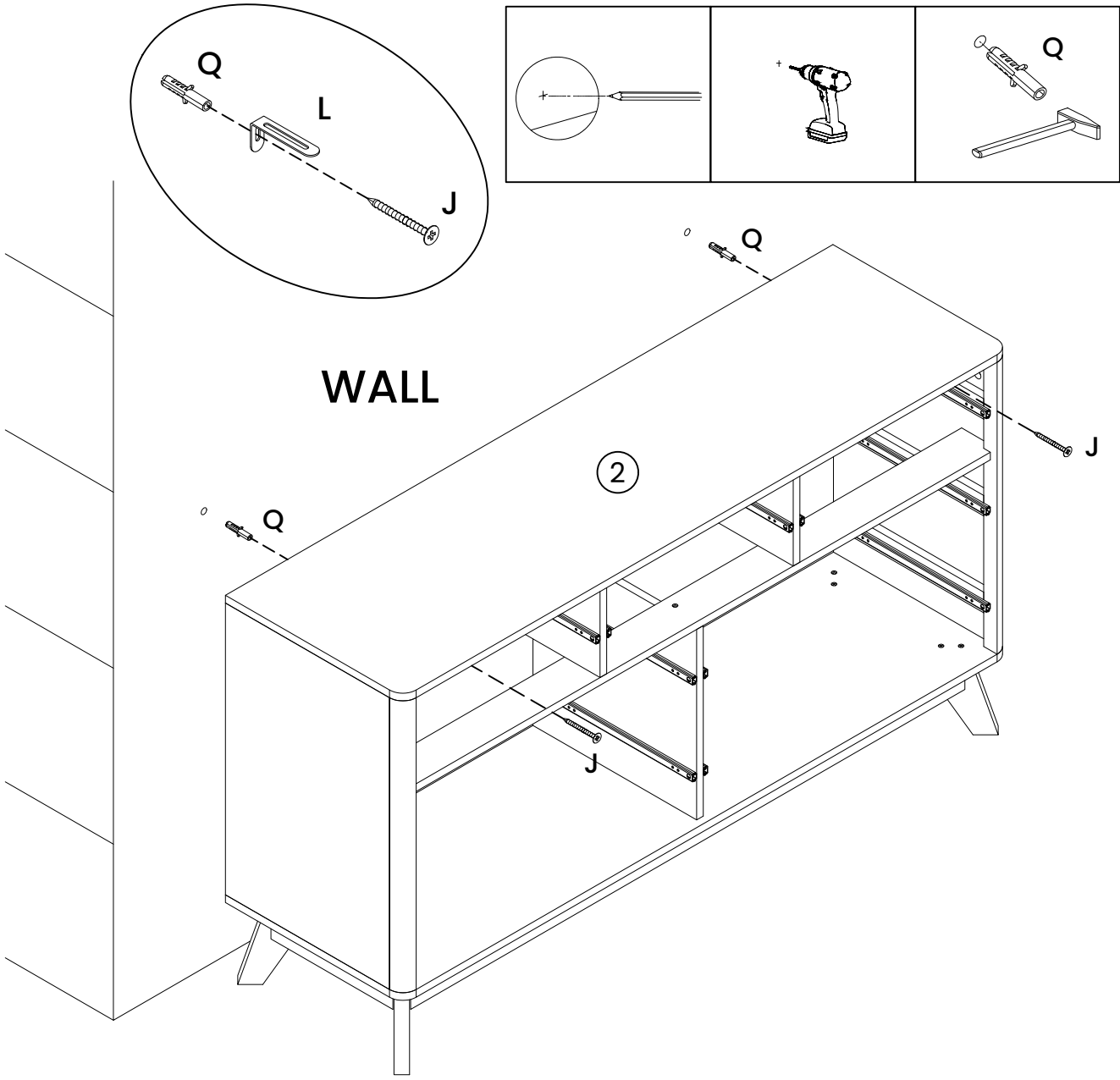
Step 32 / 34



- J  x2
- Q  x2

Note:

Step 33 / 34

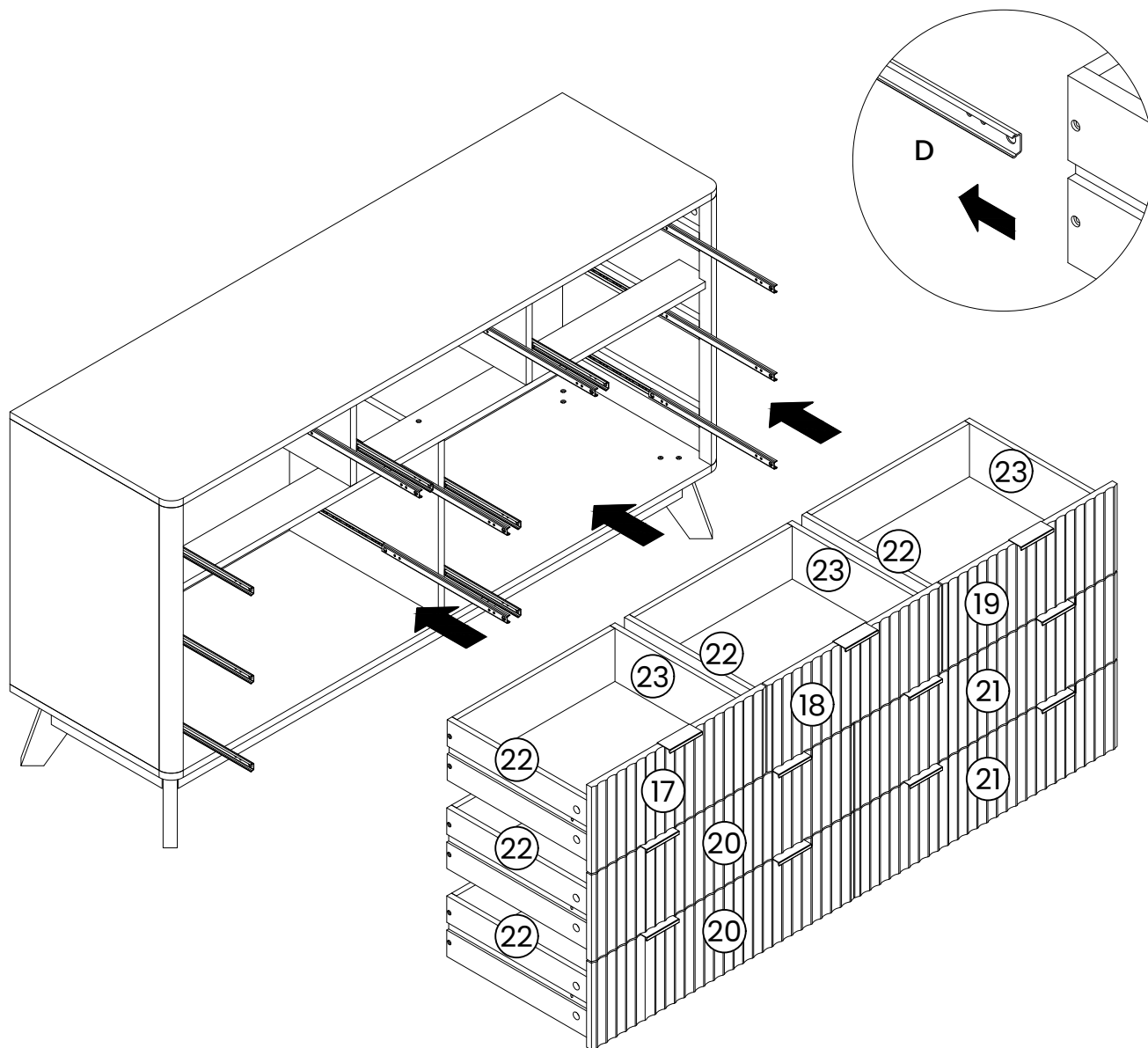

Note:

You may need patience to get a perfect smooth slide of drawer experience, and we appreciate your patience. Asking for a second person to assist you will simplify the process.

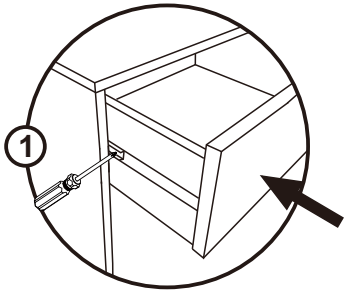

1. Align Components: Position the groove on the drawer side to match the rail profile. Insert a precision tool (e.g., screwdriver tip) into the outermost hole of the slide rail. Ensure both sides are aligned symmetrically.

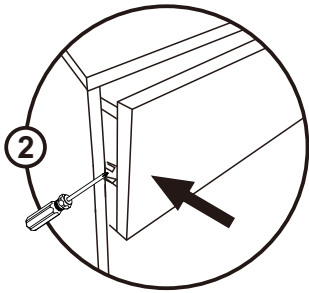

2. Slide Drawer Inward: Gently push the drawer into the cabinet until slide come up against drawer front. This step needs to be done simultaneously for both sides.

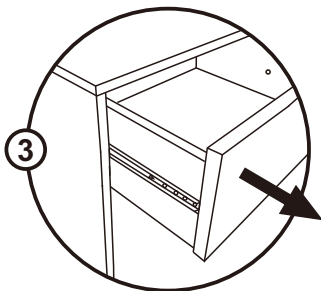

3. Secure & Adjust: While maintaining pressure on the tool, slowly pull the drawer outward until slide can not be moved.

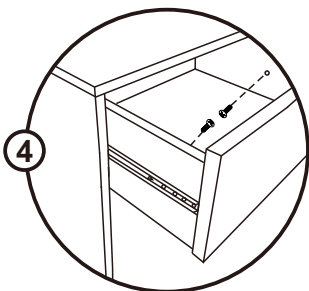

4. Finalize Installation: Locate the pre-drilled mounting holes where the rails meet the drawer sides. Securely tighten all screws on both sides.

Step 34 / 34

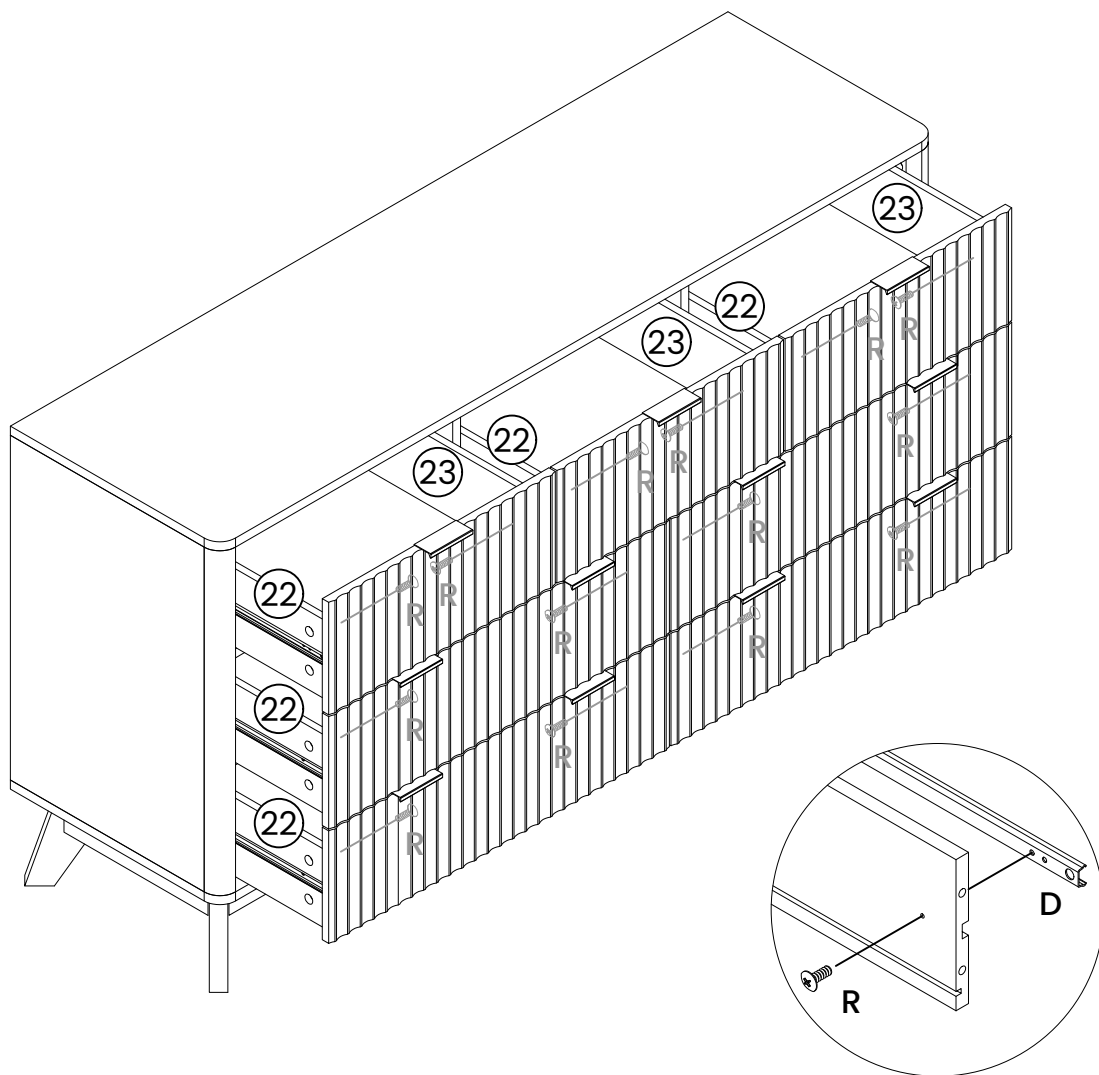

R  x14

Note:

Screw R needed to be installed from inside of the drawer to outside.