

ASSEMBLY INSTRUCTIONS



BOOKCASE

ASSEMBLY INSTRUCTIONS

ASSEMBLY TIPS:

1. Remove hardware from box and sort by size.
2. Please check to see that all hardware and parts are present prior to start of assembly.
3. Please follow attached instructions in the same sequence as numbered to assure fast & easy assembly.



WARNING!

1. Don't attempt to repair or modify parts that are broken or defective. Please contact the store immediately.
2. This product is for home use only and not intended for commercial establishments.



ASSEMBLY TIME

70 MINUTES



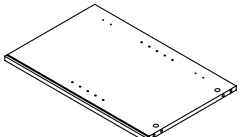
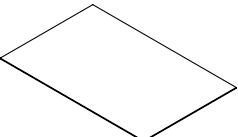
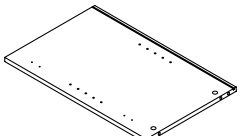
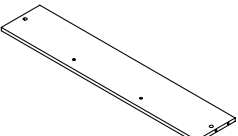
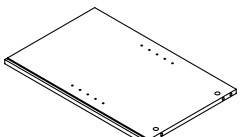
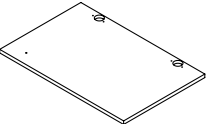
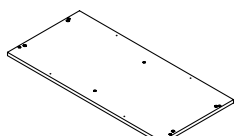
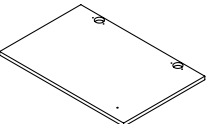
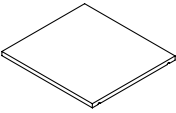
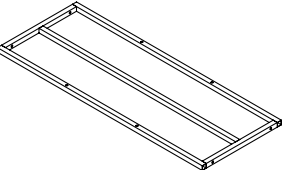
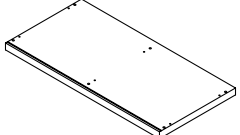
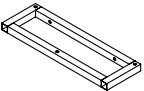
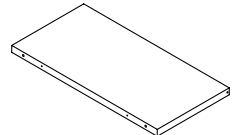
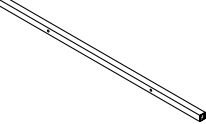
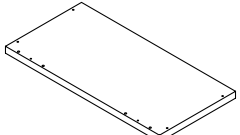
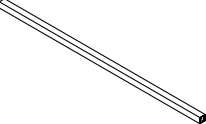





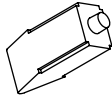
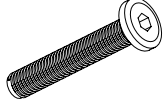
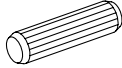
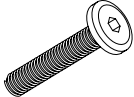
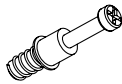
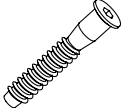

PARTS IDENTIFICATION

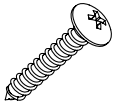
A	LOWER LEFT SIDE PANEL		1 PC	I	LOWER BACK PANEL		2 PCS
B	LOWER RIGHT SIDE PANEL		1 PC	J	UPPER BACK PANEL		2 PCS
C	MIDDLE DIVIDER PANEL		1 PC	K	LEFT DOOR		1 PC
D	BOTTOM PANEL		1 PC	L	RIGHT DOOR		1 PC
E	ADJUSTABLE SHELF		2 PCS	M	UPPER SIDE FRAME		2 PCS
F	MIDDLE CROSS PANEL		1 PC	N	LEG FRAME		2 PCS
G	UPPER CROSS PANEL		2 PCS	O	LEG FRAME TOP CROSSBAR		2 PCS
H	TOP PANEL		1 PC	P	LEG FRAME BOTTOM CROSSBAR		1 PC

NOTE:

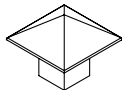
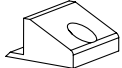
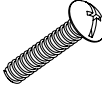
Phillips head screw driver is required in the assembly process; however, manufacturer does not provide this item.

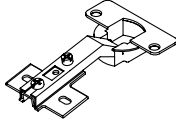
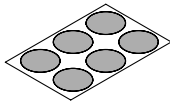
HARDWARE IDENTIFICATION

Z							
NO	DESCRIPTION	FIGURE	Q'TY	NO	DESCRIPTION	FIGURE	Q'TY
1	GLUE 40g		1 PC	11	BOLT M6x43mm BLK		6 PCS
2	WOODEN DOWEL Ø8x30mm		24 PCS	12	BOLT M6x35mm BLK		4 PCS
3	CAM BOLT Ø7x35.5mm SR		10 PCS	13	BOLT Ø7x40mm BLK		16 PCS
4	CAM LOCK Ø15x12mm SR		10 PCS	14	SCREW Ø5x35mm BLK		4 PCS
5	SCREW Ø4.5x42mm SR		10 PCS	15	FLOOR PROTECTOR 20x20mm		4 PCS
6	PIN Ø4.9x8mm SR		8 PCS	16	ALLEN WRENCH 4mm SR		1 PC
7	HANDLE BLK		2 PCS	17	FIXER		6 PCS
8	HANDLE BOLT BLK		2 PCS	18	FIXER SCREW Ø3x19mm SR		6 PCS
9	HINGE Ø35mm SR		4 PCS	19	STICKER Ø20mm		3 PCS
10	HINGE SCREW Ø4x15mm SR		16 PCS				

Z9 not included in blister packaging.

NOTE:

Phillips head screw driver is required in the assembly process; however, manufacturer does not provide this item.

STEP 1

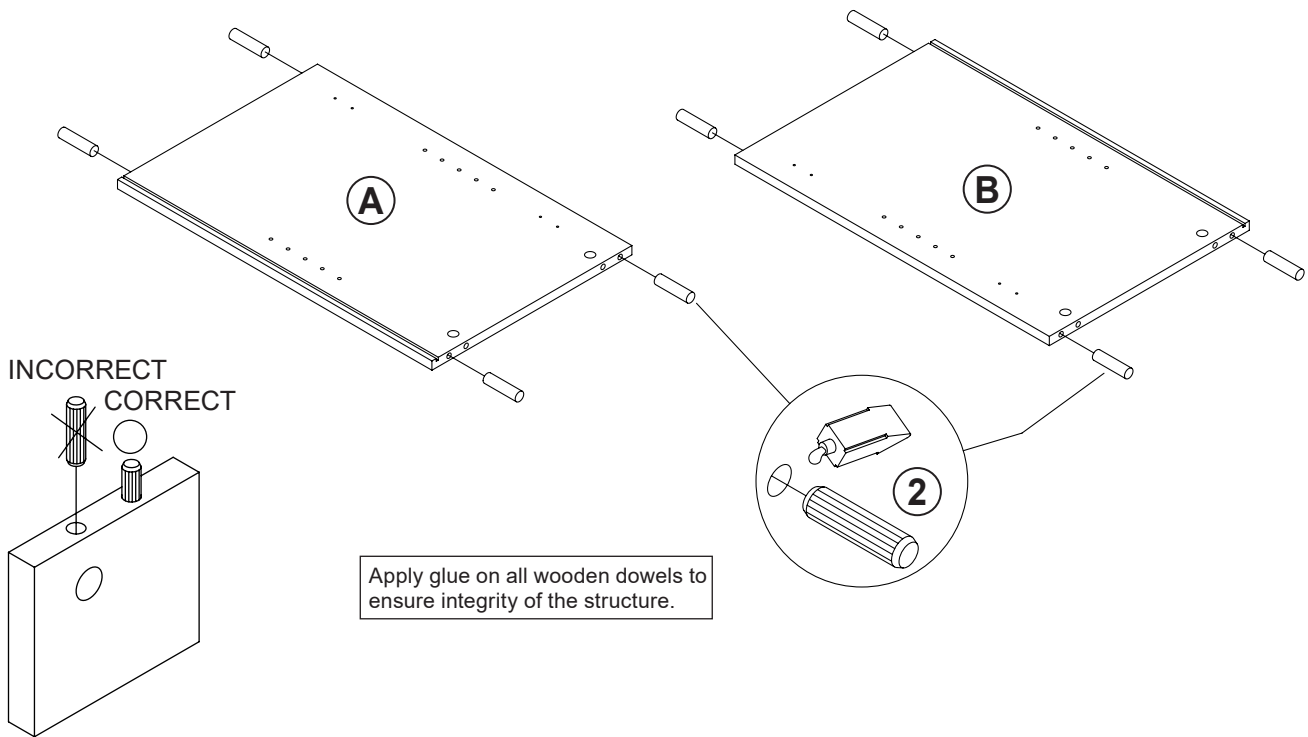
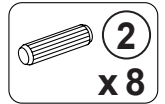

STEP 2

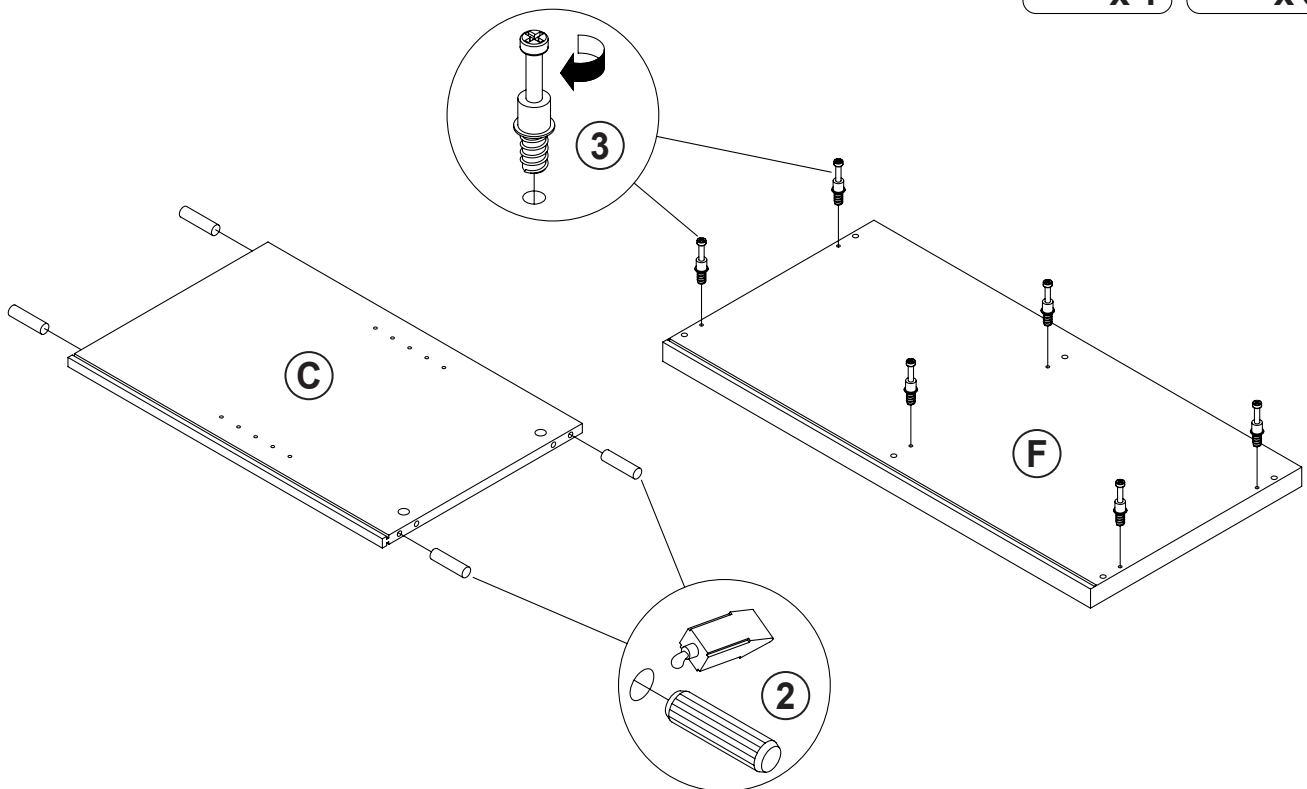
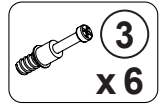
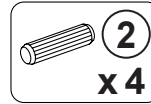

STEP 3

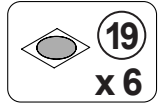
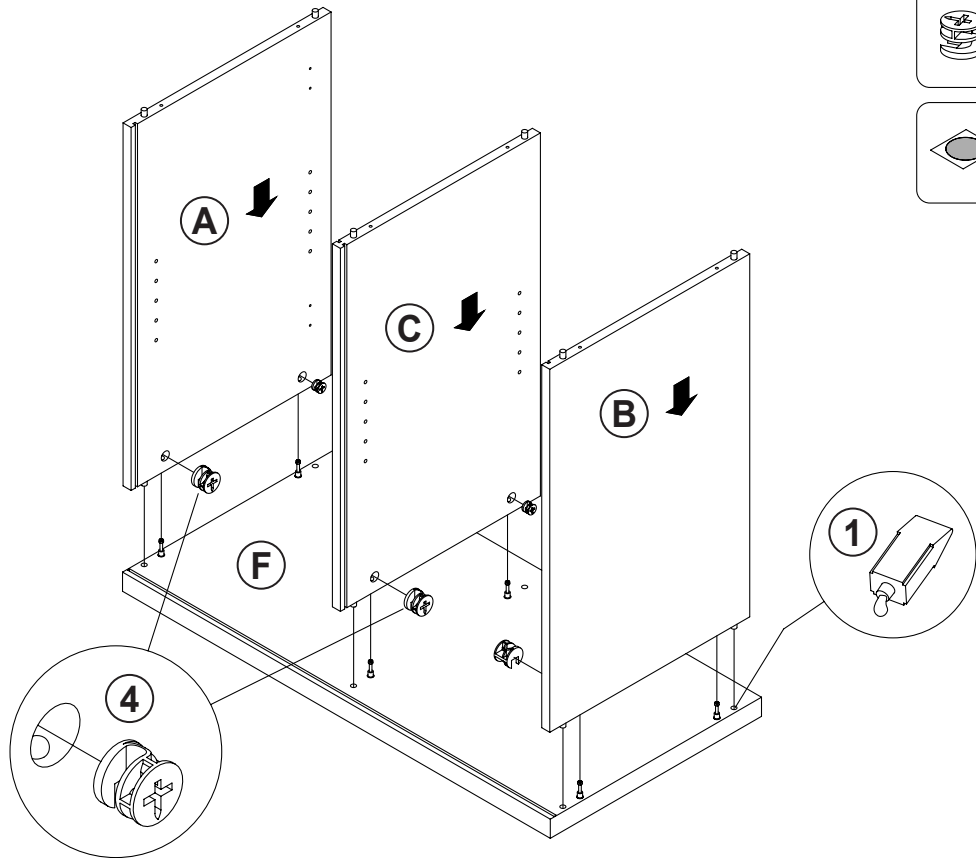
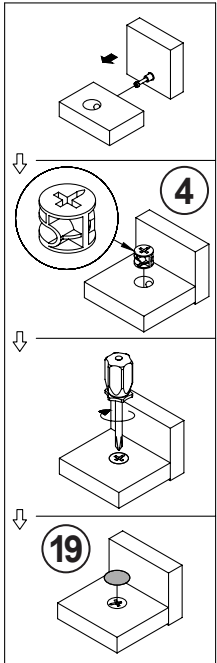

STEP 4

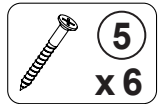

Apply glue on all wooden dowels to ensure integrity of the structure.

STEP 5

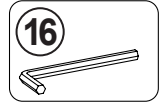
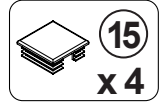
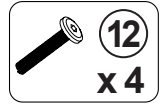
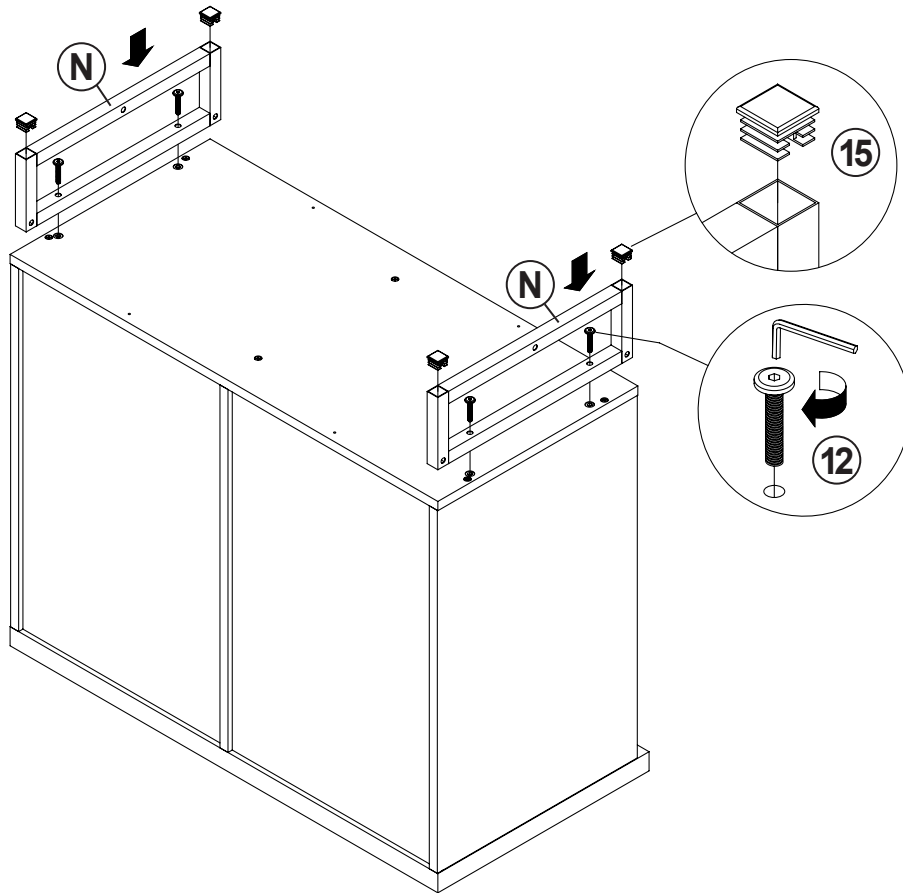

STEP 6

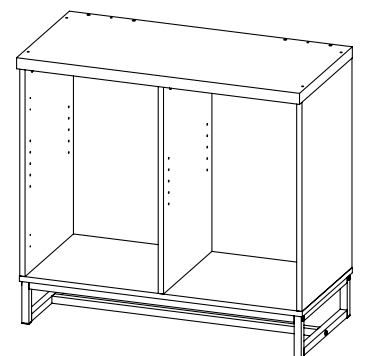
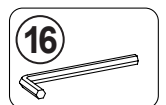
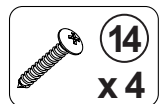
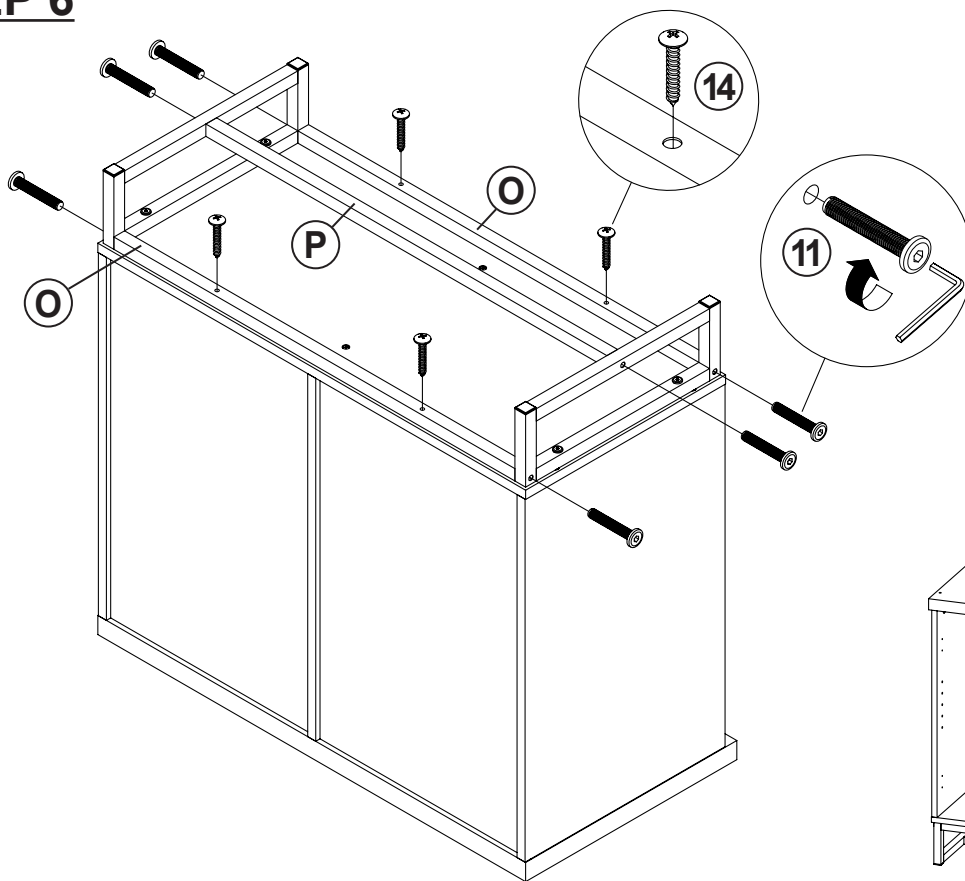

STEP 7

2
x 12

3
x 2

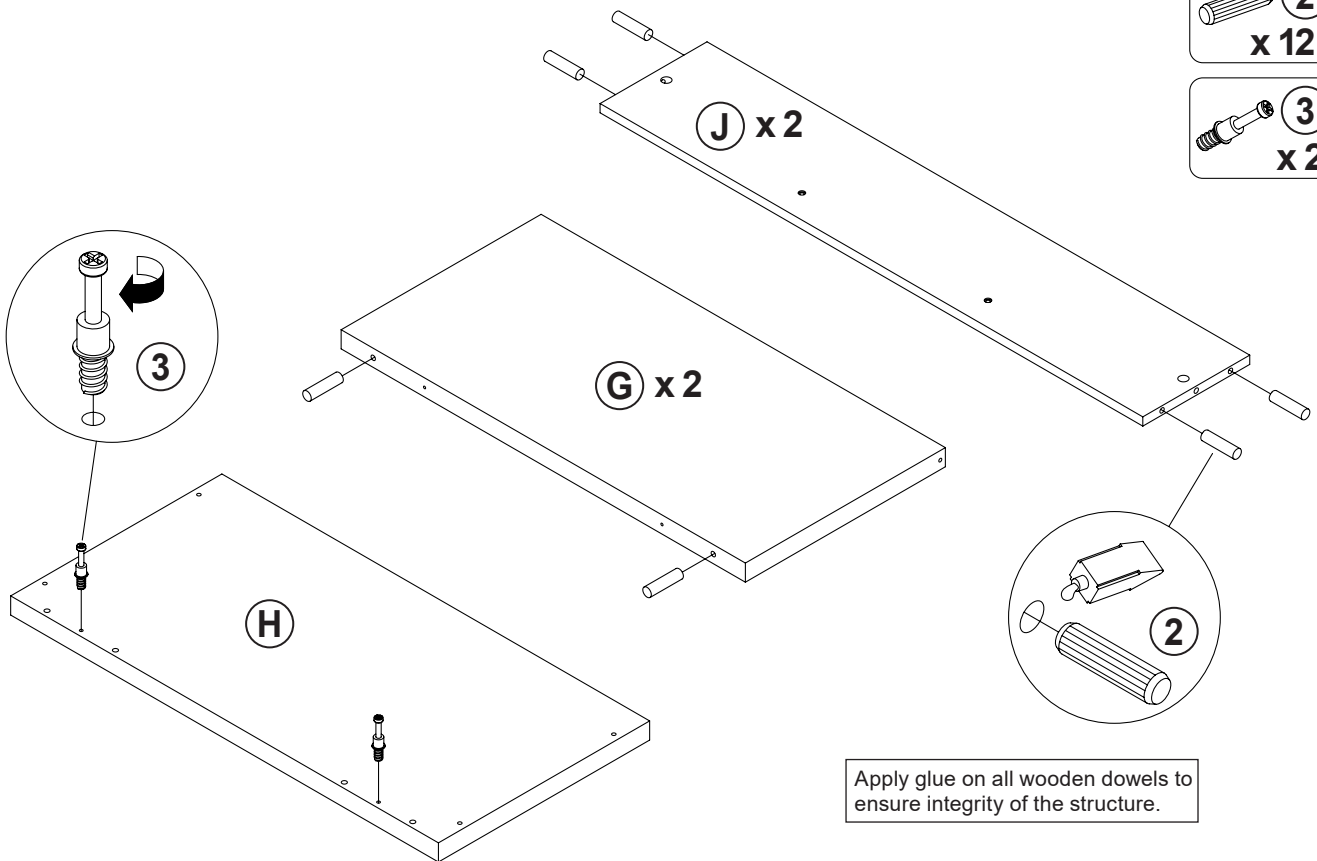

Apply glue on all wooden dowels to ensure integrity of the structure.

STEP 8

3
x 2

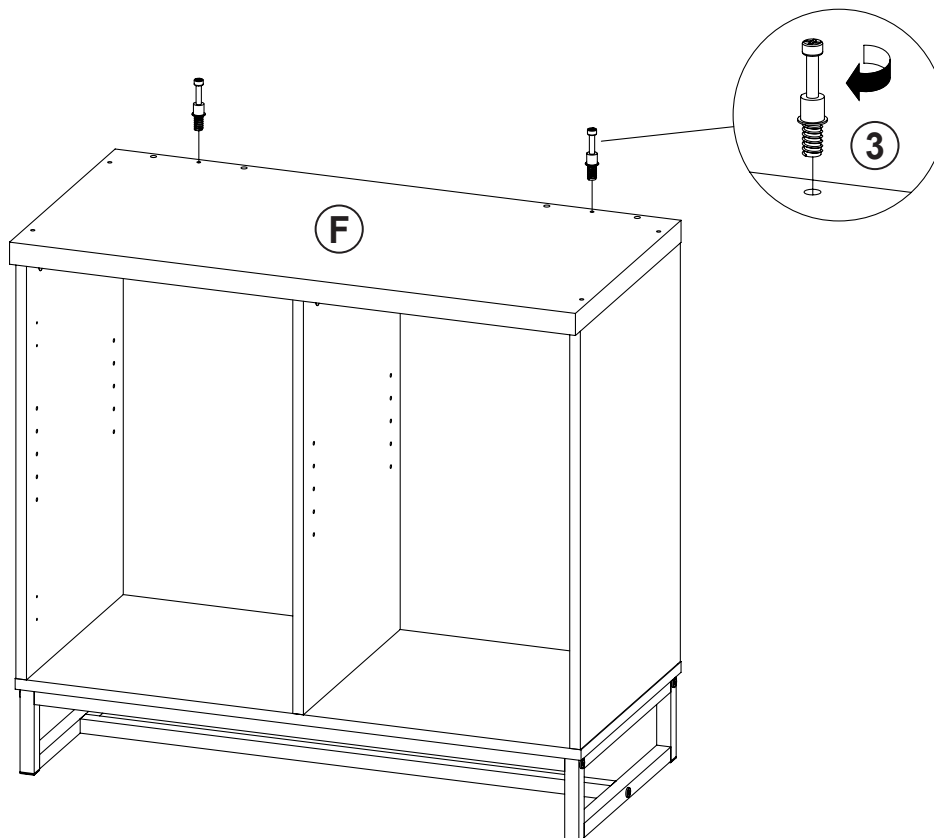

STEP 9

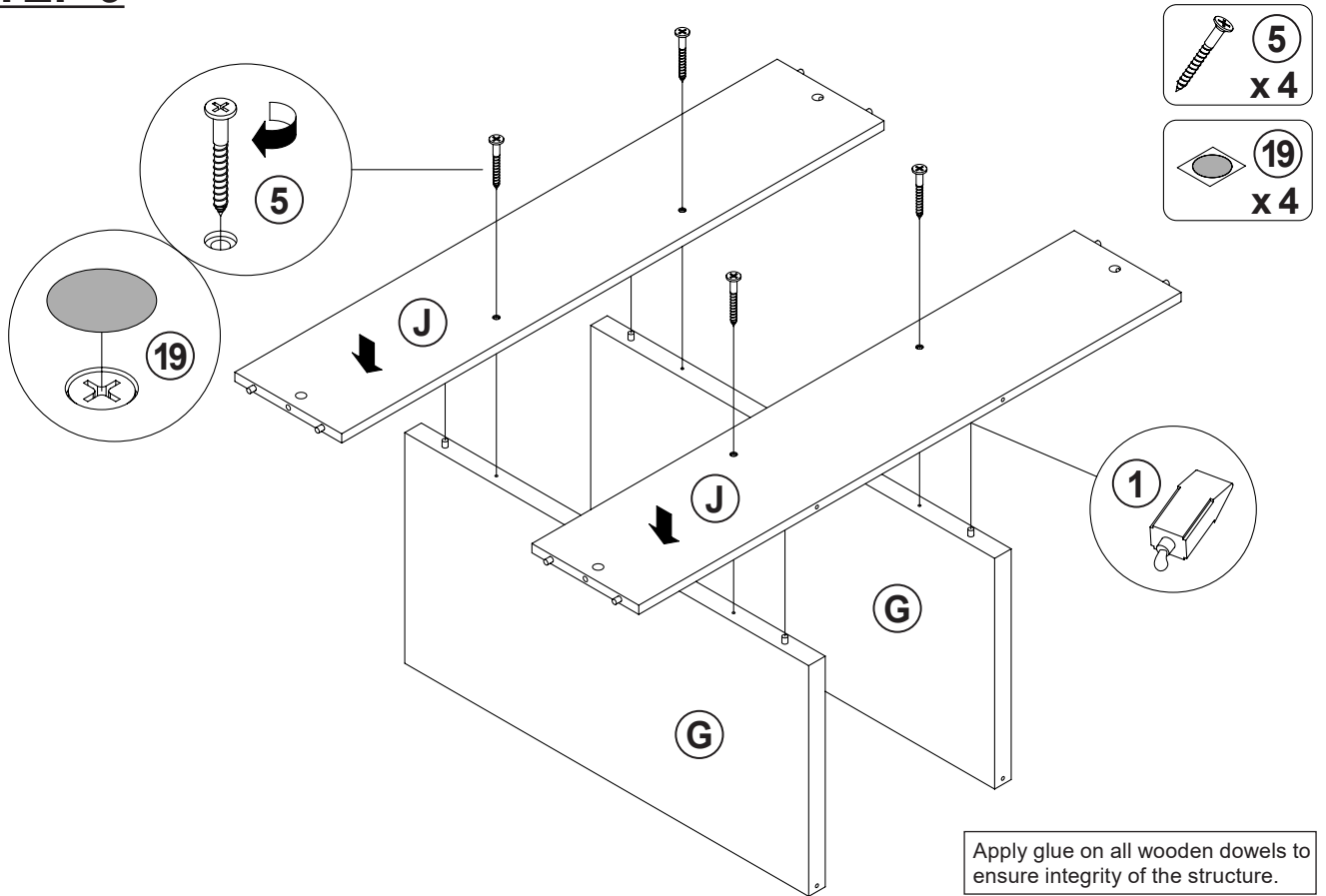

STEP 10

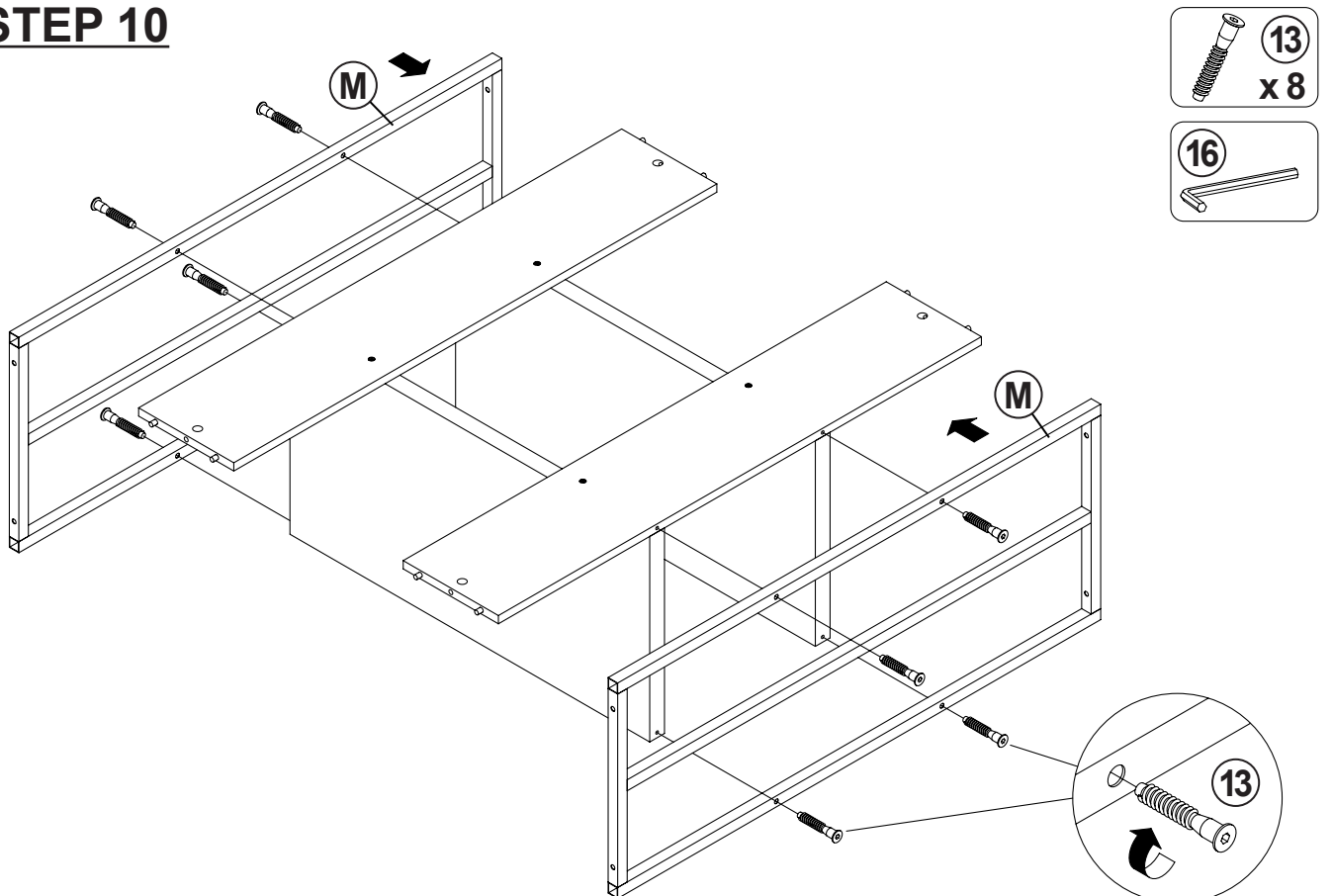

STEP 11

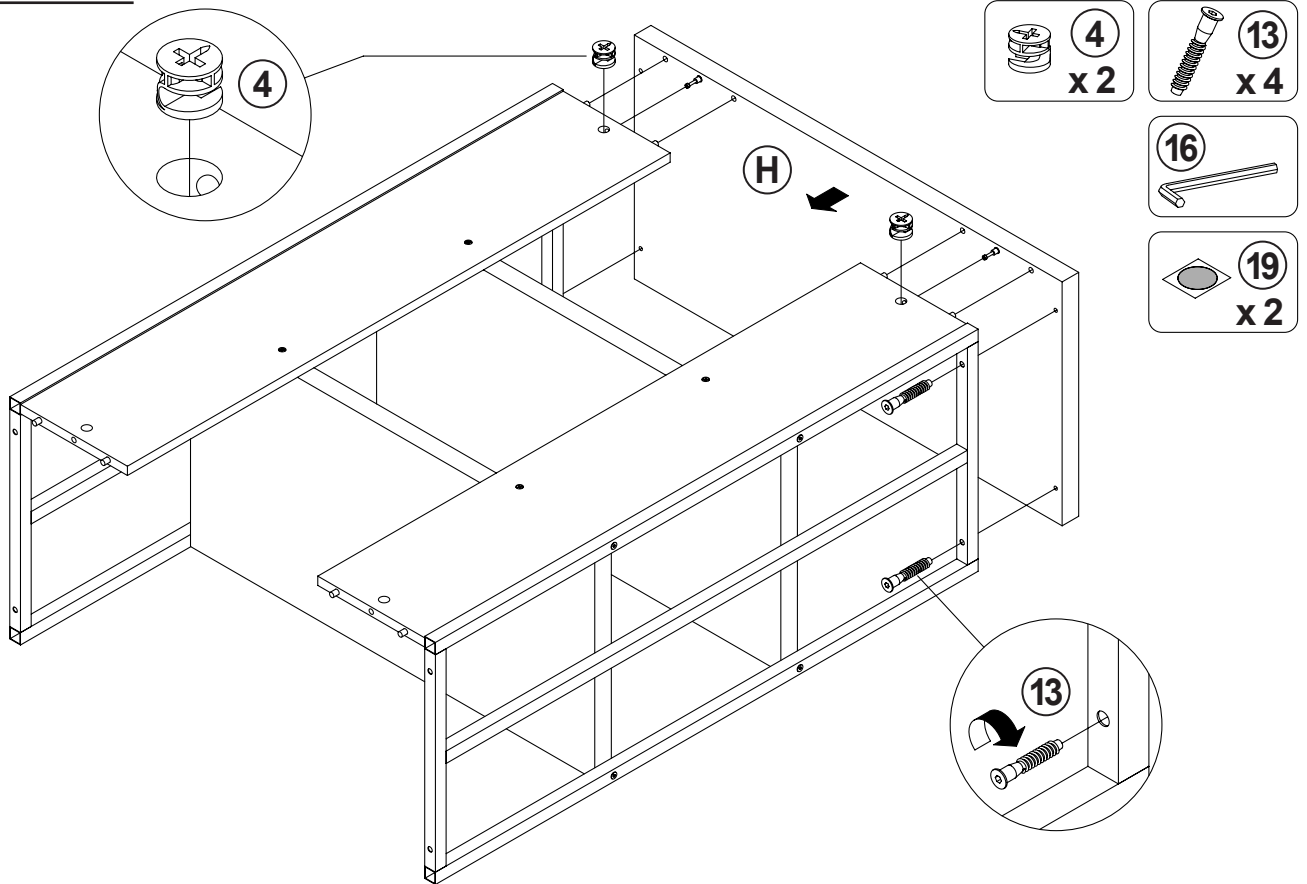

STEP 12

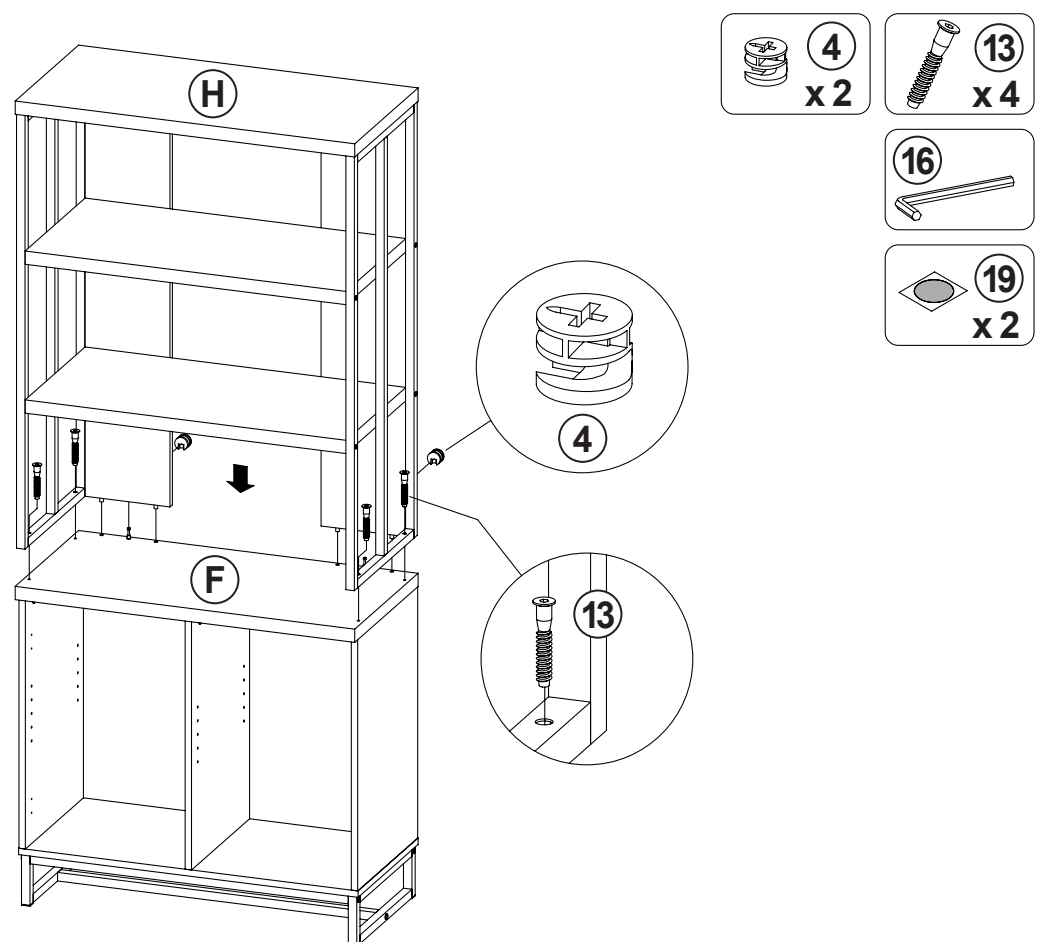

STEP 13

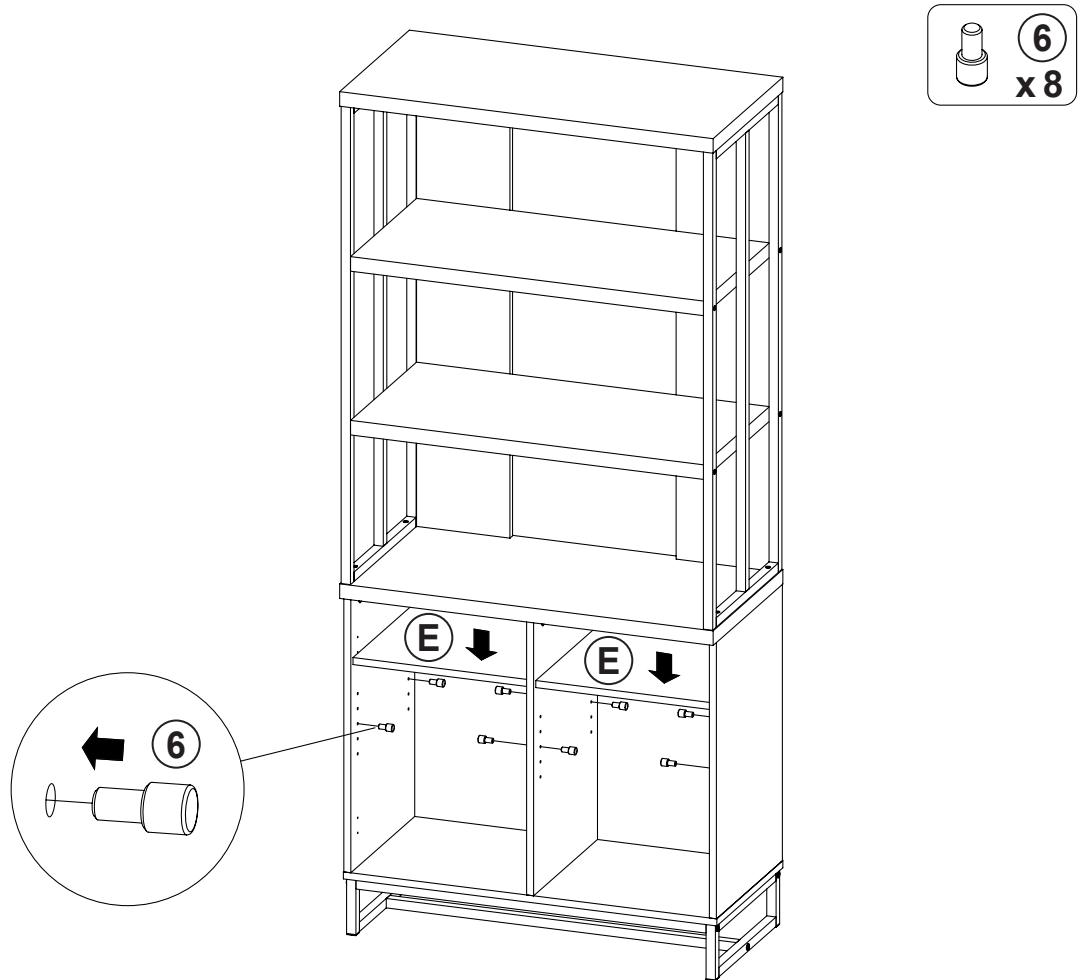

STEP 14

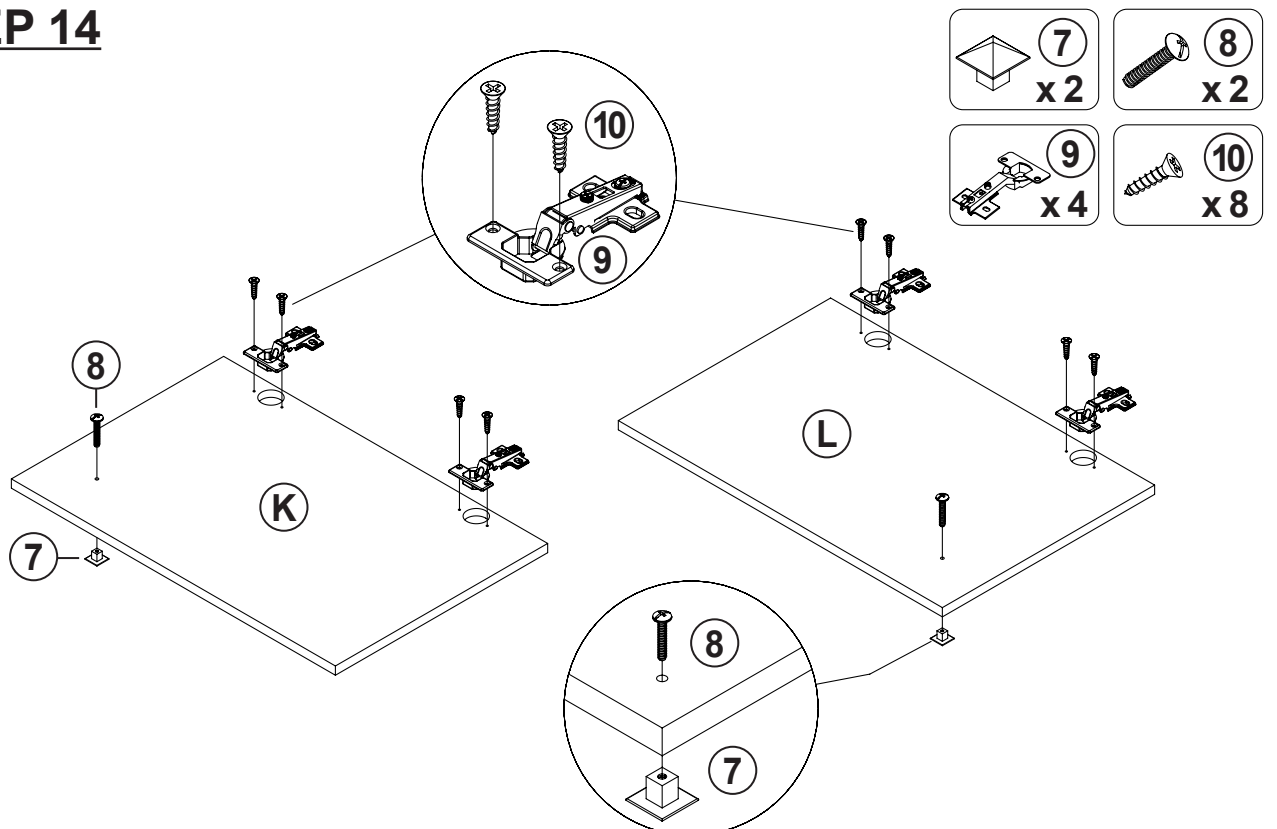

STEP 15

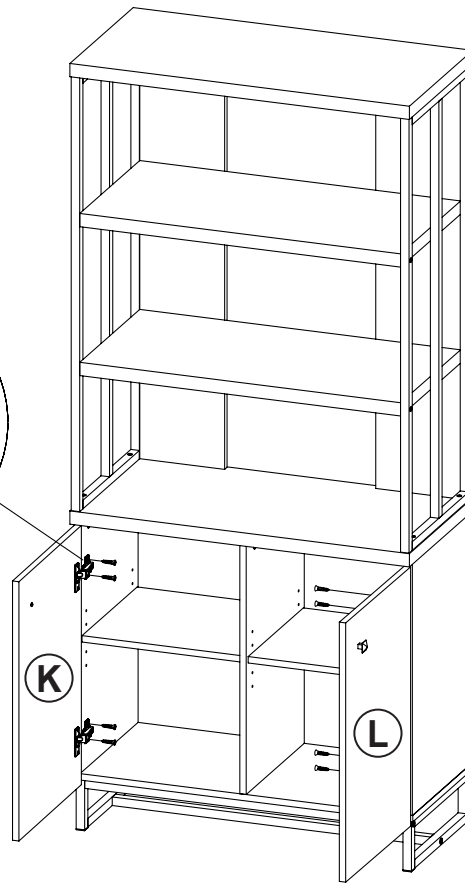
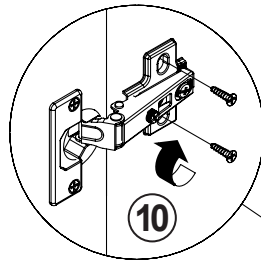
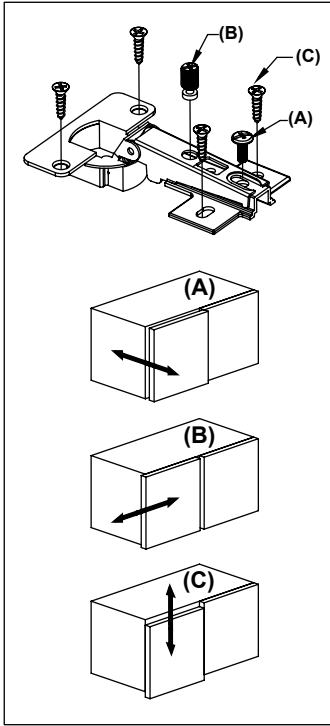
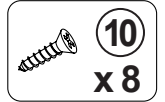

STEP 16

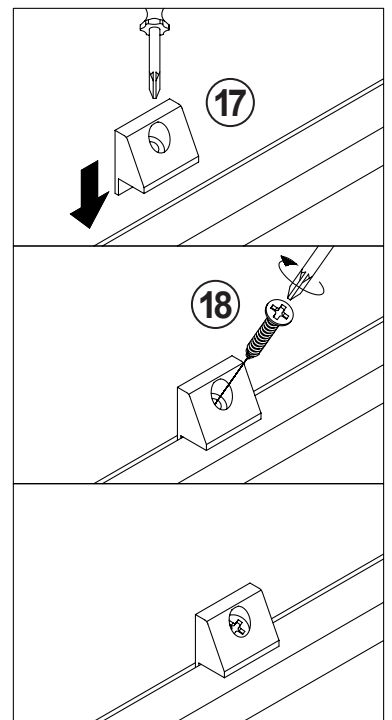
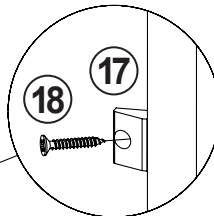
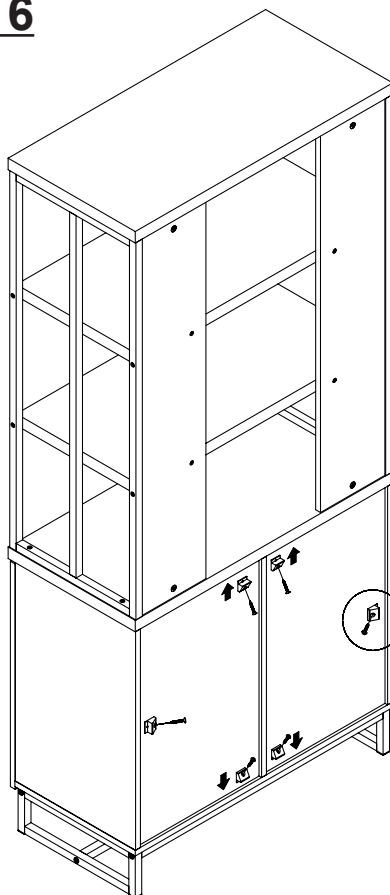
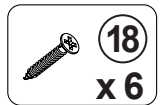
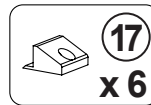

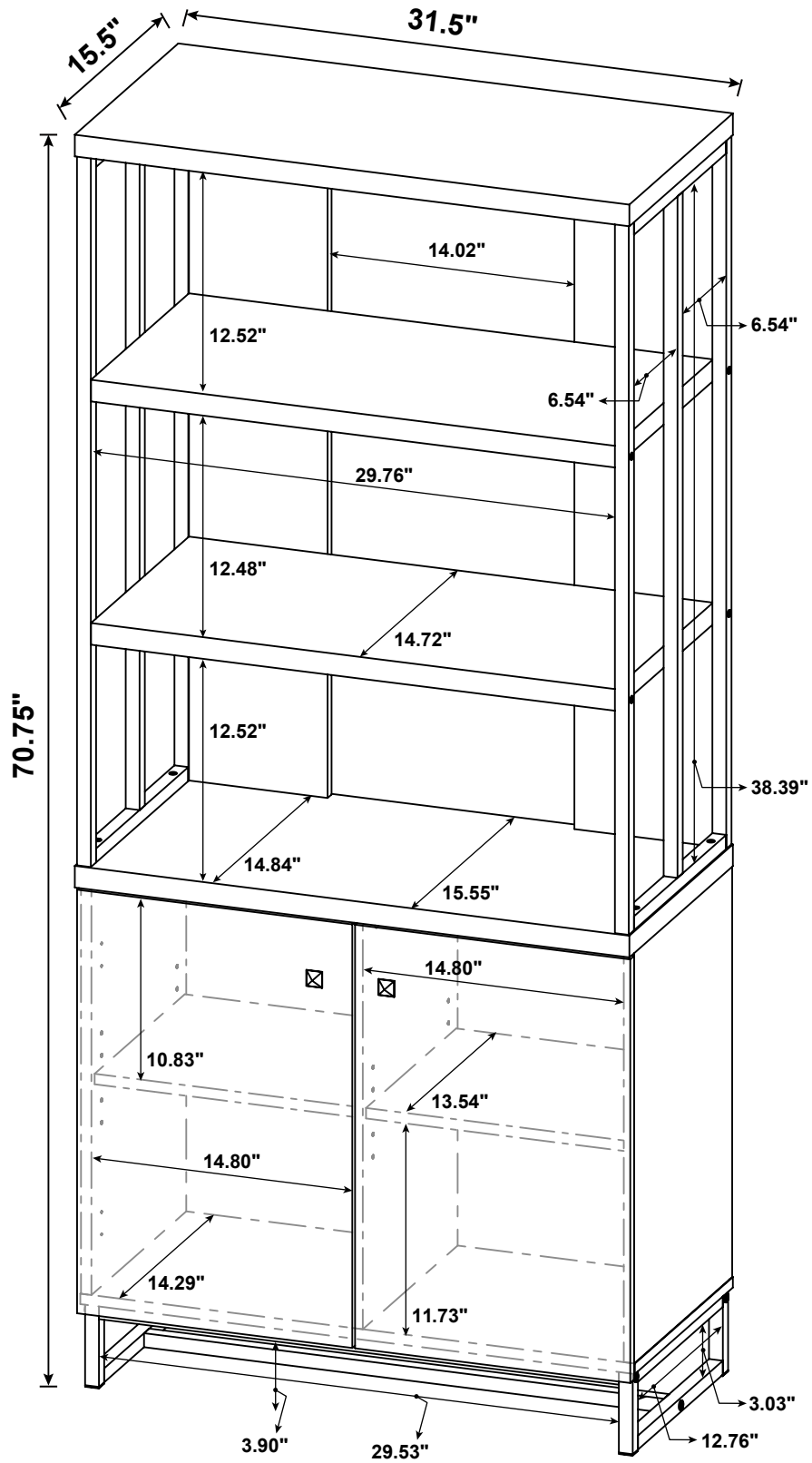

Note : Dimension tolerance $\pm 5\%$

ANTI-TIPPING INSTALLMENT INSTRUCTIONS

FURNITURE TIPPING RESTRAINT

WARNING

Injury may result from tipping furniture.
This restraint may protect against tipping furniture.
Do not allow children to climb on furniture.
This restraint is not a substitute for proper adult supervision.
Failure to detach this restraint before moving the furniture may result in injury and damage.

This restraint must be screwed to a wood stud on the wall, using the long screw provided.

STEP 1

Secure the bracket to the back top of the unit, using the short screw provided, as shown in the drawing.

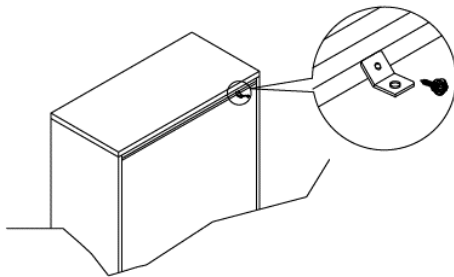

STEP 2

Locate the wood stud on the wall, and secure the other bracket, 2 inches below the back of the unit.

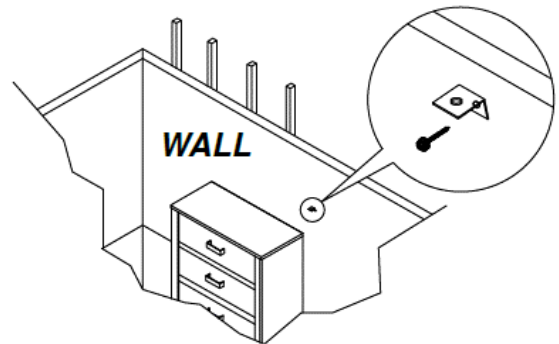

STEP 3

Place the furniture into position so both mounting brackets are vertically in line. Lace the end of the restraint strap through the larger hole in each mounting bracket. Bring both ends together and slide the flat end through the locking end, and drag it through, until the slack is removed. Ensure that the strap is securely laced and locked.

