

Assembly Instructions

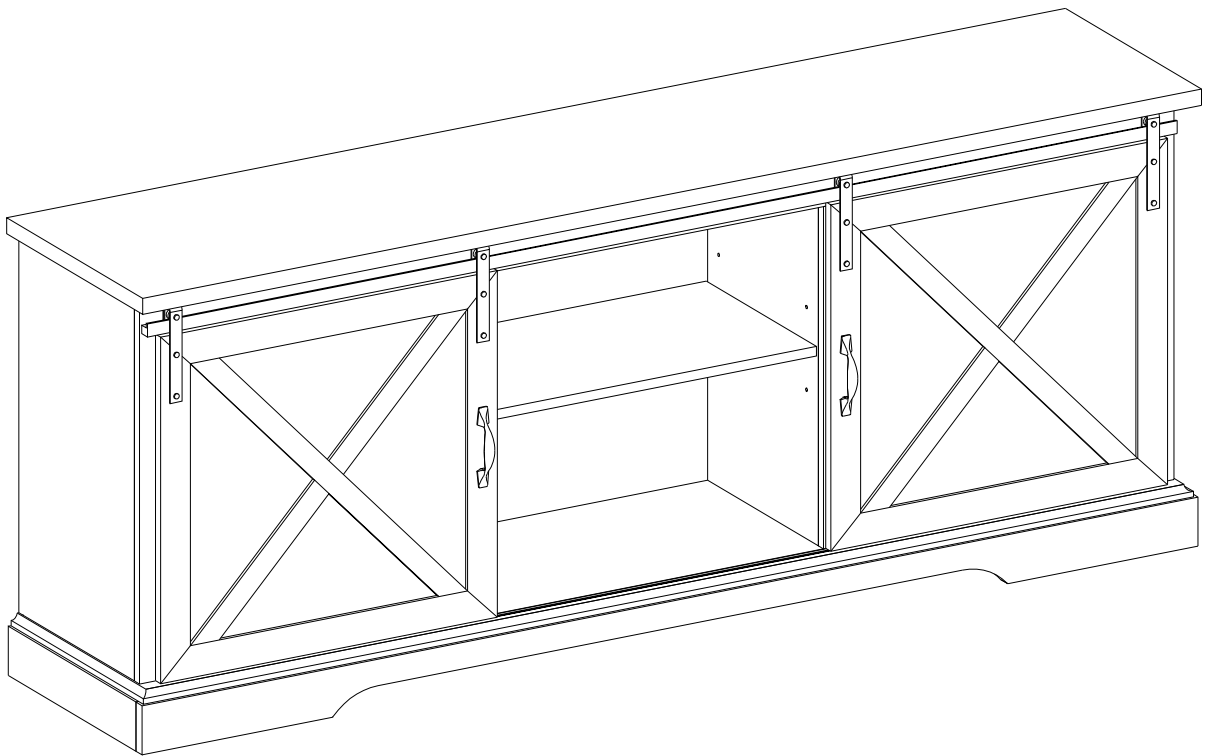

General Assembly Guidelines

- I. Ensure that all parts and hardware are available before beginning assembly.
- II. Follow each step carefully to ensure the proper assembly of this product.
- III. Two people are recommended for ease in the assembly of this product.
- IV. The three main types of hardware used to assemble this product are : wood dowels , screws and bolts.
- V. The provided glue is to secure wood dowels in place . When first inserting dowels , locate the appropriate hole for the dowel , place a small amount of glue in the hole and insert the dowel . Wipe away excess glue immediately.

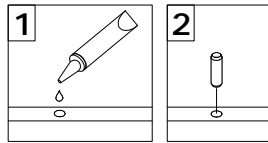

In future assembly steps when dowels are necessary to attach assembly parts together , place a small amount of glue on the end of the dowel before attaching parts together . Wipe away excess glue immediately.

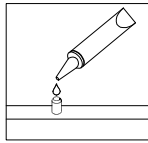

- VI. A Phillips head screwdriver is required for the assembly of this product .

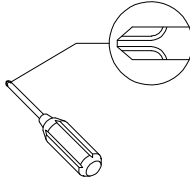



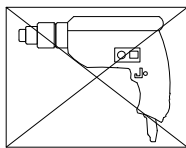



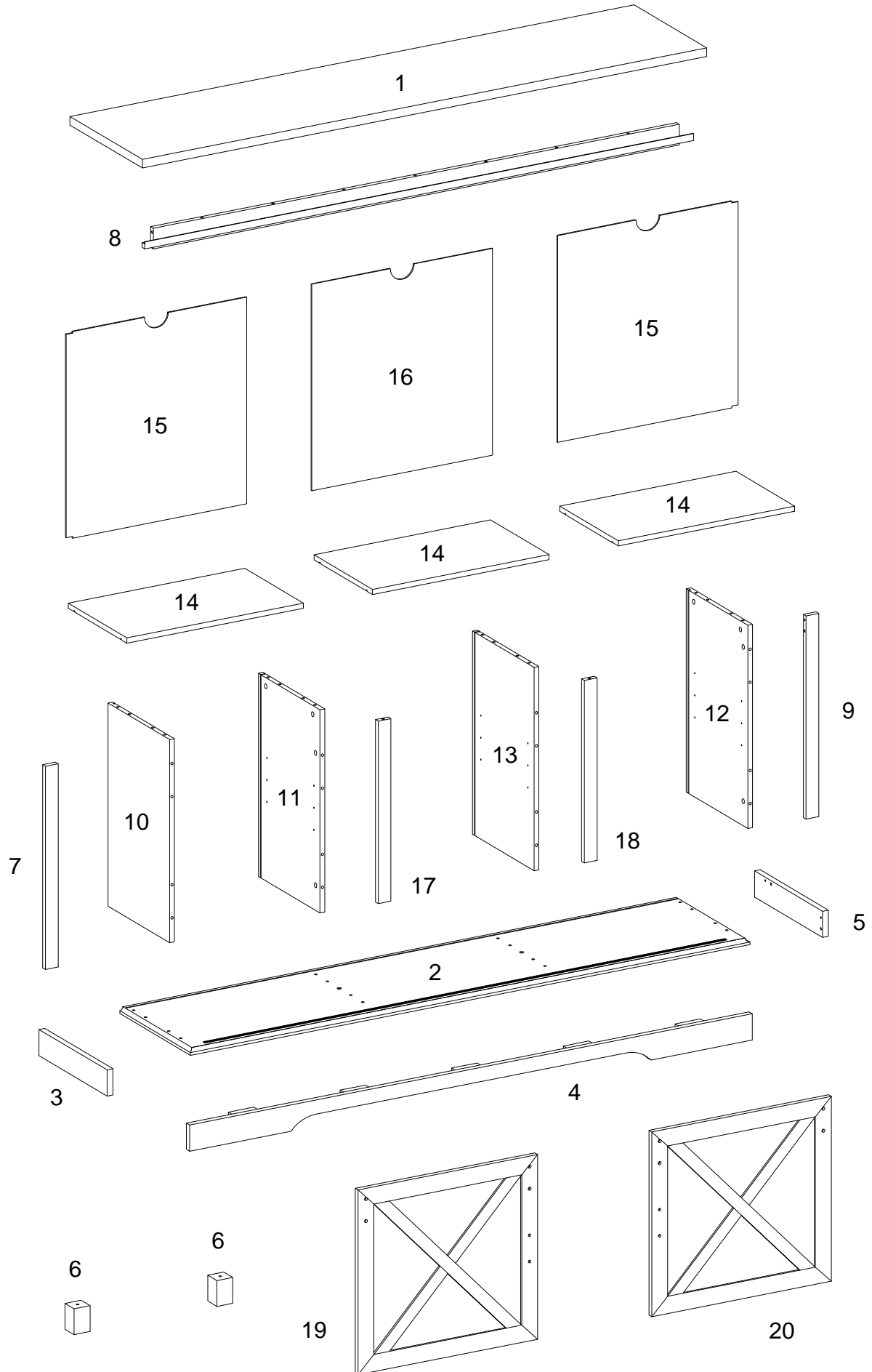



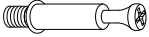

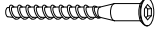

- VII. Power tools should not be used to assemble this product .



Parts List

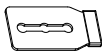
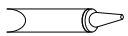

Hardware List

A		Ø8x30mm	Wooden dowel	31	pcs
B		Ø6x35mm	Cam bolt	22	pcs
C		Ø15x11mm	Cam lock	22	pcs
D		Ø30mm	Sticker	22	pcs
E		M 4	Hex key	1	pc
F		Ø6x50mm	Bolt	10	pcs
G		Ø6x12mm	Bolt	18	pcs
H		56x27x27mm	Connector	9	pcs
J		Ø1/4x13mm	Bolt	8	pcs
K			Pulley	4	pcs
L			Handle	2	pcs
M		Ø4x12mm	Handle Bolt	4	pcs
N		Ø3x17mm	Screw	12	pcs
P			Plastic wedge	12	pcs
Q			Shelf support pin	12	pcs
R		Ø4x12mm	Screw	8	pcs
S			Plate	4	pcs
T			Glue tube	1	pc

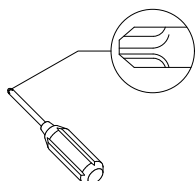

Philips head screwdriver required for assembly
(not included)

*The hardware quantities listed above are required for proper assembly.
Some extra hardware may also have been included.*

Step 1

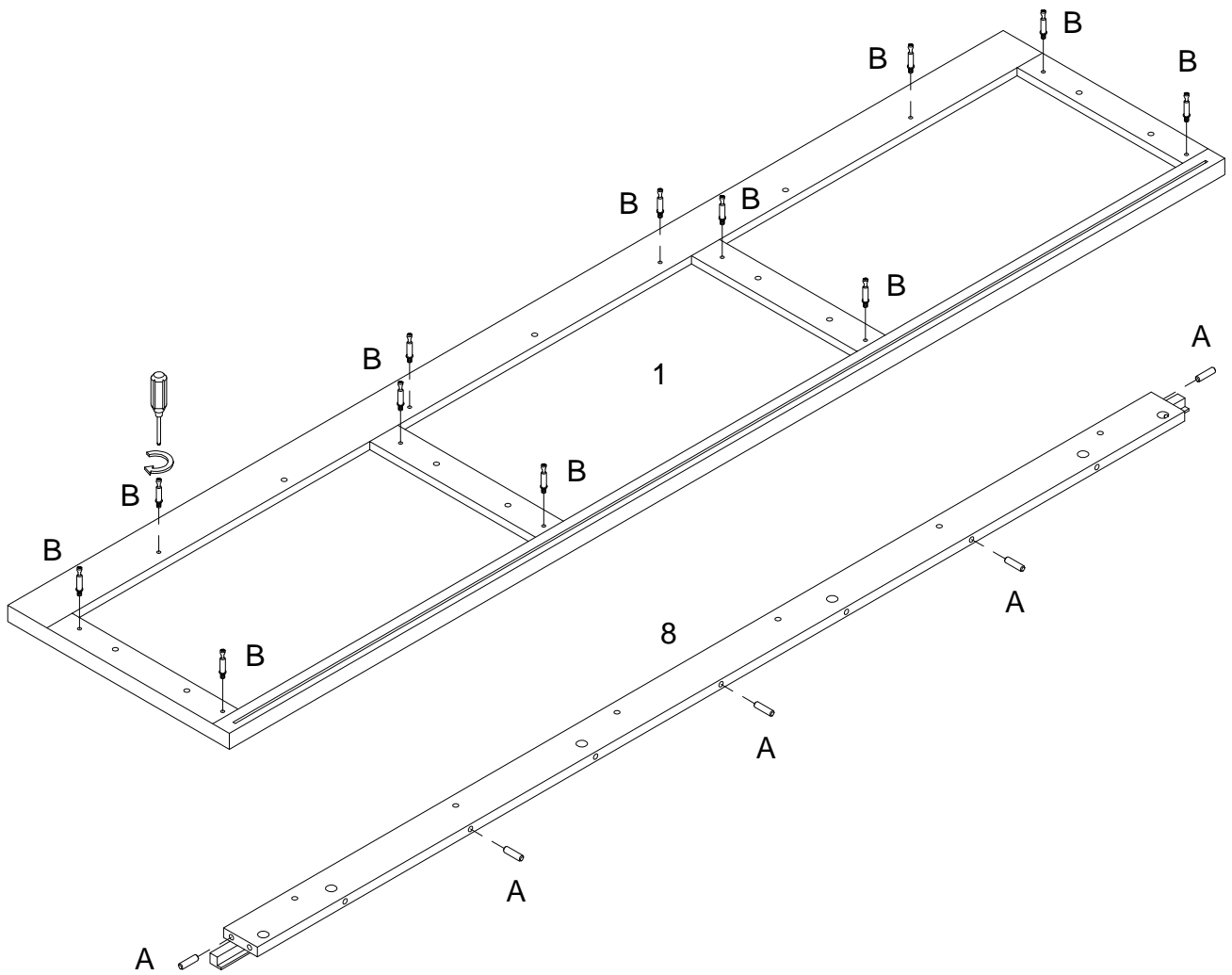

Insert wooden dowel (A) into part (8) , then secure cam bolt (B) into part (1) with Philips head screwdriver as per diagram.

Step 2

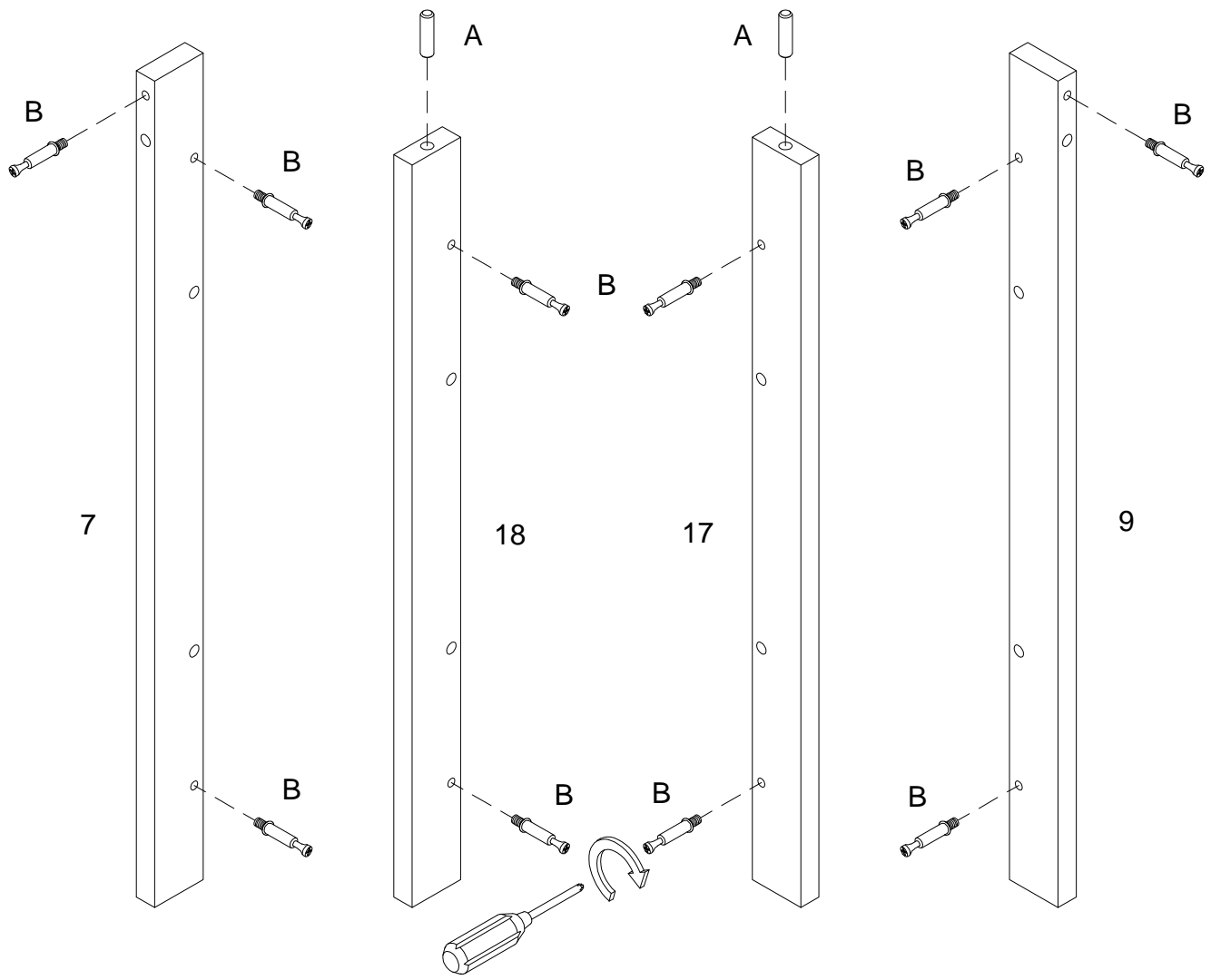

Insert wooden dowel (A) into parts (17,18) , then secure cam bolt (B) into parts (7,9,17,18) with Philips head screwdriver as per diagram.

Step 3

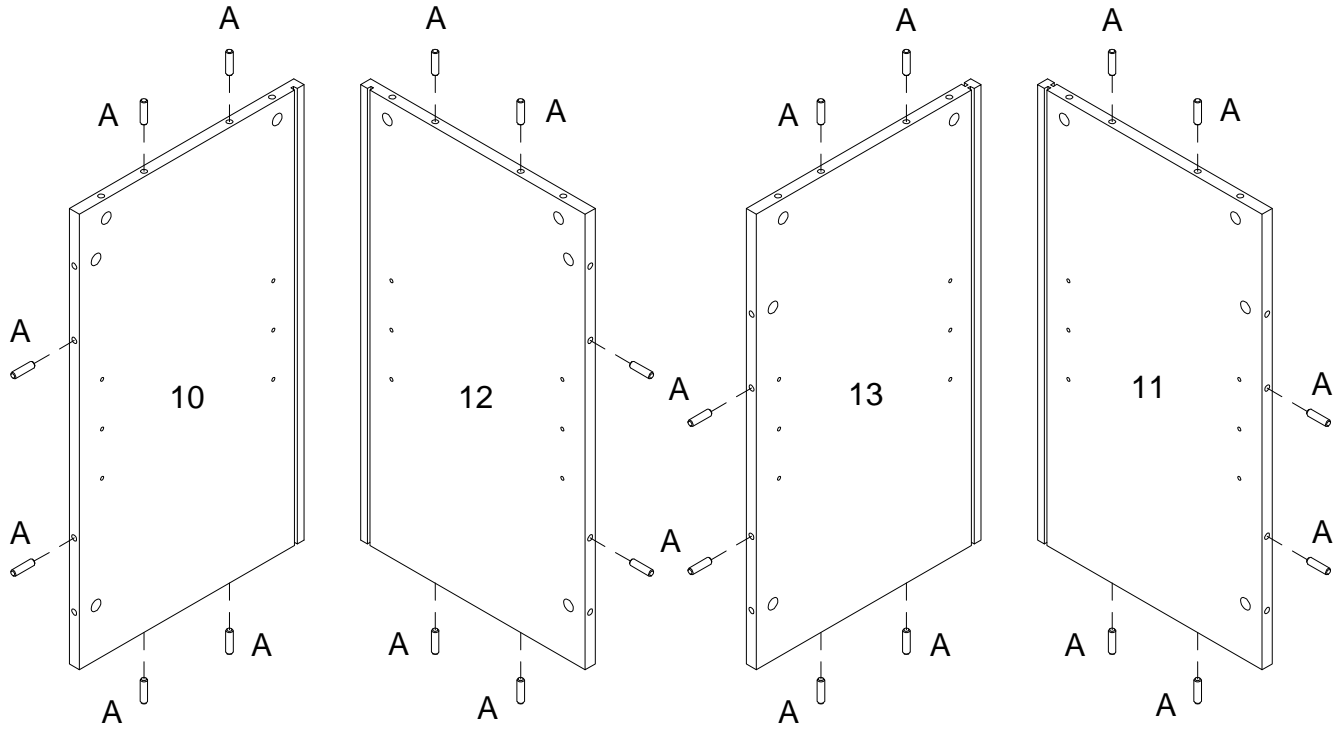

Insert wooden dowel (A) into parts (10,11,12,13) as per diagram.

Step 4

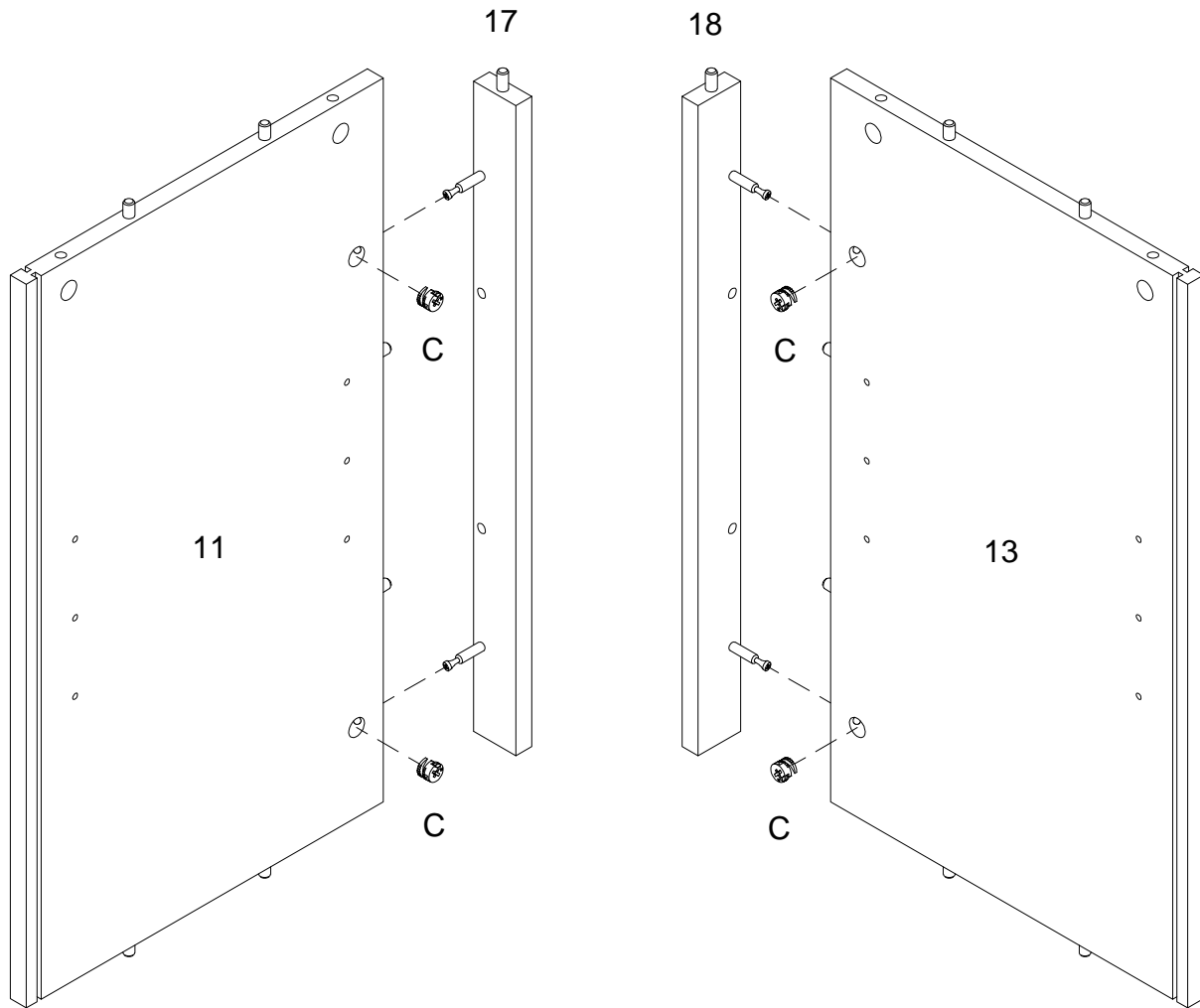
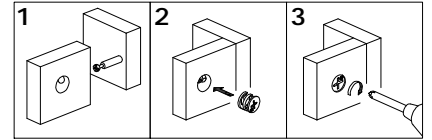

Using cam lock(C) secure part (17) to part (11) ,part (18) to part (13) with Philips head screwdriver as per diagram.

Step 5

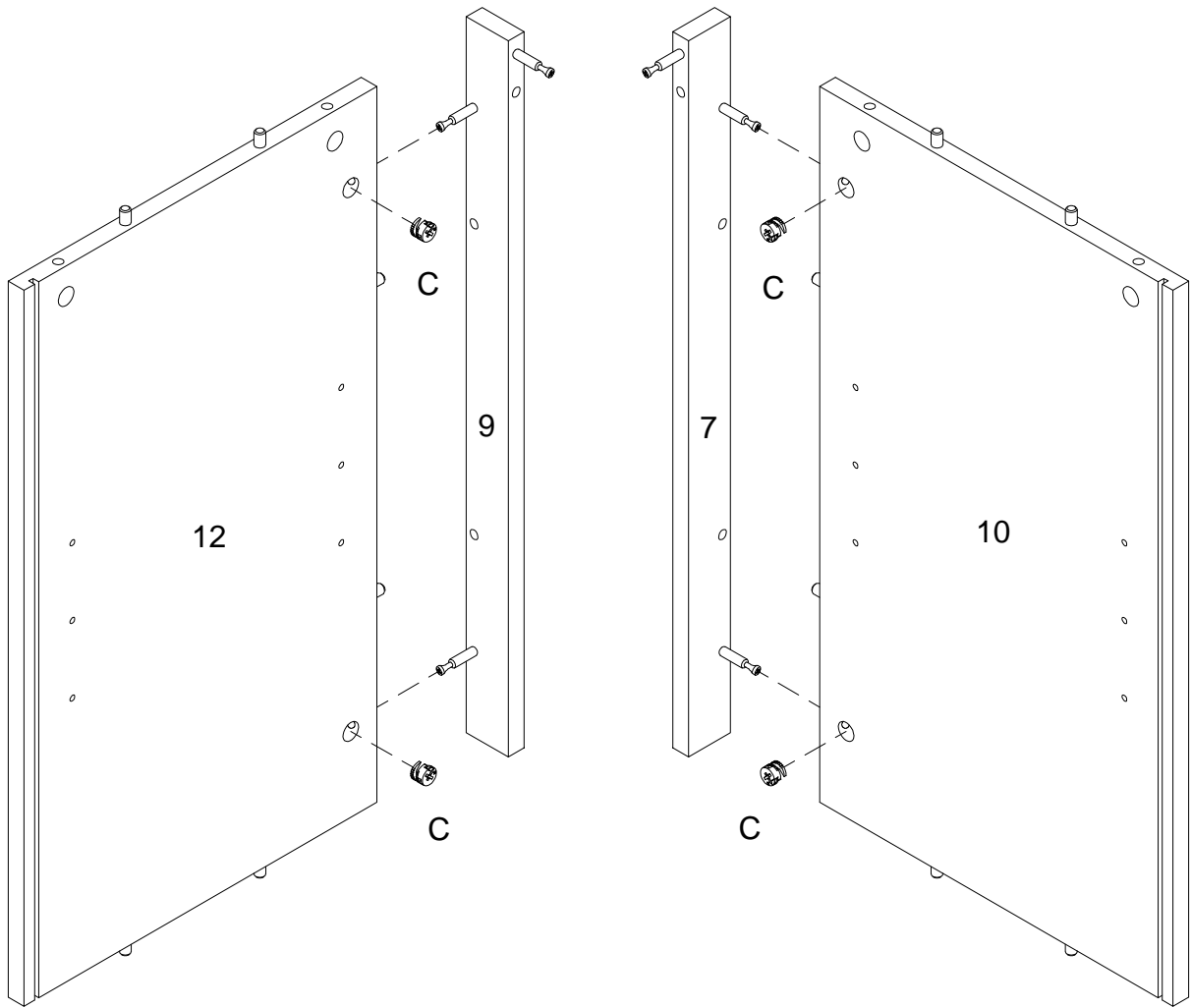
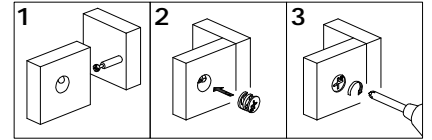

Using cam lock(C) secure part (9) to part (12) ,part (7) to part (10) with Philips head screwdriver as per diagram.

Step 6

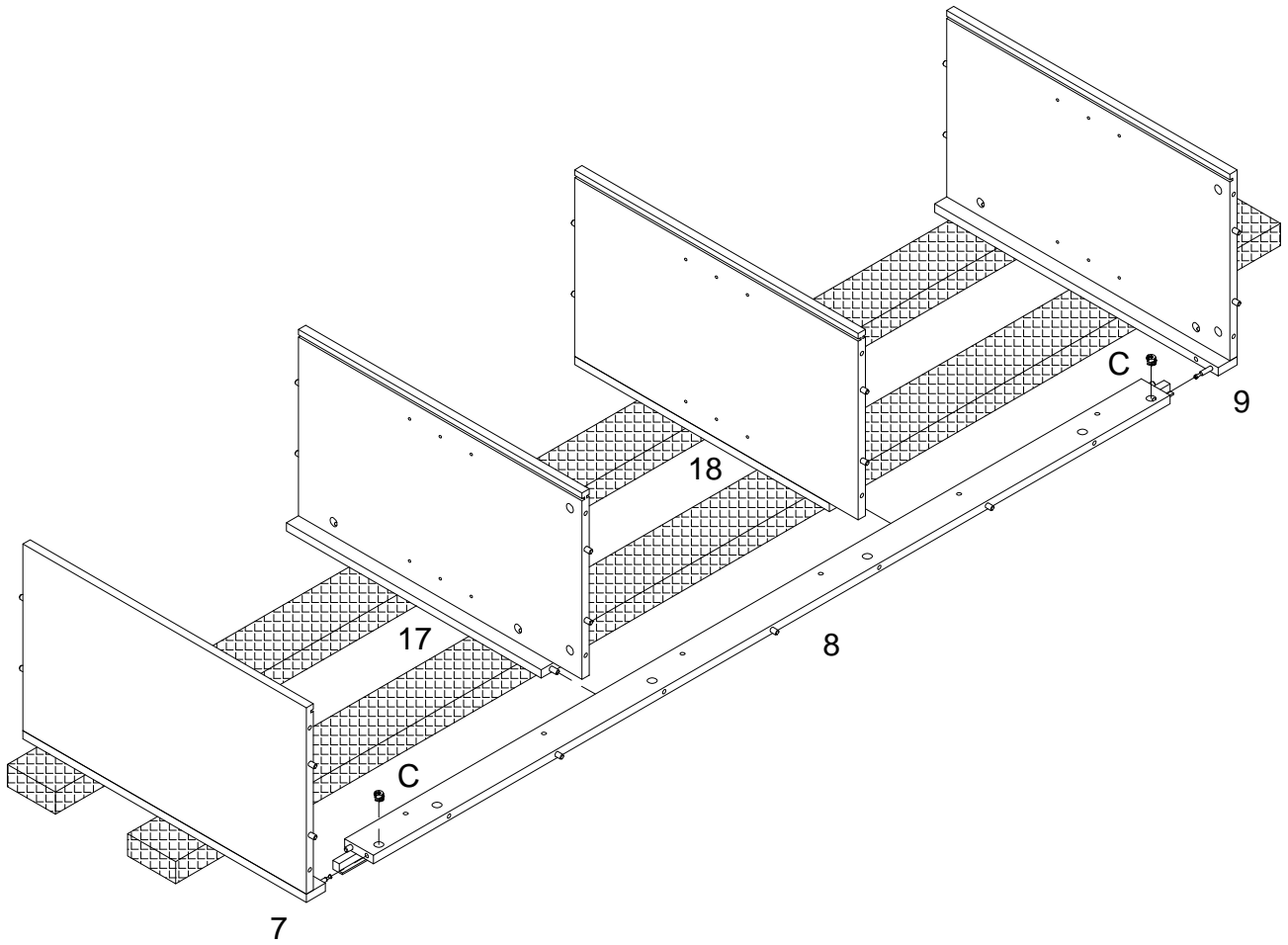
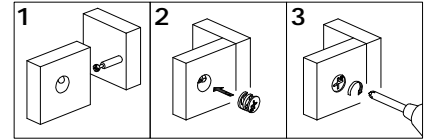

Place part (8) to parts (17,18) and use cam lock(C) secure parts (7,9) to part (8) with Philips head screwdriver as per diagram.

Step 7

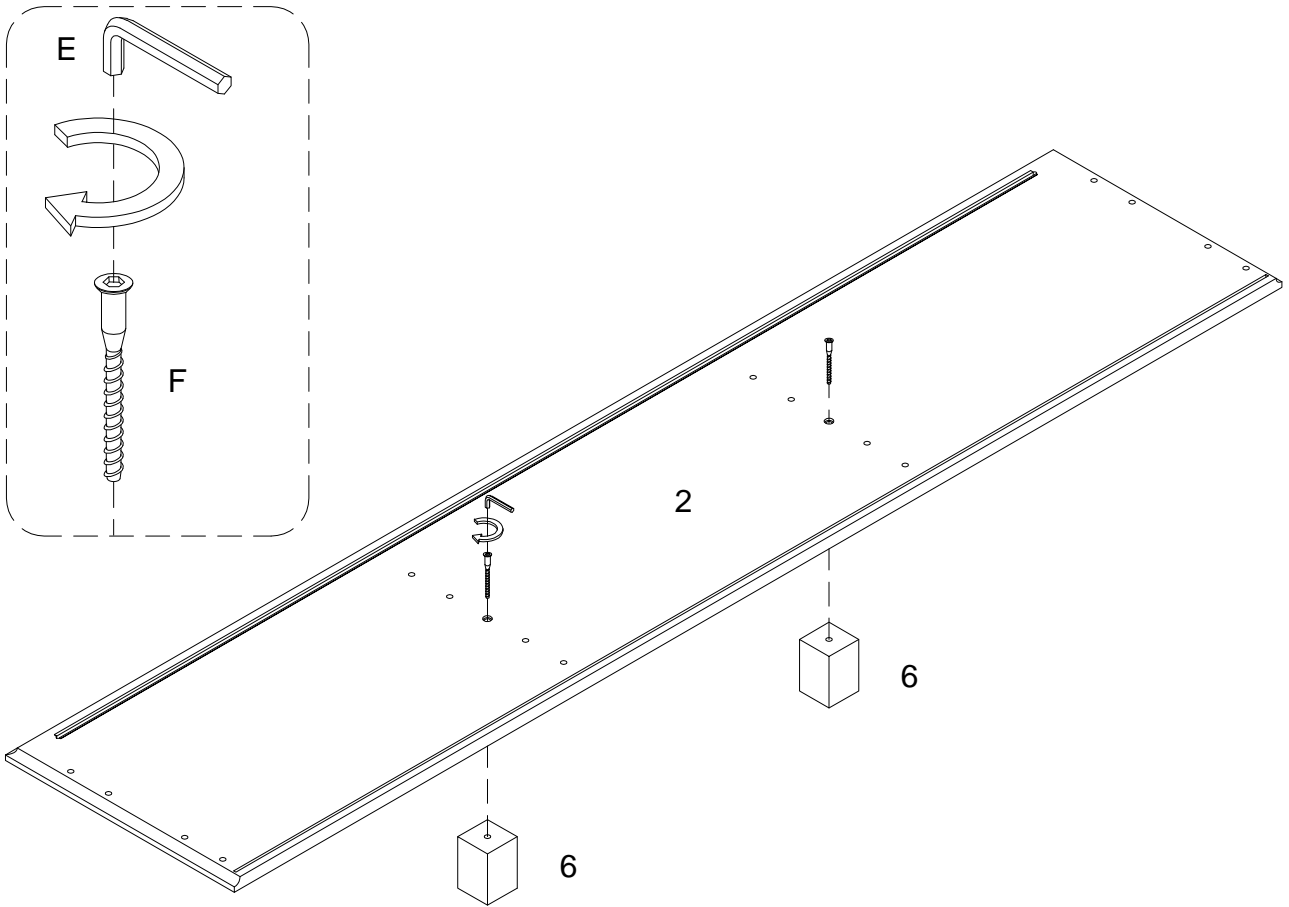

Using screw (F) attach part (2) into part (6) with hex key (E) as per diagram.

Step 8

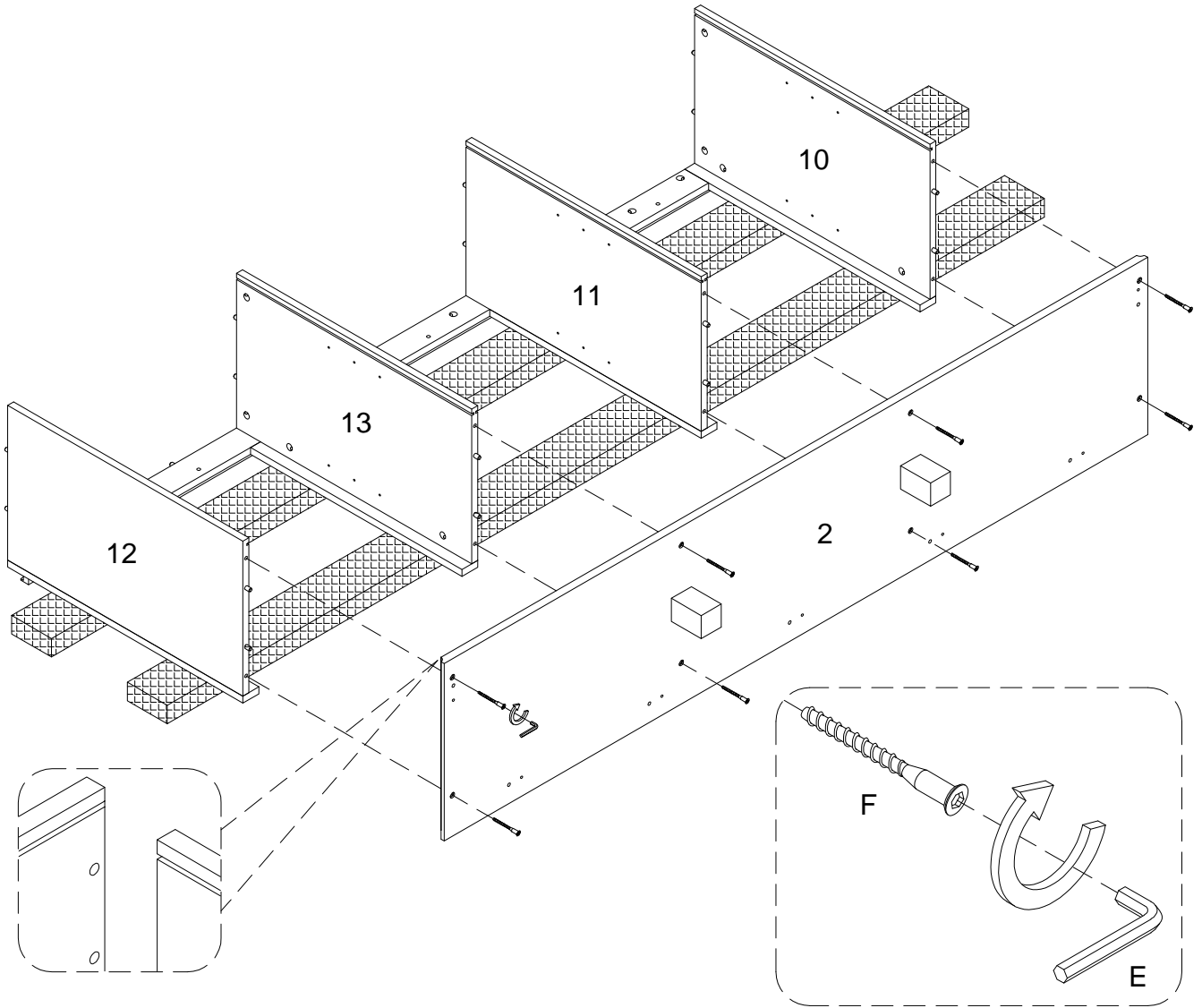

Using screw (F) attach part (2) into parts (10,11,12,13) with hex key (E) as per diagram.

Step 9

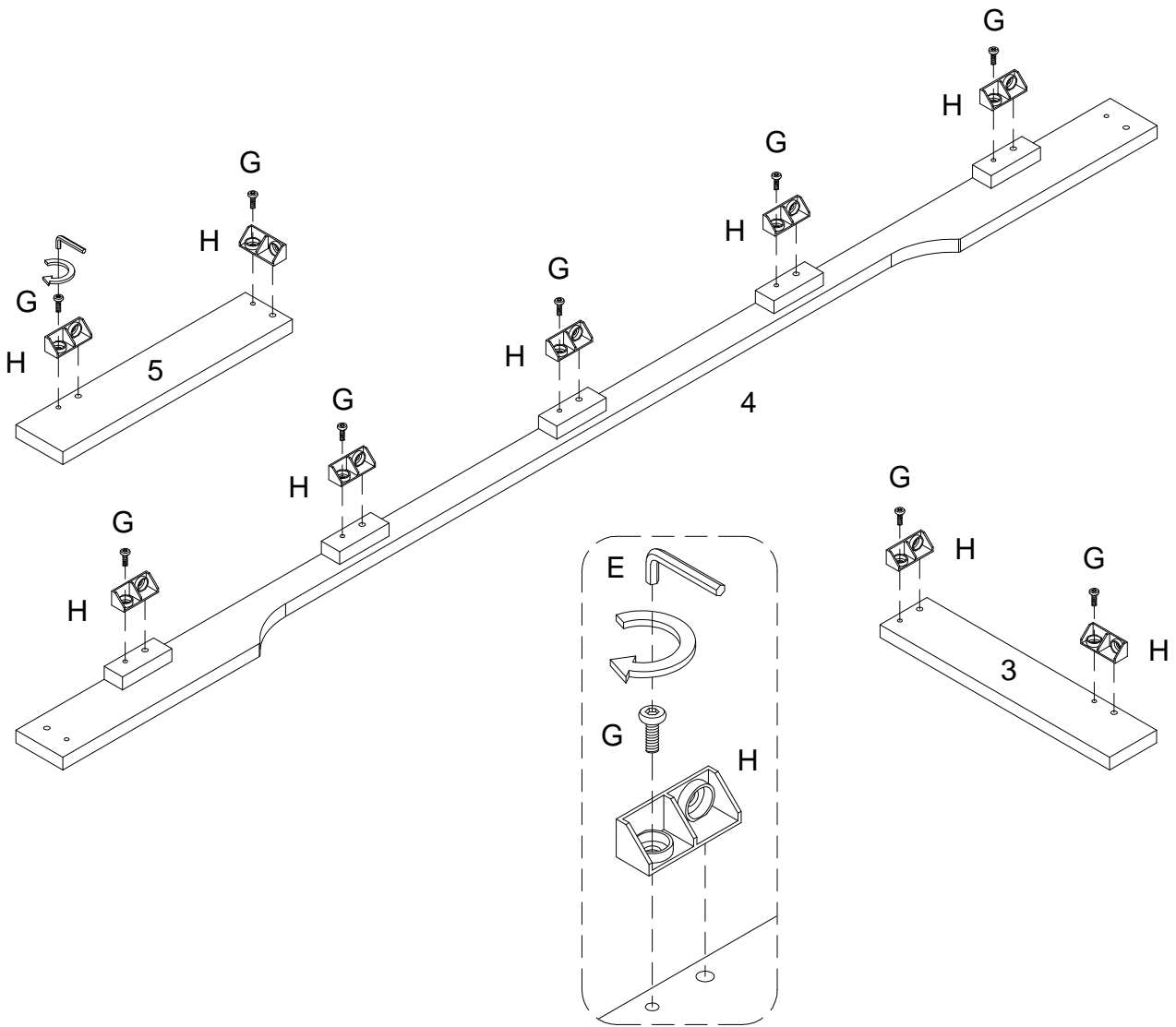

Using bolt (G) secure plastic wedge (H) to parts (3,4,5) with Hex key (E) as per diagram.

Step 10

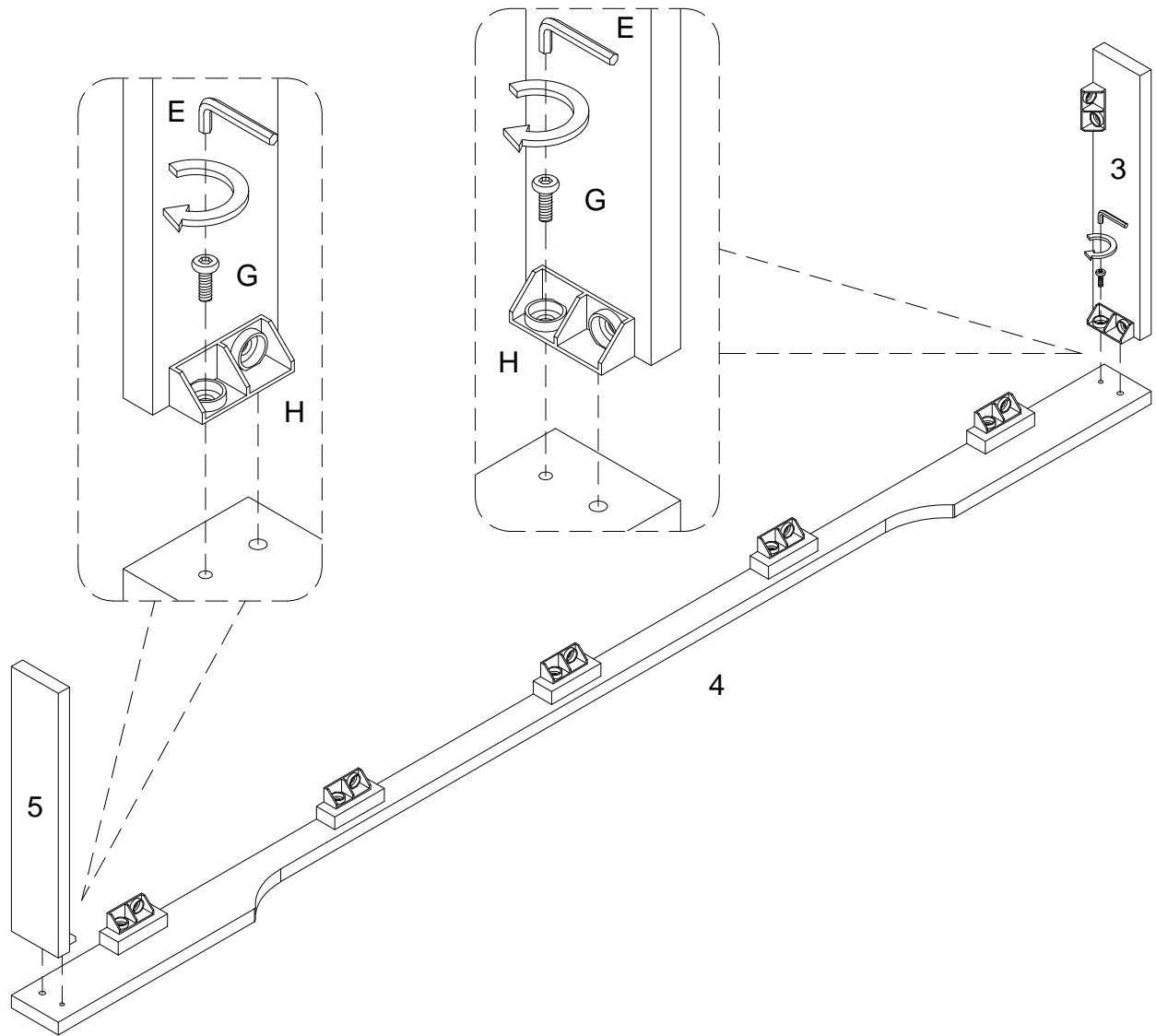

Using bolt (G) secure plastic wedge (H) in parts (3,5) to part (4) with Hex key (E) as per diagram.

Step 11

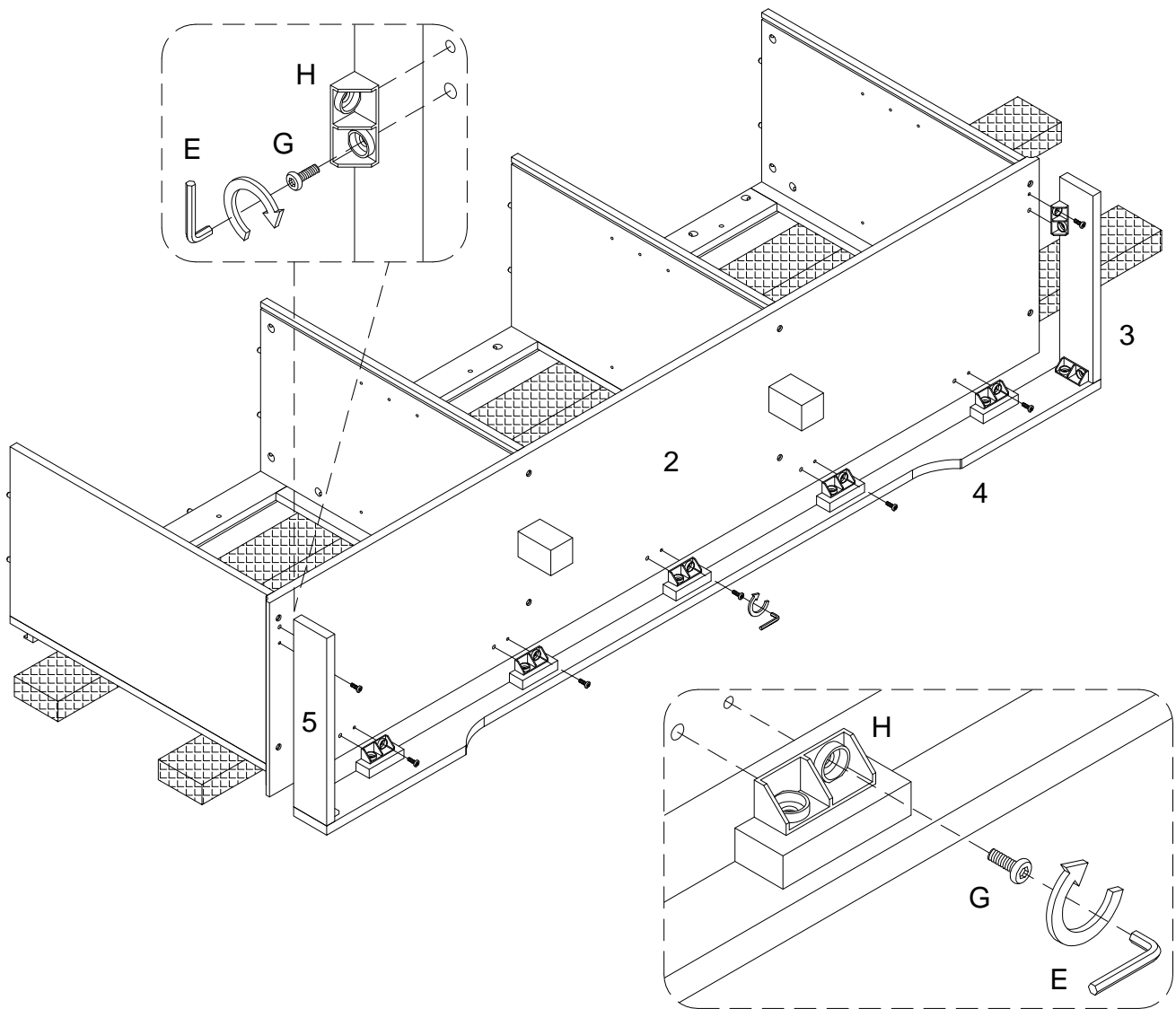

Using bolt (G) secure plastic wedge (H) in parts (3,4,5) to part (2) with Hex key (E) as per diagram.

Step 12

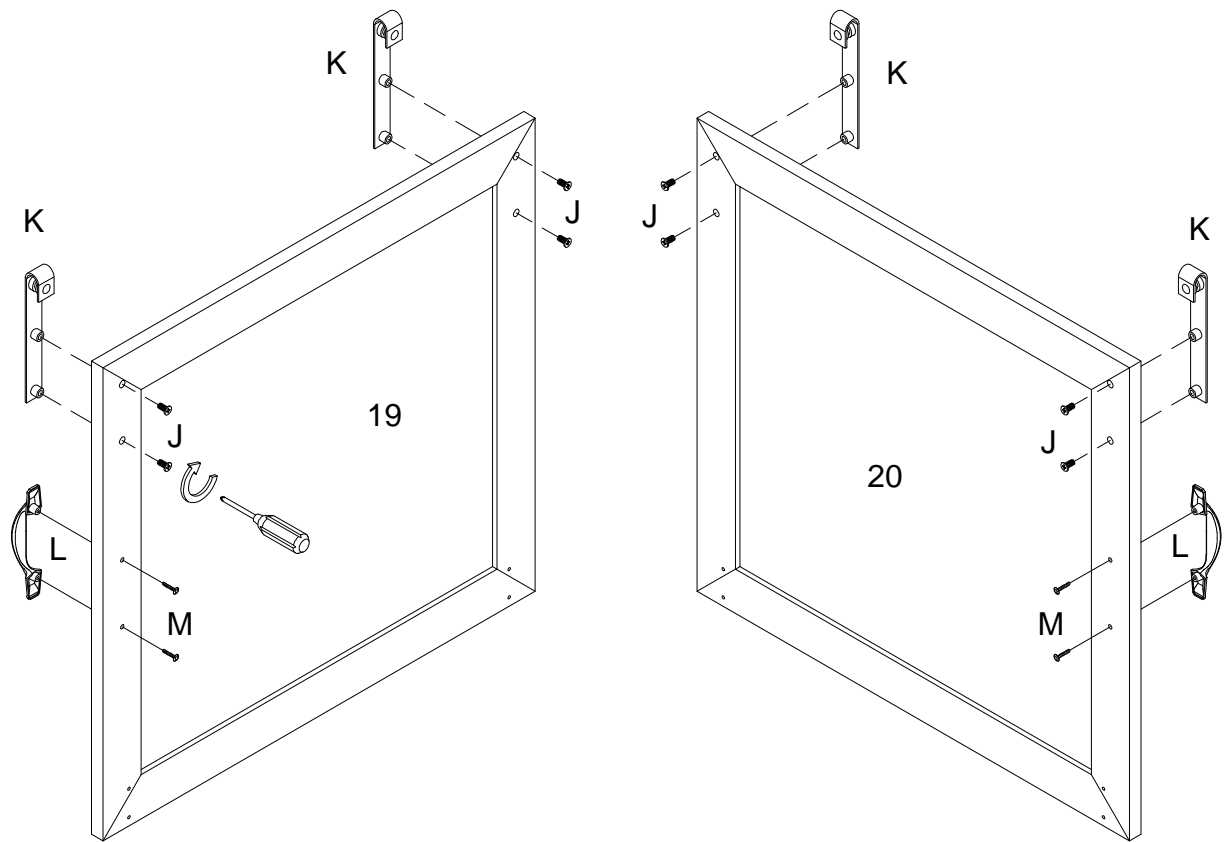

Using handle bolt (M) secure parts (19,20) to handle (L) ,then using bolt (J) attach parts (19,20) to Pulley (K) with Philips head screwdriver as per diagram.

Step 13

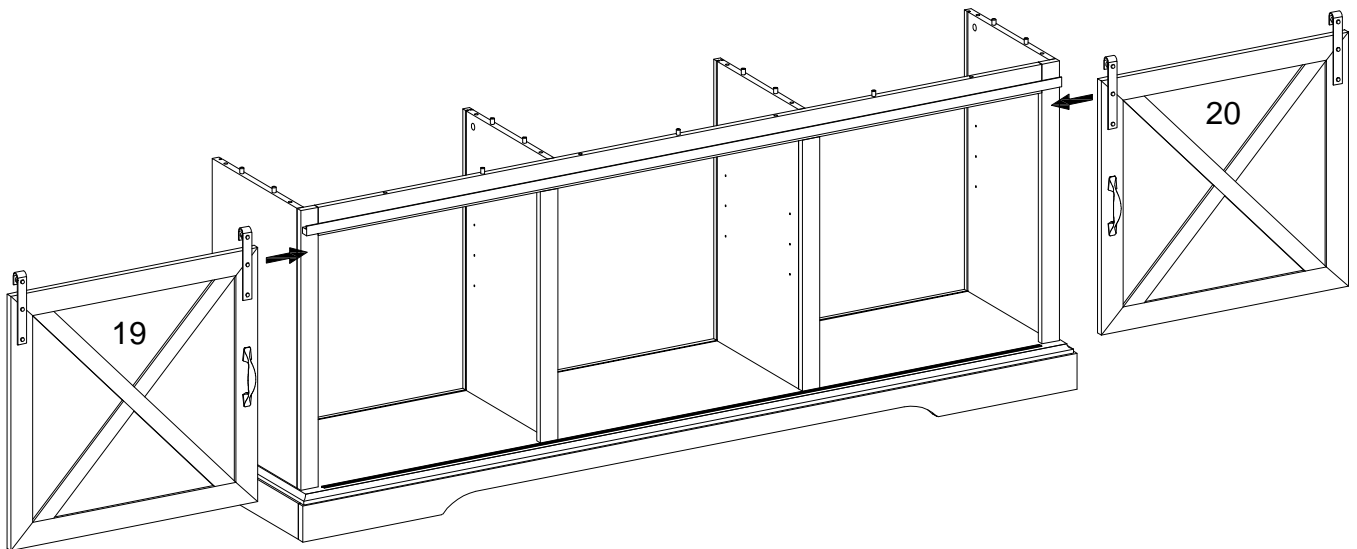
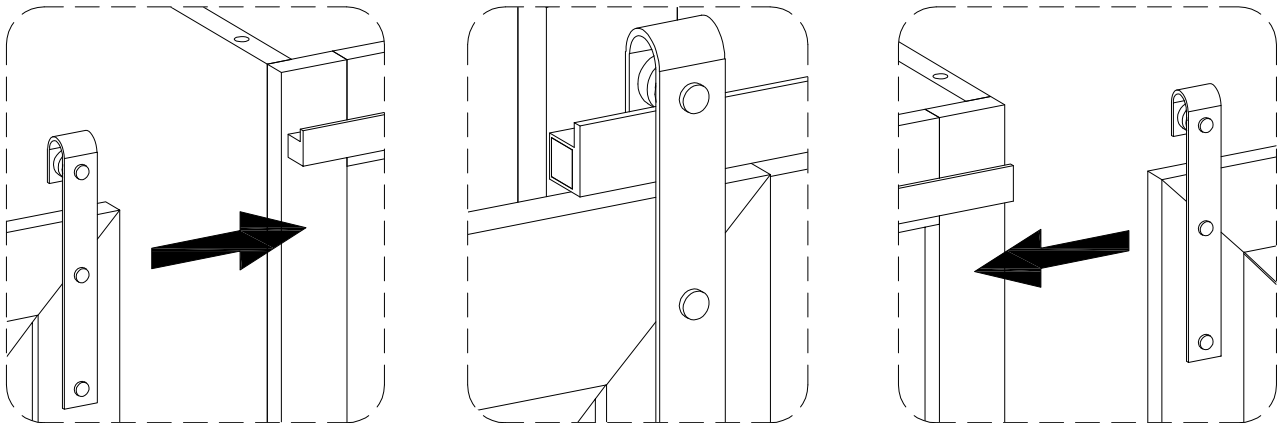

Pick up the doors (19,20), and fit the pulley over the slider rails on the unit as per diagram.

Step 14

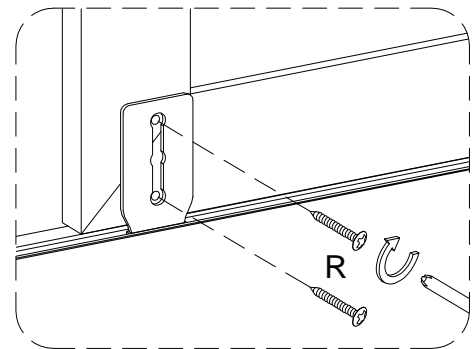
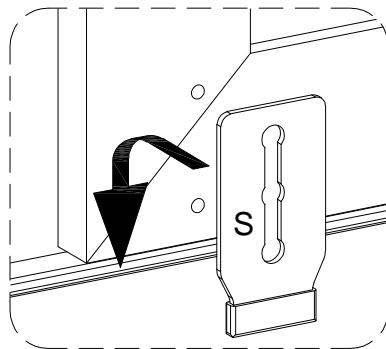
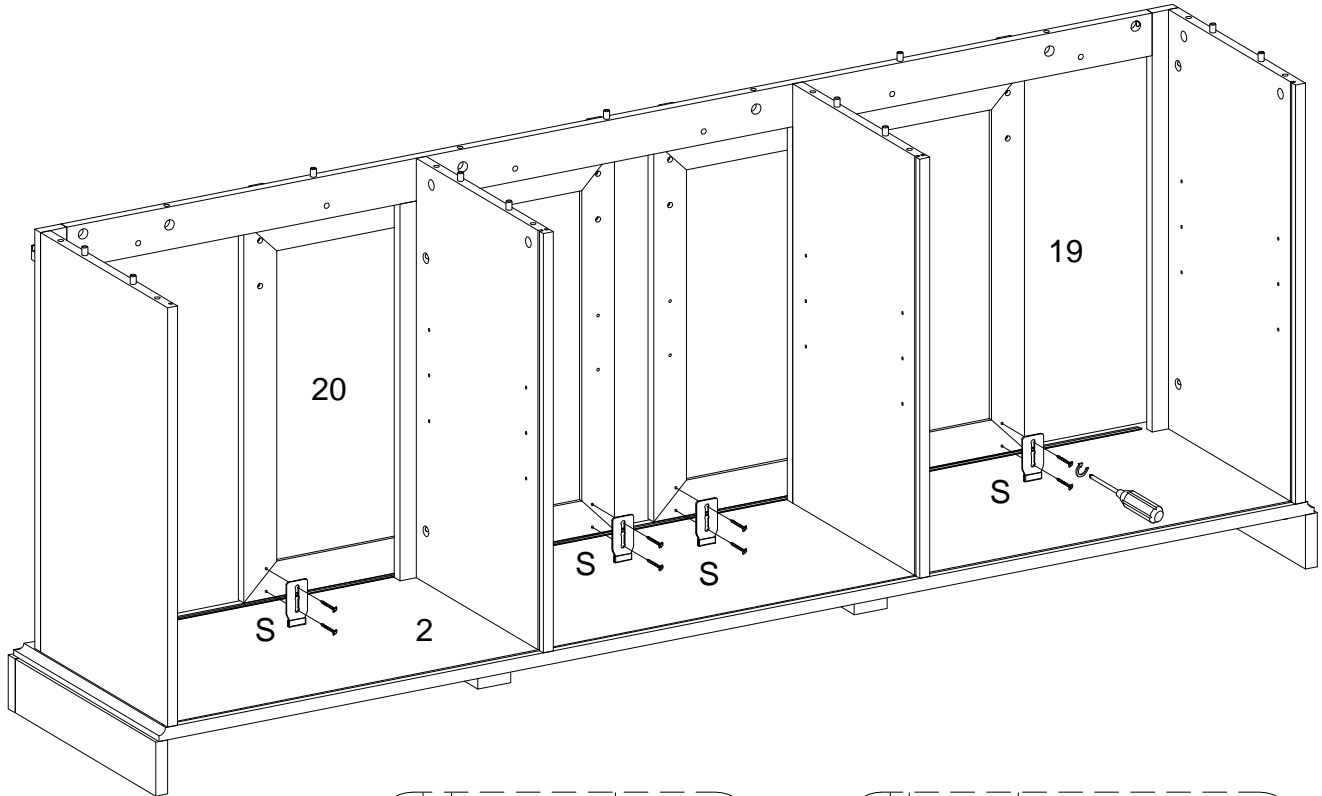

Using screw (R) attach plate (S) to parts (19,20) with Philips head screwdriver as per diagram.

Step 15

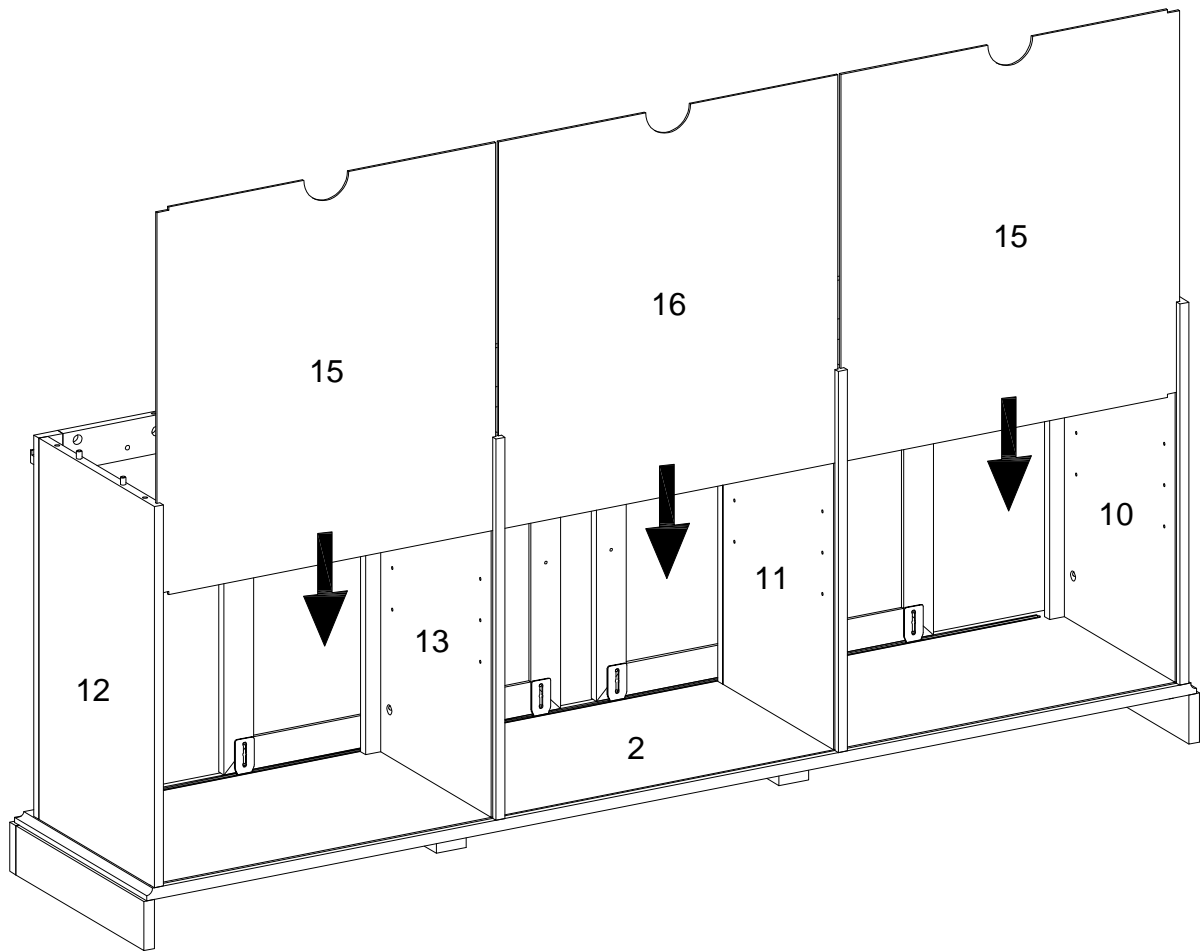

Put parts (15,16) as per diagram.

Step 16

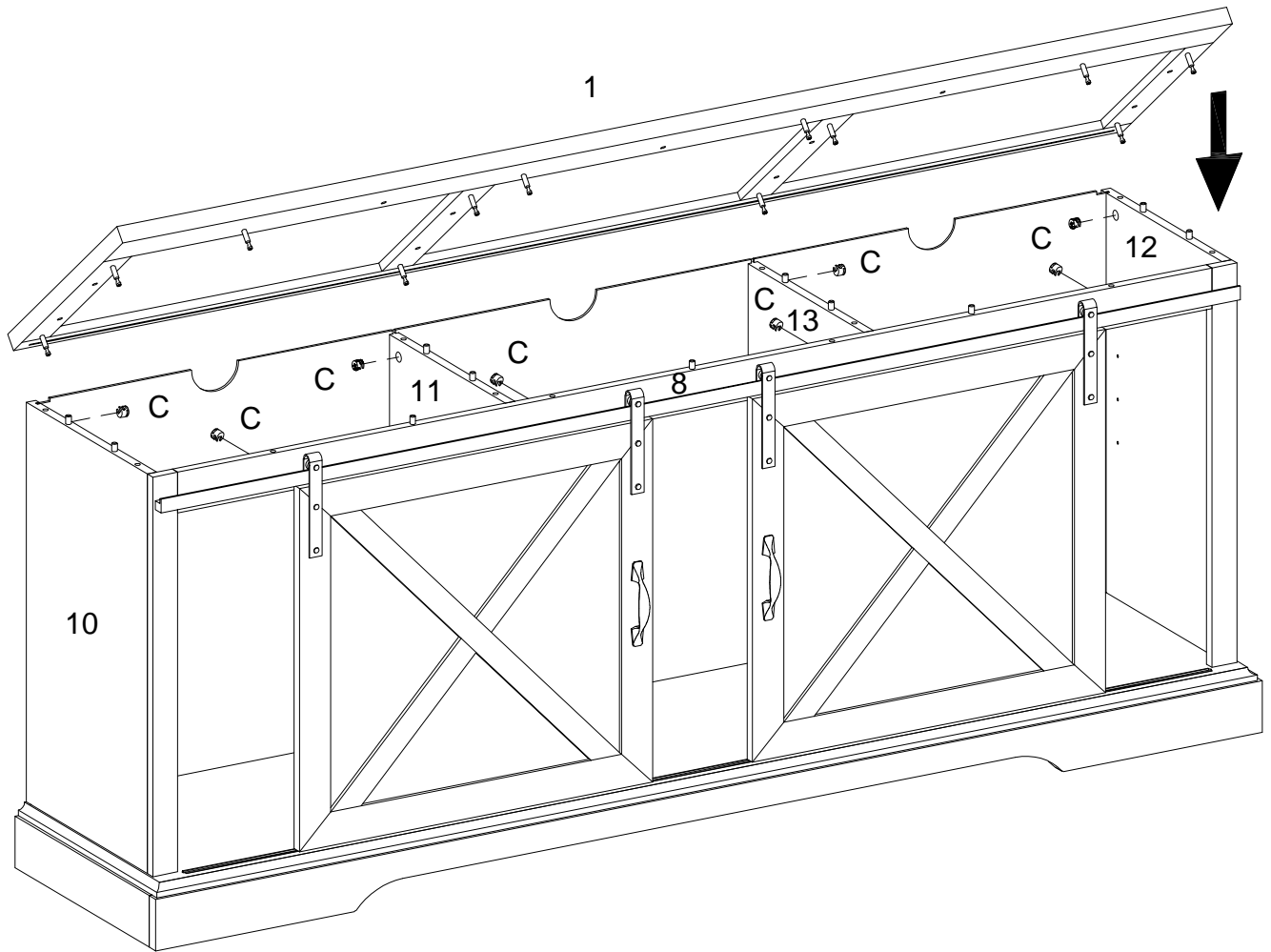
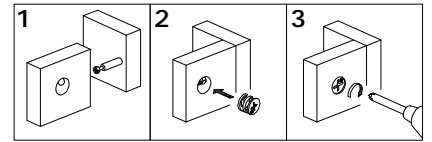

Using cam lock (C) secure part (1) into parts (8,10,11,12,13) with Philips head screwdriver as per diagram.

Step 17

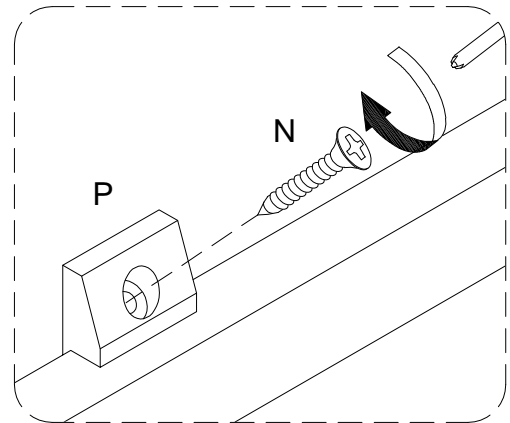
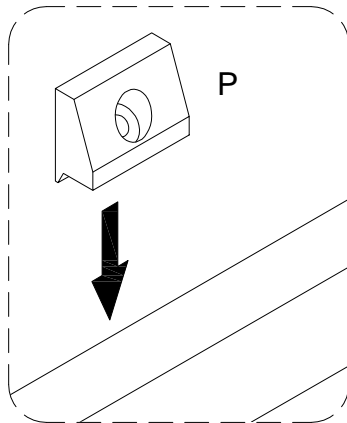
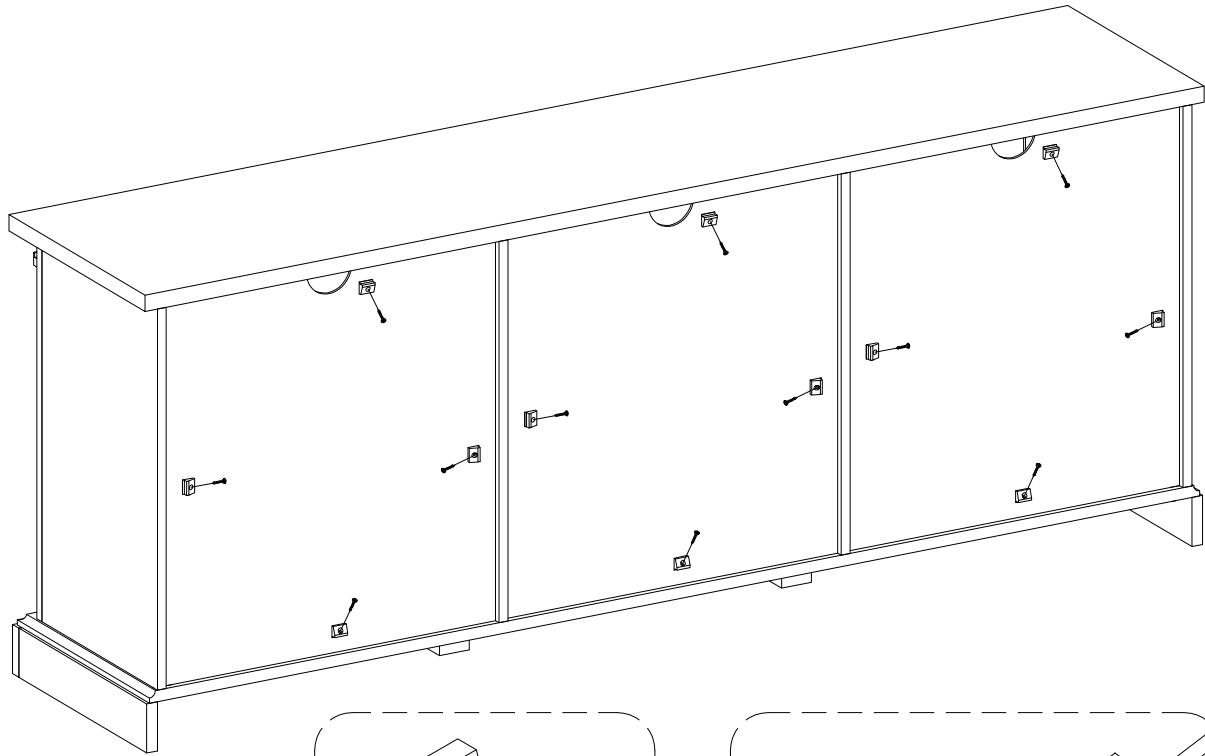

Using screw (N) secure plastic wedge (P) with Philips head screwdriver as per diagram.

Step 18

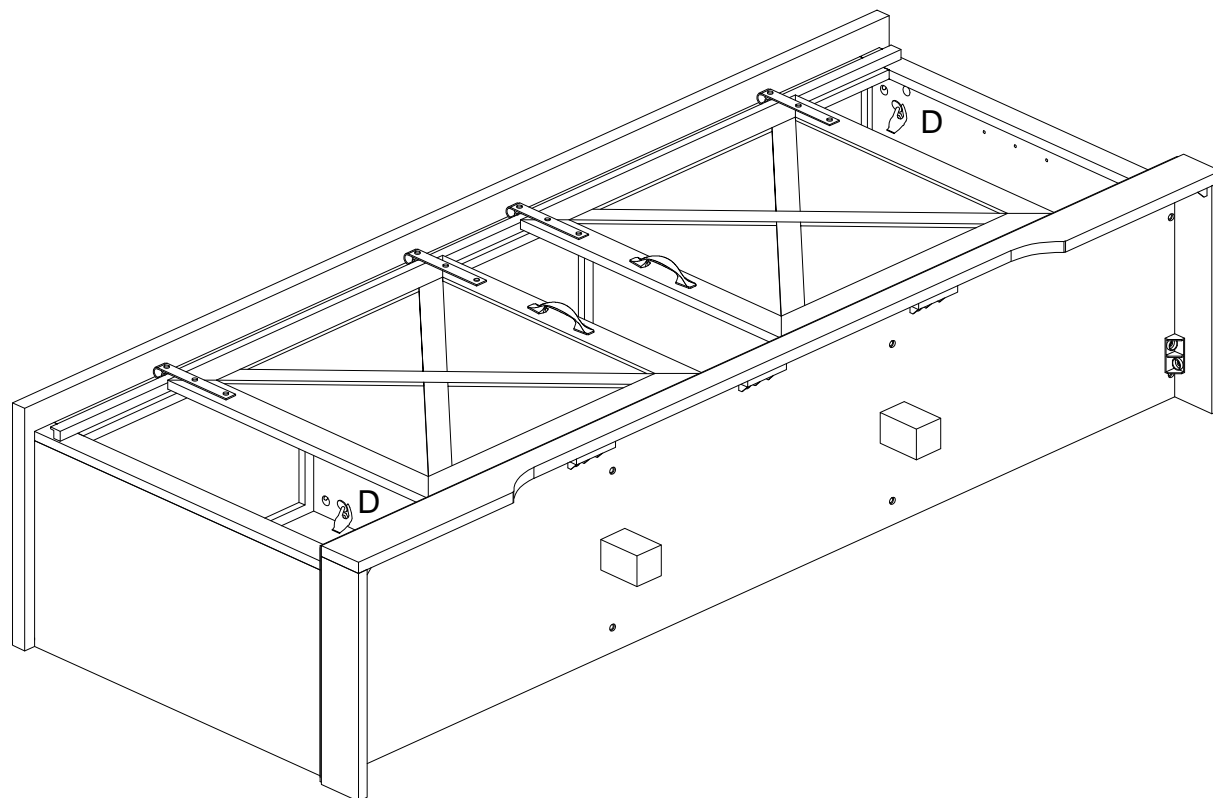

Place sticker (D) cover the holes as per diagram .

Step 19

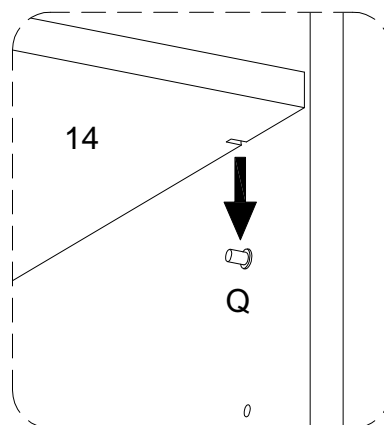
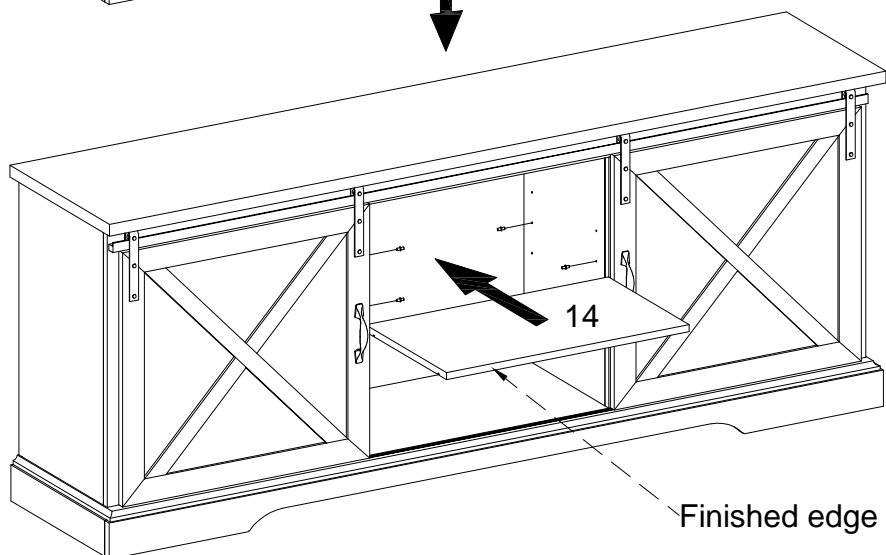
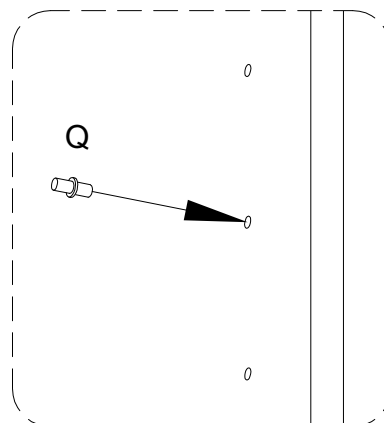
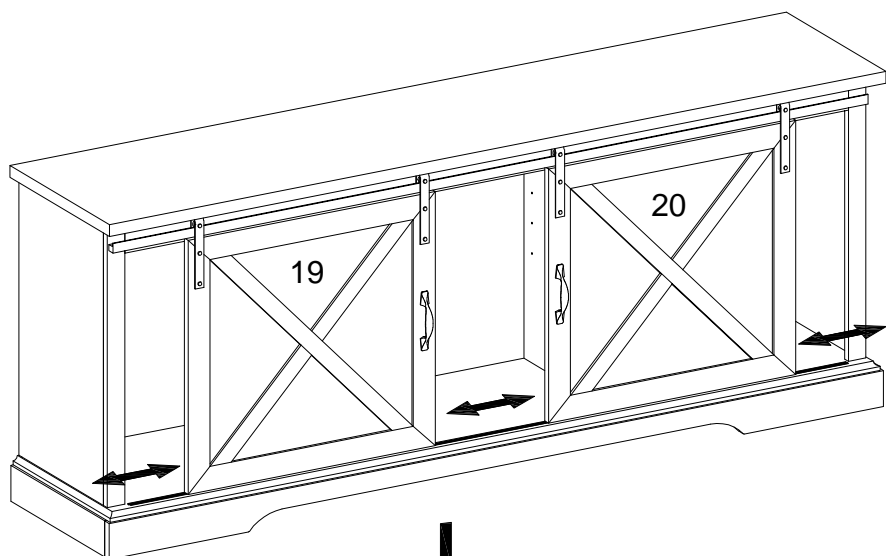

Insert shelf support pin (Q) into unit as per diagram. Make sure you place the four shelf support pins (Q) in the same level. So the shelf is not titled. Put part (14) into unit as per diagram. Tilt and rest the adjustable shelf(14) onto the shelf support pins .

Step 20

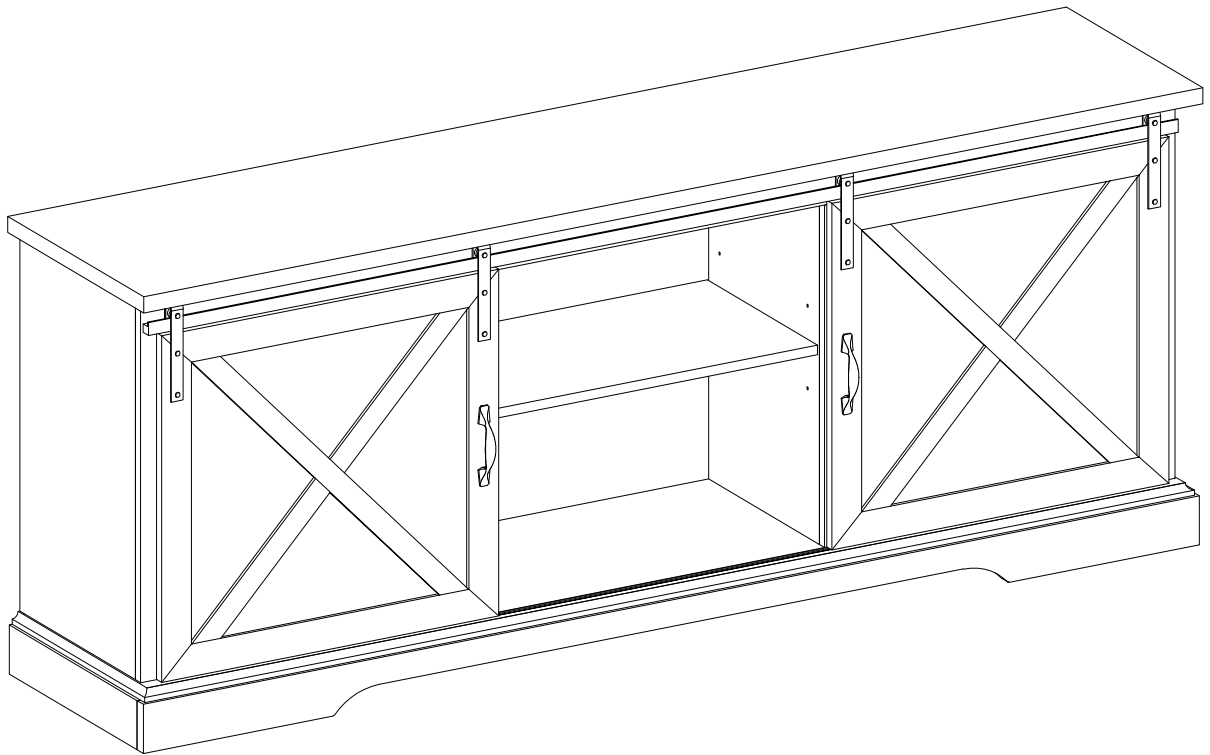

Final Assembly